

# REMOVAL PROCEDURE



SERVICE  
MANUAL

S E R V I C E M A N U A L

## 3 HP Class

-  Outdoor Unit
-  Inverter
-  Pair Type



# **Service Manual Removal Procedure**

## **Outdoor Unit**

### **Applicable Models**

- Heat Pump  
RZQ71KAVLT

# Table of Contents

1. Procedure to Remove Outside Panels and Related Parts .....	2
2. Procedure to Remove Propeller Fan and Fan Motor .....	3
3. Procedure to Remove Switch Box .....	4
4. Procedure to Remove PCB Assy (1).....	5
5. Procedure to Remove Assy (2) .....	6
6. Procedure to Remove Assy (3) .....	7
7. Procedure to Remove Low Pressure Thermistor, Electronic Expansion Valve, and Others.....	8
8. Procedure to Remove Thermistor .....	9
9. Procedure to Remove Four Way Valve.....	10
10. Procedure to Remove Compressor.....	11

# 1. Procedure to Remove Outside Panels and Related Parts

**Procedure**



**Warning**

Be sure to wait for 10 minutes or more after turning off all power supplies before disassembling work.

Step	Procedure	Points
1	Remove the front panel 2 (the front panel of the side panel), after removing the 1 screw and pushing the front panel downward.	
2	Remove the top panel, after removing the 8 screws.	
3	Remove the front panel 1, after removing the 7 screws.	
4	Remove the right side panel, after removing the 5 screws.	
5	Remove the front panel of the piping cover, after removing the 1 screw.	
6	Remove the side panel of the piping cover, after removing the 4 screws.	
7	Hold the lower part (2 positions) and pull frontward. Remove from the top hooks using a flathead screwdriver etc. and then pull downward the whole suction grille to remove it.	

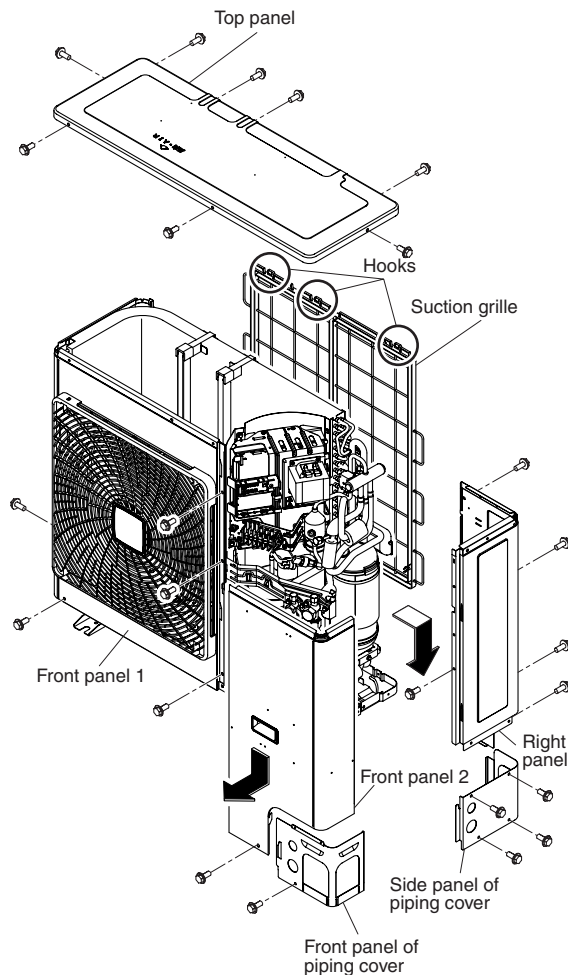

# 2. Procedure to Remove Propeller Fan and Fan Motor

**Procedure**



**Warning**

Be sure to wait for 10 minutes or more after turning off all power supplies before disassembling work.

Step	Procedure	Points
<p>■ Remove the front panel 2, following the procedure indicated at "Removal of Outside Panels and Related Parts".</p>		
<p>1. Remove the propeller fan</p> <p>1 Remove the 4 screws that fix the discharge grille. Remove from 4 hooks at upper and lower side and then remove the discharge grille.</p> <p>2 Remove the fan setting nut that fixes the propeller fan.</p> <p>3 * Remove the top panel, following the procedure indicated at "Removal of Outside Panels and Related Parts".</p>		
<p>2. Remove the fan motor</p> <p>1 Remove the connector for the fan motor from the printed wiring board (PWB). (Refer to *1)</p> <p>2 Remove the 3 clamps which fix the lead wire. (3 hooks of partition plate)</p> <p>3 Remove the 3 screws of the front panel and then pull lead wire frontward.</p> <p>4 Pull out the fan motor, after removing the 4 fixing bolts.</p>		<p>■ In case of removing the connector, do not pull the lead wire. Hold the connector part and press the hook.</p> <p>■ Precaution for the motor installation: Be sure to fix the lead wire of the motor. Otherwise the lead wire might be entangled with the motor and causes failure.</p>

### 3. Procedure to Remove Switch Box

**Procedure**



**Warning**

Be sure to wait for 10 minutes or more after turning off all power supplies before disassembling work.

Step	Procedure	Points
<p>■ Remove the front panel, the suction grille, the top panel, the side panel, and the piping cover, following the procedure indicated at "Removal of Outside Panels and Related Parts".</p>		<p>■ Precaution for the installation of the switch box: After restoring each part, fix each lead wire with the clamps in the same way as originally fixed.</p>
<p>1 Remove the wirings to the switch box and the related parts</p> <p>■ Remove the connectors below;</p> <ul style="list-style-type: none"> <li>• Fan motor (X106A)</li> <li>• Pressure thermistor (X17A)</li> <li>• Coil of four way valve (X25A)</li> <li>• Compressor relay (X502A)</li> </ul> <p>■ Remove the parts below;</p> <ul style="list-style-type: none"> <li>• Coil of motor operated valve (Y1E)</li> <li>• Liquid pipe thermistor (R6T)</li> <li>• Suction pipe thermistor (R3T)</li> <li>• Discharge pipe thermistor (R2T)</li> <li>• Outdoor air thermistor (R1T)</li> <li>• Heat exchange thermistor (R4T)</li> <li>• Thermistor at the midpoint of heat exchange (R5T)</li> </ul> <p>* When removing, cut the clamps that fix each lead wire of each part.</p>		
<p>2 Removing the switch box</p> <p>■ Remove 2 screws that fix the switch box.</p> <p>■ Holding the switch box, lift upward and remove the 2 hooks (1 right and 1 left) and then pull out.</p>		

# 4. Procedure to Remove PCB Assy (1)

**Procedure**



**Warning**

Be sure to wait for 10 minutes or more after turning off all power supplies before disassembling work.

Step	Procedure	Points
<ul style="list-style-type: none"> <li>■ Remove the top panel, the front panel 2, the side panel, and the piping cover, following the procedure indicated at "Removing Outside Panels and Related Parts".</li> <li>■ Remove the switch box, following the procedure indicated at "Removing switch box".</li> </ul>		
<p>1. Remove the PCB for the display (A2P)</p>		<ul style="list-style-type: none"> <li>■ Installation section of the PCB for the display (A2P)</li> </ul>
<p>1</p> <ul style="list-style-type: none"> <li>■ Remove the connectors (X205A) on the PCB for the display.</li> <li>■ Since the PCB for the display (A2P) is fixed with 2 hooks, take from them and then remove the PCB for the display.</li> </ul>	<p>PCB for the display (Retrieved)</p>	

# 5. Procedure to Remove Assy (2)

**Procedure**  **Warning** Be sure to wait for 10 minutes or more after turning off all power supplies before disassembling work.

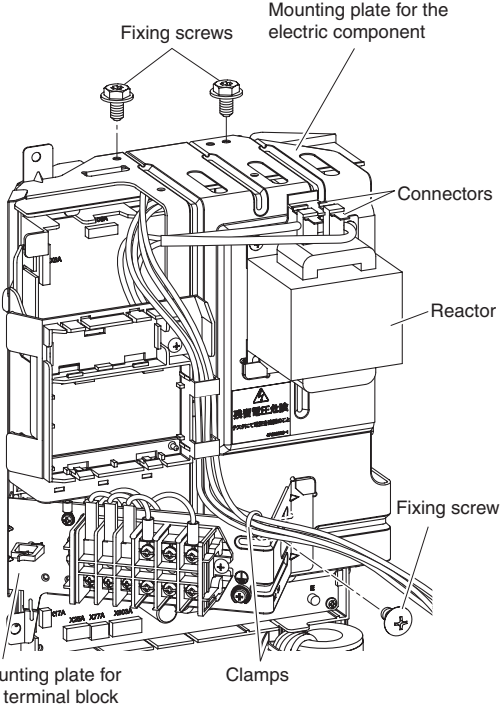
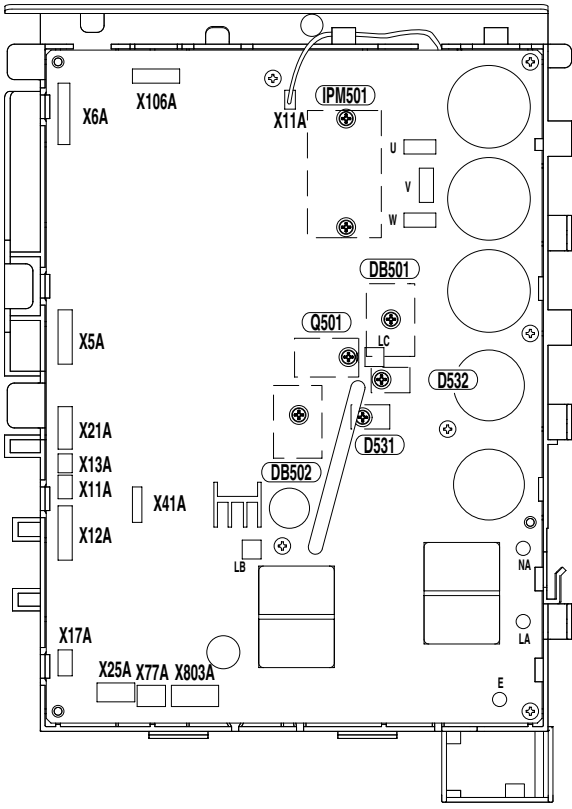
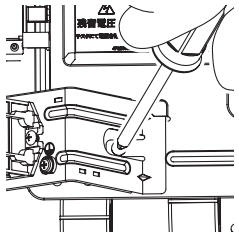
Step	Procedure	Points
2.	Remove the mounting plate for the electric component	
1	Remove the mounting plate for the terminal block, after removing the 1 screw.	
2	Remove the 2 connectors on the reactor.	
3	Cut 3 clamps that fix the wiring.	
4	Remove the mounting plate for the electric component after removing the 2 screws.	
		
<p>After removing the mounted electric component</p>		
		



# 6. Procedure to Remove Assy (3)

**Procedure**  **Warning** Be sure to wait for 10 minutes or more after turning off all power supplies before disassembling work.

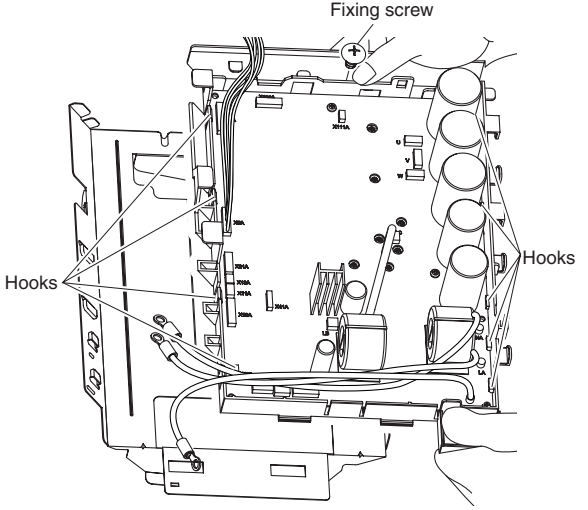
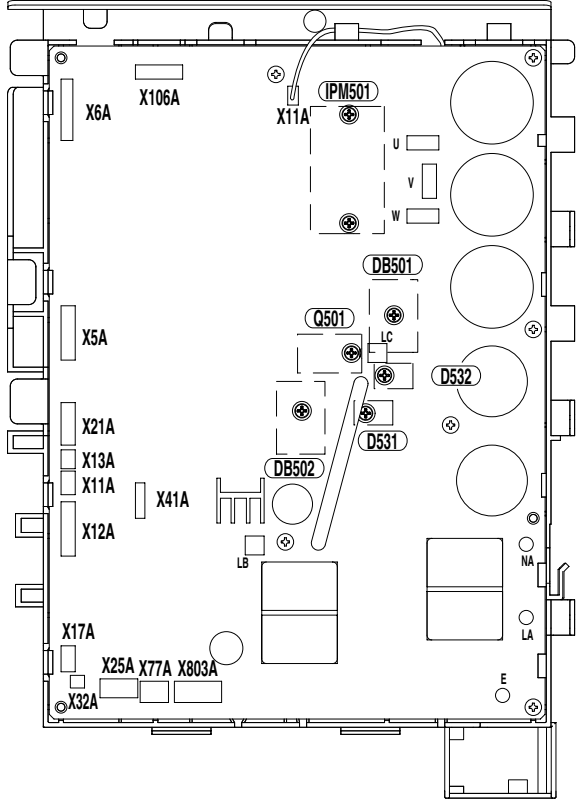
Step	Procedure	Points
3. Remove the assembly of the PCB (AIP)		
1 Remove the connectors on the PCB.		
2 Remove the 1 screw that fixes the electric component to the mounting plate.		
3 Pull out the assembly of the PCB, after removing from the hooks at the both sides (9 locations).	<p data-bbox="491 952 858 981">Assembly of the PCB (Retrieved)</p> 	

# 7. Procedure to Remove Low Pressure Thermistor, Electronic Expansion Valve, and Others

**Procedure**



**Warning**

Be sure to wait for 10 minutes or more after turning off all power supplies before disassembling work.

Step	Procedure	Points	
<ul style="list-style-type: none"> <li>■ Remove the outside panels, their parts, and the switch box, following the procedure indicated at "Removal of Outside Panels and Related Parts" and other instructions.</li> </ul>			
<ul style="list-style-type: none"> <li>1. Remove the pressure thermistor</li> </ul>			
<ul style="list-style-type: none"> <li>1 Remove the connector for the pressure thermistor (X17A).</li> <li>2 Remove the pressure thermistor after cutting off the brazing (1 location).</li> </ul>			<ul style="list-style-type: none"> <li>■ Be sure to collect the refrigerant first, before removing the main unit of the motor operated valve.</li> <li>■ Precaution for the mounting of the coil of the motor operated valve</li> </ul>
<ul style="list-style-type: none"> <li>2. Remove the pressure switch</li> </ul>			
<ul style="list-style-type: none"> <li>1 Remove the lead wire.</li> <li>2 Remove the pressure switch after cutting off the brazing.</li> </ul>			
<ul style="list-style-type: none"> <li>3. Remove the electronic expansion valve</li> </ul>			
<ul style="list-style-type: none"> <li>1 Pull out the coil from the electronic expansion valve upward.</li> <li>2 Cut the brazing (2 locations) and remove the body of the electronic expansion valve. (Replace with the assembly of the electronic expansion valve)</li> </ul>		<p>Press the coil into tube until the clip completely fits in the tube.</p>	

## 8. Procedure to Remove Thermistor

### Procedure



### Warning

Be sure to wait for 10 minutes or more after turning off all power supplies before disassembling work.

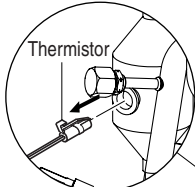
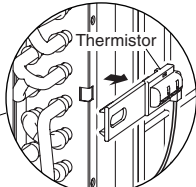
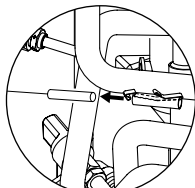
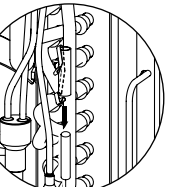
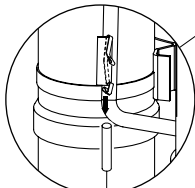
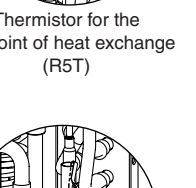
Step	Procedure	Points
<p>■ Remove the front panel 2, the right side panel, and the piping cover, following the procedure indicated at "Removal of Outside Panels and Related Parts".</p>	 <p>Thermistor</p>	 <p>Thermistor</p>
<p>1 Remove the outdoor air thermistor, pulling forward and then sliding it to the right.</p>	<p>Discharge pipe thermistor (R2T)</p>	<p>Outdoor air thermistor (R1T)</p>
<p>2 Pull out the discharge pipe thermistor (*1) by picking and pulling out the mounting spring.</p>	 <p>Suction pipe thermistor (R3T)</p>	 <p>Thermistor for the midpoint of heat exchange (R5T)</p>
<p>3 Pull out the suction pipe thermistor by pushing the fixing part.</p>	 <p>Liquid pipe thermistor (R6T)</p>	 <p>Heat exchange thermistor (R4T)</p>
<p>4 Since the thermistor of the heat exchange distribution pipe is fixed with the clamp plate, pull the clamp plate forward in order to remove the thermistor.</p>	<p>■ The discharge pipe thermistor, the suction pipe thermistor, the heat exchange distributor thermistor, and the thermistor for the midpoint of the heat exchange are connected to the 1 common connector. When replacing, you have to replace all 4 thermistors at once.</p>	
<p>5 Remove the thermistor at the midpoint of heat exchange by pushing the fixing part.</p>		
<p>6 Pull out the liquid pipe thermistor by pushing the fixing part.</p>		

# 9. Procedure to Remove Four Way Valve

**Procedure**



**Warning**

Be sure to wait for 10 minutes or more after turning off all power supplies before disassembling work.

Step	Procedure	Points
<ul style="list-style-type: none"> <li>■ Collect the refrigerant.</li> <li>■ Remove the outside panels, their parts, and switch box, following the procedure indicated at "Removing Outside Panels and Related Parts" and other instructions.</li> </ul>		<ul style="list-style-type: none"> <li>■ Be sure to confirm that the refrigerant is completely collected before starting the work.</li> <li>■ Protect other pipings using a protective sheet for the welding or steel plate so that the flame for the gas welding may not damage them.</li> <li>■ When brazing, cool down the main unit using a wet waste etc. so that the temperature of the main unit may not get higher than 120 °C.</li> </ul>
<p>1 Remove the four way valve after removing the 1 screw.</p> <p>2 Remove the main unit of the four way valve after cutting off the brazing (4 locations).</p>		

# 10.Procedure to Remove Compressor

**Procedure**



**Warning** Be sure to wait for 10 minutes or more after turning off all power supplies before disassembling work.

Step	Procedure	Points
<ul style="list-style-type: none"> <li>■ Collect the refrigerant.</li> <li>■ Remove the outside panels, their parts, and the switch box, following the procedure indicated at "Removing Outside Panels and Related Parts" and other instructions.</li> </ul>		<ul style="list-style-type: none"> <li>■ Be sure to confirm that the refrigerant is completely collected before starting the work.</li> </ul>
<p>1 Remove the fixing plate for the stop valve after removing the 5 screws.</p>		<ul style="list-style-type: none"> <li>■ The color of each terminal</li> </ul> <p>U: Red V: White W: Blue</p>
<p>2 Remove the sound insulation (1).</p>		<ul style="list-style-type: none"> <li>■ One of the fixing nuts of the compressor is located at the outer side of the partition plate.</li> </ul>
<p>3 Remove the terminal cover, after pushing the projective parts from the both sides.</p>		
<p>4 Remove the lead wire from the terminal (2).</p>		
<p>5 Pull out the sound insulation by unwinding the strings (2 locations).</p>		
<p>6 Remove the nuts that fix the compressor. (All the equipments are fixed with 3 nuts).</p>		
<p>7 Cut off the brazing (2 locations).</p>		
<p>8 Pull out the compressor by lifting upward.</p>		

# Revision History

Month / Year	Version	Revised contents
06 / 2013	Si281314E	First edition

Warning



- Daikin products are manufactured for export to numerous countries throughout the world. Prior to purchase, please confirm with your local authorised importer, distributor and/or retailer whether this product conforms to the applicable standards, and is suitable for use, in the region where the product will be used. This statement does not purport to exclude, restrict or modify the application of any local legislation.
- Ask a qualified installer or contractor to install this product. Do not try to install the product yourself. Improper installation can result in water or refrigerant leakage, electrical shock, fire or explosion.
- Use only those parts and accessories supplied or specified by Daikin. Ask a qualified installer or contractor to install those parts and accessories. Use of unauthorised parts and accessories or improper installation of parts and accessories can result in water or refrigerant leakage, electrical shock, fire or explosion.
- Read the User's Manual carefully before using this product. The User's Manual provides important safety instructions and warnings. Be sure to follow these instructions and warnings.

If you have any enquiries, please contact your local importer, distributor and/or retailer.

### Cautions on product corrosion

1. Air conditioners should not be installed in areas where corrosive gases, such as acid gas or alkaline gas, are produced.
2. If the outdoor unit is to be installed close to the sea shore, direct exposure to the sea breeze should be avoided. If you need to install the outdoor unit close to the sea shore, contact your local distributor.



JMI-0107

Organization:  
DAIKIN INDUSTRIES, LTD.  
AIR CONDITIONING MANUFACTURING DIVISION

Scope of Registration:  
THE DESIGN/DEVELOPMENT AND MANUFACTURE OF COMMERCIAL AIR CONDITIONING, HEATING, COOLING, REFRIGERATING EQUIPMENT, HEATING EQUIPMENT, RESIDENTIAL AIR CONDITIONING EQUIPMENT, HEAT RECLAIM VENTILATION, AIR CLEANING EQUIPMENT, COMPRESSORS AND VALVES.



JQA-1452

Organization:  
DAIKIN INDUSTRIES  
(THAILAND) LTD.

Scope of Registration:  
THE DESIGN/DEVELOPMENT AND MANUFACTURE OF AIR CONDITIONERS AND THE COMPONENTS INCLUDING COMPRESSORS USED FOR THEM



EC99J2044

All of the Daikin Group's business facilities and subsidiaries in Japan are certified under the ISO 14001 international standard for environment management.

### Dealer

### DAIKIN INDUSTRIES, LTD.

Head Office:  
Umeda Center Bldg., 2-4-12, Nakazaki-Nishi,  
Kita-ku, Osaka, 530-8323 Japan

Tokyo Office:  
JR Shinagawa East Bldg., 2-18-1, Konan,  
Minato-ku, Tokyo, 108-0075 Japan

[http://www.daikin.com/global\\_ac/](http://www.daikin.com/global_ac/)

©All rights reserved