



# REMOVAL PROCEDURE



SERVICE  
MANUAL

S E R V I C E M A N U A L

## 4/5/6/6.5/7 HP Class

-  Outdoor Unit
-  Non-Inverter
-  Pair Type



# **Service Manual Removal Procedure**

## **Outdoor Unit**

### **Applicable Models**

#### **●Cooling Only**

**R36NUY14**

**R42NUY14**

**R48NUY14**

**R51NUY14**

**R56NUY14**

**R36NUY2S**

**R42NUY2S**

**R48NUY2S**

**R51NUY2S**

**R56NUY2S**

**R36NUV2S**

# Table of Contents

- 1. Procedure to Remove Outside Panels.....2
- 2. Procedure to Remove Propeller Fan and Fan Motor .....3
- 3. Procedure to Remove El. Compo. Box .....4
- 4. Procedure to Remove Reverse Phase Protector .....5
- 5. Procedure to Remove Compressor.....6

# 1. Procedure to Remove Outside Panels

**Procedure**



**Warning**

Be sure to wait for 10 minutes or more after turning off all power supplies before disassembling work.

Step	Procedure	Points
1	Pull the lower part (7 positions) of suction grille to your side and dismount 2 screws, then pull up the entire grille to remove it.	
2	To remove the front panel (front part of the side panel), dismount 1 screw, and pull down the panel.	
3	To remove the top panel, dismount 8 screws.	
4	Dismount 1 screw to remove the front panel of piping cover.	
5	Dismount 4 screws to remove the side panel of piping cover.	
6	Dismount 2 screws to remove the rear part of the side panel.	

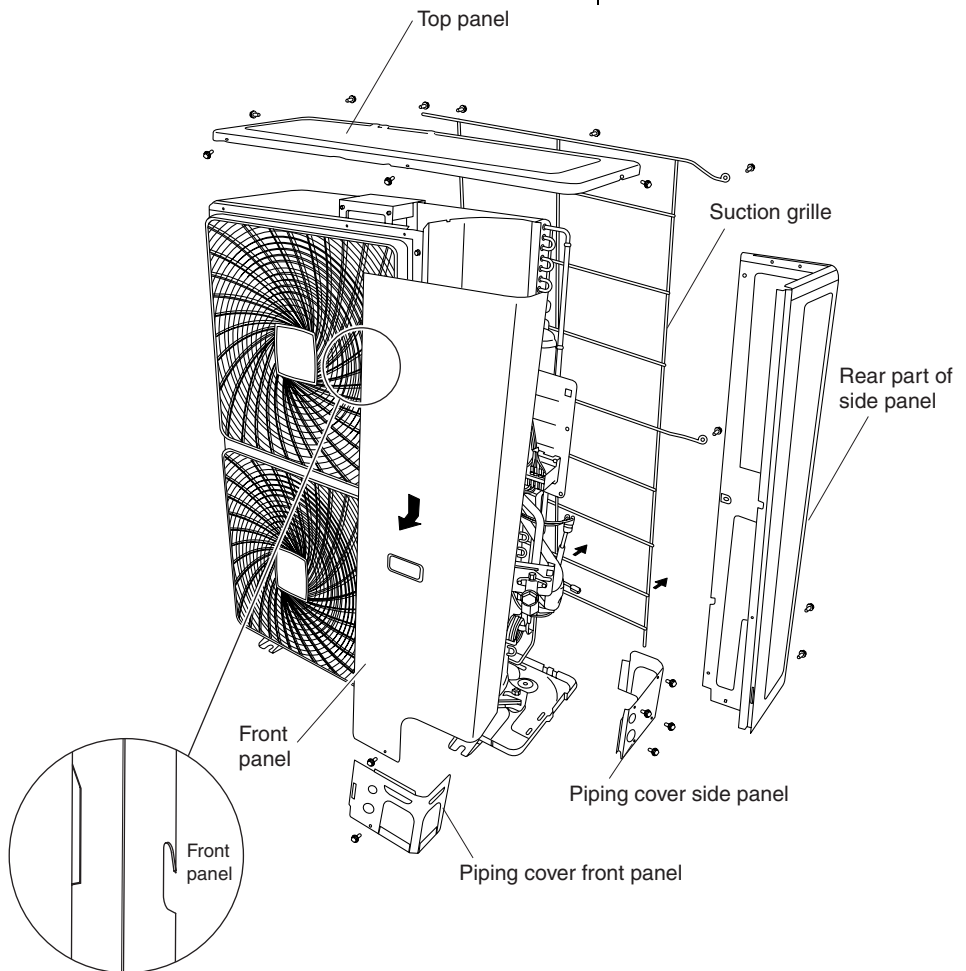

# 2. Procedure to Remove Propeller Fan and Fan Motor

**Procedure**



**Warning** Be sure to wait for 10 minutes or more after turning off all power supplies before disassembling work.

Step	Procedure	Points
<p>■ Removing top panel and front panel according to the "Procedure to Remove Outside Panels".</p>		
<p>1. Removing propeller fan</p> <p>1 Dismount 8 screws fixing discharge grille and disengage 8 hooks located at upper and lower sides of the grille to remove the grille.</p> <p>2 Remove fan stopper and washer faced nut fixing propeller fan.</p>		
<p>2. Removing the fan motor</p> <p>1 Disconnect the connector for fan motor from the El. Compo. Box.</p> <p>2 Pull out the fastening terminal from capacitor (C1R).</p> <p>3 The lead wires are clamped at 2 locations. (1 with tie wrap and 2 with hooks of partition plate)</p> <p>4 Dismount 4 screws for the front panel, and pull the lead wires to separate from other parts.</p> <p>5 Fan motor can be removed by removing 4 fixing bolts.</p>		<p>■ Do not pull the lead wire but hold the connector and press the hook section when disconnect the connector.</p> <p>■ Precautions for installing motor Be sure to fix the motor lead wire with clammers, or the lead wire could be caught with fan resulting damage of parts.</p>

### 3. Procedure to Remove El. Compo. Box

**Procedure**



**Warning**

Be sure to wait for 10 minutes or more after turning off all power supplies before disassembling work.

Step	Procedure	Points
<p>■ Removing top panel and front panel according to the "Procedure to Remove Outside Panels".</p>		
<p>1 Remove following connectors, fastening terminal from compressor, high pressure switch, low pressure switch, fan motor terminals and thermistors according to "Removal of Thermistor".</p> <p>2 Dismount 2 screws fixing the el. compo box.</p> <p>3 To remove the el. compo. box frontward before slide the left side upward.</p>		

# 4. Procedure to Remove Reverse Phase Protector

**Procedure**

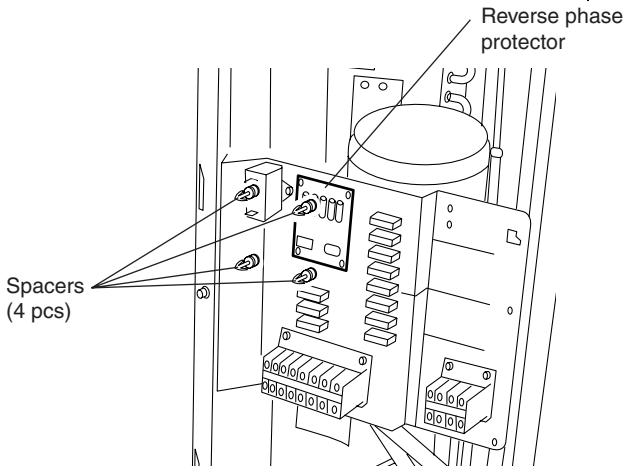
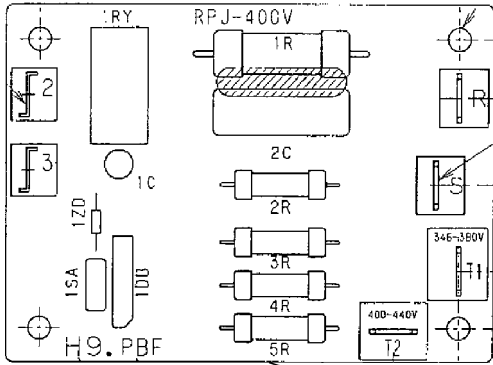

**Warning** Be sure to wait for 10 minutes or more after turning off all power supplies before disassembling work.

Step	Procedure	Points
<p>■ Removing top panel and front panel according to the "Procedure to Remove Outside Panels".</p>		
<p>1 Disconnect all connectors on the reverse phase protector.</p> <p>2 Disconnect reverse phase protector from 4 spacers.</p>	  <p style="text-align: center;">Reverse phase protector</p>	

# 5. Procedure to Remove Compressor

**Procedure**



**Warning**

Be sure to wait for 10 minutes or more after turning off all power supplies before disassembling work.

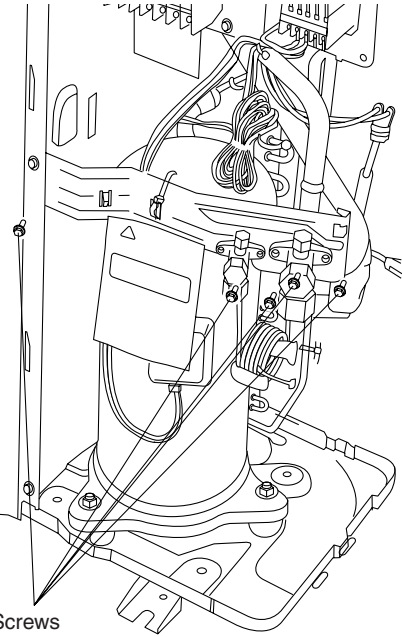
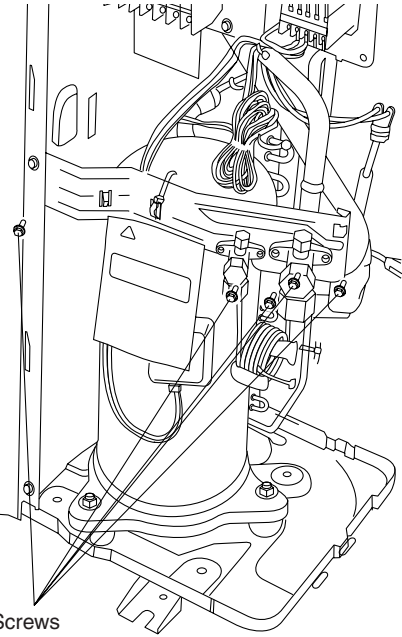
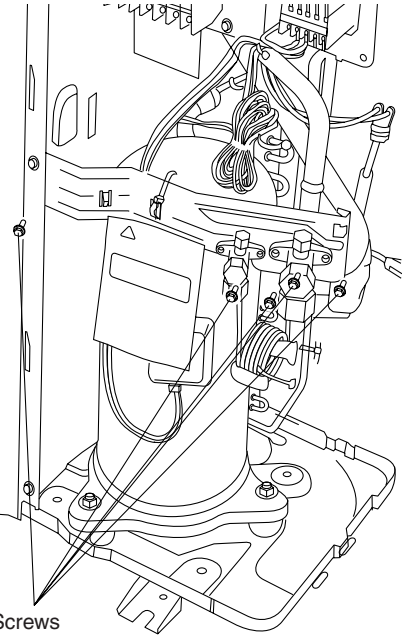
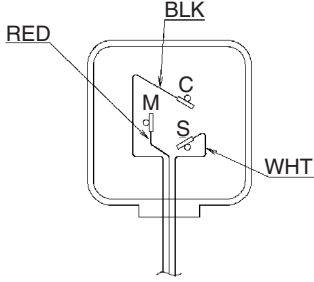
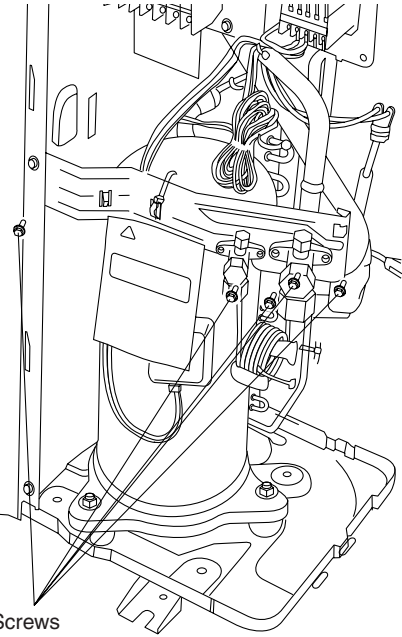
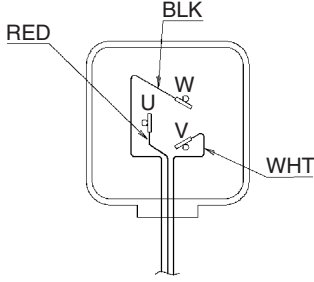
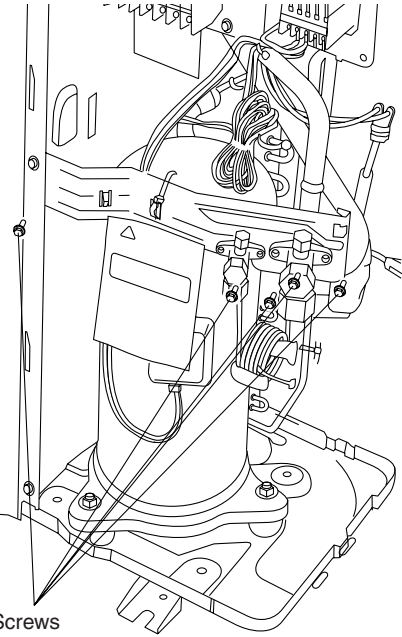
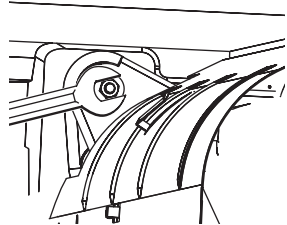
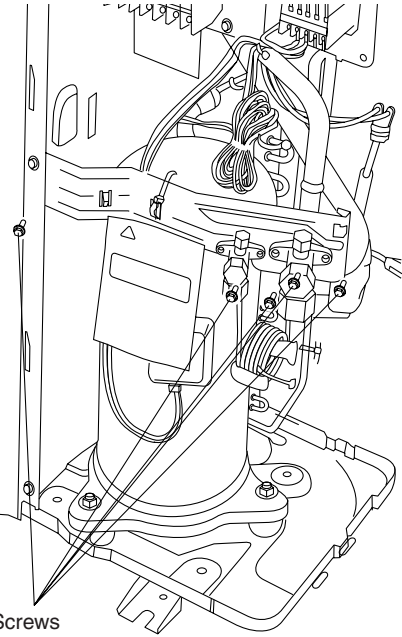
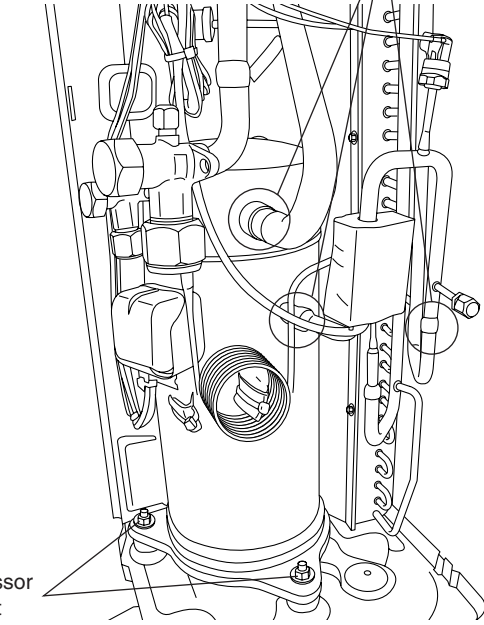
Step	Procedure	Points
<p>■ Removing top panel and front panel according to the "Procedure to Remove Outside Panels".</p>	<p>Stop valve mounting plate</p> 	<p>■ Check that the refrigerant is completely discharged before starting the disassembling work.</p>
<p>1 Dismount 5 screws to remove the stop valve mounting plate.</p>		<p>■ Color of terminal end</p>
<p>2 Disconnect the gas piping and the liquid piping.</p>		<p>■ R36NU</p> 
<p>3 To remove the terminal cover, press the protruded section on both right and left sides.</p>		<p>■ R36~51NU</p> 
<p>4 Disconnect the lead wires from the terminals.</p>		<p>■ 1 of compressor fixing nuts is outside of the partition plate.</p> 
<p>5 Dismount the 3 nuts fixing the compressor.</p>		
<p>6 Disconnect 3 brazed joints.</p> <p>Lift and take out the compressor.</p>	<p>Brazed joints (3 joints)</p>  <p>Compressor fixing nut</p>	



# Revision History

Month / Year	Version	Revised contents
01/2013	Si241313	First edition

Warning



- Daikin products are manufactured for export to numerous countries throughout the world. Prior to purchase, please confirm with your local authorised importer, distributor and/or retailer whether this product conforms to the applicable standards, and is suitable for use, in the region where the product will be used. This statement does not purport to exclude, restrict or modify the application of any local legislation.
  - Ask a qualified installer or contractor to install this product. Do not try to install the product yourself. Improper installation can result in water or refrigerant leakage, electrical shock, fire or explosion.
  - Use only those parts and accessories supplied or specified by Daikin. Ask a qualified installer or contractor to install those parts and accessories. Use of unauthorised parts and accessories or improper installation of parts and accessories can result in water or refrigerant leakage, electrical shock, fire or explosion.
  - Read the User's Manual carefully before using this product. The User's Manual provides important safety instructions and warnings. Be sure to follow these instructions and warnings.
- If you have any enquiries, please contact your local importer, distributor and/or retailer.

### Cautions on product corrosion

1. Air conditioners should not be installed in areas where corrosive gases, such as acid gas or alkaline gas, are produced.
2. If the outdoor unit is to be installed close to the sea shore, direct exposure to the sea breeze should be avoided. If you need to install the outdoor unit close to the sea shore, contact your local distributor.



JMI-0107

Organization:  
DAIKIN INDUSTRIES, LTD.  
AIR CONDITIONING MANUFACTURING DIVISION

Scope of Registration:  
THE DESIGN/DEVELOPMENT AND MANUFACTURE OF  
COMMERCIAL AIR CONDITIONING, HEATING, COOLING,  
REFRIGERATING EQUIPMENT, HEATING EQUIPMENT,  
RESIDENTIAL AIR CONDITIONING EQUIPMENT, HEAT  
RECLAIM VENTILATION, AIR CLEANING EQUIPMENT,  
COMPRESSORS AND VALVES.



JQA-1452

Organization:  
DAIKIN INDUSTRIES  
(THAILAND) LTD.

Scope of Registration:  
THE DESIGN/DEVELOPMENT  
AND MANUFACTURE OF AIR  
CONDITIONERS AND THE  
COMPONENTS INCLUDING  
COMPRESSORS USED FOR THEM



EC99J2044

All of the Daikin Group's business facilities and subsidiaries in Japan are certified under the ISO 14001 international standard for environment management.

### Dealer

### DAIKIN INDUSTRIES, LTD.

Head Office:  
Umeda Center Bldg., 2-4-12, Nakazaki-Nishi,  
Kita-ku, Osaka, 530-8323 Japan

Tokyo Office:  
JR Shinagawa East Bldg., 2-18-1, Konan,  
Minato-ku, Tokyo, 108-0075 Japan

[http://www.daikin.com/global\\_ac/](http://www.daikin.com/global_ac/)

©All rights reserved