



REMOVAL PROCEDURE



S E R V I C E M A N U A L

2.5/3/4/5/6 HP Class

-  Indoor Unit
-  Non-Inverter
-  Ceiling Suspended Type



Service Manual Removal Procedure

Indoor Unit

Indoor Models

●Cooling Only

**FH21NUV14
FH26NUV14
FH36NUV14
FH42NUV14
FH48NUV14
FH36NUV2S
FH42NUV2S
FH48NUV2S**

Table of Contents

1. Procedure to Remove Air Filter and Suction Grille	2
2. Procedure to Remove Electrical Parts and PCB.....	3
3. Procedure to Remove Horizontal Blade	5
4. Procedure to Remove Fan Rotor and Motor	6
5. Procedure to Remove Fan Bearing.....	8
6. Procedure to Remove Bottom Panel and Drain Pan.....	9
7. Procedure to Remove Swing Motor	10

1. Procedure to Remove Air Filter and Suction Grille

Procedure



Warning Be sure to wait for 10 minutes or more after turning off all power supplies before disassembling work.

Step	Procedure	Points
1	Press the 2 tabs and open the suction grilles.	
2	Press the air filter installation panel from 2 places in the direction of the arrow, and pull the air filter out toward yourself.	
3	Grip the suction grille hinge strongly and remove the suction grille.	

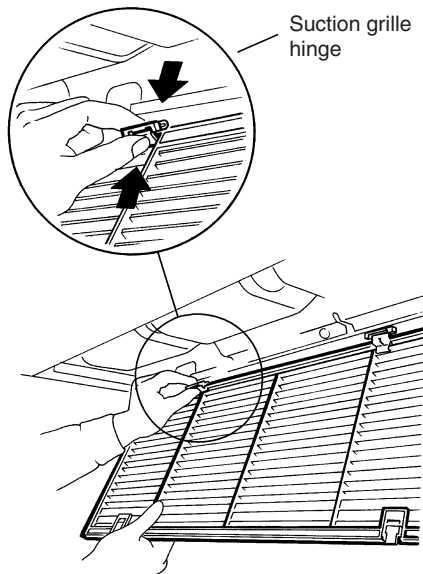
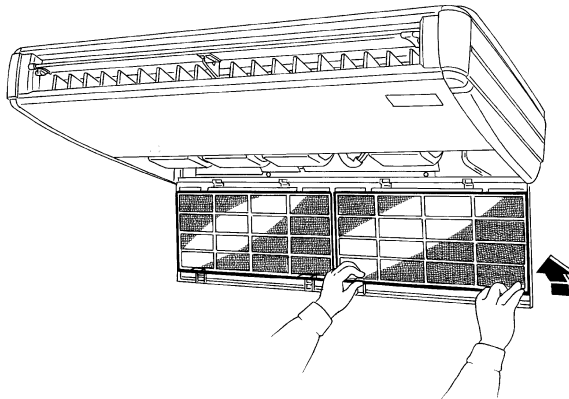
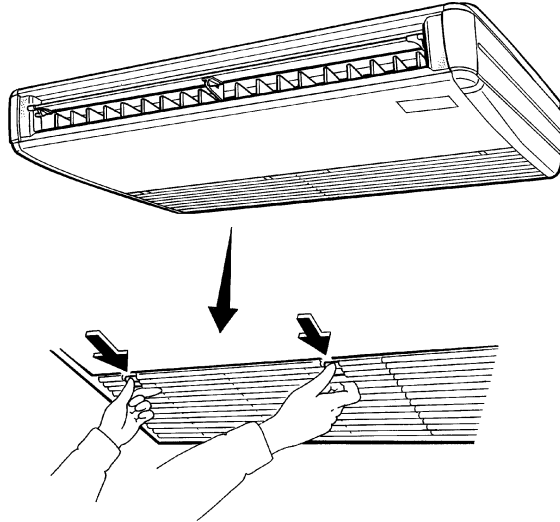

2. Procedure to Remove Electrical Parts and PCB

Procedure

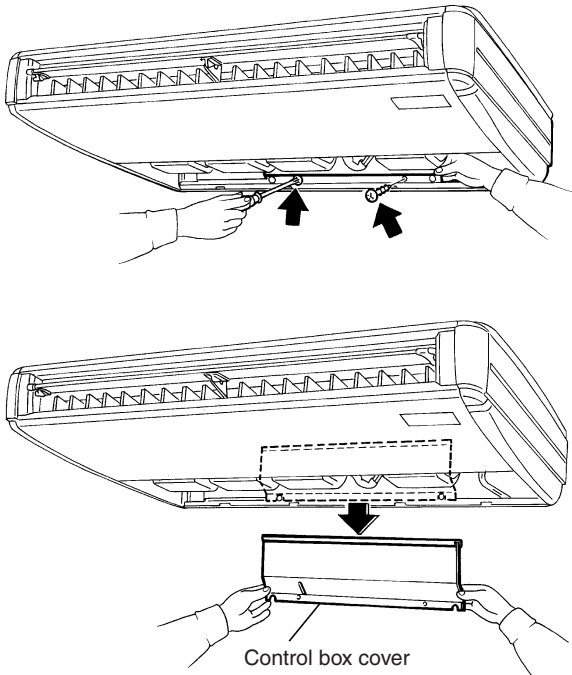
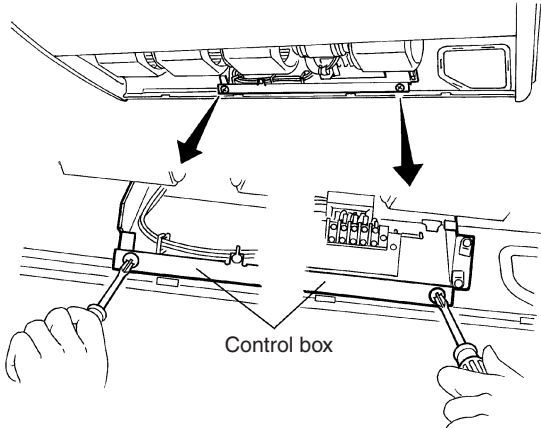
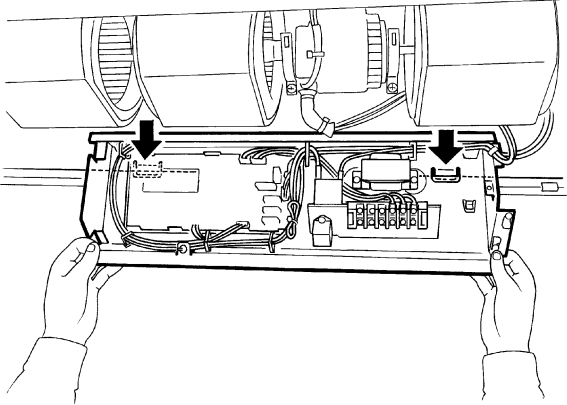
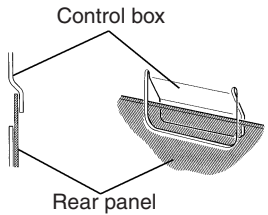

Warning Be sure to wait for 10 minutes or more after turning off all power supplies before disassembling work.

Step	Procedure	Points
1	<p>Loosen the 2 screws of the control box cover and remove the control box cover.</p>  <p style="text-align: center;">Control box cover</p>	
2	<p>Remove the 2 screws of the control box.</p>  <p style="text-align: center;">Control box</p>	
3	<p>Pull down the control box and let it hang by the 2 locations in the rear. Electrical parts can now be removed.</p> 	 <p style="text-align: center;">Control box Rear panel</p>

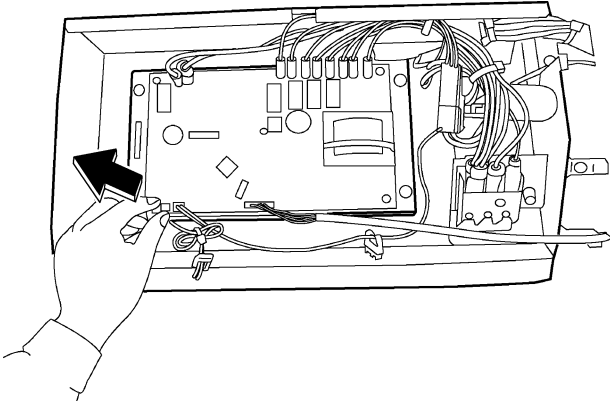
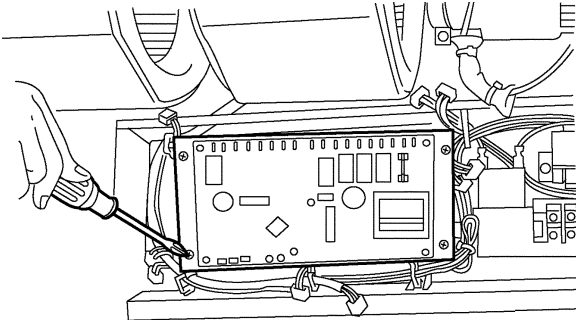
Step	Procedure	Points
4	<p>Disconnect all connector mounted on the PCB.</p> 	
5	<p>Remove the PCB installation screw. (4 Point)</p> 	

3. Procedure to Remove Horizontal Blade

Procedure



Warning

Be sure to wait for 10 minutes or more after turning off all power supplies before disassembling work.

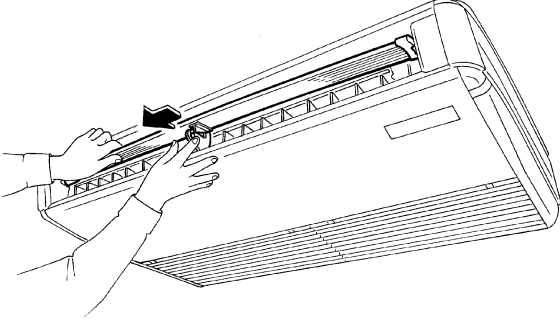
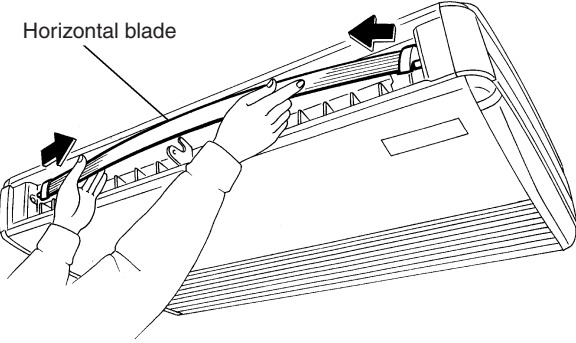
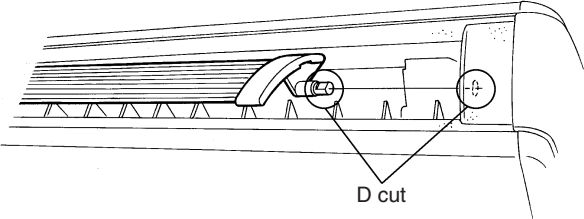
Step	Procedure	Points
1	<p>Gently bend the support plate located at the center of the horizontal blade, and detach the center shaft. (2 shafts provided on Types 36, 42 and 48.)</p> 	
2	<p>Then gently bend the center of the horizontal blade, and take both the end shafts out of their bearings.</p> 	<p>* When removing the horizontal blade from the bearings at both ends, be careful not to get the blow port thermal insulation scratched.</p>
Reassembling precautions		
1	<p>The shaft at the right end of the horizontal blade is cut in D shape. Fit this D-shaped end to the D-profiled bearing. Reattach the horizontal blade at the right side first.</p> 	

4. Procedure to Remove Fan Rotor and Motor

Procedure



Warning

Be sure to wait for 10 minutes or more after turning off all power supplies before disassembling work.

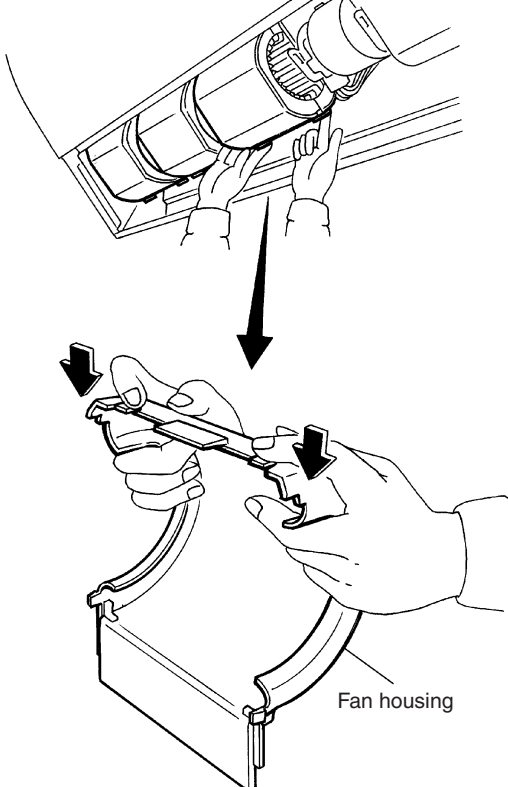
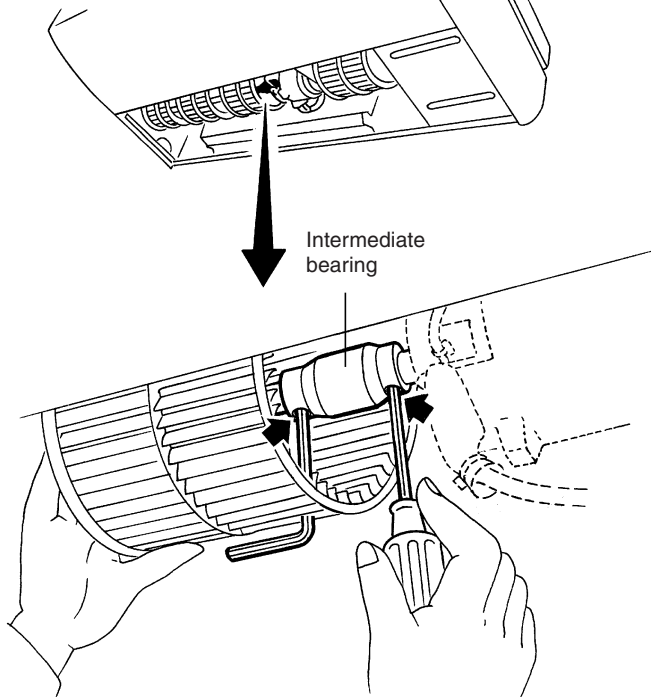
Step	Procedure	Points
1	<p>Press the 2 tabs of the fan housing toward the inside with your fingers, and pull out the fan housing.</p> 	
2	<p>Loosen the 2 hexagon set screws of the intermediate bearing.</p> 	

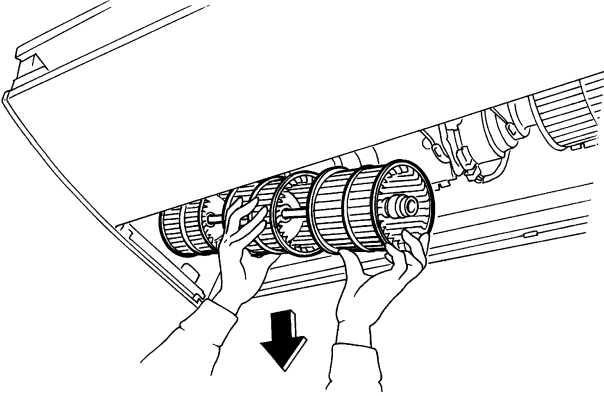
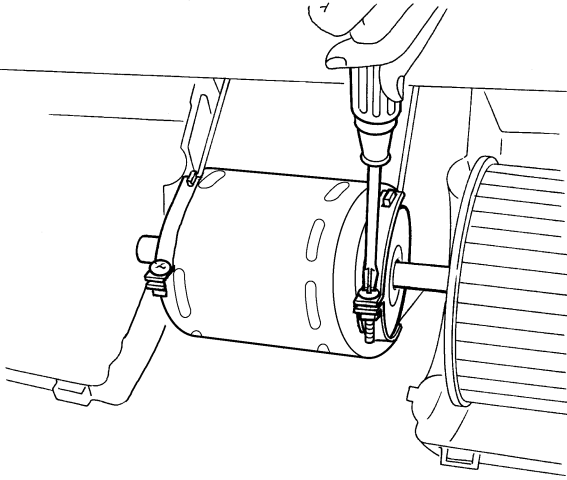
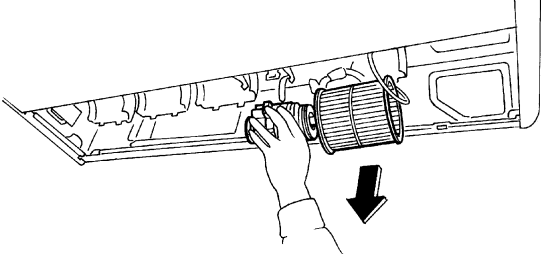
Step	Procedure	Points
3	<p>Slide the intermediate bearing to the right and remove the fan rotor assy.</p> 	
4	<p>Remove the 2 fan motor fasteners.</p> 	
5	<p>Remove the fan motor.</p> 	<p>* Finally reconnect the fan motor connector, cover it with the glass tube and secure it with the tie-wrap.</p>

5. Procedure to Remove Fan Bearing

Procedure



Warning

Be sure to wait for 10 minutes or more after turning off all power supplies before disassembling work.

Step	Procedure	Points
* Remove the fan rotor according to the procedures to remove the fan rotor and fan motor.	<p>Fan rotor</p> <p>Left side panel</p>	
1	Remove the left side panel installation screw.	
	<p>Left side panel</p> <p>①</p>	
2	Slide the left side panel toward the front of the unit and remove.	
3	Remove the 2 bearing installation screws and remove the bearing.	
	<p>Left side panel</p> <p>②</p> <p>Bearing</p> <p>③</p>	

6. Procedure to Remove Bottom Panel and Drain Pan

Procedure



Warning

Be sure to wait for 10 minutes or more after turning off all power supplies before disassembling work.

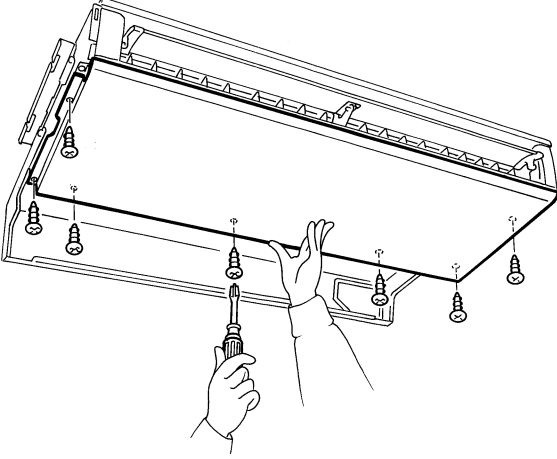
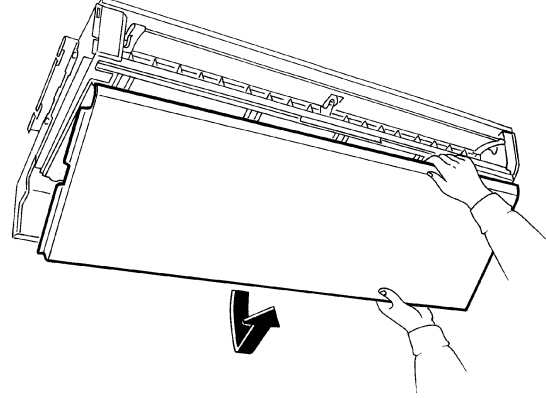
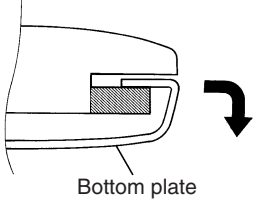
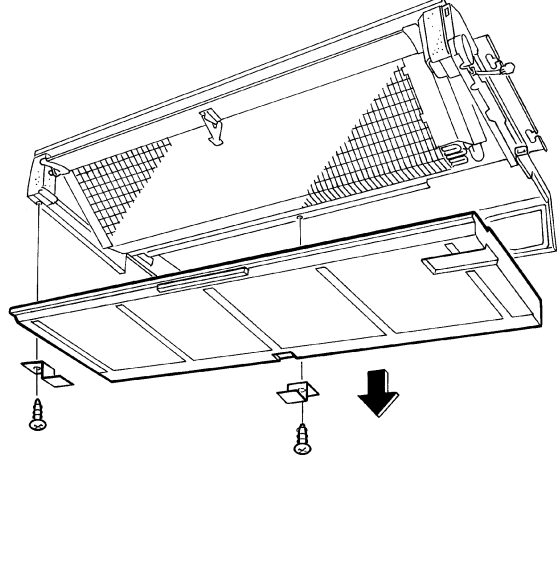
Step	Procedure	Procedure	Points
5	Remove the 7 bottom panel installation screws (2 each on the left and right, 3 in the rear), and remove the bottom panel.		Remove the rear surface screws (2 each on the left and right), and remove the center screw while supporting the bottom panel from underneath.
6	Let down the rear of the bottom panel, press out toward the front (removed from the hooking part) and remove.		
7	Remove the drain pan retainer (2 screw).		

7. Procedure to Remove Swing Motor

Procedure



Warning

Be sure to wait for 10 minutes or more after turning off all power supplies before disassembling work

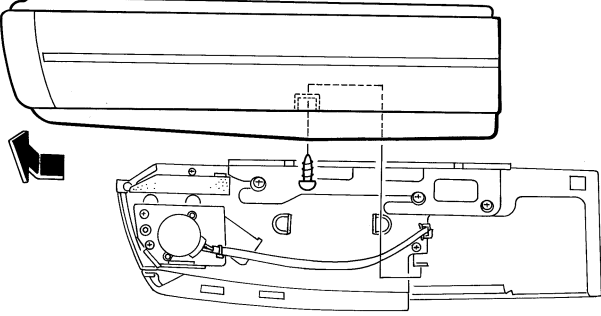
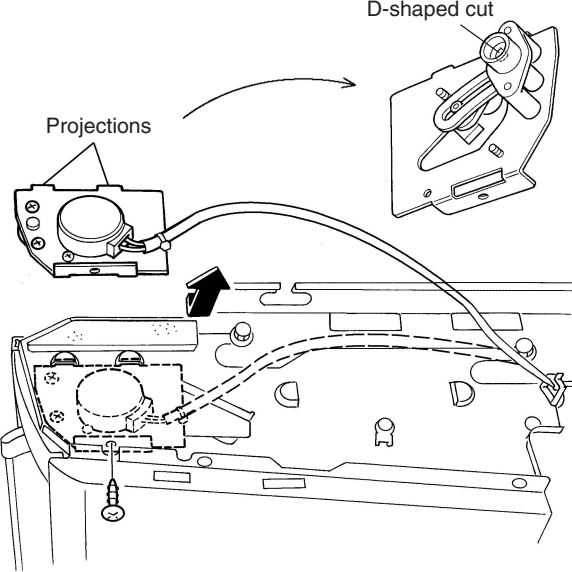
Step	Procedure	Points
<p>1 Remove the screw from the right side panel. Slide the right side panel toward the front and detach it.</p> <p>2 Disconnect the connector of swing motor from PCB.</p>		
<p>3 Remove the screw from the swing motor. The swing motor has 2 projections on it. Lower the swing motor and take it out.</p>		

Revision History

Month / Year	Version	Revised contents
01/2013	Si241304	First edition

Warning



- Daikin products are manufactured for export to numerous countries throughout the world. Prior to purchase, please confirm with your local authorised importer, distributor and/or retailer whether this product conforms to the applicable standards, and is suitable for use, in the region where the product will be used. This statement does not purport to exclude, restrict or modify the application of any local legislation.
- Ask a qualified installer or contractor to install this product. Do not try to install the product yourself. Improper installation can result in water or refrigerant leakage, electrical shock, fire or explosion.
- Use only those parts and accessories supplied or specified by Daikin. Ask a qualified installer or contractor to install those parts and accessories. Use of unauthorised parts and accessories or improper installation of parts and accessories can result in water or refrigerant leakage, electrical shock, fire or explosion.
- Read the User's Manual carefully before using this product. The User's Manual provides important safety instructions and warnings. Be sure to follow these instructions and warnings.

If you have any enquiries, please contact your local importer, distributor and/or retailer.

Cautions on product corrosion

1. Air conditioners should not be installed in areas where corrosive gases, such as acid gas or alkaline gas, are produced.
2. If the outdoor unit is to be installed close to the sea shore, direct exposure to the sea breeze should be avoided. If you need to install the outdoor unit close to the sea shore, contact your local distributor.



JMI-0107

Organization:
DAIKIN INDUSTRIES, LTD.
AIR CONDITIONING MANUFACTURING DIVISION

Scope of Registration:
THE DESIGN/DEVELOPMENT AND MANUFACTURE OF
COMMERCIAL AIR CONDITIONING, HEATING, COOLING,
REFRIGERATING EQUIPMENT, HEATING EQUIPMENT,
RESIDENTIAL AIR CONDITIONING EQUIPMENT, HEAT
RECLAIM VENTILATION, AIR CLEANING EQUIPMENT,
COMPRESSORS AND VALVES.



JQA-1452

Organization:
DAIKIN INDUSTRIES
(THAILAND) LTD.

Scope of Registration:
THE DESIGN/DEVELOPMENT
AND MANUFACTURE OF AIR
CONDITIONERS AND THE
COMPONENTS INCLUDING
COMPRESSORS USED FOR THEM



EC99J2044

All of the Daikin Group's business facilities and subsidiaries in Japan are certified under the ISO 14001 international standard for environment management.

Dealer

DAIKIN INDUSTRIES, LTD.

Head Office:
Umeda Center Bldg., 2-4-12, Nakazaki-Nishi,
Kita-ku, Osaka, 530-8323 Japan

Tokyo Office:
JR Shinagawa East Bldg., 2-18-1, Konan,
Minato-ku, Tokyo, 108-0075 Japan

http://www.daikin.com/global_ac/

©All rights reserved