





Si211306E

REMOVAL PROCEDURE



S E R V I C E M A N U A L

3 HP Class

-  Indoor Unit
-  Non-Inverter
-  Pair Type

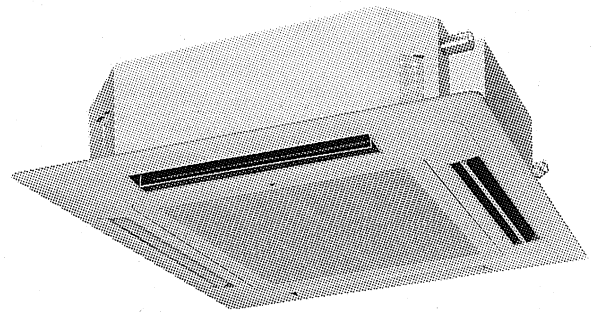

Service Manual Removal Procedure

Indoor Unit

Applicable Models

- Heat Pump
FHYC71KVE

Table of Contents

1. Procedure to Remove Switch Box Cover.....	2
2. Procedure to Remove Fan Motor.....	3
3. Procedure to Remove Suction Grille.....	4
4. Procedure to Remove Air Filter.....	5
5. Procedure to Remove Decoration Cover	6
6. Procedure to Remove Decoration Panel.....	7
7. Procedure to Remove Horizontal Vane.....	8
8. Procedure to Remove Swing Motor	10
9. Procedure to Remove Switch Box Cover.....	12
10. Procedure to Remove Fan Motor.....	13
11. Procedure to Remove Drain Pan	14
12. Procedure to Remove Drain Pump and Drain Hose	15

1. Procedure to Remove Switch Box Cover

Procedure



Warning

Be sure to wait for 10 minutes or more after turning off all power supplies before disassembling work.

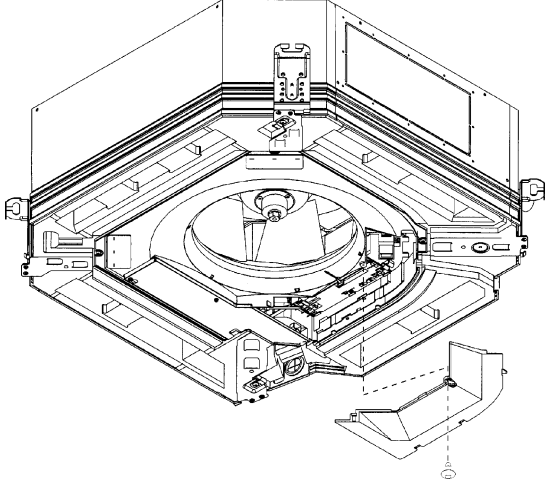
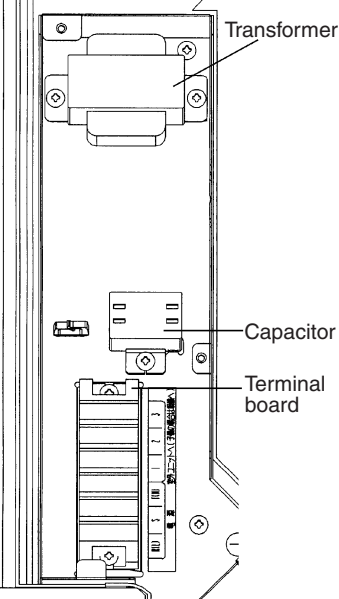
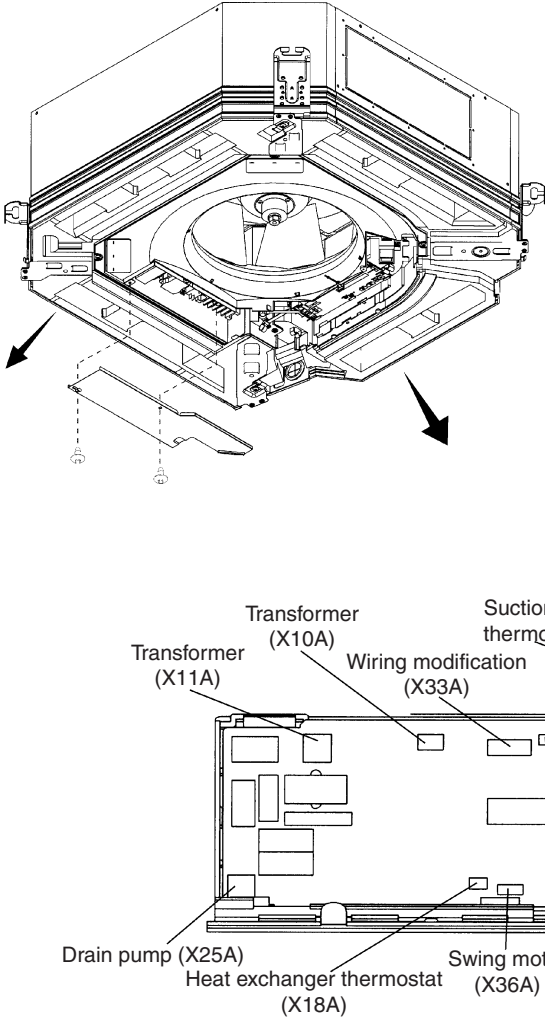
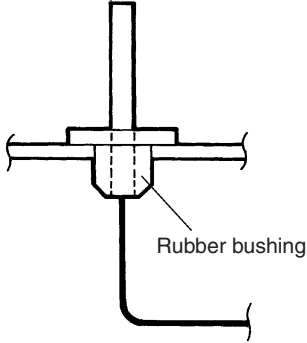
Step	Procedure	Points
<p>1. Removing the cover from the control PCB side</p> <p>1 Loosen the 1 screw, and pull the cover toward the inside and pull it down.</p>		
<p>2. Removing the cover from the connection wire side</p> <p>1 Remove 1 screw and loosen the other screw. Pull the cover toward the pipe, then pull it down.</p> 		<p>*Caution during installation</p>  <p>Rubber bushing</p> <p>Set the thermistor base securely on the rubber bushing.</p>

2. Procedure to Remove Fan Motor

Procedure



Warning

Be sure to wait for 10 minutes or more after turning off all power supplies before disassembling work.

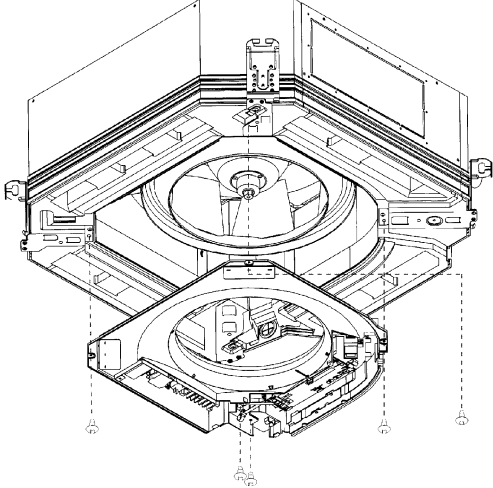
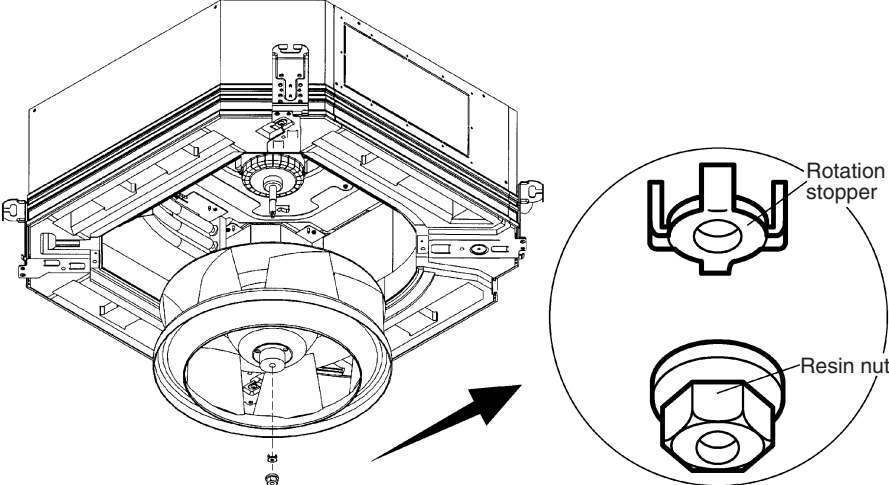
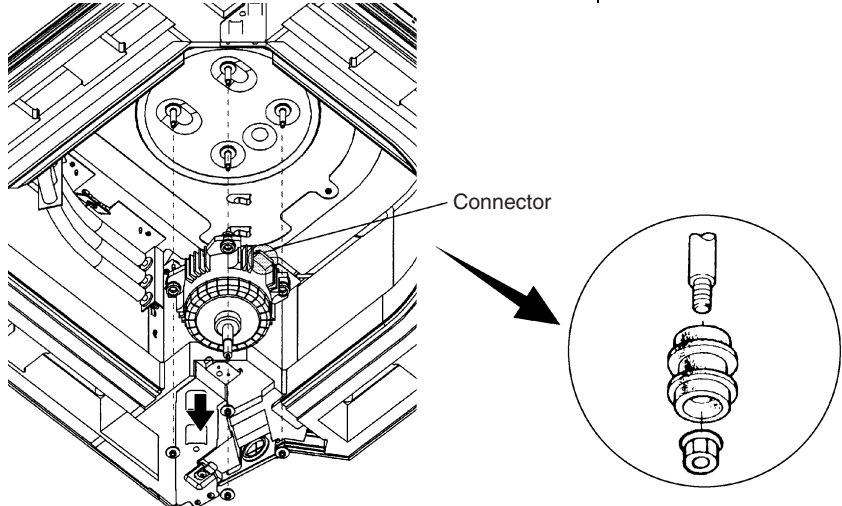
Step	Procedure	Points
1. Removing the switch box 1 Remove the 5 screws, and pull the switch box down.		
2. Removing the fan 1 Remove the resin nut and rotation stopper from the fan.		
3. Removing the fan motor 1 Remove the washer-based nuts. *3 nuts in FHYC35 - 71K *4 nuts in FHYC100 - 125K		

3. Procedure to Remove Suction Grille

Procedure



Warning

Be sure to wait for 10 minutes or more after turning off all power supplies before disassembling work.

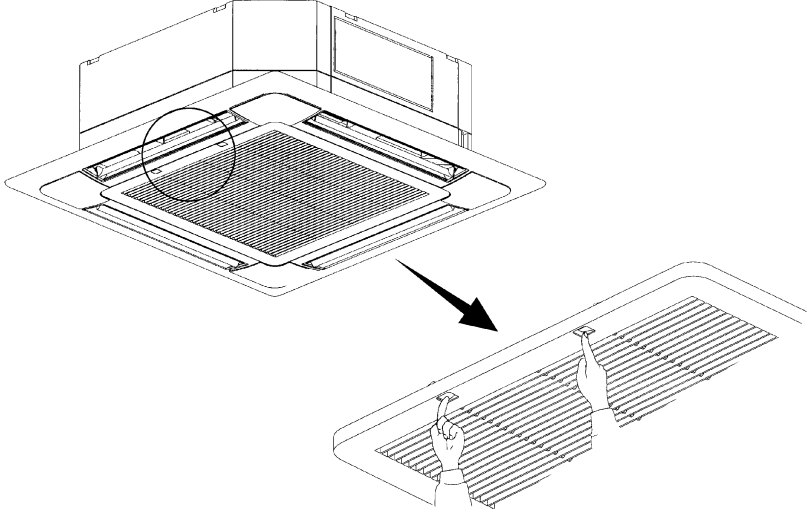
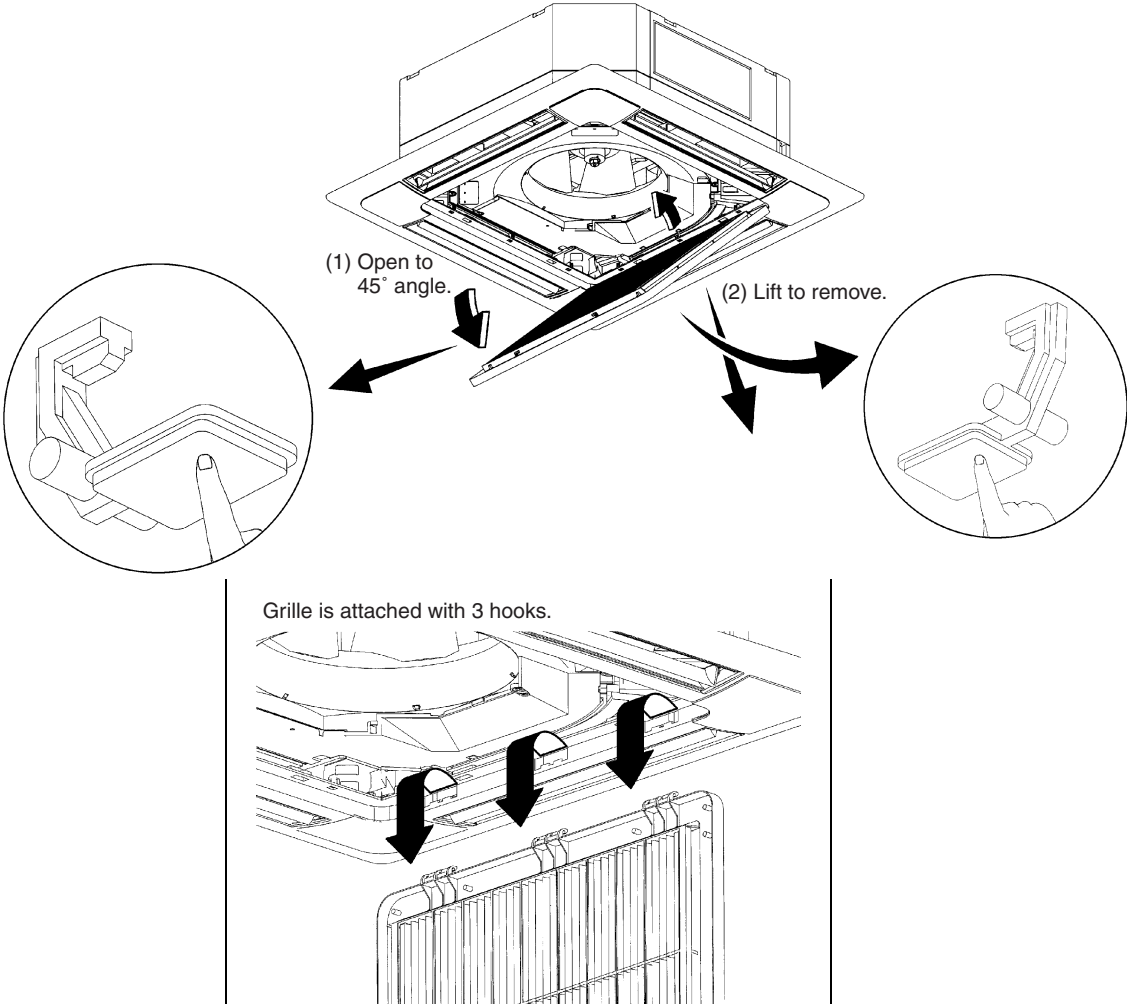
Step	Procedure	Points
1	<p>Push the 2 buttons simultaneously and pull the suction grille down slowly.</p> 	<p>*When closing, push up the grille slowly.</p>
2	<p>With the suction grille open at an angle of 45°, lift it up to remove it.</p>  <p>(1) Open to 45° angle.</p> <p>(2) Lift to remove.</p> <p>Grille is attached with 3 hooks.</p>	

4. Procedure to Remove Air Filter

Procedure



Warning

Be sure to wait for 10 minutes or more after turning off all power supplies before disassembling work.

Step	Procedure	Points
1 Open the suction grille. (See the removal procedure of suction grille.) 2 Disengage the hooks of the air filter by pulling the filter downward at an angle, and remove the filter.		
*Installation of the air filter (2)	1 Hook the air filter to the protrusions located at the top section of the suction grille. 2 Push the lower section of the air filter into the protrusions located at the bottom section of the suction grille to secure the air filter in place.	

5. Procedure to Remove Decoration Cover

Procedure



Warning

Be sure to wait for 10 minutes or more after turning off all power supplies before disassembling work.

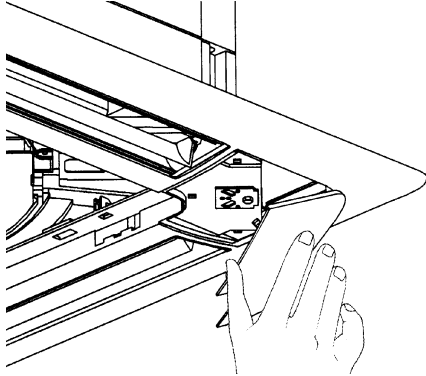
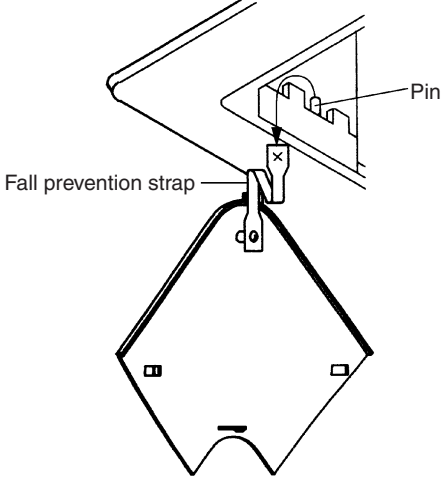
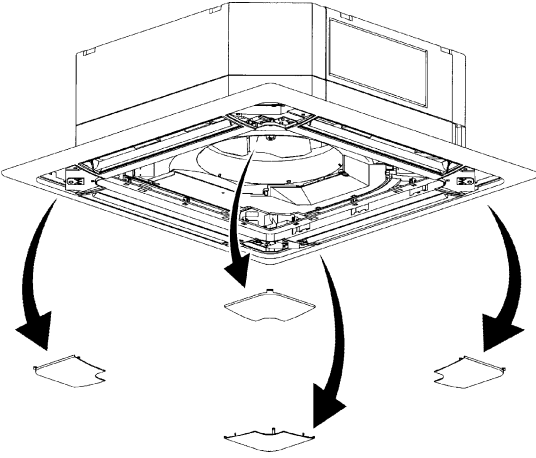
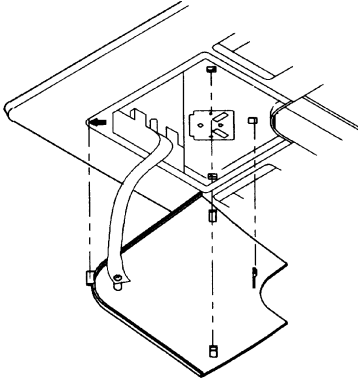
Step	Procedure	Points
1	<p>To remove the decoration cover, pull the inside part (suction grille side) down.</p> 	
2	<p>Disengage the strap (fall prevention strap) of the corner decoration cover from the pin.</p> 	
3	<p>There are 4 corner decoration covers. They can be removed by following the same procedure.</p> 	<p>*Installation of the corner decoration cover Install the corner decoration cover so that the 4 protrusions on the cover are securely inserted into the holes on the decoration panel section.</p> 

6. Procedure to Remove Decoration Panel

Procedure



Warning

Be sure to wait for 10 minutes or more after turning off all power supplies before disassembling work.

Step	Procedure	Points
1	Loosen the 4 retaining screws from the decoration panel.	Structure of mounting fixture
2	The decoration panel is attached with 4 mounting fixtures.	<p>(1) Retaining screw</p>
3	Remove the 2 fixtures on the outside (sections A), then remove the 2 fixtures on the inside (sections B).	
4	Remove the decoration panel.	

7. Procedure to Remove Horizontal Vane

Procedure



Warning

Be sure to wait for 10 minutes or more after turning off all power supplies before disassembling work.

Step	Procedure	Points
1	Locate 9 screws on the decoration panel under the seal materials.	<p>*Remove seal materials in the following sequence. ②→④,①→③</p> <p>*Number of screws No. of screws</p> <p>Seal material ① : 7 pcs Seal material ② : 9 pcs Seal material ③ : 7 pcs Seal material ④ : 9 pcs Total : 32 pcs</p>
2	There are 23 other screws.	
3	Remove the 18 screws on the swing motor side and on the opposite side to open the covers.	

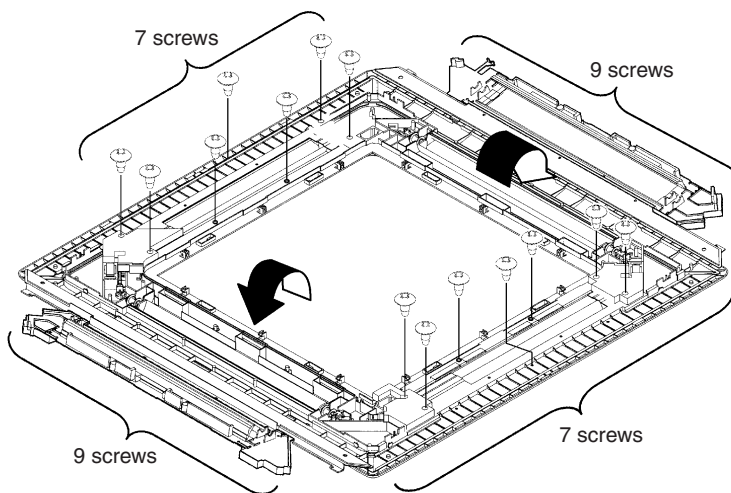
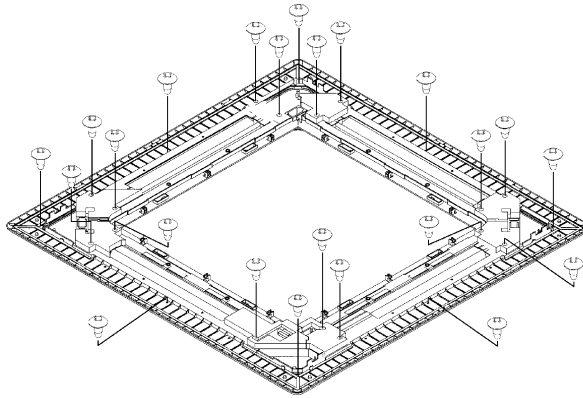
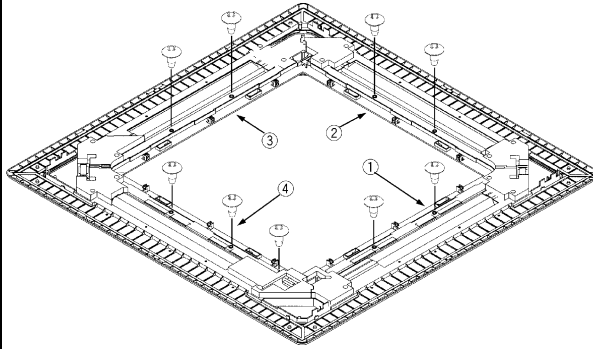

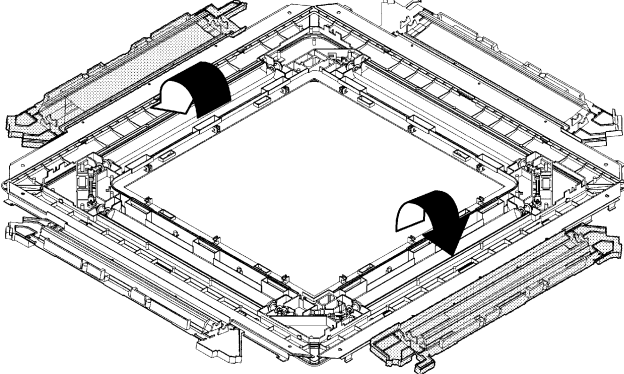
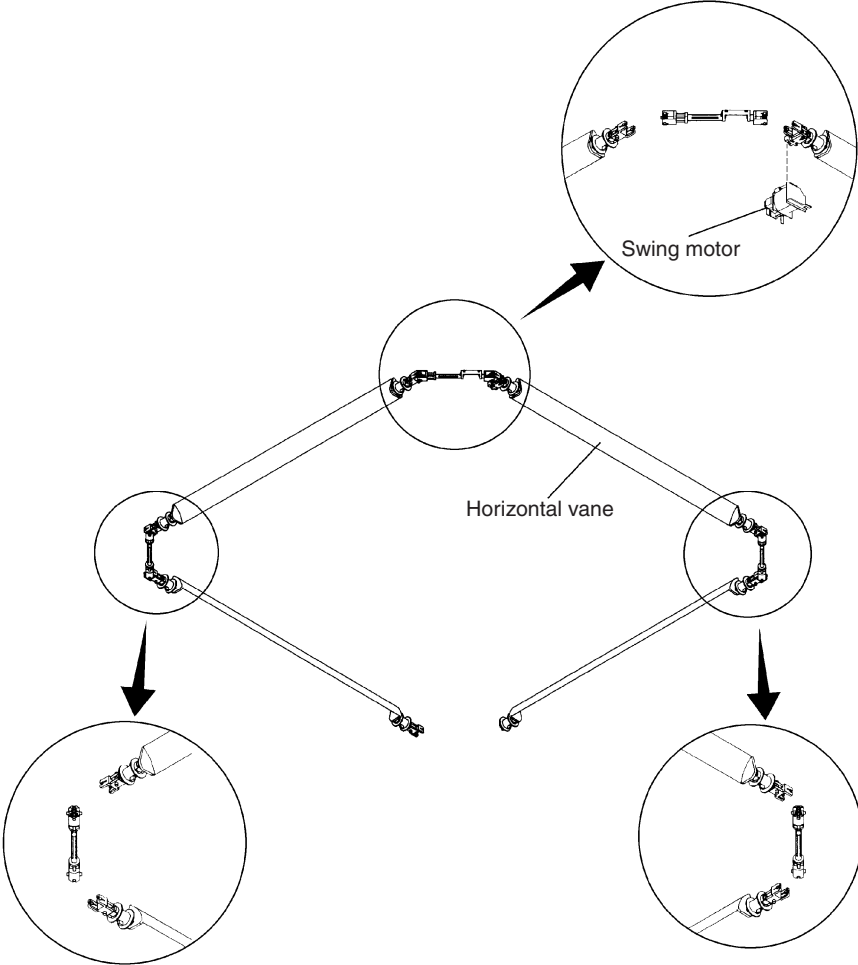
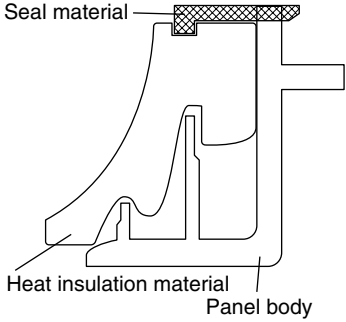
Step	Procedure	Points
4	<p>Remove the 14 screws on the 2 remaining sides and open the covers.</p> 	
	 <p>Swing motor</p> <p>Horizontal vane</p>	<p>Reassembly *Check to make sure the heat insulation is installed in the air outlet section as shown below. (Improper heat insulation installation results in condensation of water.)</p>  <p>Seal material</p> <p>Heat insulation material</p> <p>Panel body</p>

8. Procedure to Remove Swing Motor

Procedure



Warning

Be sure to wait for 10 minutes or more after turning off all power supplies before disassembling work.

Step	Procedure	Points
1	Remove the decoration cover located immediately below the cooling pipe.	*Only the decoration cover needs to be removed to take out the swing motor.
2	Remove the 1 swing motor mounting screw.	
3	Hold the tabs pushed toward the direction of the arrow and pull the motor down.	

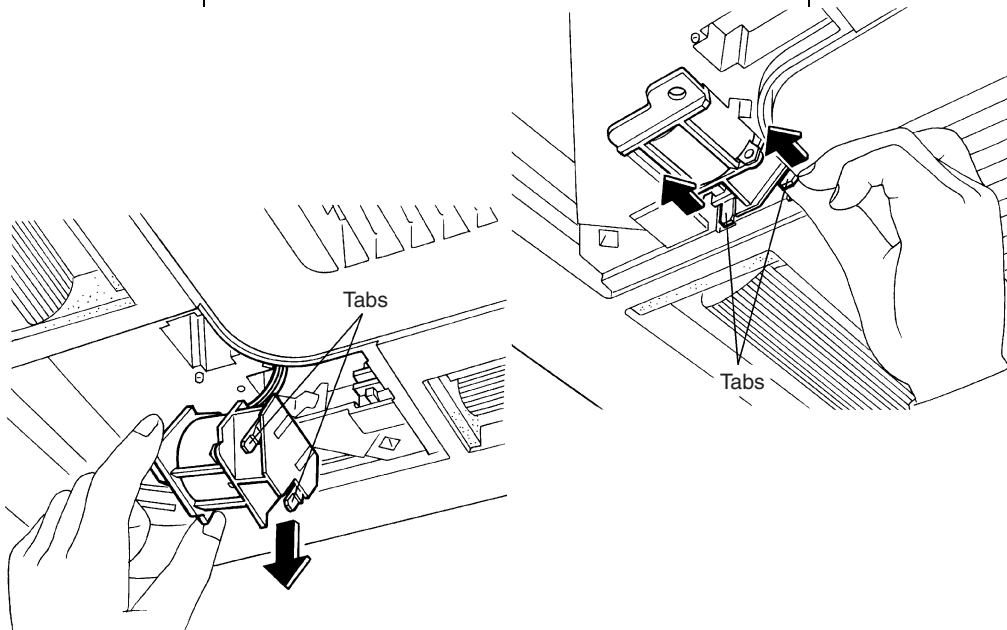
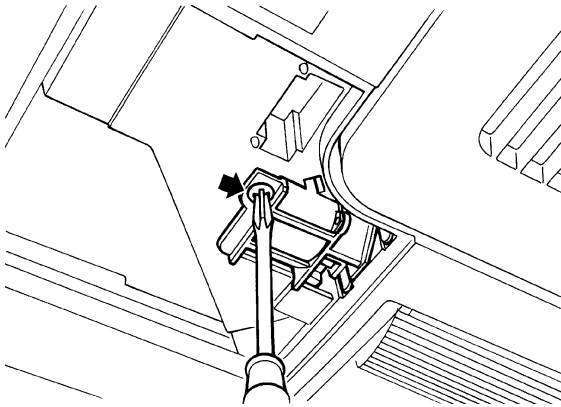
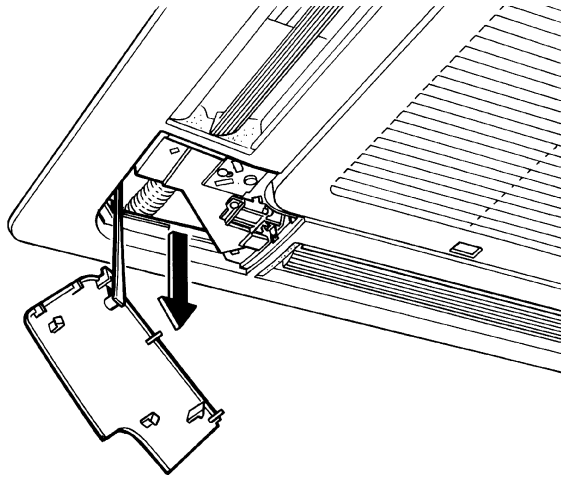

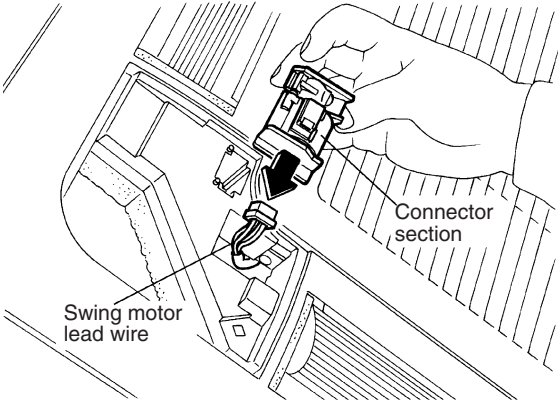
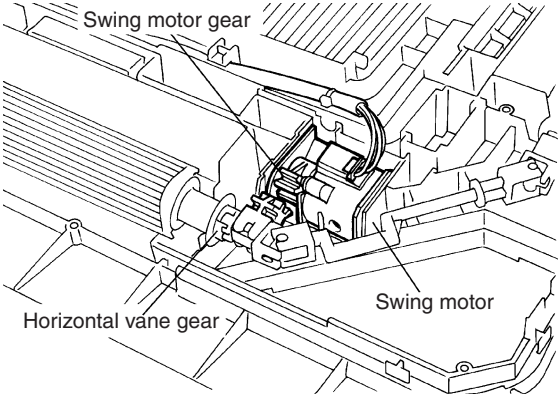
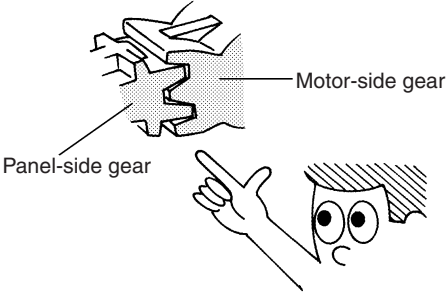
Step	Procedure	Points
4	<p>Disconnect the connector of the swing motor.</p>  <p>Labels: Connector section, Swing motor lead wire</p>	
<p>⚠ Caution *Caution during swing motor installation</p> <p>1 After installing the swing motor, be sure to turn on the power switch for reset (for initializing the vane positions).</p> <p>2 Be sure to engage the gears on the motor side and panel sides. (Improper gear engagement results in faulty swing operation and abnormal noise.)</p>	 <p>Labels: Swing motor gear, Horizontal vane gear, Swing motor</p>  <p>Labels: Motor-side gear, Panel-side gear</p>	

9. Procedure to Remove Switch Box Cover

Procedure



Warning

Be sure to wait for 10 minutes or more after turning off all power supplies before disassembling work.

Step	Procedure	Points
1. Removing the cover from the control PCB side		
1 Loosen the 1 screw, and pull the cover toward the inside and pull it down.		
2. Removing the cover from the connection wire side		<p>! Caution *Caution during installation</p> <p>Rubber bushing</p> <p>Set the thermistor base securely on the rubber bushing.</p>
1 Remove 1 screw and loosen the other screw. Pull the cover toward the pipe, then pull it down		

10. Procedure to Remove Fan Motor

Procedure



Warning

Be sure to wait for 10 minutes or more after turning off all power supplies before disassembling work.

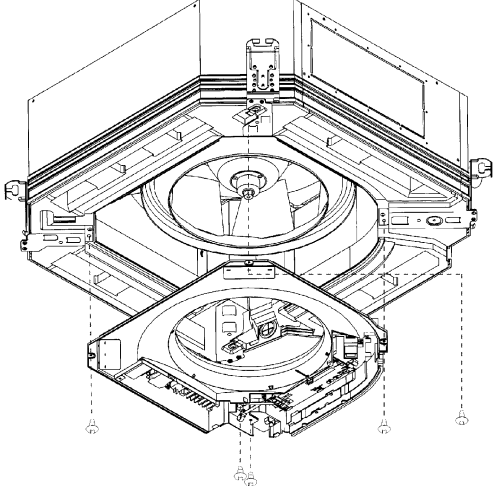
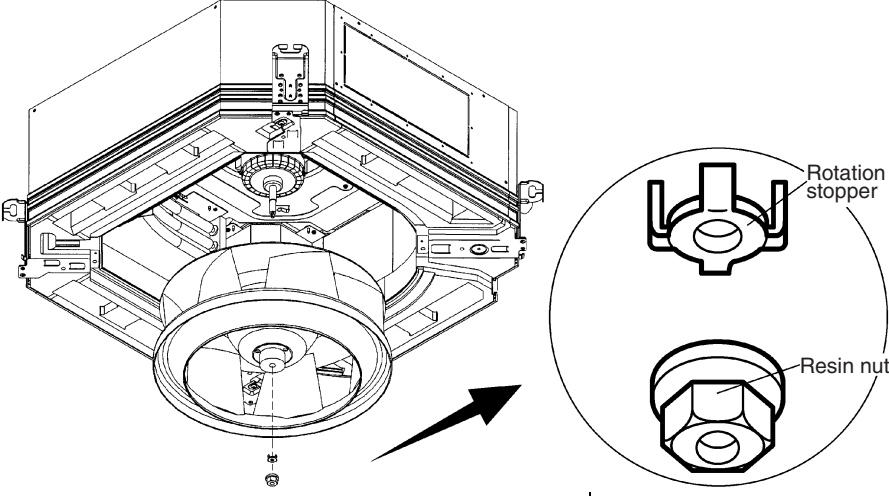
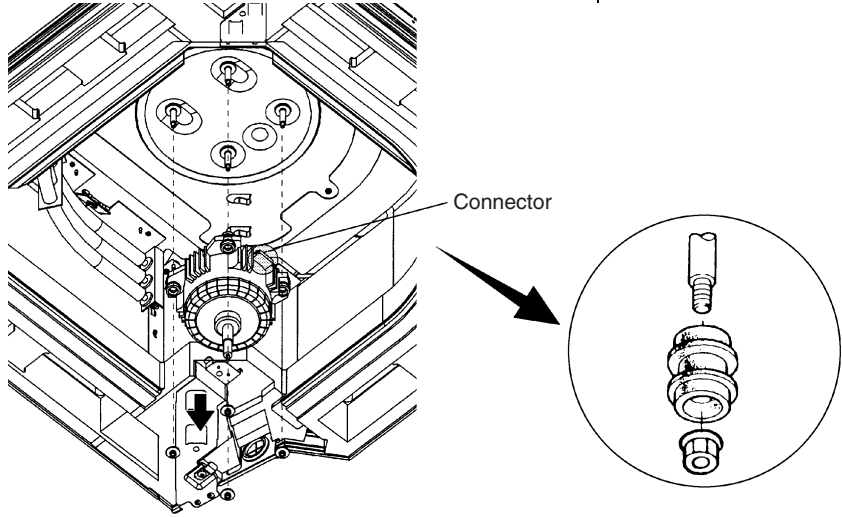
Step	Procedure	Points
1. Removing the switch box 1 Remove the 5 screws, and pull the switch box down.		
2. Removing the fan 1 Remove the resin nut and rotation stopper from the fan.		
3. Removing the fan motor 1 Remove the washer-based nuts. *3 nuts in FHYC35 - 71K *4 nuts in FHYC100 - 125K		

11.Procedure to Remove Drain Pan

Procedure



Warning

Be sure to wait for 10 minutes or more after turning off all power supplies before disassembling work.

Step	Procedure	Points
1	Drain water from the drain hole.	
2	Remove the 5 drain pan mounting screws.	
3	Pull down the drain pan straight down.	

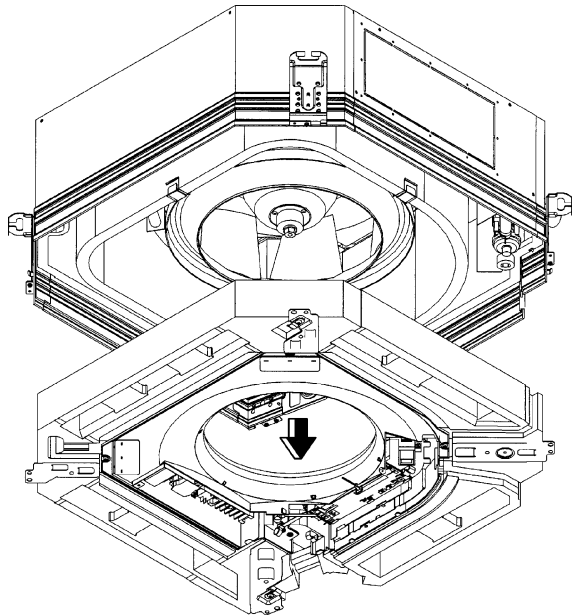
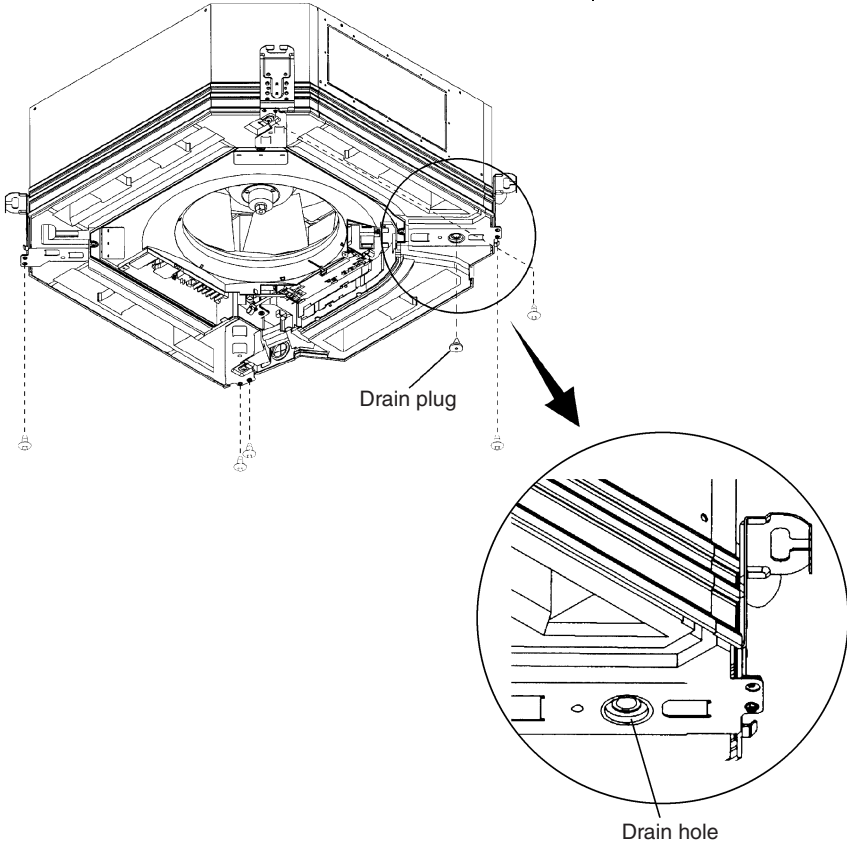

Caution

*If water is in the drain pan, it can spill and wet the floor. Drain water completely or cover the floor with a vinyl sheet.

12.Procedure to Remove Drain Pump and Drain Hose

Procedure



Warning

Be sure to wait for 10 minutes or more after turning off all power supplies before disassembling work.

Step	Procedure	Points
1	Removing the drain pump	
1	Remove the drain pan.	<p>Caution *Be sure to install the pipe clip during installation to prevent water leaks.</p>
2	Remove the hose band.	
3	Pull out the drain hose.	
4	Remove the 4 drain pump mounting screws.	
5	Remove the 3 drain pump mounting plate retaining screws.	
6	Remove the drain pump mounting plate together with the float switch.	

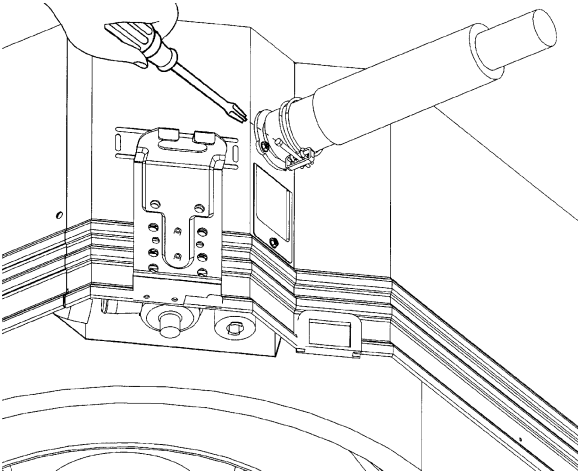
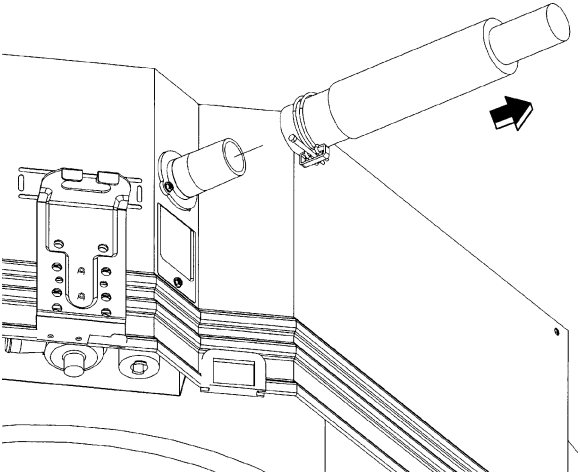
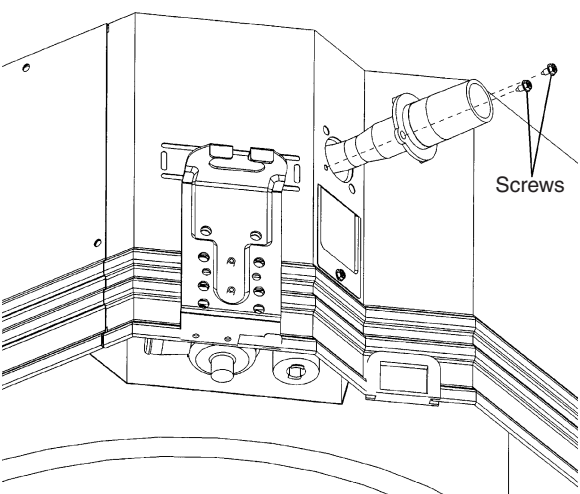
Step	Procedure	Points
2. Removing the drain hose		
1	<p>Loosen the hose band using a screwdriver.</p> 	<p>Caution</p> <p>*The drain hose may contain water. Make sure there is no water in the drain hose, or use a container to receive water from the hose.</p>
2	<p>Pull out the drain hose.</p> 	
3	<p>To remove the drain hose connecting section from the unit, remove the 2 screws and pull it out.</p> 	

Revision History

Month / Year	Version	Revised contents
06 / 2013	Si211306E	First edition

Warning



- Daikin products are manufactured for export to numerous countries throughout the world. Prior to purchase, please confirm with your local authorised importer, distributor and/or retailer whether this product conforms to the applicable standards, and is suitable for use, in the region where the product will be used. This statement does not purport to exclude, restrict or modify the application of any local legislation.
- Ask a qualified installer or contractor to install this product. Do not try to install the product yourself. Improper installation can result in water or refrigerant leakage, electrical shock, fire or explosion.
- Use only those parts and accessories supplied or specified by Daikin. Ask a qualified installer or contractor to install those parts and accessories. Use of unauthorised parts and accessories or improper installation of parts and accessories can result in water or refrigerant leakage, electrical shock, fire or explosion.
- Read the User's Manual carefully before using this product. The User's Manual provides important safety instructions and warnings. Be sure to follow these instructions and warnings.

If you have any enquiries, please contact your local importer, distributor and/or retailer.

Cautions on product corrosion

1. Air conditioners should not be installed in areas where corrosive gases, such as acid gas or alkaline gas, are produced.
2. If the outdoor unit is to be installed close to the sea shore, direct exposure to the sea breeze should be avoided. If you need to install the outdoor unit close to the sea shore, contact your local distributor.



JMI-0107

Organization:
DAIKIN INDUSTRIES, LTD.
AIR CONDITIONING MANUFACTURING DIVISION

Scope of Registration:
THE DESIGN/DEVELOPMENT AND MANUFACTURE OF
COMMERCIAL AIR CONDITIONING, HEATING, COOLING,
REFRIGERATING EQUIPMENT, HEATING EQUIPMENT,
RESIDENTIAL AIR CONDITIONING EQUIPMENT, HEAT
RECLAIM VENTILATION, AIR CLEANING EQUIPMENT,
COMPRESSORS AND VALVES.



JQA-1452

Organization:
DAIKIN INDUSTRIES
(THAILAND) LTD.

Scope of Registration:
THE DESIGN/DEVELOPMENT
AND MANUFACTURE OF AIR
CONDITIONERS AND THE
COMPONENTS INCLUDING
COMPRESSORS USED FOR THEM



EC99J2044

All of the Daikin Group's business facilities and subsidiaries in Japan are certified under the ISO 14001 international standard for environment management.

Dealer

DAIKIN INDUSTRIES, LTD.

Head Office:
Umeda Center Bldg., 2-4-12, Nakazaki-Nishi,
Kita-ku, Osaka, 530-8323 Japan

Tokyo Office:
JR Shinagawa East Bldg., 2-18-1, Konan,
Minato-ku, Tokyo, 108-0075 Japan

http://www.daikin.com/global_ac/

©All rights reserved