



# REMOVAL PROCEDURE



## S E R V I C E M A N U A L

### 11.2/14.0/16.0 kW Class

-  Outdoor Unit
-  Inverter
-  Multi Type

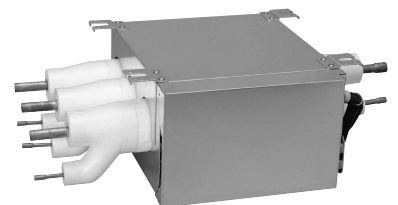

# **Service Manual Removal Procedure**

## **Outdoor Unit**

### **●Cooling Only**

**RMKS112EV1A  
RMKS140EV1A  
RMKS160EV1A**

### **●Heat Pump**

**RMXS112E8V1B  
RMXS140E8V1B  
RMXS160E8V1B**

**RMXS112EVL  
RMXS140EVL  
RMXS160EVL**

**RMXS112EV1A  
RMXS140EV1A  
RMXS160EV1A**

### **●BP Unit**

**BPMKS967A2  
BPMKS967A3**

**BPMKS967B2B  
BPMKS967B3B**

# Table of Contents

1. Outdoor Unit.....	2
1.1 Removal of Outer Panels .....	2
1.2 Removal of PCBs / Electrical Components .....	5
1.3 Removal of Outdoor Fans / Fan Motors .....	12
1.4 Removal of Thermistors .....	14
1.5 Removal of Electronic Expansion Valves / Peripheral Equipments .....	15
1.6 Removal of Four Way Valve.....	19
1.7 Removal of Compressor.....	20
2. BP Unit.....	23
2.1 Removal of PCB Assembly .....	23
2.2 Removal of Electronic Expansion Valve Coils.....	26



**Note:**

- ◆ The illustrations may be slightly different depending on the model.
- ◆ The illustrations are for heat pump models as representative.

# 1. Outdoor Unit

## 1.1 Removal of Outer Panels

**Procedure**



**Warning**

Be sure to wait for 10 minutes or more after turning off all power supplies before disassembling work.

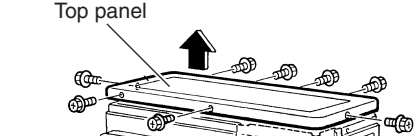
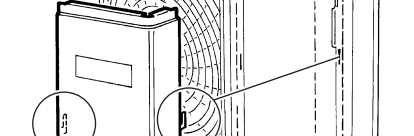
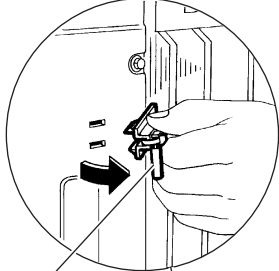
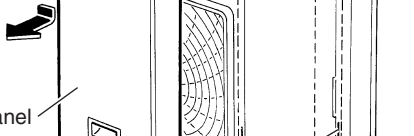
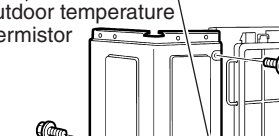
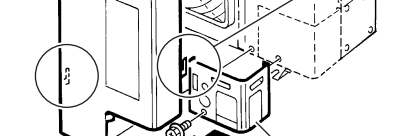
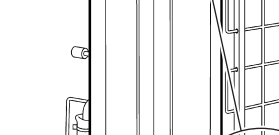
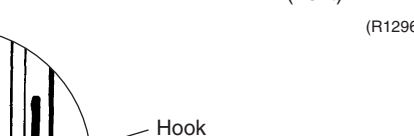
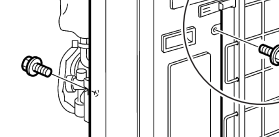
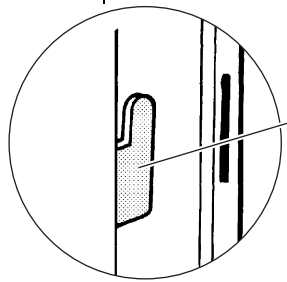
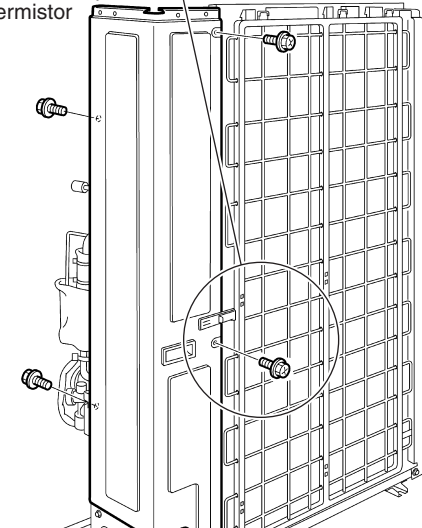
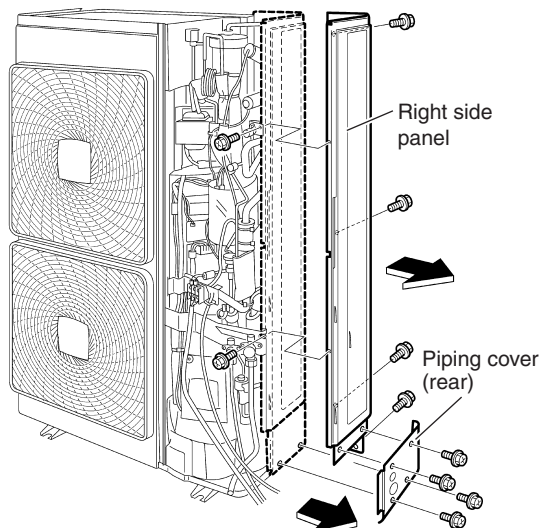
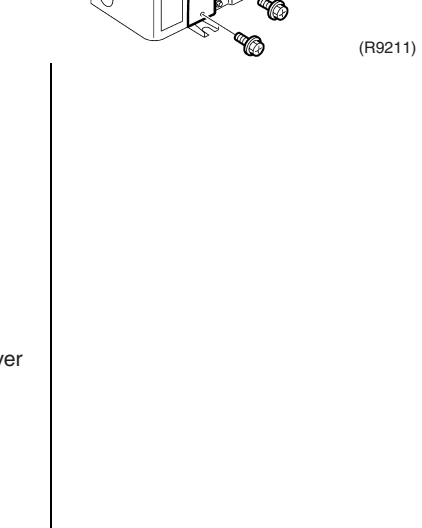
Step	Procedure	Procedure	Points
1	Remove the 8 screws and remove the top panel.		<ul style="list-style-type: none"> <li>It is possible to remove only the front panel (2) without removing the top panel.</li> </ul>
2	Remove the screw of the front panel (2). Push the front panel (2) downward to release the hook and remove it.		
3	Remove the screw and remove the piping cover (front).		
4	Remove the 4 screws and remove the piping cover (rear).		
5	Detach the outdoor temperature thermistor. Remove the 6 screws and remove the right side panel.		
			
			

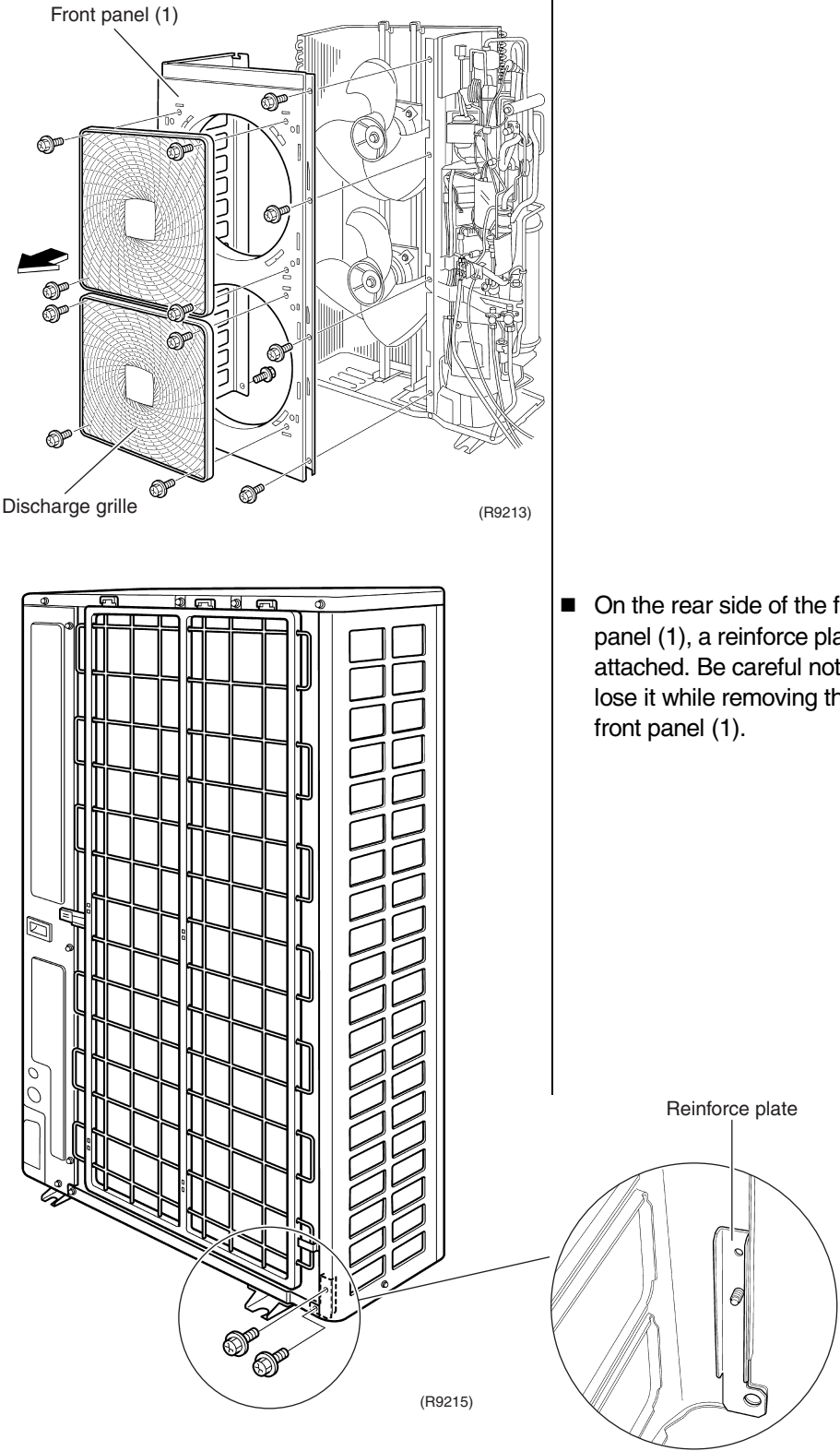
Step	Procedure	Points
<p>6 The outdoor unit has 2 discharge grilles. Remove the 4 screws and unfasten the 4 hooks to remove a discharge grille.</p> <p>7 Remove the 7 screws of the front panel (1). Push the front panel (1) upward and remove it.</p>	 <p>Front panel (1)</p> <p>Discharge grille</p> <p>(R9213)</p> <p>(R9215)</p> <p>Reinforce plate</p>	<ul style="list-style-type: none"> <li>■ On the rear side of the front panel (1), a reinforce plate is attached. Be careful not to lose it while removing the front panel (1).</li> </ul>

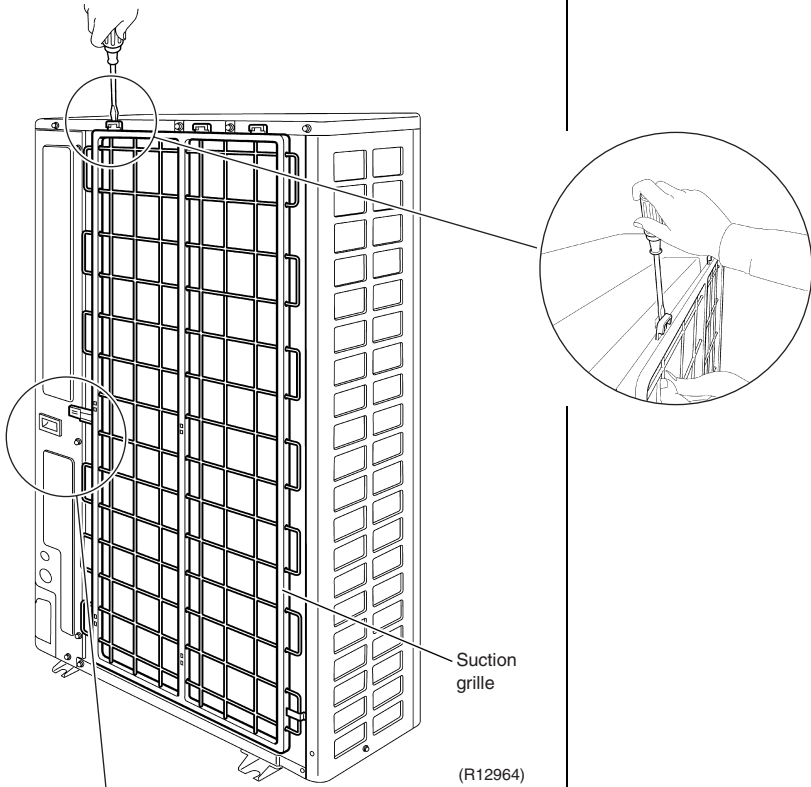
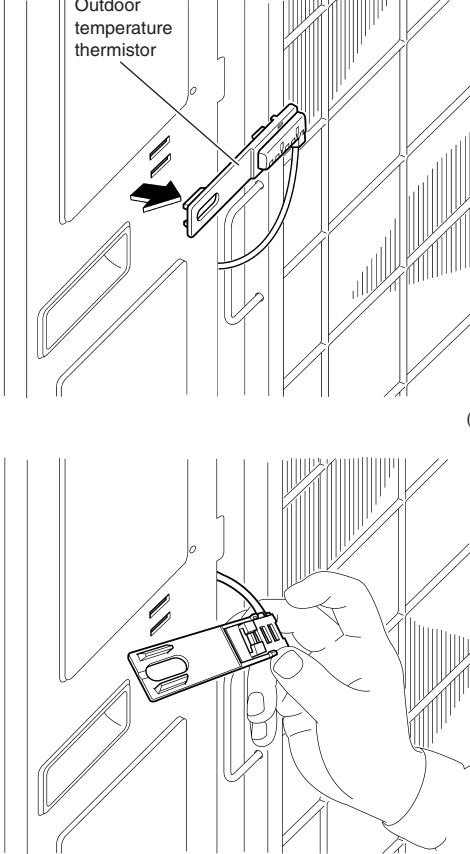
Step	Procedure	Points
<p>8 Unfasten the 3 hooks with a flat screwdriver and remove the suction grille.</p>	 <p>Suction grille</p> <p>(R12964)</p>	
<p>9 Pull the outdoor temperature thermistor and slide it to the right. Detach the outdoor temperature thermistor.</p>	 <p>Outdoor temperature thermistor</p> <p>(R12965)</p> <p>(R9218)</p>	



## 1.2 Removal of PCBs / Electrical Components

### Procedure

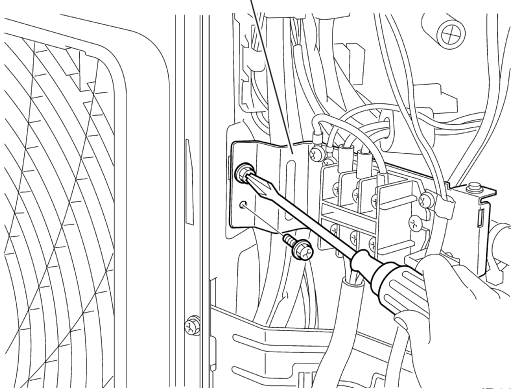

### Warning

Be sure to wait for 10 minutes or more after turning off all power supplies before disassembling work.

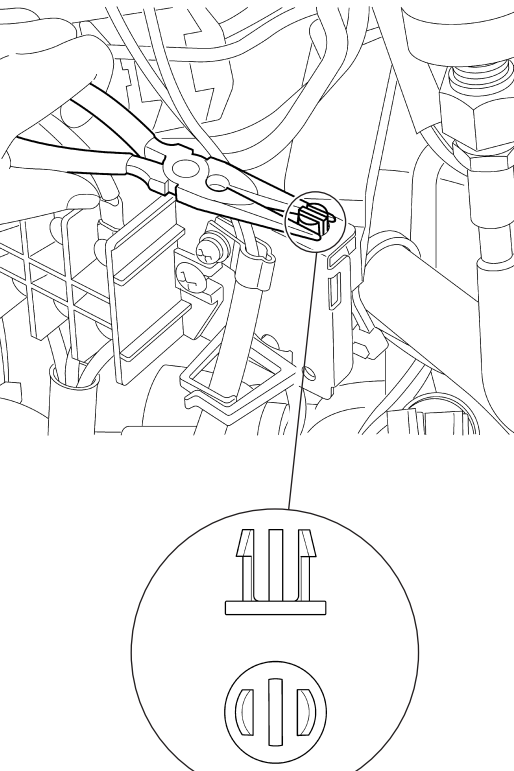
Step	Procedure	Procedure	Points
1	Remove the 2 screws of the terminal mounting plate.	 <p style="text-align: right;">(R12966)</p>	<b>Preparation</b> <ul style="list-style-type: none"> <li>■ Remove the outer panels according to the "Removal of Outer Panels".</li> <li>■ M5(3) × 12</li> </ul>
2	Remove the screw above the electrical component assembly.	 <p style="text-align: right;">(R9220)</p>	<ul style="list-style-type: none"> <li>■ M5(3) × 12</li> </ul>
3	Unfasten the clamp from the terminal mounting plate.	 <p style="text-align: right;">(R9221)</p>	

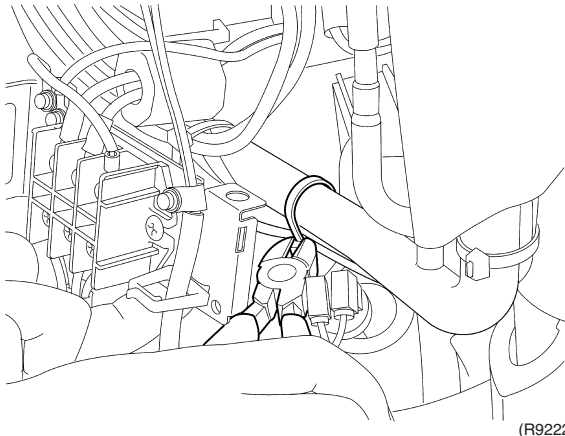
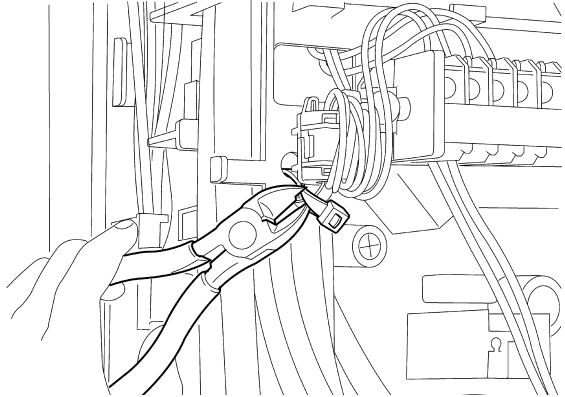
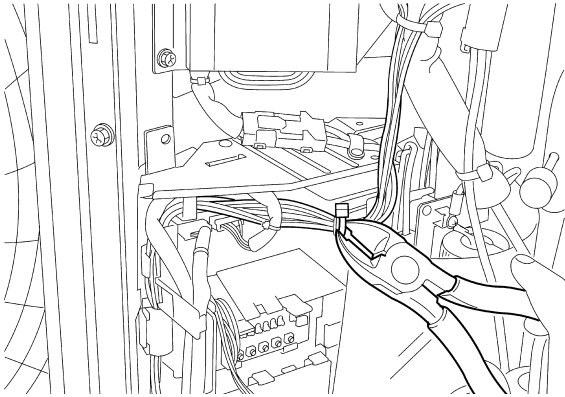
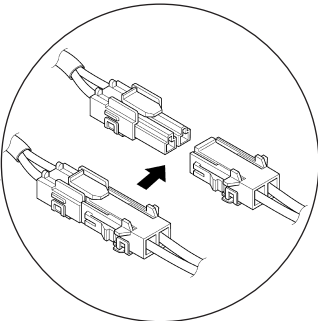
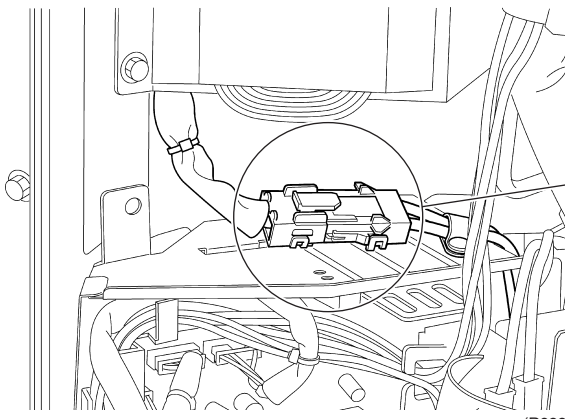
Step	Procedure	Points
4	Cut off the 3 clamps.	
	 <p>(R9222)</p>	
	 <p>(R9223)</p>	
	 <p>(R9224)</p>	
5	Disconnect the relay connector for the reactor lead wire from each other.	
	 <p>(R9225)</p>	

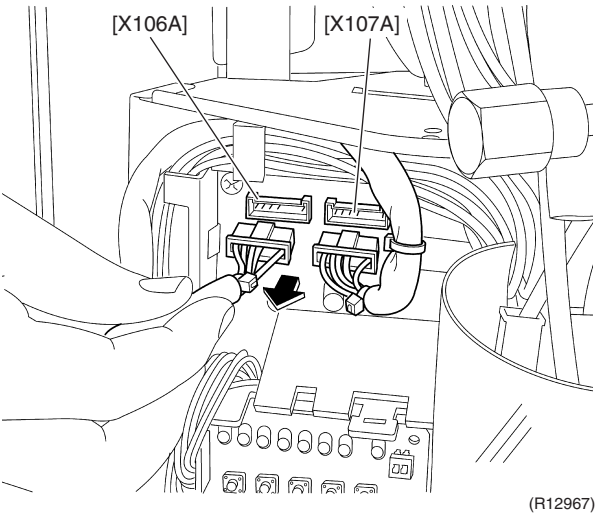
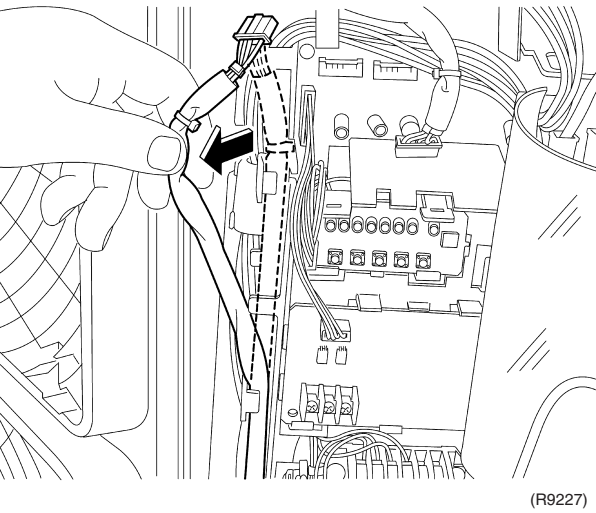
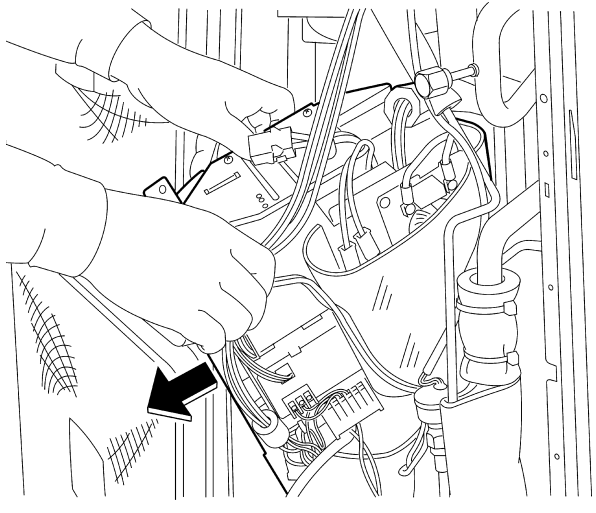

Step	Procedure	Points
6	Disconnect the 2 connectors for the fan motor [X106A] [X107A].	
	 <p>(R12967)</p>	
7	Release the fan motor lead wires from the hooks.	
	 <p>(R9227)</p>	
8	Release the lead wires of the solenoid valves and four way valve from the fixing plate and then remove the electrical component assembly.	
	 <p>(R9228)</p>	

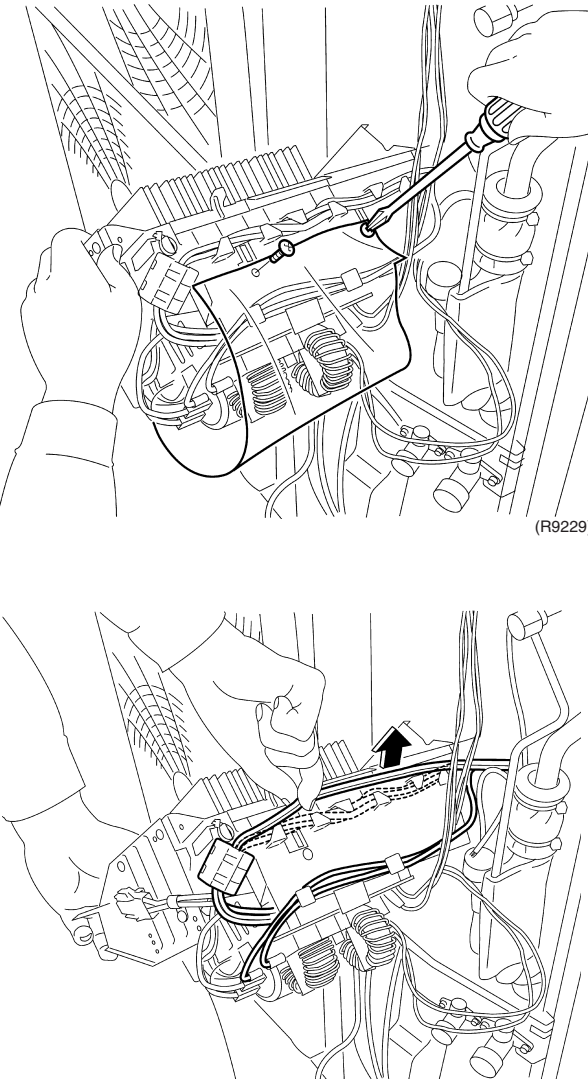
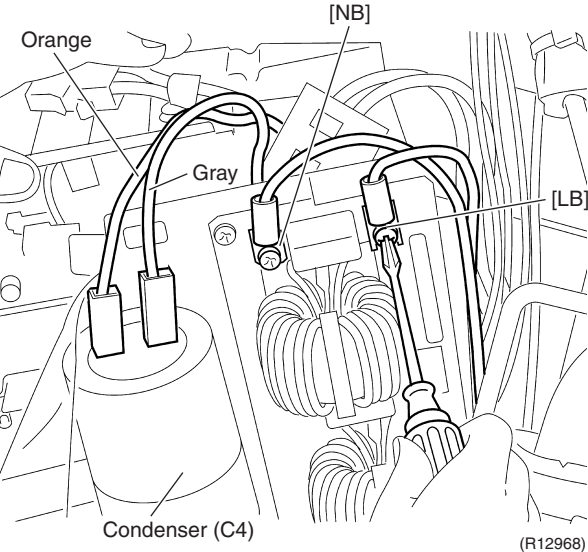
Step	Procedure	Procedure	Points
<p>9</p>	<p>Remove the 2 screws of the insulation sheet and then release the compressor lead wires (blue, red, white) and the lead wires between A1P and A3P (red, blue) from the hooks.</p>	 <p>(R9229)</p> <p>(R9230)</p>	
<p>10</p>	<p>Remove the 2 screws from [LB] (red) and [NB] (blue) on A3P and disconnect the 2 lead wires of condenser (orange, gray).</p>	 <p>(R12968)</p>	<p>■ M4 × 8 with spring washer</p>

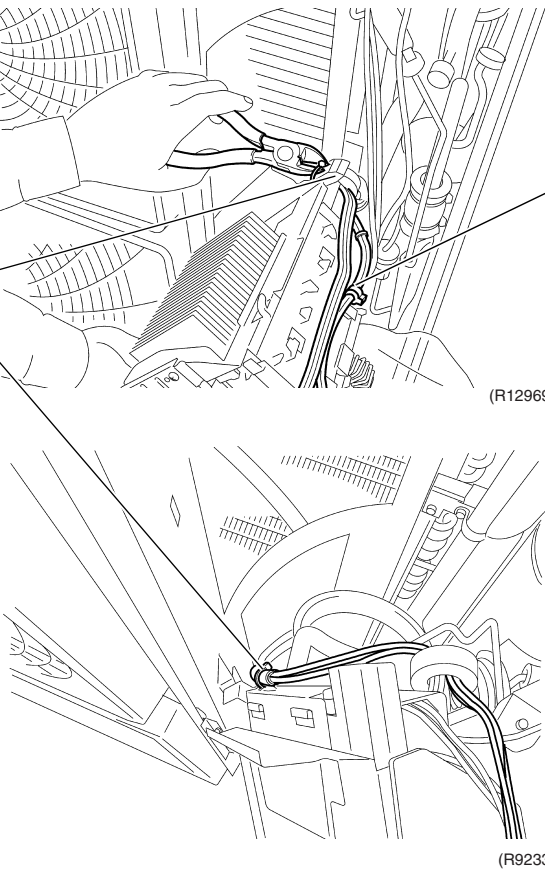
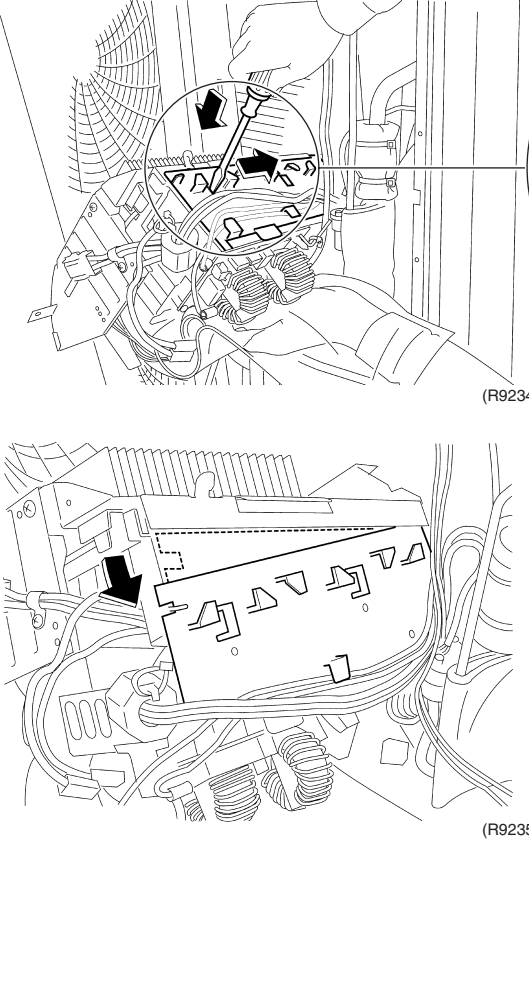
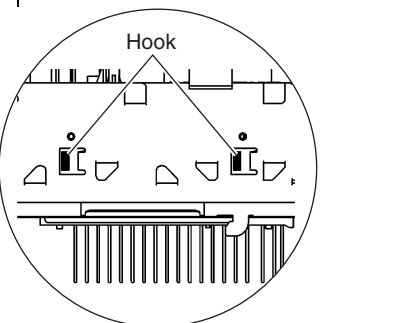
Step	Procedure	Points
<p>11</p> <p>Cut the 2 clamps, for the compressor lead wires.</p> <p>Cut the clamp for the lead wires from A3P to A1P (red, blue) and for the earth (green).</p> <p>Clamps (2 places) for the compressor lead wires</p>	 <p>(R12969)</p> <p>(R9233)</p>	<p>Clamp for the lead wires from A3P to A1P and for the earth</p>
<p>12</p> <p>Push and unfasten the 2 hooks and slide the casing to the right and remove the casing from the electrical component assembly.</p>	 <p>(R9234)</p> <p>(R9235)</p>	 <p>Hook</p>

Step	Procedure	Points
13	<p>Disconnect the connectors [X66A] [X81A] [X5A].</p>	<p>[X66A] [X81A] [X5A] (R12970)</p>
14	<p>Disconnect the reactor lead wire connectors, compressor lead wire connector, and all the other connectors from the main PCB. [X22A] [X21A] [X13A] [X11A] [X12A] [X18A] [X17A] [X32A] [X25A] [X26A] [X27A] [X28A]</p>	<p>Compressor lead wire connector</p> <p>Reactor lead wire connectors</p> <p>(R12971)</p>

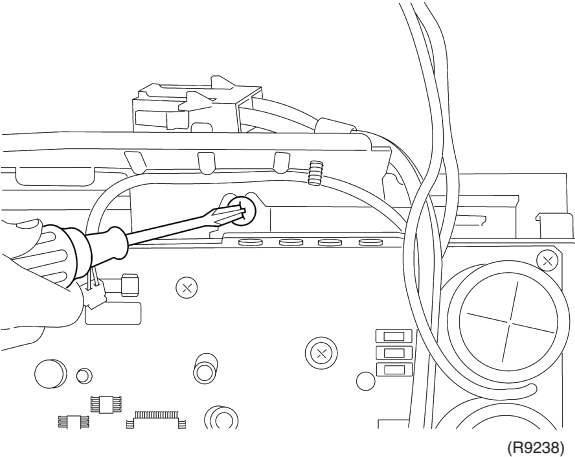
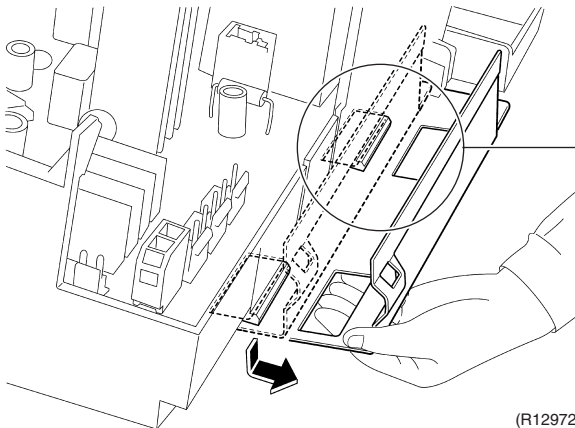
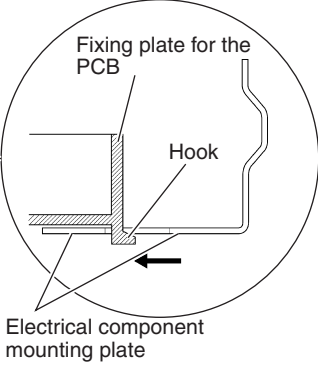
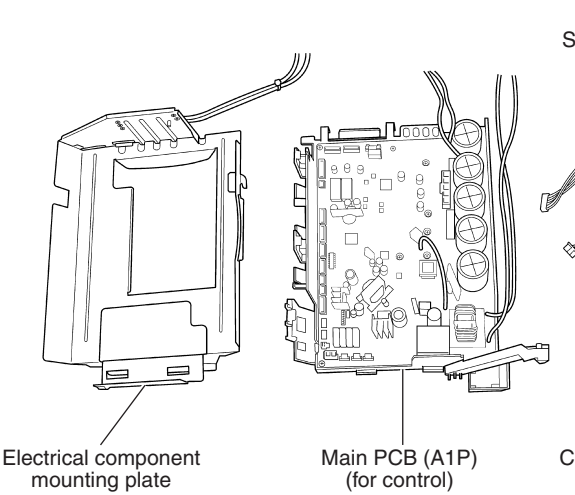
Step	Procedure	Procedure	Points
15	Remove the screw at the top of the electrical component assembly.		<p>■ M4(2) × 12</p>
16	Unfasten the 2 hooks at the rear side.		
17	The figures in the right are PCB assembly.		<p>Service PCB (A2P)</p> <p>Noise filter PCB (A3P)</p> <p>Cool / heat selector PCB (A4P)</p>

# 1.3 Removal of Outdoor Fans / Fan Motors

**Procedure**

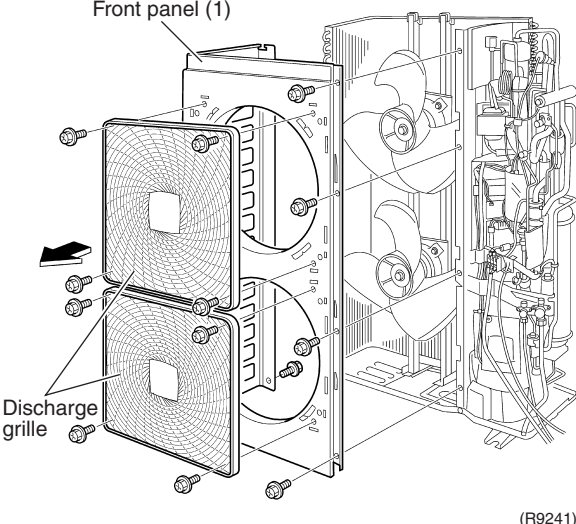
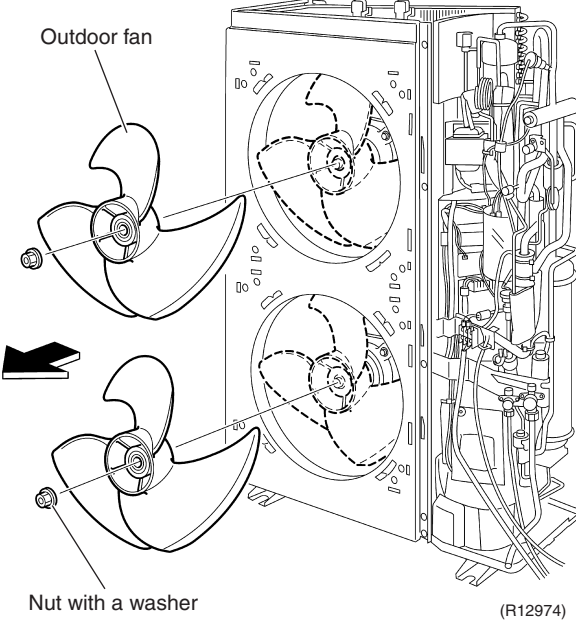
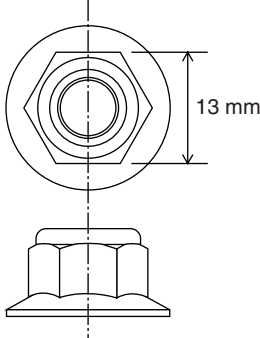

**Warning** Be sure to wait for 10 minutes or more after turning off all power supplies before disassembling work.

Step	Procedure	Points
<p>1</p>	<p>Remove the nuts which fixing the outdoor fan.</p>  	<p><b>Preparation</b></p> <ul style="list-style-type: none"> <li>Remove the discharge grille, front panels (1) and (2), and piping cover (front), according to the "Removal of Outer Panels".</li> </ul> <p>■ Nut size : M8</p>  <ul style="list-style-type: none"> <li>When reassembling, align the ▼ mark of the outdoor fan with the D-cut section of the motor shaft.</li> </ul>

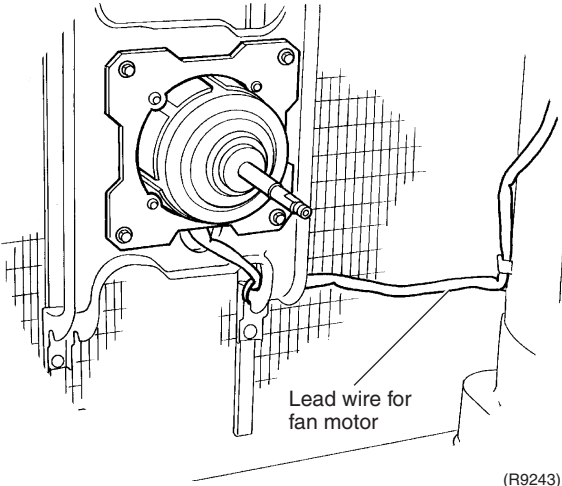
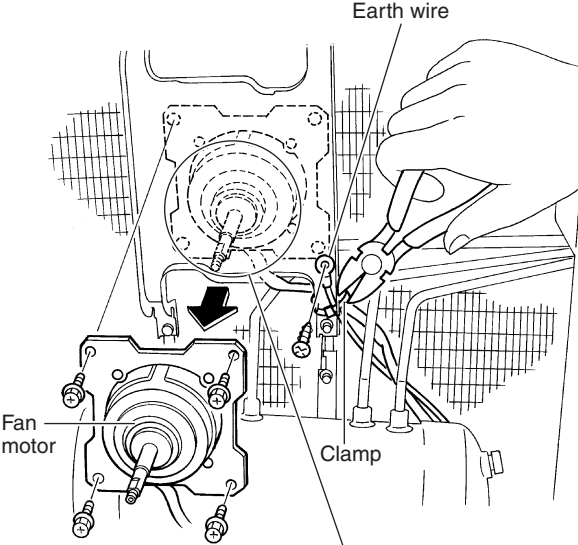
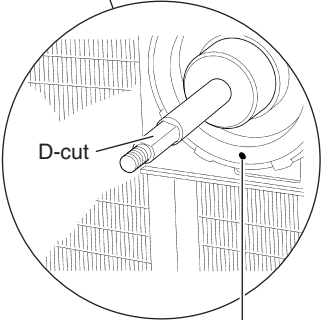
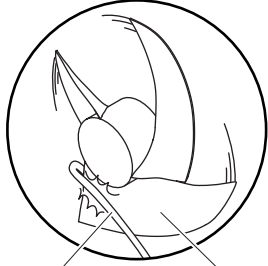
Step	Procedure	Points
<p>2 Cut the clamp.</p> <p>3 Remove the 4 screws and remove the fan motor.</p>	 <p style="text-align: right;">(R9243)</p>   <p style="text-align: center;">Mount the fan motor with its mark "●" positioned toward the bottom.</p> <p style="text-align: right;">(R9244)</p>	<ul style="list-style-type: none"> <li>■ Pull out the connector while supporting the fan motor and pushing the engaging hook, without pulling its lead wires.</li> <li>■ When reassembling, put the fan motor lead wire through the back of the fan motor (so as not to be entangled with the outdoor fan).</li> </ul>  <p style="text-align: center;">(R3249)</p> <ul style="list-style-type: none"> <li>■ Be sure to remove the lower screws first. If the upper screws are removed first, the fan motor, the center of gravity of which is toward the front, may tilt down or fall, getting you injured.</li> </ul>

# 1.4 Removal of Thermistors

**Procedure**



**Warning** Be sure to wait for 10 minutes or more after turning off all power supplies before disassembling work.

Step	Procedure	Points
<p>1 For the details of the removal of the outdoor temperature thermistor (R1T), see the points on the right column.</p> <p>2 Pull out the discharge pipe thermistor (R2T).</p>	<p>Subcooling thermistor (R6T)</p> <p>Suction pipe thermistor 1 (R3T)</p> <p>Suction pipe thermistor 2 (R5T)</p> <p>Discharge pipe thermistor (R2T)</p>	<p><b>Preparation</b></p> <ul style="list-style-type: none"> <li>Remove the front panel (2) and the right side panel according to the "Removal of Outer Panels".</li> <li>Removal of the outdoor temperature thermistor (R1T)</li> </ul> <p>Hooks (2 places) Right side panel</p> <p>Notch</p> <p>Fixing plate for thermistor (R1T)</p> <p>Removal direction Stopper</p> <p>Outdoor temperature thermistor</p> <p>Marking (yellow) (R13061)</p>
<p>3 Pull out the suction pipe thermistors (R3T) (R5T).</p>		
<p>4 Pull out the subcooling thermistor (R6T) and the liquid pipe thermistor (R7T).</p>	<p>Liquid pipe thermistor (R7T)</p>	
<p>5 Pull out the outdoor heat exchanger thermistor (R4T).</p>	<p>Outdoor heat exchanger thermistor (R4T) (R12975)</p>	
		<ul style="list-style-type: none"> <li>When reassembling, pass the outdoor temperature thermistor through the hole of the tube plate so as the yellow marking comes to the inside edge of the tube plate.</li> </ul>



# 1.5 Removal of Electronic Expansion Valves / Peripheral Equipments

## Procedure



### Warning

Be sure to wait for 10 minutes or more after turning off all power supplies before disassembling work.

Step	Procedure	Procedure	Points
1	Pull out the 2 electronic expansion valve coils.	<p>Electronic expansion valve coil (main) (Y1E)</p> <p>Electronic expansion valve coil (subcooling) (Y3E)</p> <p>(R12996)</p> <p>(R9252)</p>	
2	Remove the 2 pressure sensors.	<p>High pressure sensor (S1NPH)</p> <p>(R12976)</p> <p>Low pressure sensor (S1NPL)</p> <p>(R12977)</p>	<ul style="list-style-type: none"> <li>■ When removing the pressure sensor, be sure to use 2 wrench as the left figure shows.</li> <li>■ The pressure sensor is equipped with a gauge port with check valve. Therefore, when loosening the nut, refrigerant leak stops.</li> </ul>

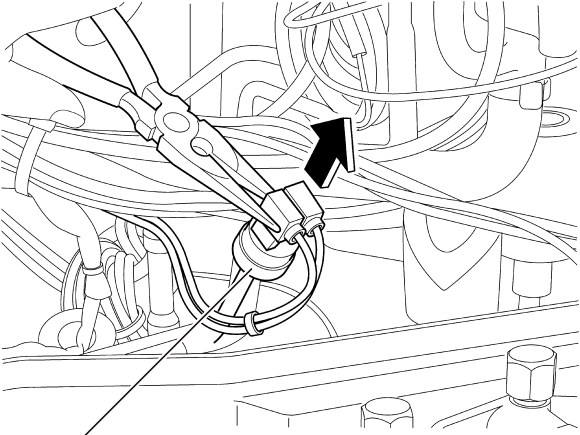
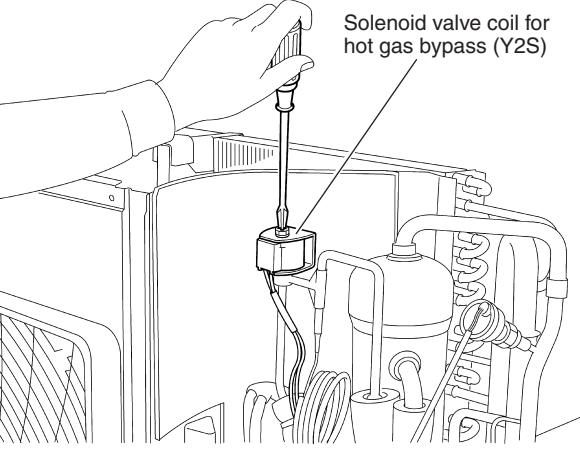
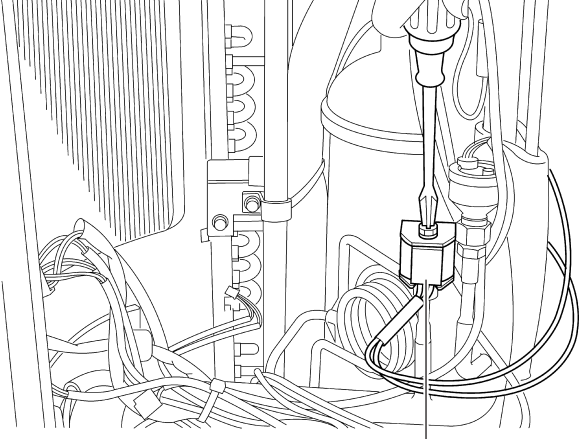
Step	Procedure	Points
3	<p>Disconnect the lead wires of the high pressure switch.</p>  <p>High pressure switch (S1PH)</p> <p>(R12978)</p>	
4	<p>Remove the screw and remove the solenoid valve coil for hot gas bypass.</p>  <p>Solenoid valve coil for hot gas bypass (Y2S)</p> <p>(R12979)</p>	
5	<p>Remove the screw and remove the solenoid valve coil for unloading.</p>  <p>Solenoid valve coil for unloading (Y3S)</p> <p>(R12980)</p>	

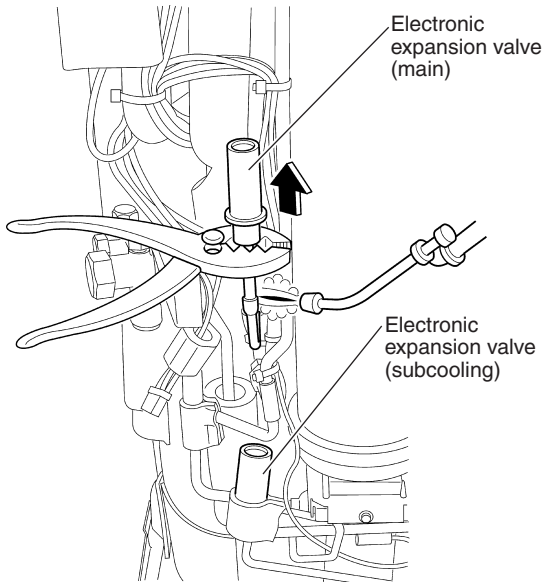
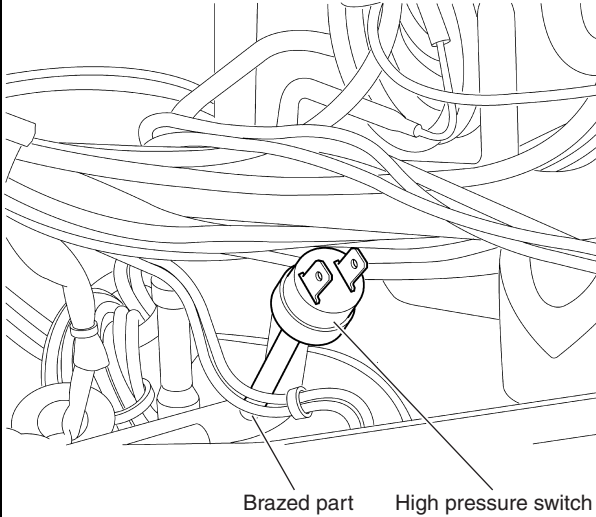
Step	Procedure	Points
<ul style="list-style-type: none"> <li>■ Before working, make sure that the refrigerant gas is empty in the circuit.</li> <li>■ Be sure to apply nitrogen replacement when heating up the brazed part.</li> </ul>		<p><b>Warning</b> Be careful not to get yourself burnt with the pipes and other parts that are heated by the gas brazing machine.</p>
6	<p>Disconnect the brazed part of the electronic expansion valve.</p>	<p><b>Warning</b> If the refrigerant gas leaks during work, ventilate the room. (If the refrigerant gas is exposed to flames, toxic gas may be generated.)</p> <p><b>Caution</b> From the viewpoint of global environment protection, do not discharge the refrigerant gas in the atmosphere. Make sure to collect all the refrigerant gas.</p>
7	<p>Disconnect the brazed part of the high pressure switch.</p> 	<p><b>Cautions for restoration</b></p> <ol style="list-style-type: none"> <li>1. Restore the piping by non-oxidation brazing.</li> <li>2. It is required to prevent the carbonization of the oil inside the four way valve and the deterioration of the gaskets affected by heat. (Keep below 120°C.) For the sake of this, wrap the four way valve with wet cloth and provide water so that the cloth does not dry.</li> </ol> <p><b>In case of difficulty with gas brazing machine</b></p> <ol style="list-style-type: none"> <li>1. Disconnect the brazed part where is easy to disconnect and restore.</li> <li>2. Cut pipes on the main unit with a tube cutter in order to make it easy to disconnect.</li> </ol>

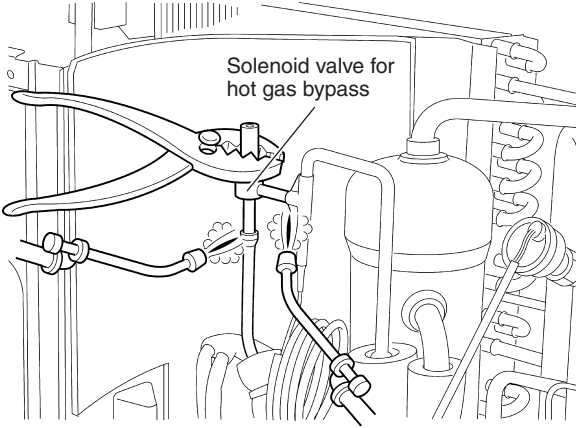
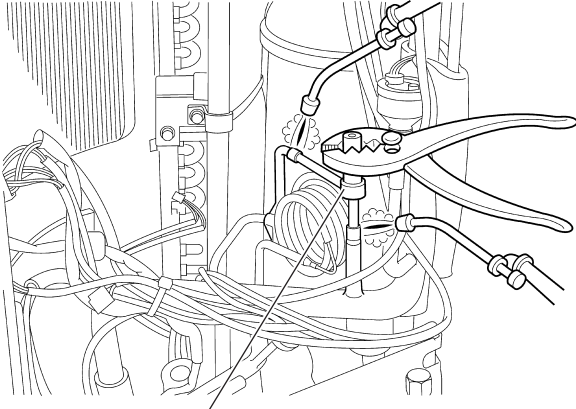
Step	Procedure	Points
<p>8</p>	<p>Disconnect the brazed part of the solenoid valve.</p>  <p>Solenoid valve for hot gas bypass</p> <p>(R12983)</p>  <p>Solenoid valve for unloading</p> <p>(R12984)</p>	<p><b>Note:</b></p> <ul style="list-style-type: none"> <li>■ Do not use a metal saw for cutting pipes by all means because the sawdust comes into the circuit.</li> <li>■ When withdrawing the pipes, be careful not to pinch them firmly with pliers. The pipes may get deformed.</li> <li>■ Provide a protective sheet or a steel plate so that the brazing flame cannot influence peripheries.</li> </ul>

## 1.6 Removal of Four Way Valve

### Procedure

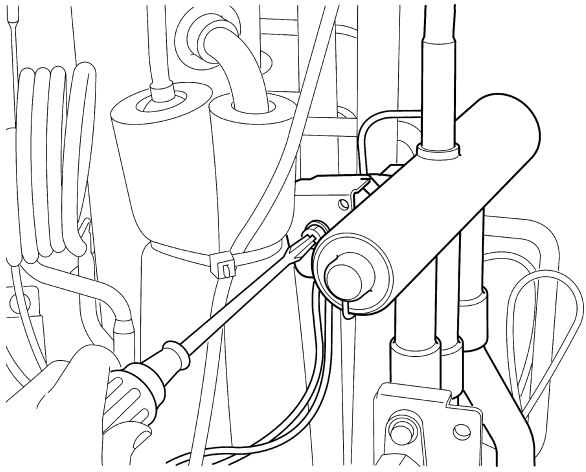
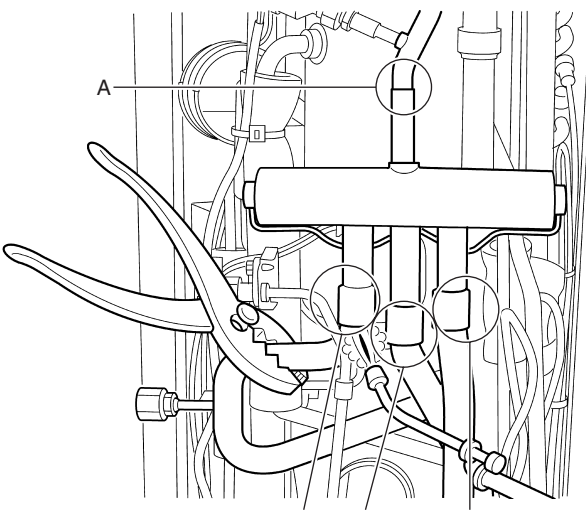

**Warning** Be sure to wait for 10 minutes or more after turning off all power supplies before disassembling work.

Step	Procedure	Procedure	Points
1	Remove the screw and remove the four way valve coil.	 <p style="text-align: right;">(R9262)</p>	<p><b>Warning</b> Be careful not to get yourself burnt with the pipes and other parts that are heated by the gas brazing machine.</p> <p><b>Warning</b> If the refrigerant gas leaks during work, ventilate the room. (If the refrigerant gas is exposed to flames, toxic gas may be generated.)</p> <p><b>Caution</b> From the viewpoint of global environment protection, do not discharge the refrigerant gas in the atmosphere. Make sure to collect all the refrigerant gas.</p>
<ul style="list-style-type: none"> <li>■ Before working, make sure that the refrigerant gas is empty in the circuit.</li> <li>■ Be sure to apply nitrogen replacement when heating up the brazed part.</li> </ul>			
2	Disconnect the brazed part of the four way valve (A, B, C, D).	 <p style="text-align: right;">(R9263)</p>	<p><b>Cautions for restoration</b></p> <ol style="list-style-type: none"> <li>1. Restore the piping by non-oxidation brazing.</li> <li>2. It is required to prevent the carbonization of the oil inside the four way valve and the deterioration of the gaskets affected by heat. (Keep below 120°C.) For the sake of this, wrap the four way valve with wet cloth and provide water so that the cloth does not dry.</li> </ol> <p><b>In case of difficulty with gas brazing machine</b></p> <ol style="list-style-type: none"> <li>1. Disconnect the brazed part where is easy to disconnect and restore.</li> <li>2. Cut pipes on the main unit with a tube cutter in order to make it easy to disconnect.</li> </ol>
<p><b>Note:</b></p> <ul style="list-style-type: none"> <li>■ Do not use a metal saw for cutting pipes by all means because the sawdust comes into the circuit.</li> <li>■ When withdrawing the pipes, be careful not to pinch them firmly with pliers. The pipes may get deformed.</li> <li>■ Provide a protective sheet or a steel plate so that the brazing flame cannot influence peripheries.</li> </ul>			

# 1.7 Removal of Compressor

**Procedure**



**Warning**

Be sure to wait for 10 minutes or more after turning off all power supplies before disassembling work.

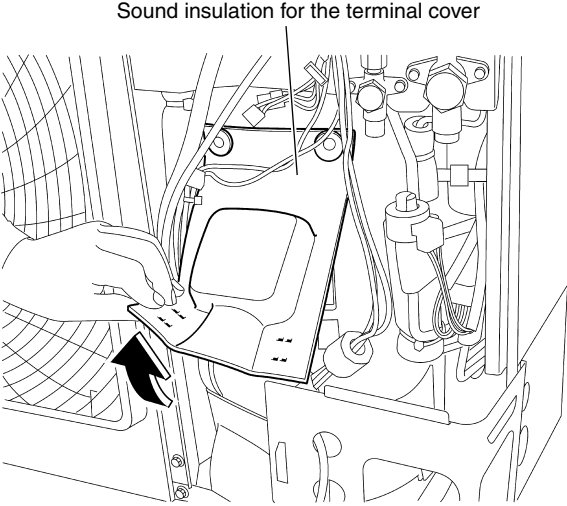
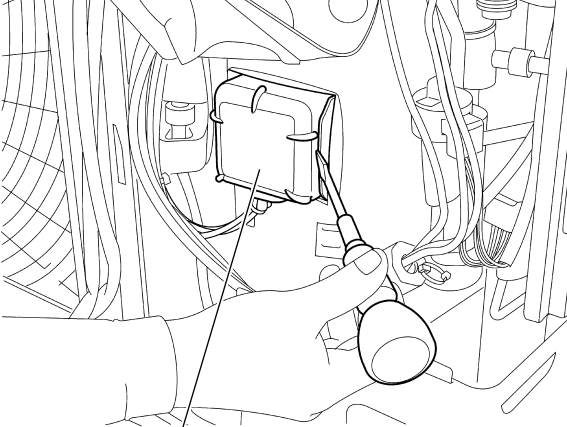
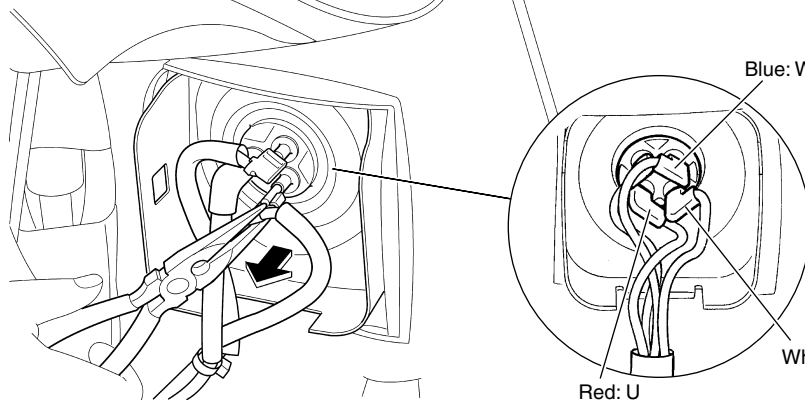
Step	Procedure	Procedure	Points
1	Open upward the sound insulation for the terminal cover.	 <p style="text-align: right;">(R9264)</p>	<p><b>Preparation</b></p> <ul style="list-style-type: none"> <li>Remove the outer panels, electrical components, and peripheral equipments.</li> </ul>
2	Remove the terminal cover with a flat screwdriver.	 <p style="text-align: right;">(R9265)</p>	
3	Disconnect the terminals of the compressor.	 <p style="text-align: right;">(R12985)</p>	

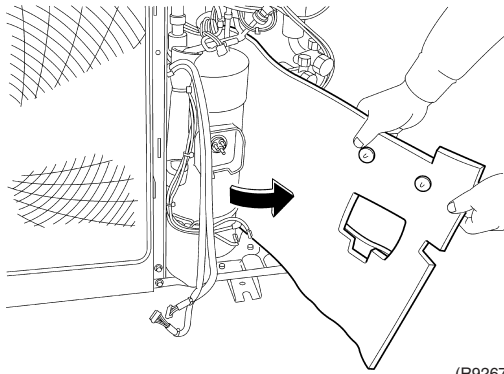
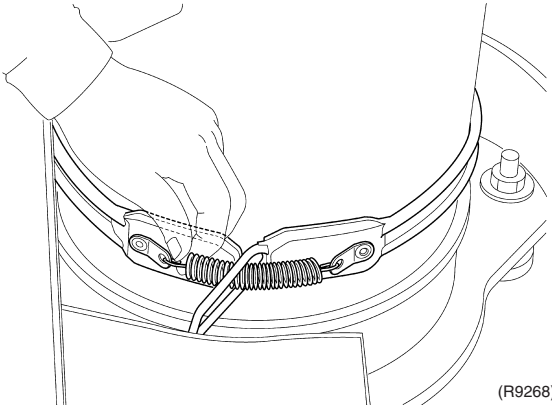
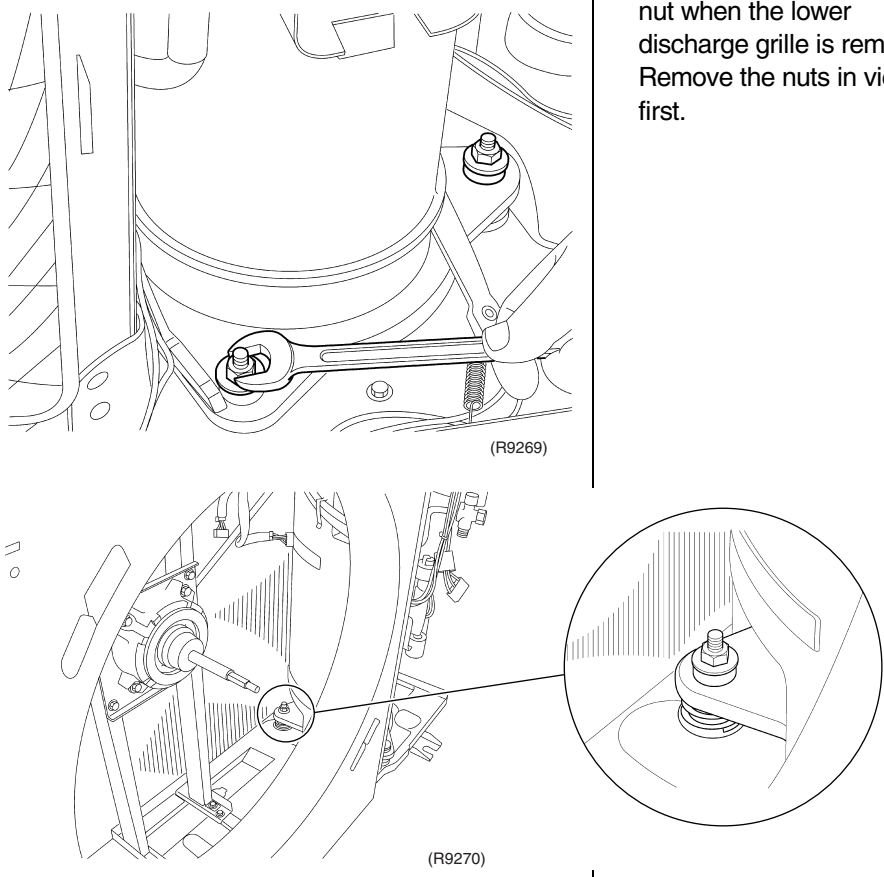
Step	Procedure	Points
4	<p>Remove the sound insulation for the compressor.</p>  <p>(R9267)</p>	
5	<p>Remove the crankcase heater at the lower of the compressor.</p>  <p>(R9268)</p>	<ul style="list-style-type: none"> <li>■ Pull the spring to release the catch.</li> </ul>
6	<p>Remove the 3 nuts of the compressor.</p>  <p>(R9269)</p> <p>(R9270)</p>	<ul style="list-style-type: none"> <li>■ You can see the rear side nut when the lower discharge grille is removed. Remove the nuts in view first.</li> </ul>

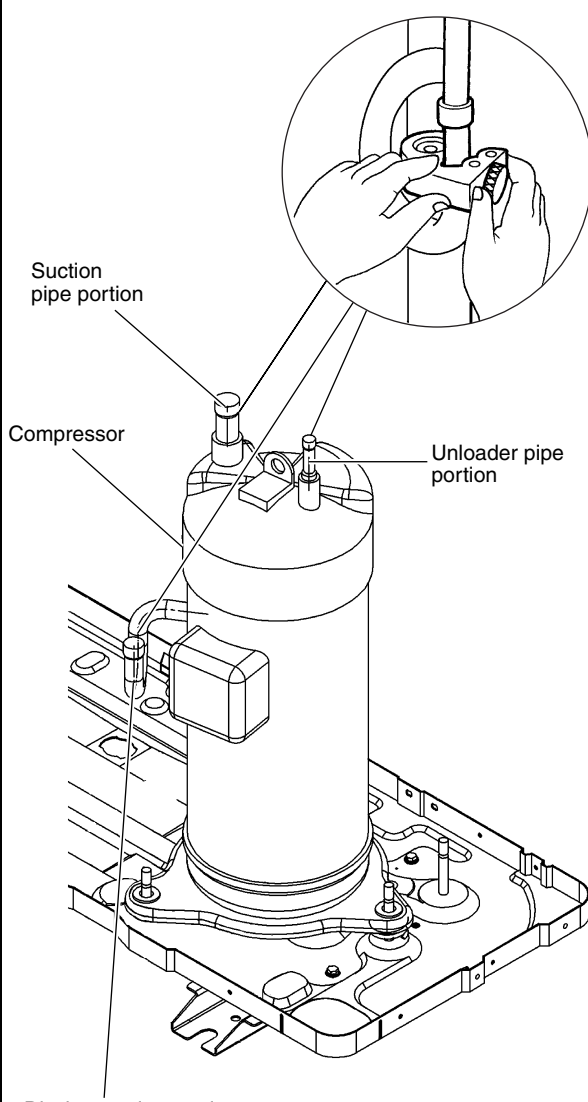
Step	Procedure	Points
<ul style="list-style-type: none"> <li>■ Before working, make sure that the refrigerant gas is empty in the circuit.</li> <li>■ Be sure to apply nitrogen replacement when heating up the brazed part.</li> </ul>		
<p>7</p>	<p>Cut off the suction pipe, discharge pipe and unloader pipe of compressor with a pipe cutter (3 places).</p>	<p><b>Warning</b> Be careful not to get yourself burnt with the pipes and other parts that are heated by the gas brazing machine.</p>
<p>8</p>	<p>Remove the compressor.</p>	<p><b>Warning</b> If the refrigerant gas leaks during work, ventilate the room. (If the refrigerant gas is exposed to flames, toxic gas may be generated.)</p>
<p>9</p>	<p>Disconnect the brazed parts and remove the remained pipes.</p>	<p><b>Warning</b> Since it may happen that the refrigerant oil in the compressor catches fire, prepare wet cloth so as to extinguish fire immediately.</p> <p><b>Caution</b> From the viewpoint of global environment protection, do not discharge the refrigerant gas in the atmosphere. Make sure to collect all the refrigerant gas.</p> <p><b>Cautions for restoration</b></p> <ol style="list-style-type: none"> <li>1. Restore the piping by non-oxidation brazing.</li> <li>2. It is required to prevent the carbonization of the oil inside the four way valve and the deterioration of the gaskets affected by heat. (Keep below 120°C.) For the sake of this, wrap the four way valve with wet cloth and provide water so that the cloth does not dry.</li> </ol>
<p><b>Note:</b></p> <ul style="list-style-type: none"> <li>■ Do not use a metal saw for cutting pipes by all means because the sawdust comes into the circuit.</li> <li>■ When withdrawing the pipes, be careful not to pinch them firmly with pliers. The pipes may get deformed.</li> <li>■ Provide a protective sheet or a steel plate so that the brazing flame cannot influence peripheries.</li> <li>■ Be careful so as not to burn the compressor terminals, the name plate, the heat exchanger fin.</li> </ul>	 <p style="text-align: right;">(R12986)</p>	<p><b>In case of difficulty with gas brazing machine</b></p> <ol style="list-style-type: none"> <li>1. Disconnect the brazed part where is easy to disconnect and restore.</li> <li>2. Cut pipes on the main unit with a tube cutter in order to make it easy to disconnect.</li> </ol>



## 2. BP Unit

### 2.1 Removal of PCB Assembly

**Procedure**



**Warning**

Be sure to wait for 10 minutes or more after turning off all power supplies before disassembling work.

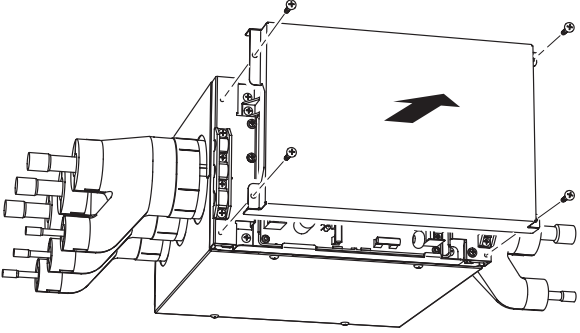
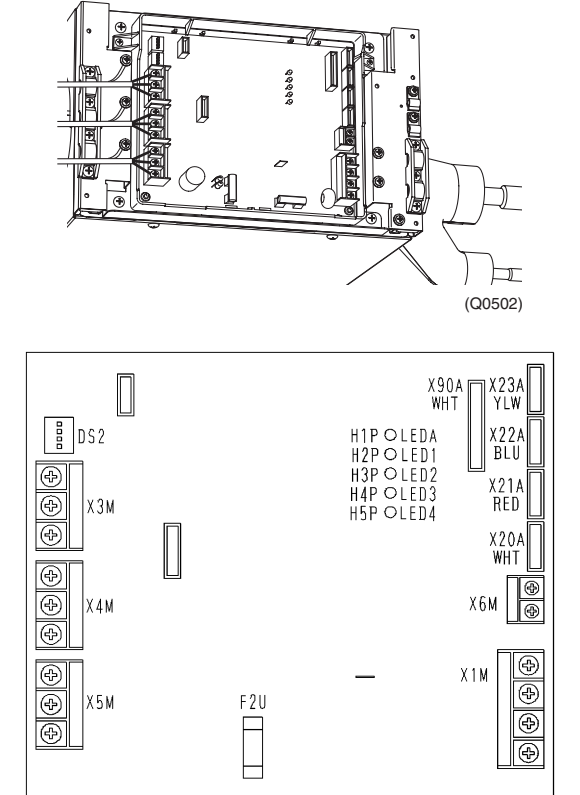
Step	Procedure	Procedure	Points
1	Remove the 4 screws and remove the electrical box cover.	 <p style="text-align: right;">(Q0501)</p>	
2	The PCB is as shown at the right. Disconnect all the relay cables.	 <p style="text-align: right;">(Q0502)</p> <p style="text-align: right;">(R12987)</p>	<ul style="list-style-type: none"> <li>■ The PCB is waterproof with resin. This means that the fuse and varistor cannot be replaced.</li> </ul> <p>When reassembling, have test operation for checking wrong wiring.</p>

Step	Procedure	Points
3	<p>Disconnect the connectors for the electronic expansion valve [X20A] [X21A] [X22A] [X23A] and the connector for the thermistors [X90A].</p>	<ul style="list-style-type: none"> <li>■ [X20A]: bypass</li> <li>[X21A]: for room A</li> <li>[X22A]: for room B</li> <li>[X23A]: for room C</li> </ul>
4	<p>Remove the screw of the wire harness band.</p>	
5	<p>Remove the screw of the earth wire.</p>	

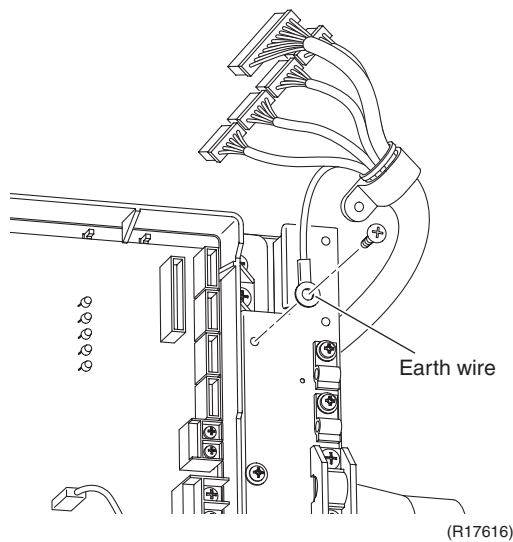
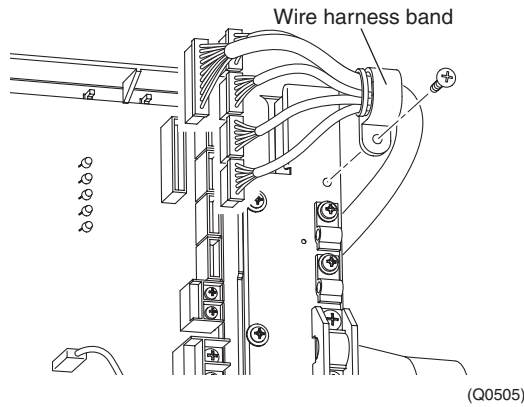
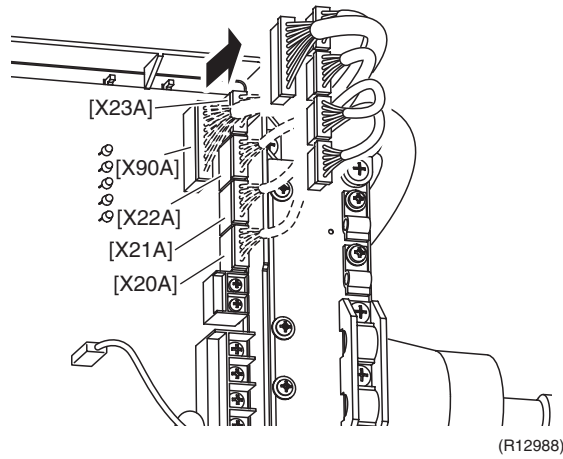

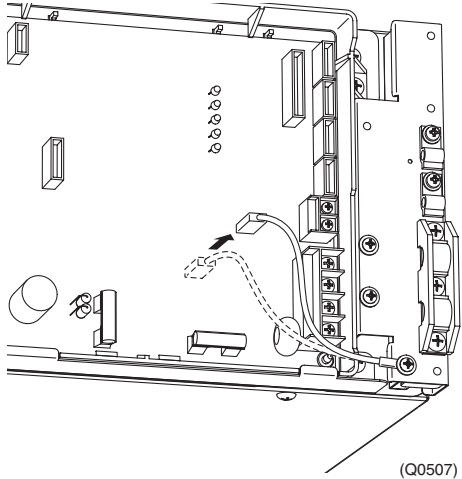
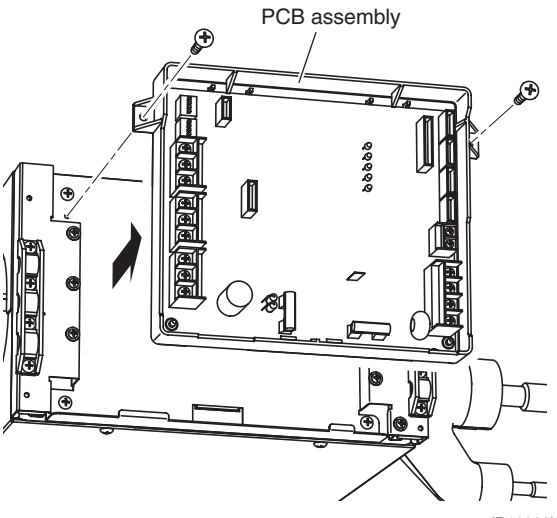
Step	Procedure	Points
6	<p>Disconnect the terminal of the earth wire.</p>  <p>(Q0507)</p>	
7	<p>Remove the 2 screws and remove the PCB assembly.</p>  <p>PCB assembly</p> <p>(R12990)</p>	

## 2.2 Removal of Electronic Expansion Valve Coils

**Procedure**



**Warning**

Be sure to wait for 10 minutes or more after turning off all power supplies before disassembling work.

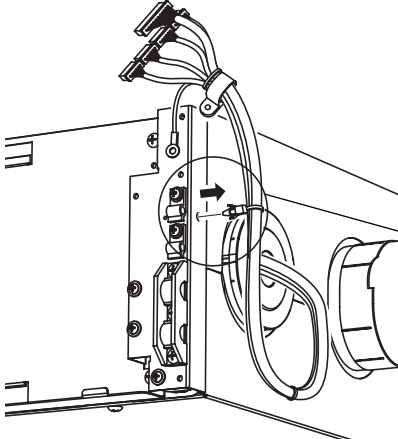
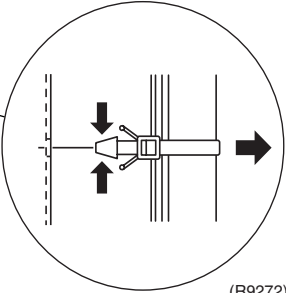
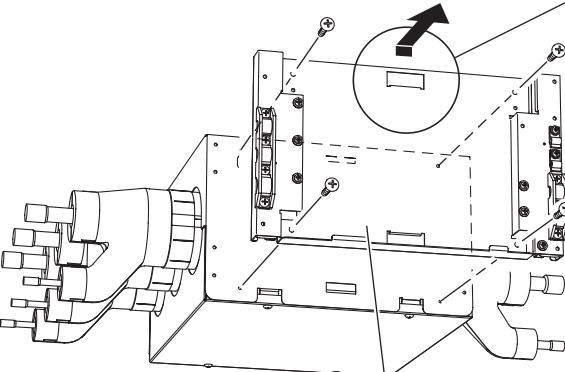
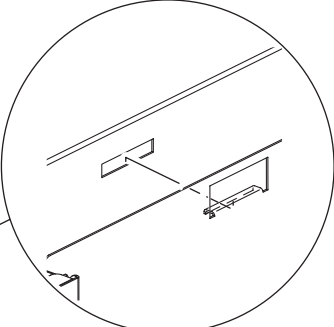
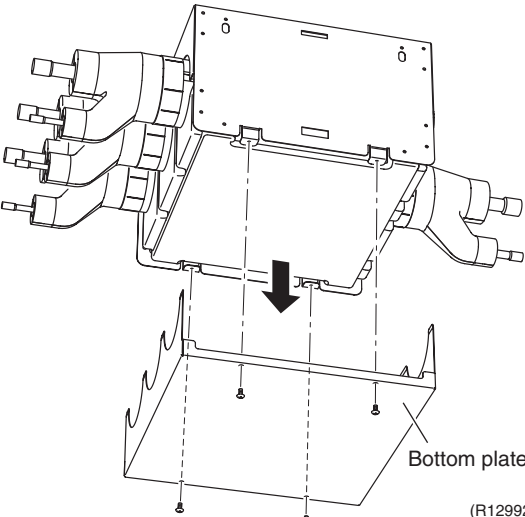
Step	Procedure	Procedure	Points
1	Detach the clamp of the wire harnesses.	 <p>(Q0509)</p>	<p><b>Preparation</b></p> <ul style="list-style-type: none"> <li>Remove the PCB assembly according to the “Removal of PCB Assembly”.</li> </ul>  <p>(R9272)</p>
2	Remove the 4 screws and remove the electrical component mounting plate.	 <p>Electrical component mounting plate</p> <p>(R12991)</p>	
3	Remove the 4 screws and remove the bottom plate.	 <p>Bottom plate</p> <p>(R12992)</p>	

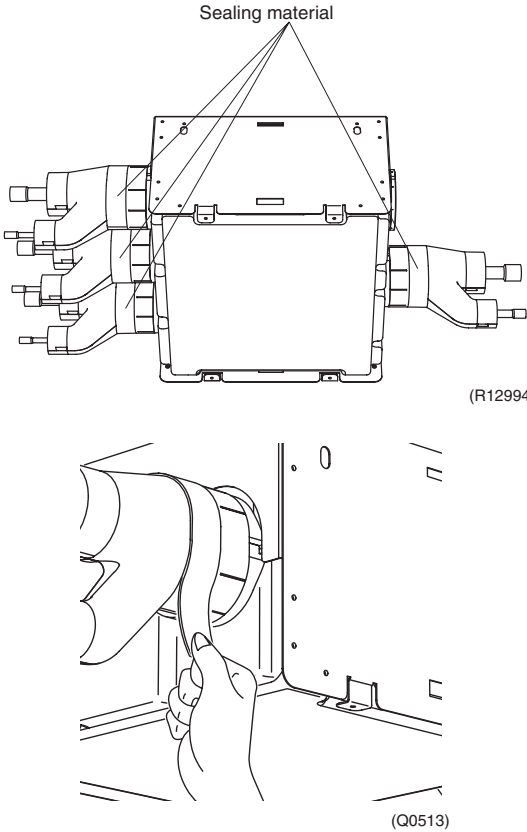
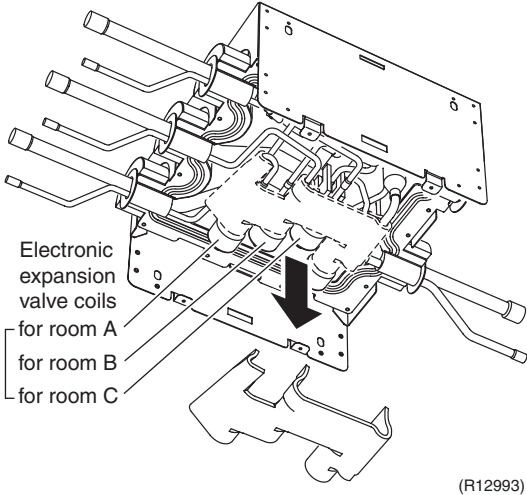
Step	Procedure	Points
4	Remove the sealing materials of the pipe insulation sleeves.	
	 <p style="text-align: center;">Sealing material</p> <p style="text-align: right;">(R12994)</p> <p style="text-align: right;">(Q0513)</p>	
5	Remove the putty.	
	 <p>Electronic expansion valve coils for room A for room B for room C</p> <p style="text-align: right;">(R12993)</p>	

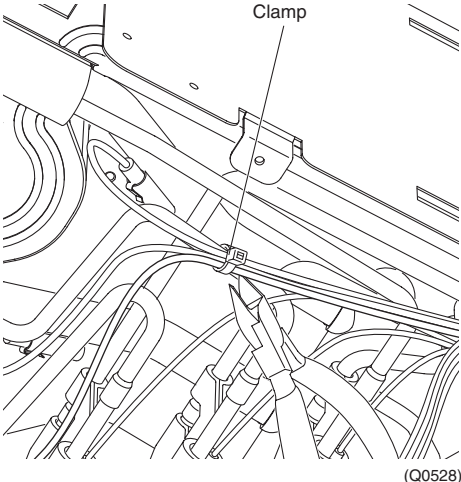
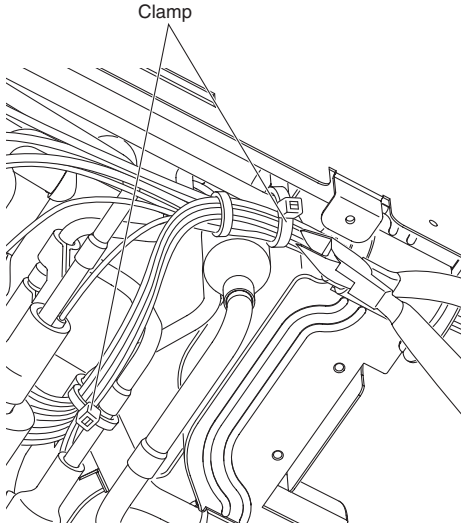
Step	Procedure	Points
6	Cut off the clamps and pull out the electronic expansion valve coils.	
	 <p>(Q0528)</p>	
	 <p>(Q0529)</p>	

# Revision History

Month / Year	Version	Revised contents
01 / 2013	Si181095	First edition

Warning



- Daikin products are manufactured for export to numerous countries throughout the world. Prior to purchase, please confirm with your local authorised importer, distributor and/or retailer whether this product conforms to the applicable standards, and is suitable for use, in the region where the product will be used. This statement does not purport to exclude, restrict or modify the application of any local legislation.
- Ask a qualified installer or contractor to install this product. Do not try to install the product yourself. Improper installation can result in water or refrigerant leakage, electrical shock, fire or explosion.
- Use only those parts and accessories supplied or specified by Daikin. Ask a qualified installer or contractor to install those parts and accessories. Use of unauthorised parts and accessories or improper installation of parts and accessories can result in water or refrigerant leakage, electrical shock, fire or explosion.
- Read the User's Manual carefully before using this product. The User's Manual provides important safety instructions and warnings. Be sure to follow these instructions and warnings.

If you have any enquiries, please contact your local importer, distributor and/or retailer.

### Cautions on product corrosion

1. Air conditioners should not be installed in areas where corrosive gases, such as acid gas or alkaline gas, are produced.
2. If the outdoor unit is to be installed close to the sea shore, direct exposure to the sea breeze should be avoided. If you need to install the outdoor unit close to the sea shore, contact your local distributor.

### Dealer

### **DAIKIN INDUSTRIES, LTD.**

Head Office:  
Umeda Center Bldg., 2-4-12, Nakazaki-Nishi,  
Kita-ku, Osaka, 530-8323 Japan

Tokyo Office:  
JR Shinagawa East Bldg., 2-18-1, Konan,  
Minato-ku, Tokyo, 108-0075 Japan

[http://www.daikin.com/global\\_ac/](http://www.daikin.com/global_ac/)

©All rights reserved