



REMOVAL PROCEDURE



SERVICE
MANUAL

S E R V I C E M A N U A L

80 kW Class

-  Outdoor Unit
-  Inverter
-  Multi Type



Service Manual Removal Procedure

Outdoor Unit

●Cooling Only

3MWKS80LV1

●Water Heater

TUL-55KVM

TUL-75KVM

TUL-100KVM

TUR-55KVM

TUR-75KVM

TUR-100KVM

Table of Contents

1. Outdoor Unit.....	2
1.1 Outer Panels / Outdoor Fan	2
1.2 Fan Motor	10
1.3 Electrical Box.....	12
1.4 PCBs	18
1.5 Reactor.....	24
1.6 Coils / Thermistors	25
1.7 Sound Blankets	27
1.8 Compressor.....	29
2. Water Heater.....	31



Note: ♦ The illustrations may be slightly different depending on the model.

1. Outdoor Unit

1.1 Outer Panels / Outdoor Fan



Warning

◆ Be sure to wait for 10 minutes or more after turning off all power supplies before disassembling work.

Step	Procedure	Points
<p>1. Remove the suction grille.</p> <p>1 Unfasten the 5 hooks.</p> <p>2 Remove the suction grille.</p>	<p style="text-align: right;">(R17585)</p>	<p>■ The hooks are secured in the clearances of the outdoor heat exchanger fins.</p>
<p>2. Remove the top panel.</p> <p>1 Remove the 8 screws.</p> <p>2 Lift up the top panel and remove it.</p>	<p style="text-align: right;">(R22022)</p>	
<p>3. Remove the front panel (2).</p> <p>1 Remove the 5 screws.</p>	<p style="text-align: right;">(R13637)</p>	<p>★ This screw is M5 × 16.</p>

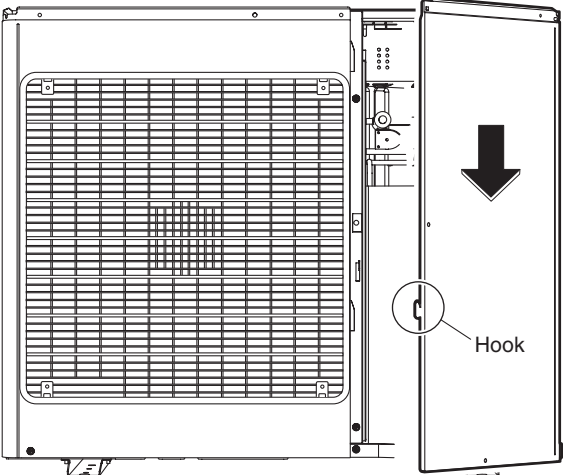
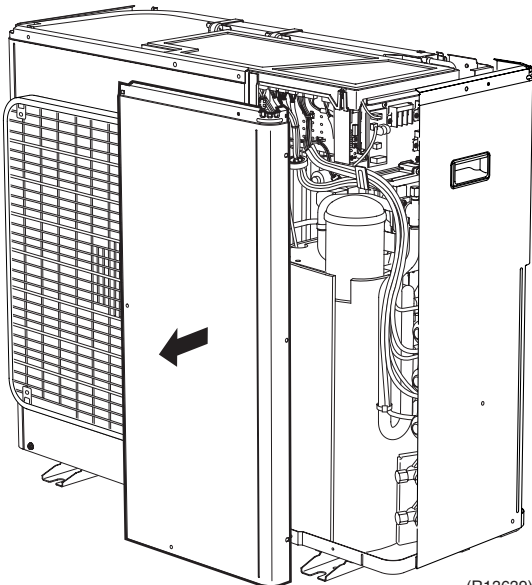
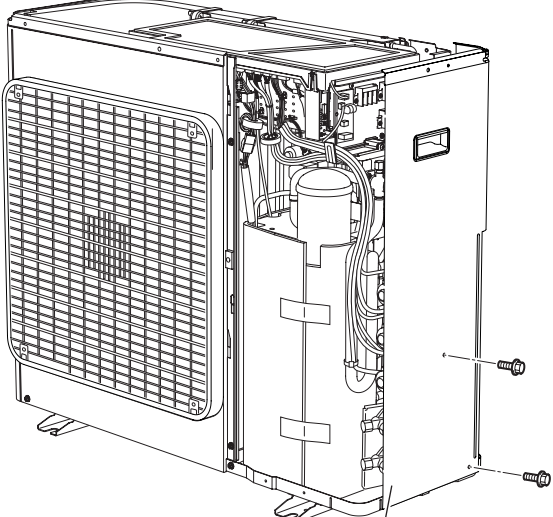
Step	Procedure	Points
2	Slide the front panel (2) downward to release the hook.	
3	Remove the front panel (2).	
4. Remove the right side panel.	 <p>(R21942)</p>	
1	Remove the 2 screws.	
	 <p>(R13639)</p>	
	 <p>Right side panel (R13640)</p>	

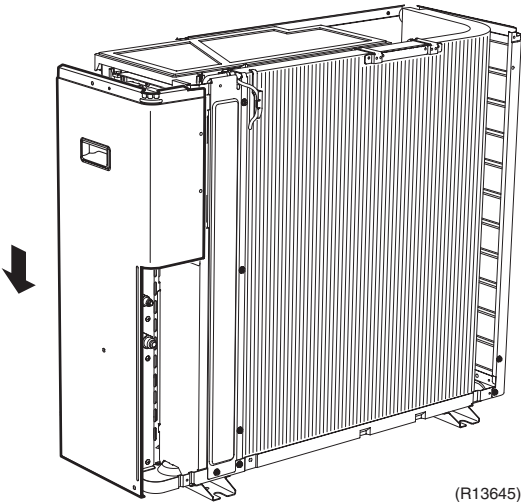
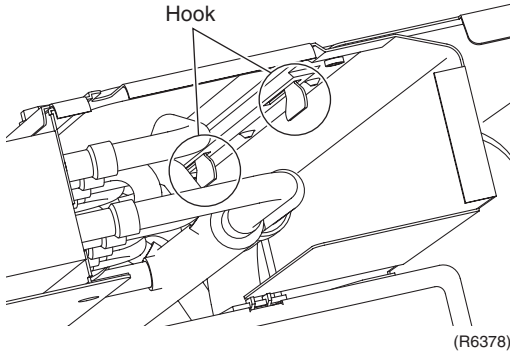
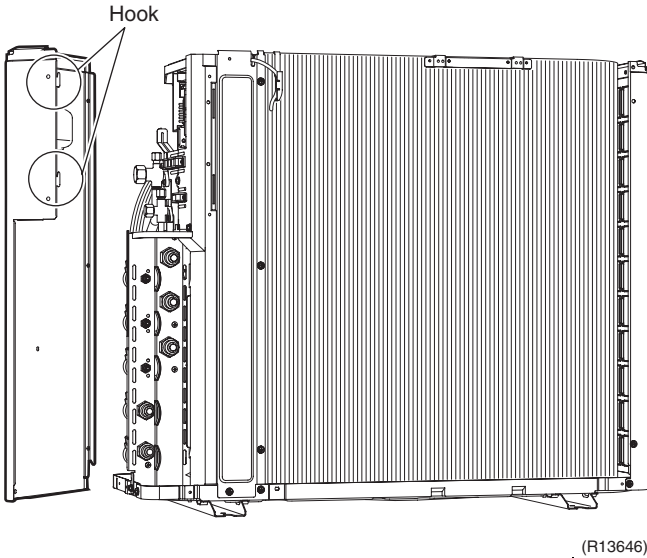
Step	Procedure	Points
2	Slide the right side panel downward to unfasten the 2 hooks on the back side.	
	 <p>(R13645)</p>	
	 <p>Hook</p> <p>(R6378)</p>	
	 <p>Hook</p> <p>(R13646)</p>	

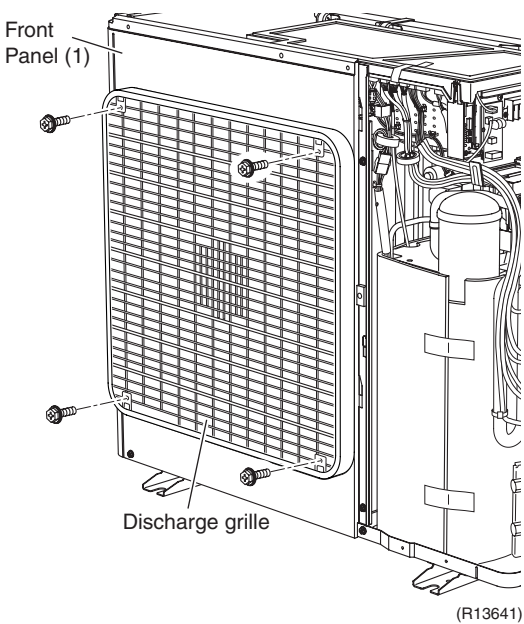
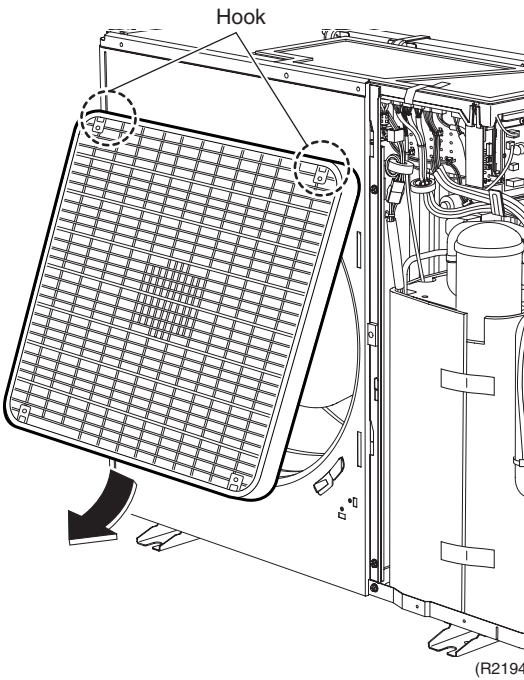
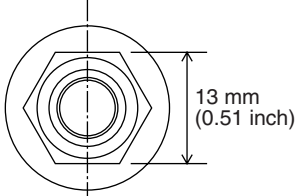
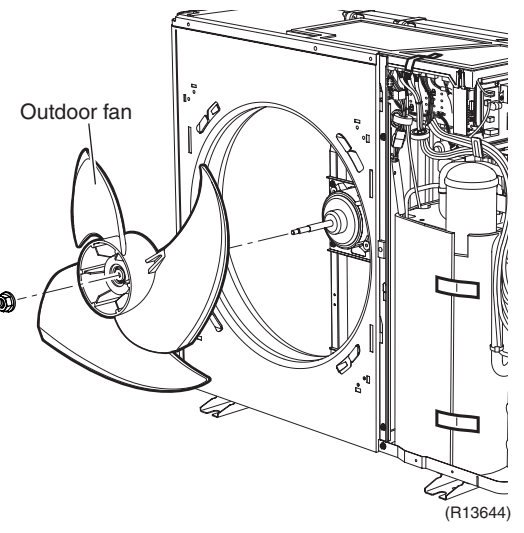
Step	Procedure	Points
5. Remove the outdoor fan and the front panel (1).	 <p>Front Panel (1)</p> <p>Discharge grille</p> <p>(R13641)</p>	<ul style="list-style-type: none"> Remove the discharge grille and outdoor fan first to remove the front panel (1).
1 Remove the 4 screws on the discharge grille. 2 Slide the discharge grille downward to unfasten the 2 hooks at the top. 3 Remove the discharge grille.	 <p>Hook</p> <p>(R21943)</p>	<ul style="list-style-type: none"> Nut size : M8  <p>13 mm (0.51 inch)</p> <p>(R18965)</p>
4 Remove the nut and remove the outdoor fan.	 <p>Outdoor fan</p> <p>(R13644)</p>	<ul style="list-style-type: none"> When reassembling, align the ▼ mark of the outdoor fan with the D-cut section of the motor shaft.

Step	Procedure	Points
5	Remove the 5 screws on the front panel (1).	
6	Release the hook and remove the front panel (1).	
6. Remove the rear panel.	1 Remove the screw on the partition plate (2) and remove the partition plate (2).	

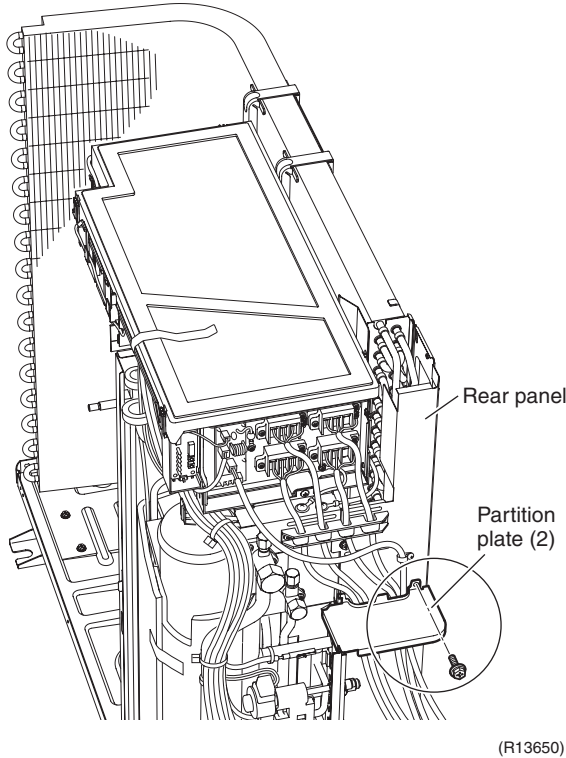
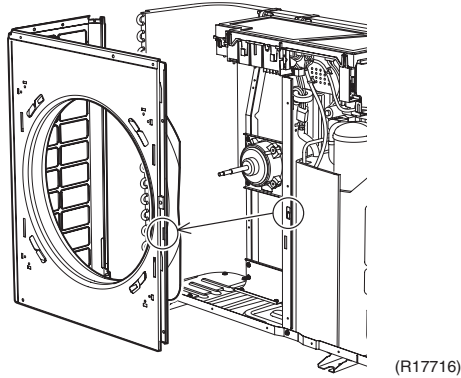
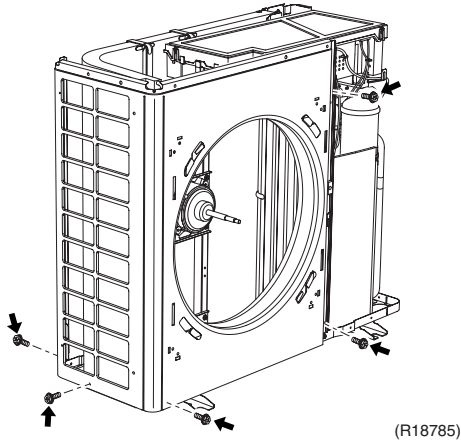

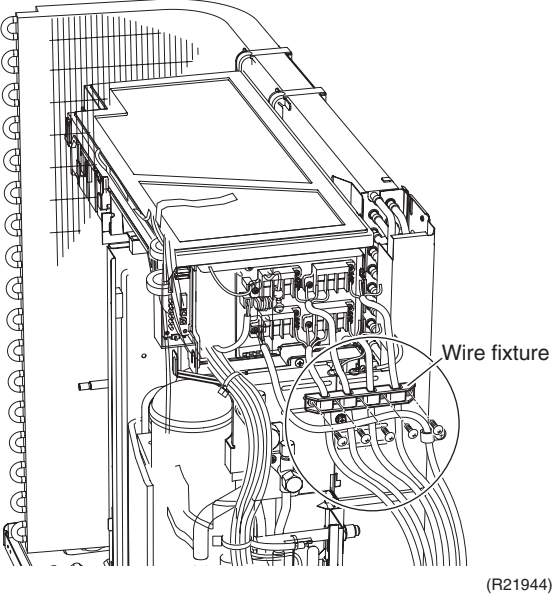
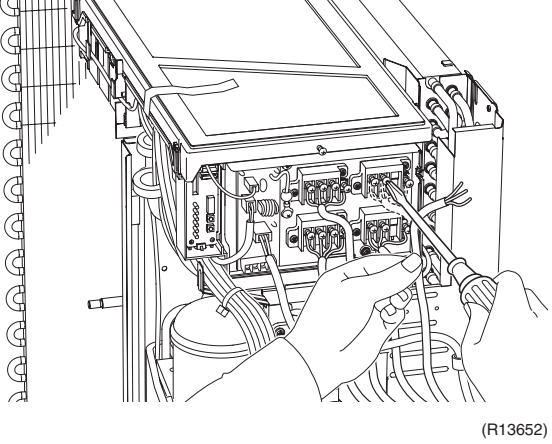
Step	Procedure	Points
2	Remove the 5 screws and remove the wire fixture.	
	 <p>(R21944)</p>	
3	Disconnect the connecting wires.	
	 <p>(R13652)</p>	
4	Disconnect the connector [S402].	[S402]: water heater thermistor
	 <p>(R22025)</p>	

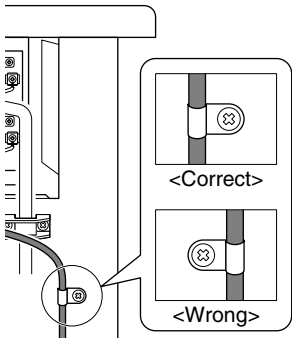
Step	Procedure	Points
5	Remove the screw of the resin clamp.	<ul style="list-style-type: none"> When reassembling, attach the resin clamp as below.
6	Remove the water heater thermistor.	
7	Pull out the holder of the outdoor temperature thermistor.	<ul style="list-style-type: none"> The holder is secured in the clearances of the outdoor heat exchanger fins.

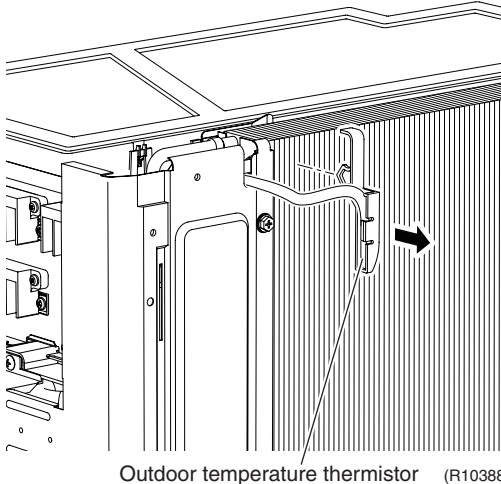
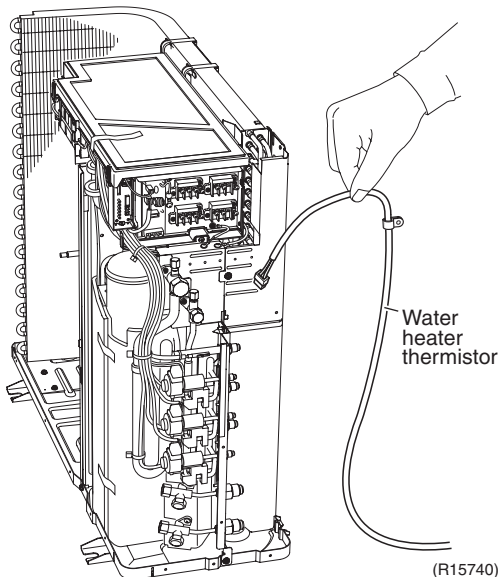
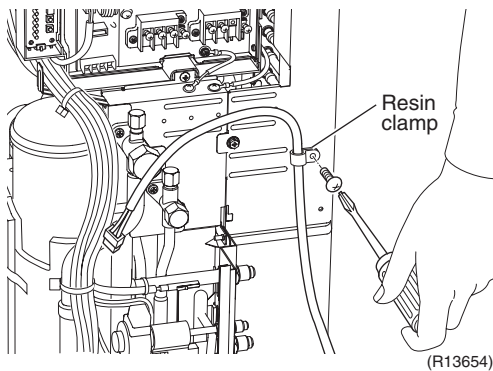

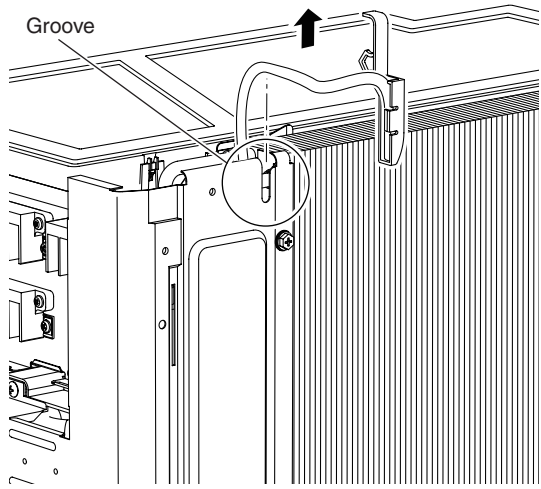
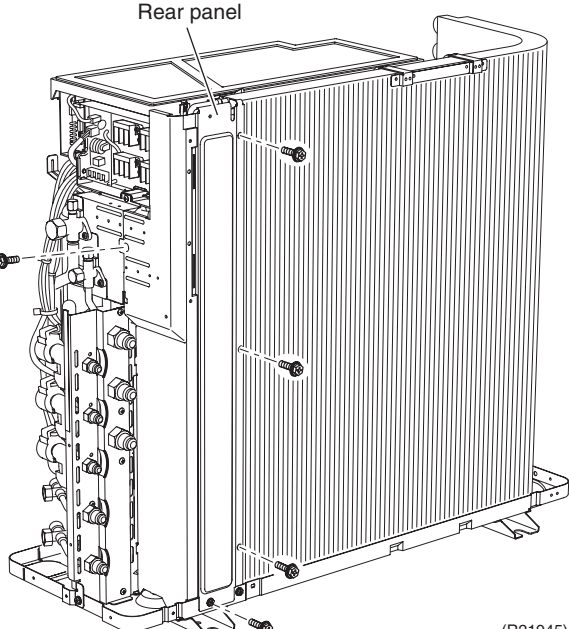
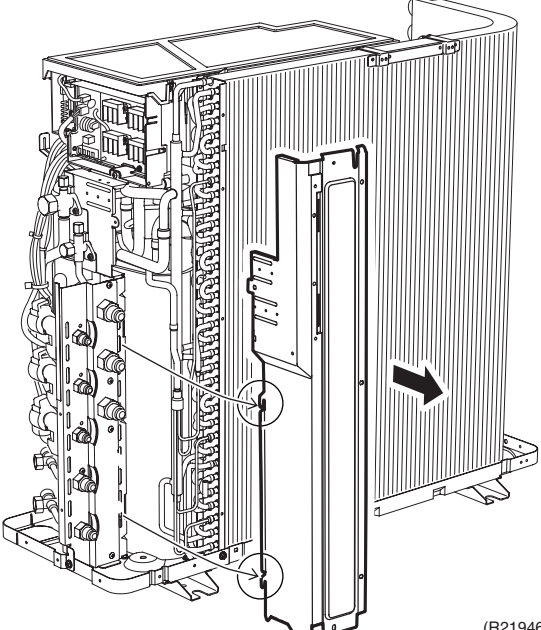
Step	Procedure	Points
8	Release the thermistor wire from the groove.	 <p>(R10389)</p>
9	Remove the 5 screws.	 <p>(R21945)</p>
10	Lift the rear panel upward to unfasten the 2 hooks.	 <p>(R21946)</p>
11	Remove the rear panel.	

1.2 Fan Motor



Warning

◆ Be sure to wait for 10 minutes or more after turning off all power supplies before disassembling work.

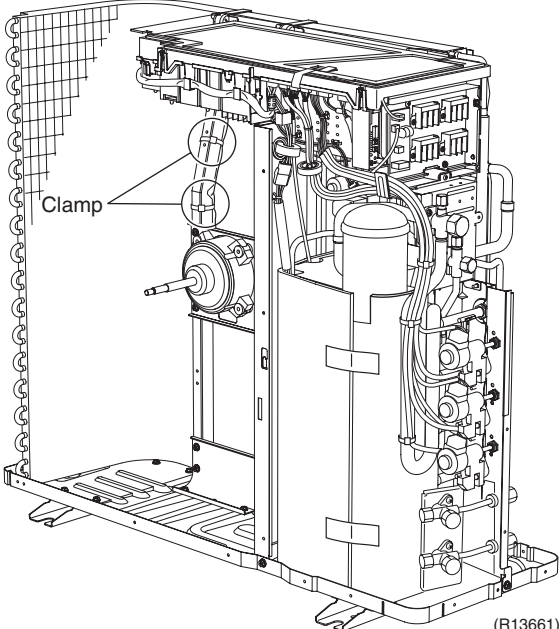
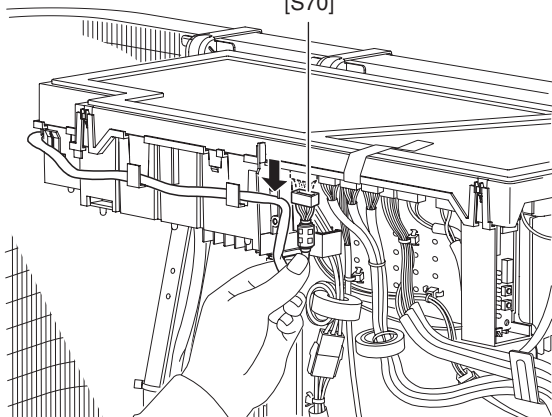
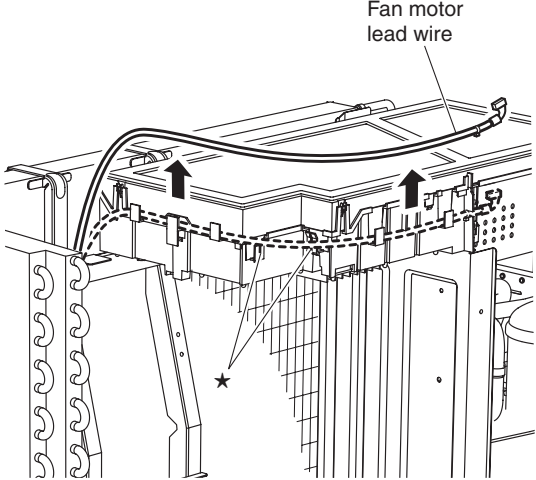
Step	Procedure	Procedure	Points
1	Cut the 2 clamps.	 <p style="text-align: right;">(R13661)</p>	
2	Disconnect the connector [S70].	 <p style="text-align: right;">(R13662)</p>	[S70]: fan motor
3	Release the fan motor lead wire from the 5 hooks.	 <p style="text-align: right;">(R13663)</p>	★: When reassembling, do not use these 2 hooks.

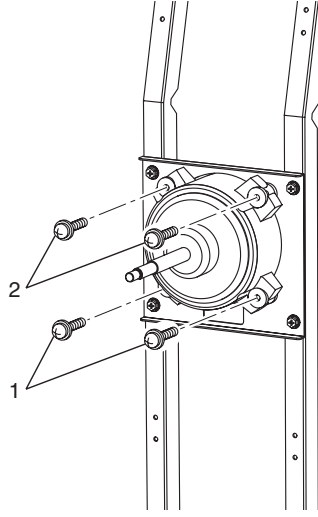
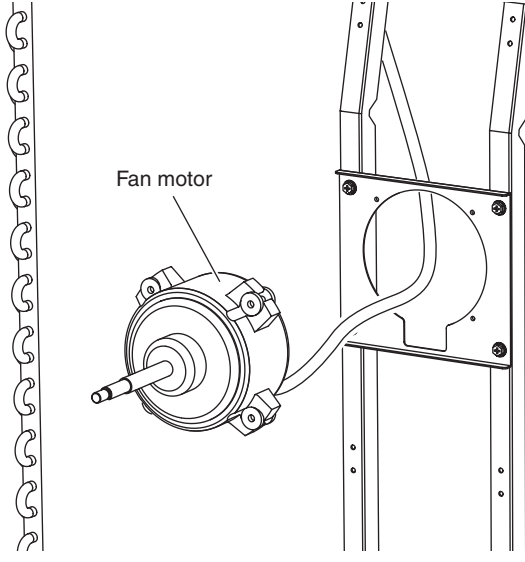
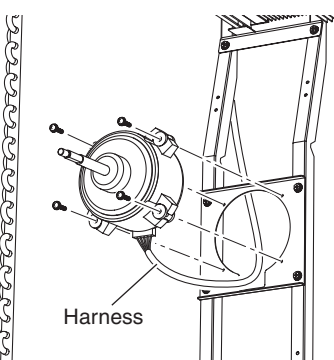
Step		Procedure	Points
4	Remove the 2 lower screws of the fan motor.	 <p>(R13664)</p>	<ul style="list-style-type: none"> Be sure to remove the lower screws first. If the upper screws are removed first, the fan motor may tilt or fall because its centre of gravity shifts to the front. It may cause injuries.
5	Remove the 2 upper screws.	 <p>(R13665)</p>	<ul style="list-style-type: none"> When reassembling, make sure that the wire harness is facing downward.  <p>(R6444)</p>
6	Remove the fan motor.		

1.3 Electrical Box



Warning

◆ Be sure to wait for 10 minutes or more after turning off all power supplies before disassembling work.

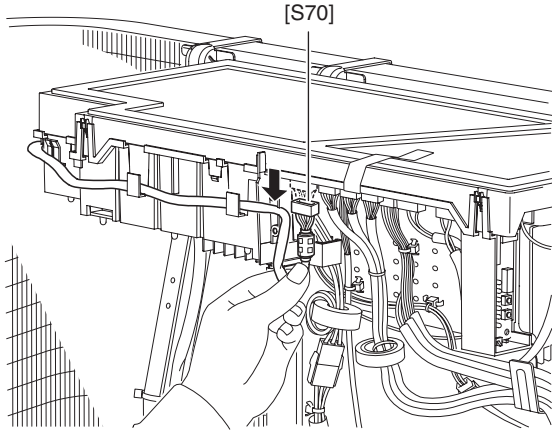
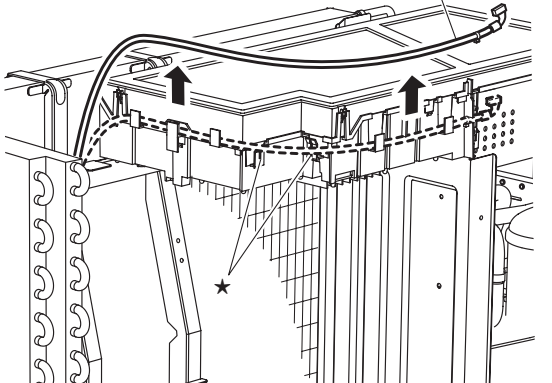
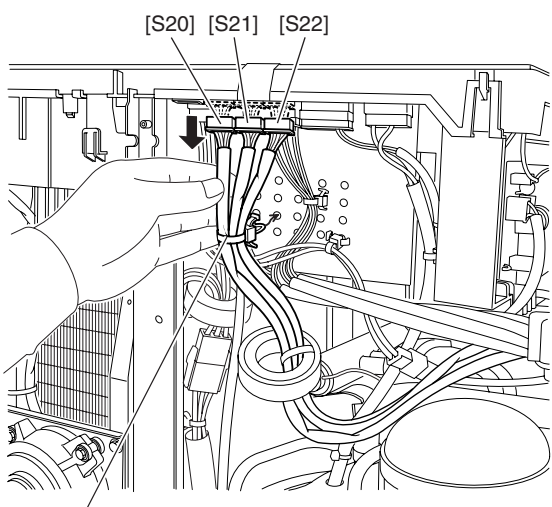
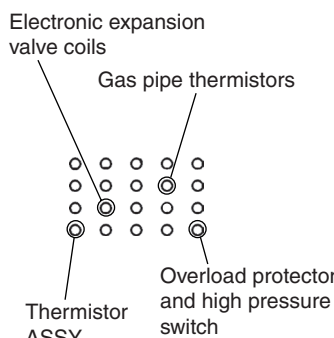
Step	Procedure	Points
1	Disconnect the connector [S70].  <p style="text-align: right;">(R13662)</p>	[S70]: fan motor
2	Release the fan motor lead wire from the 5 hooks.  <p style="text-align: right;">(R13663)</p>	★: When reassembling, do not use these 2 hooks.
3	Disconnect the connectors for the electronic expansion valve coils [S20], [S21], [S22]. Pull out the clamp.  <p style="text-align: right;">(R15741)</p>	[S20] (white): room A [S21] (red) : room B [S22] (blue) : room C ■ When reassembling, insert the clamps into the small holes as below.  <p style="text-align: right;">(R13762)</p>

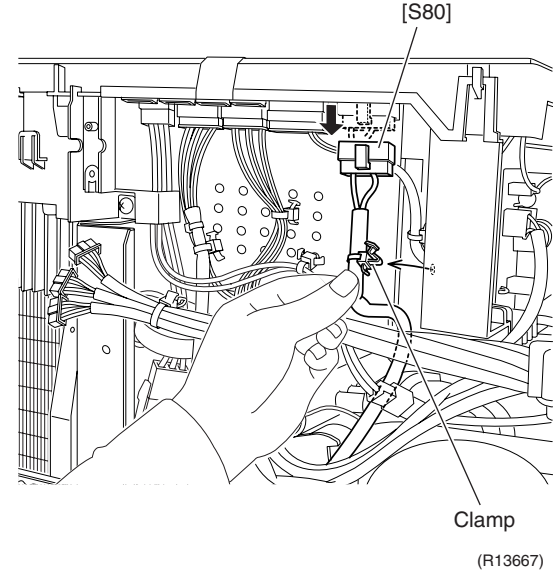
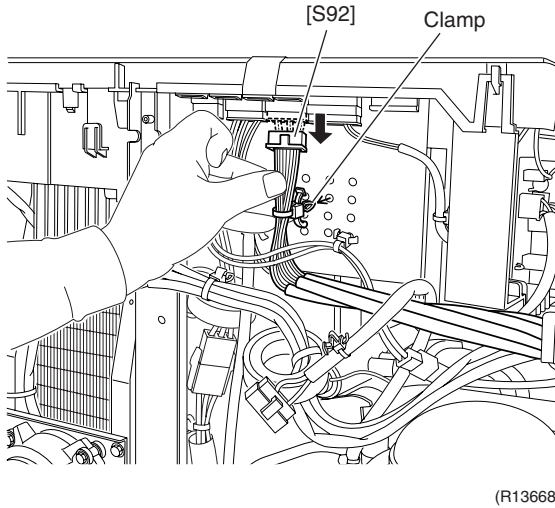
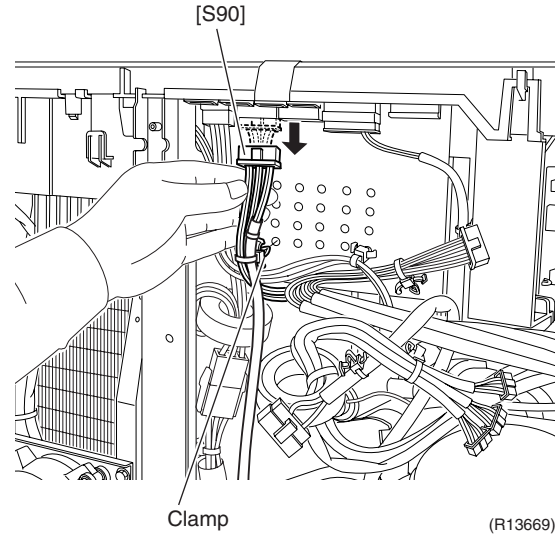
Step	Procedure	Points
4	Disconnect the connector [S80]. Pull out the clamp.	[S80]: four way valve coil
 <p style="text-align: center;">Clamp (R13667)</p>		
5	Disconnect the connector [S92]. Pull out the clamp.	[S92]: gas pipe thermistors (each room, water heater)
 <p style="text-align: center;">Clamp (R13668)</p>		
6	Disconnect the connector [S90]. Pull out the clamp.	[S90]: thermistor ASSY
 <p style="text-align: center;">Clamp (R13669)</p>		

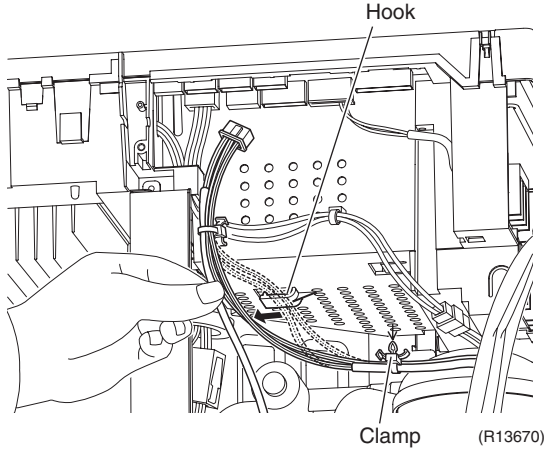
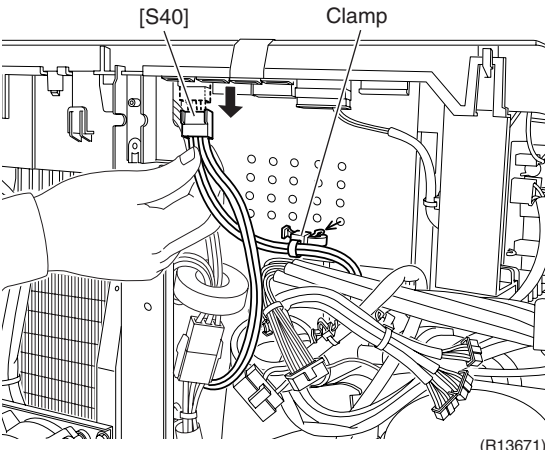
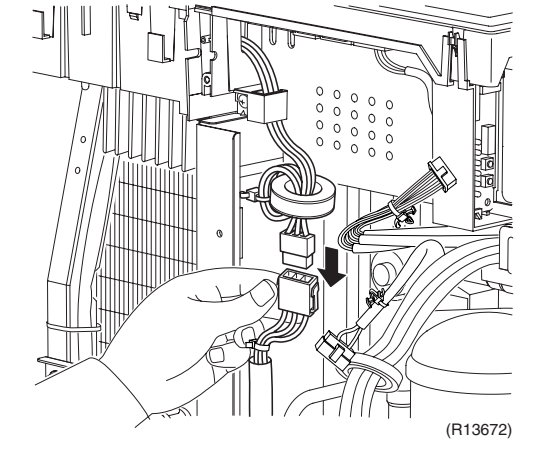
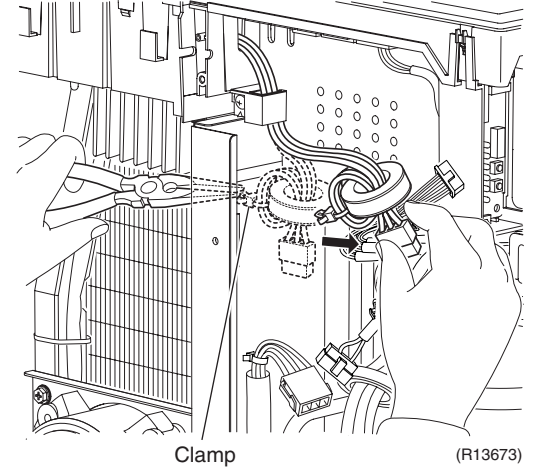
Step	Procedure	Points	
7	Release the harnesses of the thermistor ASSY from the hook on the bottom of the electrical box. Pull out the clamp.		
8	Disconnect the connector [S40]. Pull out the clamp.		[S40]: overload protector / high pressure switch
9	Disconnect the relay connector for the compressor.		
10	Pinch the clamp with pliers and pull out the clamp.		

Step	Procedure	Points
11	Remove the screw on the stop valve mounting plate.	
12	Remove the screw on the partition plate (1).	
13	Remove the 2 screws to detach the earth / ground wires.	

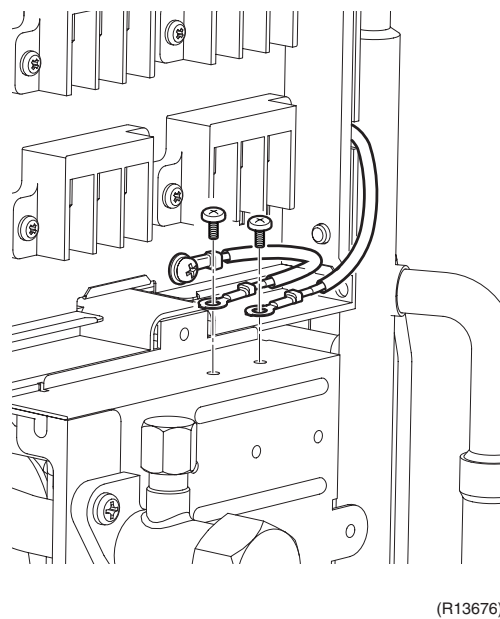
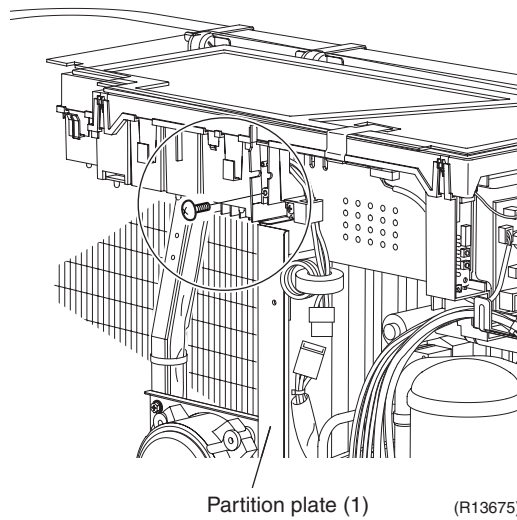
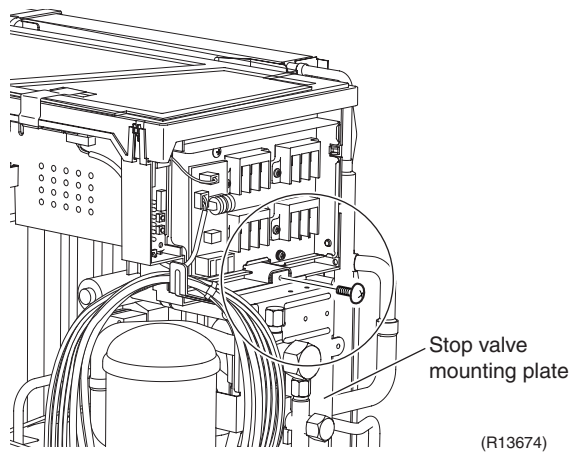

Step	Procedure	Points
14	Cut the clamp.	
15	Pull out the outdoor heat exchanger thermistor.	<ul style="list-style-type: none"> Be careful not to lose the clip for the thermistor.

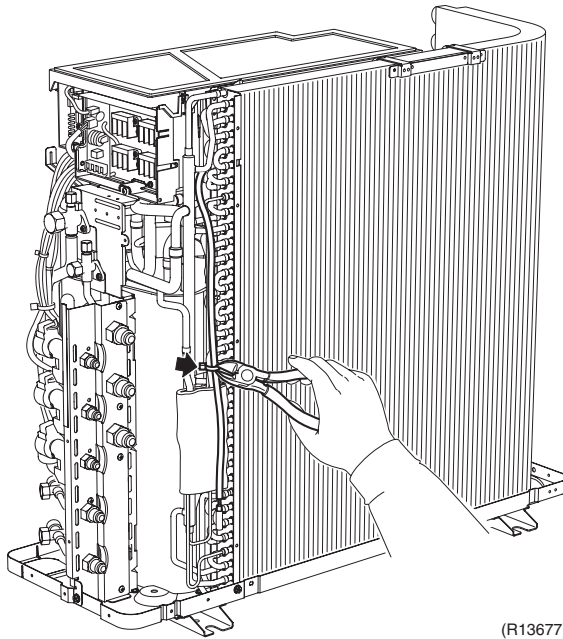

(R13677)

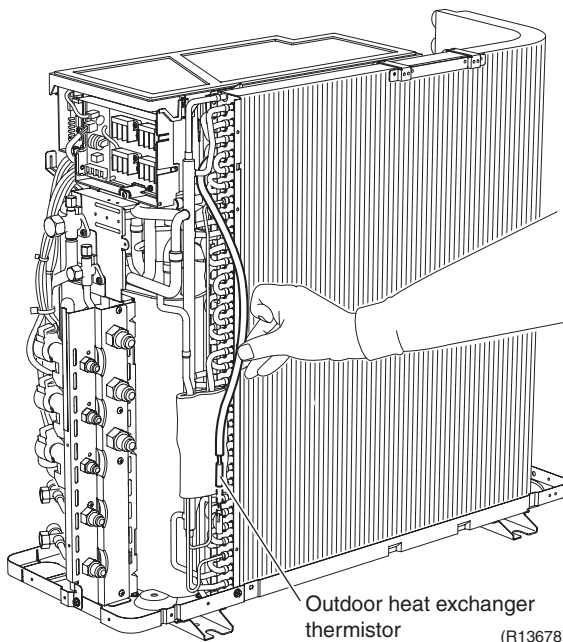

Outdoor heat exchanger thermistor

(R13678)

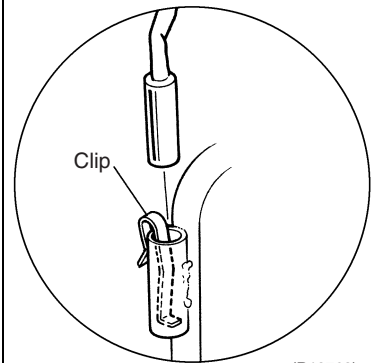

(R13763)

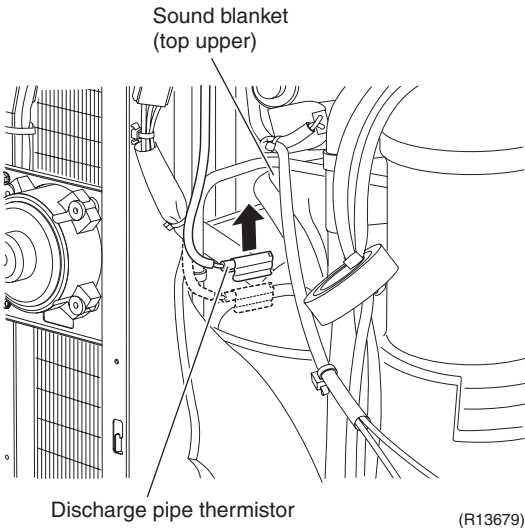
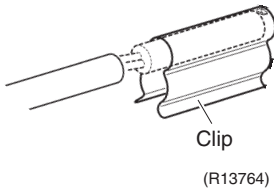
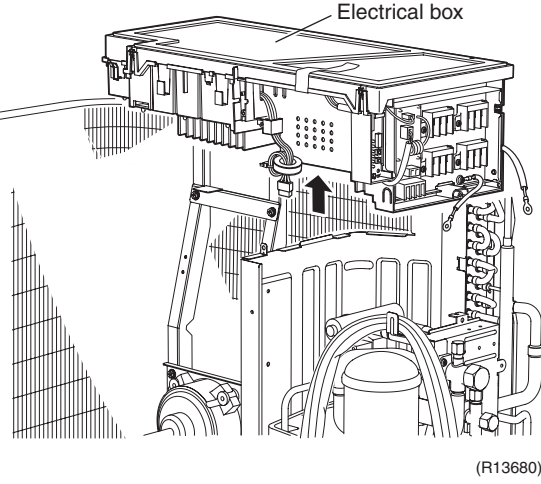
Step	Procedure	Points	
<p>16</p>	<p>Release the discharge pipe thermistor under the sound blanket (top upper).</p>		<ul style="list-style-type: none"> ■ Be careful not to lose the clip for the thermistor. 
<p>17</p>	<p>Lift up the electrical box and remove it.</p>		

1.4 PCBs



Warning

◆ Be sure to wait for 10 minutes or more after turning off all power supplies before disassembling work.

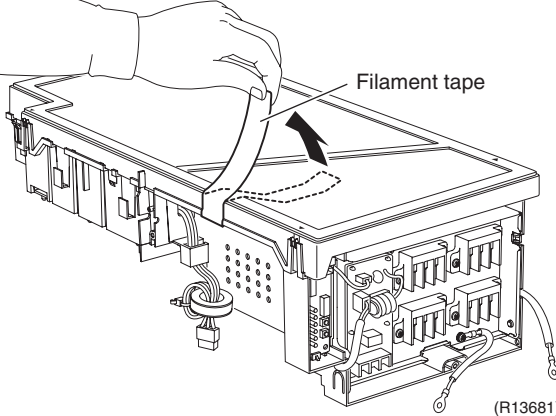
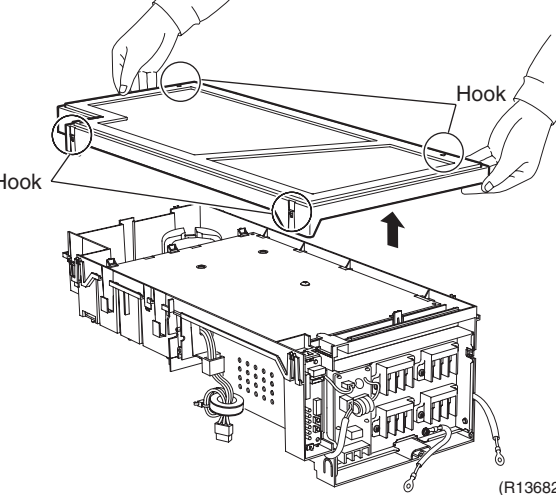
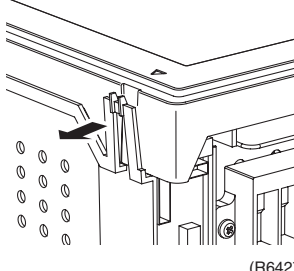
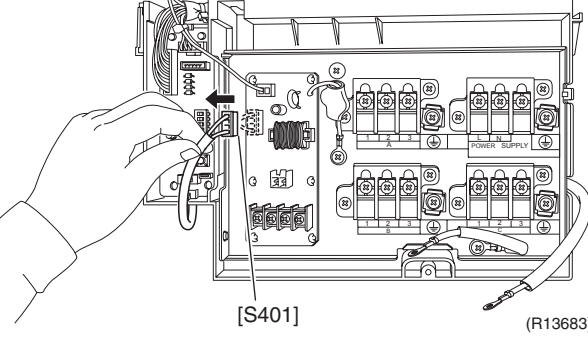
Step	Procedure	Points
<p>1. Remove the electrical box cover.</p> <p>1 Peel off the filament tape.</p> <p>2 Unfasten the 4 hooks and remove the electrical box cover.</p>	 <p>(R13681)</p>  <p>(R13682)</p>	<p>■ The hooks are marked with ▼.</p>  <p>(R6427)</p>
<p>2. Remove the filter PCB.</p> <p>1 Disconnect the connector [S401].</p>	 <p>[S401] (R13683)</p>	<p>[S401]: to main PCB</p>

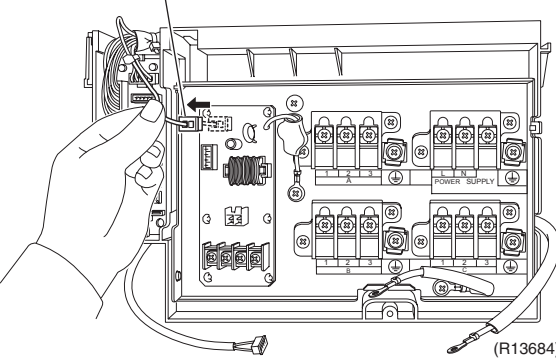
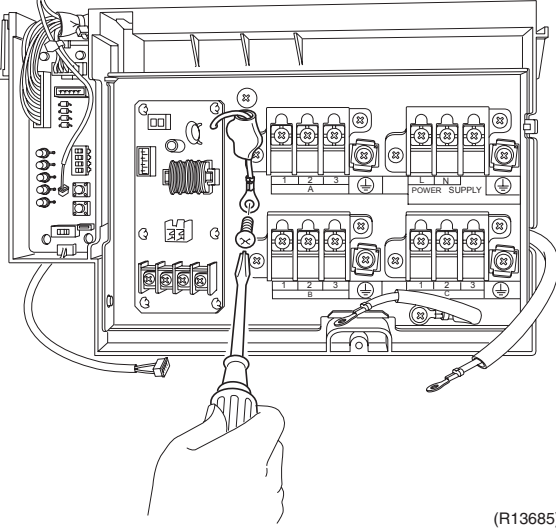
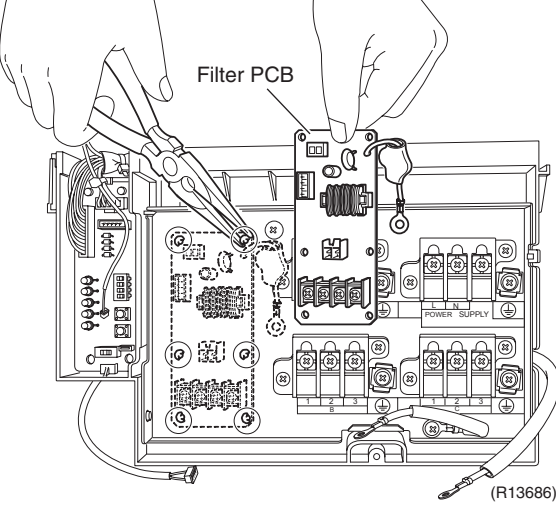
Step	Procedure	Points	
2	Disconnect the connector [S404].	[S404]  (R13684)	[S404]: to main PCB
3	Remove the screw and release the earth / ground wire.	 (R13685)	
4	Pull out the 6 spacers with pliers and remove the filter PCB.	Filter PCB  (R13686)	

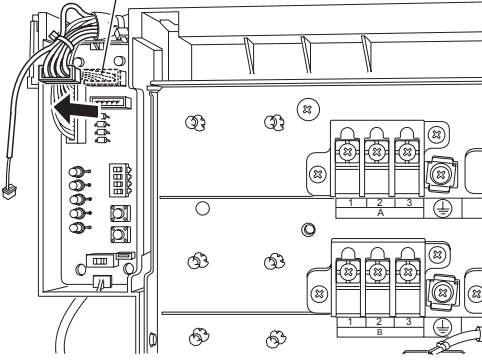
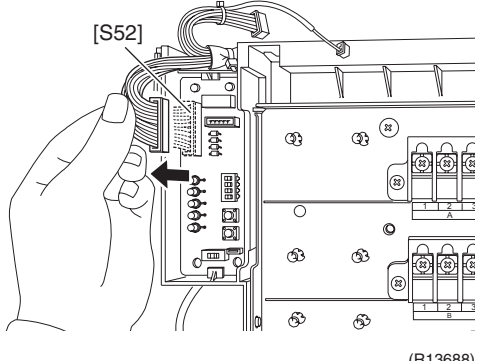
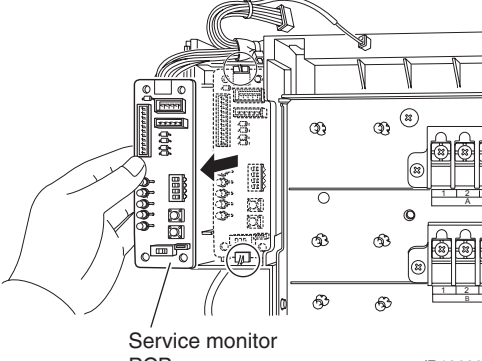
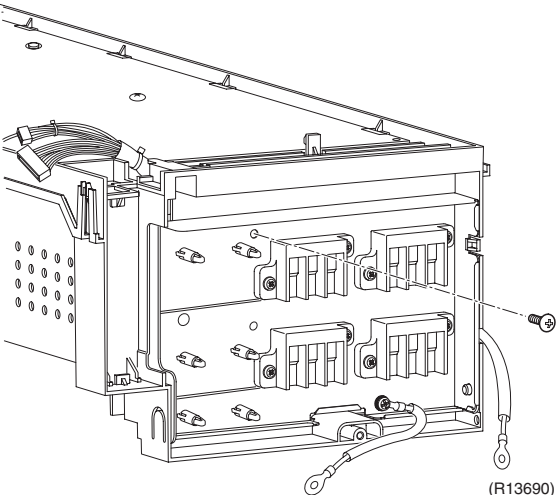
Step	Procedure	Points
<p>3. Remove the service monitor PCB.</p> <p>1 Disconnect the connector [S102].</p> <p>2 Disconnect the connector [S52].</p> <p>3 Unfasten the 2 hooks and remove the service monitor PCB.</p>	<p>[S102]</p>  <p>(R13687)</p> <p>[S52]</p>  <p>(R13688)</p> <p>Service monitor PCB</p>  <p>(R13689)</p>	<p>[S102]: to main PCB</p> <p>[S52]: to main PCB</p>
<p>4. Remove the main PCB.</p> <p>1 Remove the screw.</p>	 <p>(R13690)</p>	

Step	Procedure	Points
2	Unfasten the hook.	
3	Open the terminal board.	
4	Disconnect the connectors.	

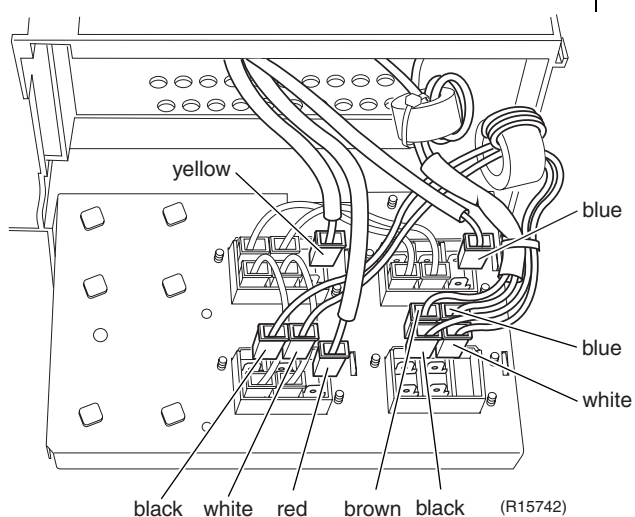
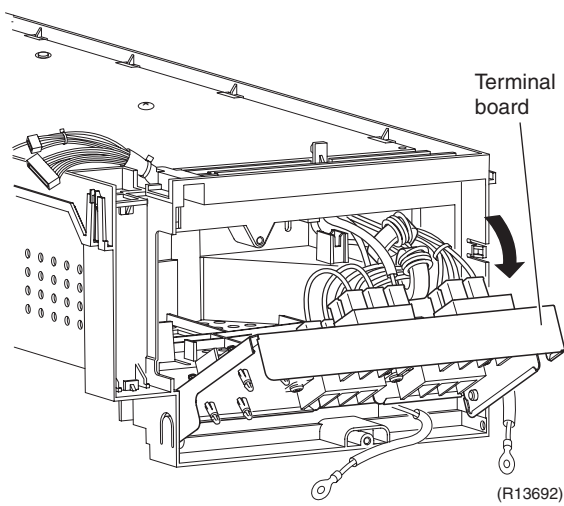
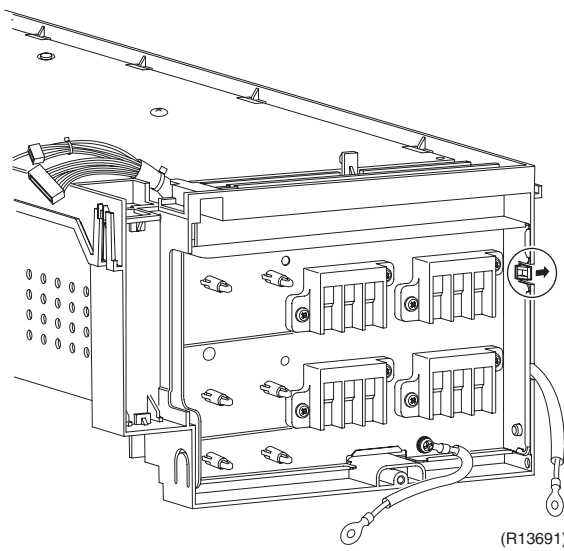

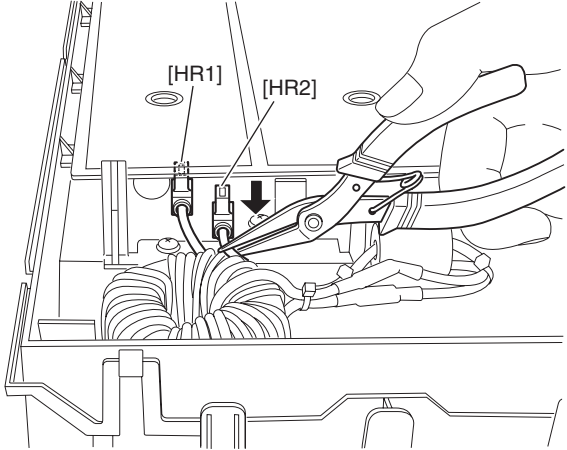
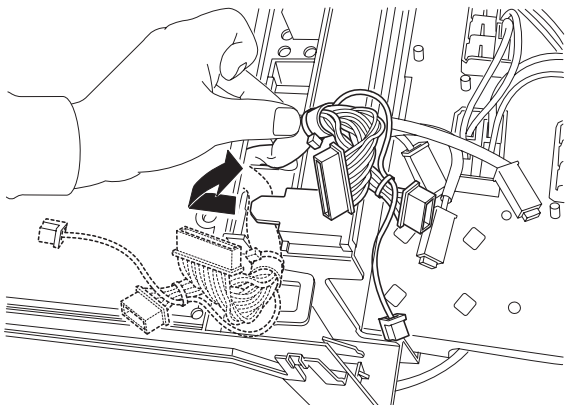
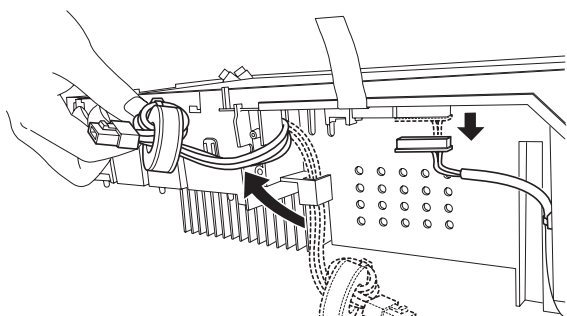
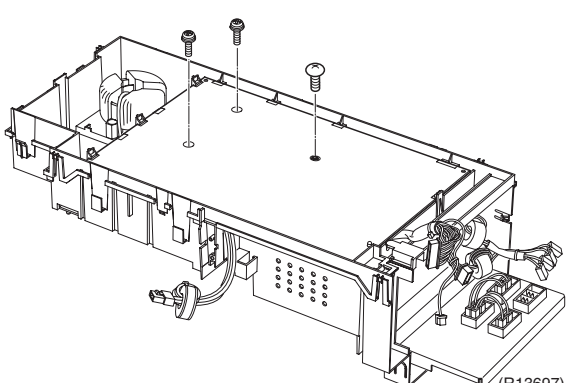
Step	Procedure	Procedure	Points
5	Disconnect the 2 connectors for the reactor [HR1], [HR2].	 <p>(R13694)</p>	[HR1]: white [HR2]: blue
6	Release the harnesses from the hook.	 <p>(R13695)</p>	
7	Release the harnesses from the hook.	 <p>(R13696)</p>	
8	Remove the 3 screws.	 <p>(R13697)</p>	

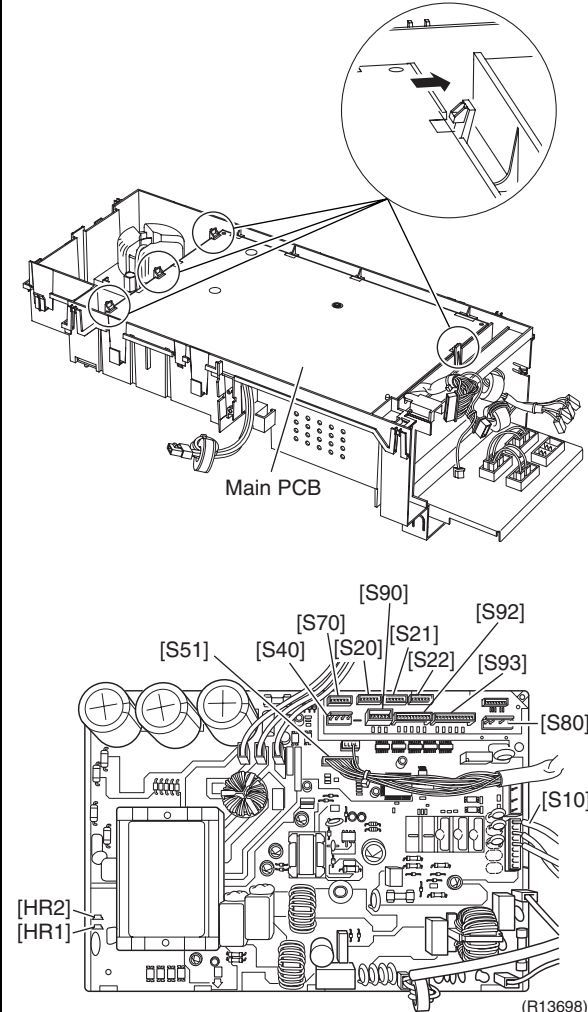
Step	Procedure	Points
<p>9</p>	<p>Unfasten the 4 hooks and remove the main PCB.</p> 	

1.5 Reactor



Warning

◆ Be sure to wait for 10 minutes or more after turning off all power supplies before disassembling work.

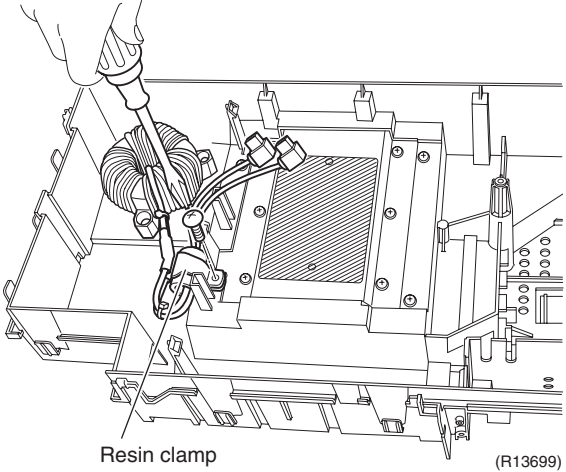
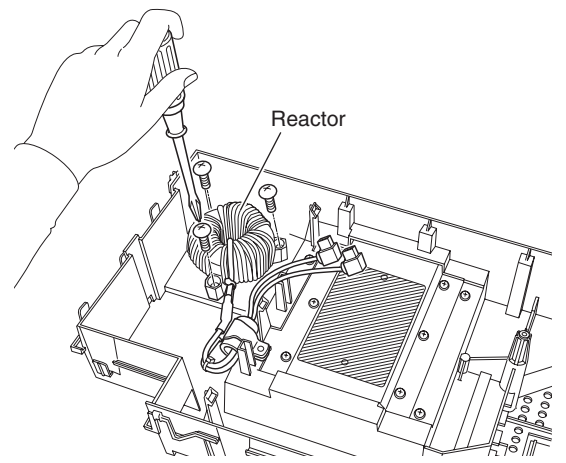
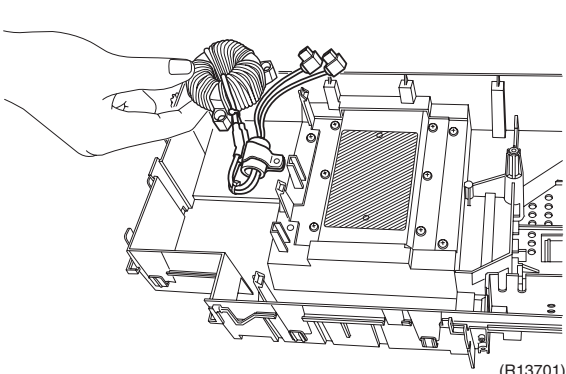
Step	Procedure	Points	Points
1	Remove the screw of the resin clamp.	 <p>Resin clamp (R13699)</p>	
2	Remove the 3 screws of the reactor.	 <p>Reactor (R13700)</p>	
3	Remove the reactor.	 <p>(R13701)</p>	

1.6 Coils / Thermistors



Warning

- ◆ Be sure to wait for 10 minutes or more after turning off all power supplies before disassembling work.

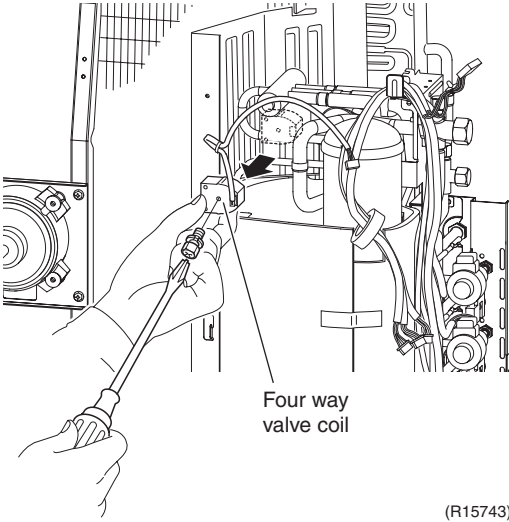
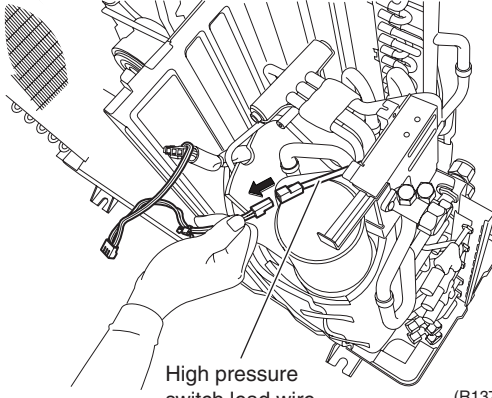
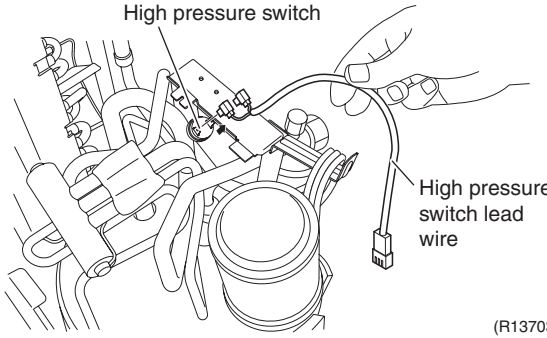
Step	Procedure	Points
1	Remove the screw and remove the four way valve coil.	 <p style="text-align: right;">(R15743)</p>
2	Disconnect the relay connector for the high pressure switch lead wire.	 <p style="text-align: right;">(R13768)</p>
3	Remove the high pressure switch lead wire.	 <p style="text-align: right;">(R13703)</p>

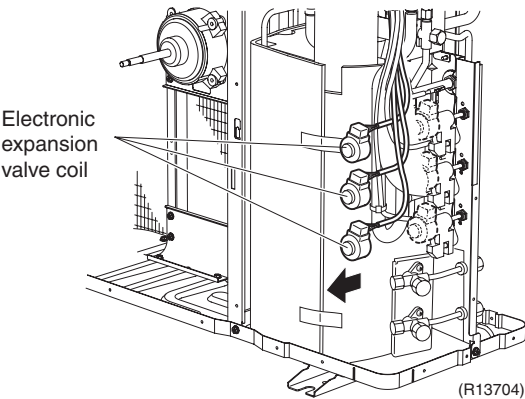
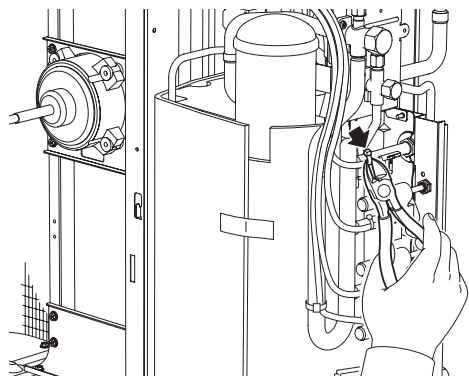
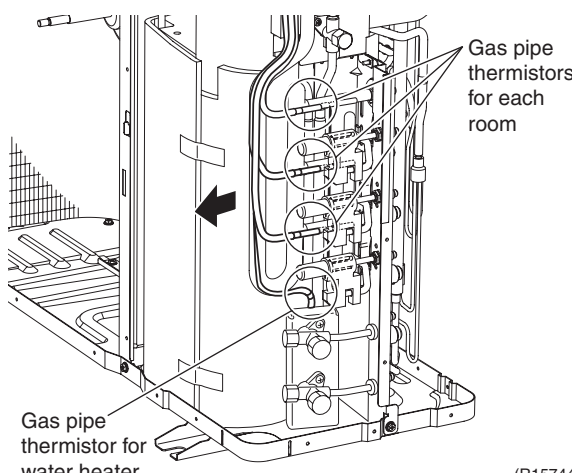
Step	Procedure	Procedure	Points
4	Pull out the electronic expansion valve coils.	 <p>Electronic expansion valve coil</p> <p>(R13704)</p>	
5	Cut the clamps of the gas pipe thermistor.	 <p>(R13705)</p>	
6	Pull out the gas pipe thermistors.	 <p>Gas pipe thermistors for each room</p> <p>Gas pipe thermistor for water heater</p> <p>(R15744)</p>	

1.7 Sound Blankets



Warning

- ◆ Be sure to wait for 10 minutes or more after turning off all power supplies before disassembling work.

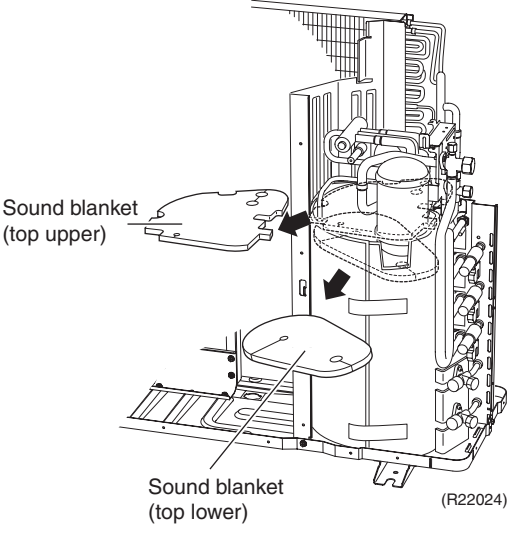
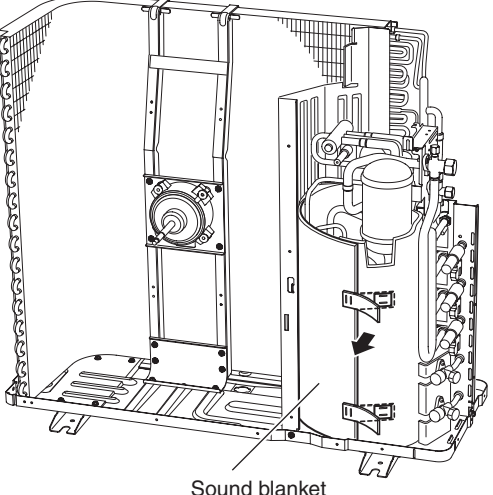
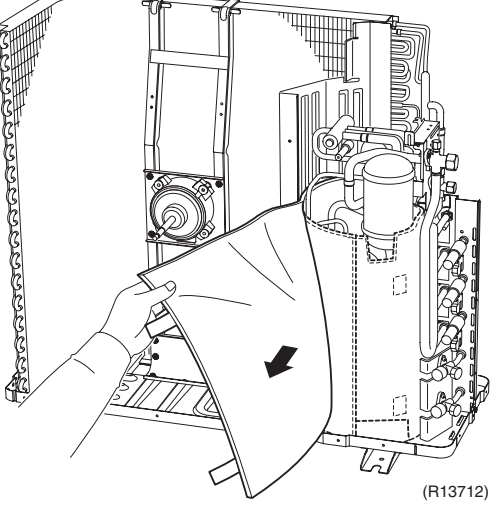
Step	Procedure	Procedure	Points
1	Remove the 2 sound blankets (top upper) (top lower).	 <p style="text-align: center;">Sound blanket (top upper)</p> <p style="text-align: center;">Sound blanket (top lower) (R22024)</p>	<ul style="list-style-type: none"> ■ The sound blanket is fragile. Carefully pass the blanket through the discharge pipe.
2	Open the sound blanket (outer).	 <p style="text-align: center;">Sound blanket (outer) (R13711)</p>	
3	Remove the sound blanket (outer).	 <p style="text-align: center;">(R13712)</p>	

Step	Procedure	Points
4	Remove the sound blanket (inner) through the mufflers.	<ul style="list-style-type: none"> ■ The sound blanket is fragile. Be careful of the notches of the compressor mount (3 locations).

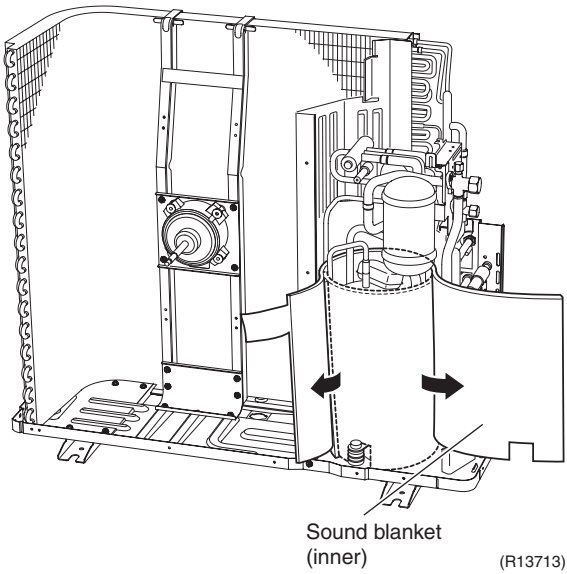

1.8 Compressor



Warning

- ◆ Be sure to wait for 10 minutes or more after turning off all power supplies before disassembling work.
- ◆ Be careful not to get yourself burnt with the pipes and other parts that are heated by the gas brazing machine.
- ◆ If the refrigerant gas leaks during work, ventilate the room. (If the refrigerant gas is exposed to flames, toxic gas may be generated.)
- ◆ Since it may happen that the refrigerant oil in the compressor catches fire, prepare wet cloth so as to extinguish fire immediately.



Caution

- ◆ From the viewpoint of global environment protection, do not discharge the refrigerant gas in the atmosphere. Make sure to collect all the refrigerant gas.
- ◆ Restore the piping by non-oxidation brazing.



Note

- ◆ Before working, make sure that the refrigerant gas is empty in the circuit.
- ◆ Be sure to apply nitrogen replacement when heating up the brazed part.
- ◆ Do not use a metal saw for cutting pipes by all means because the sawdust comes into the circuit.
- ◆ When withdrawing the pipes, be careful not to pinch them firmly with pliers. The pipes may get deformed.
- ◆ Provide a protective sheet or a steel plate so that the brazing flame cannot influence peripheries.
- ◆ Be careful so as not to burn the compressor terminals, the name plate, the outdoor heat exchanger fin.
- ◆ In case of difficulty with gas brazing machine.
 1. Disconnect the brazed part where is easy to disconnect and restore.
 2. Cut pipes on the main unit with a tube cutter in order to make it easy to disconnect.

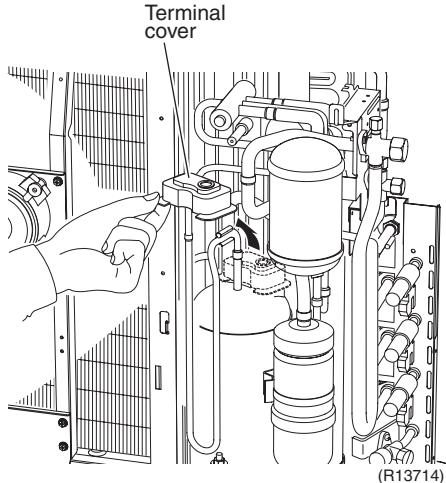
Step	Procedure	Points
1	Remove the terminal cover.	

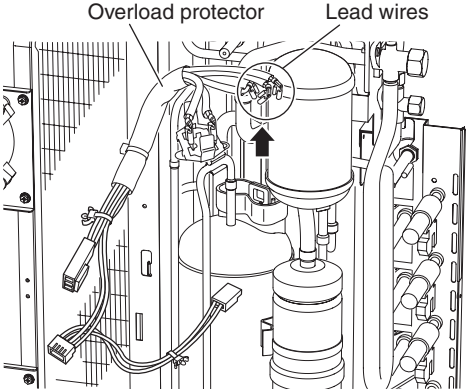
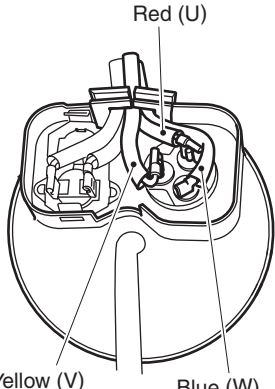
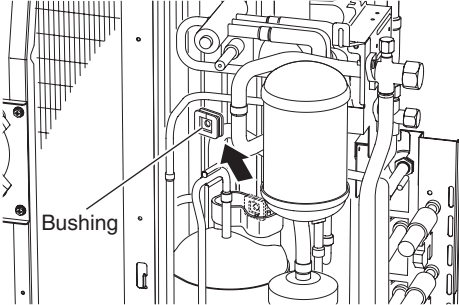
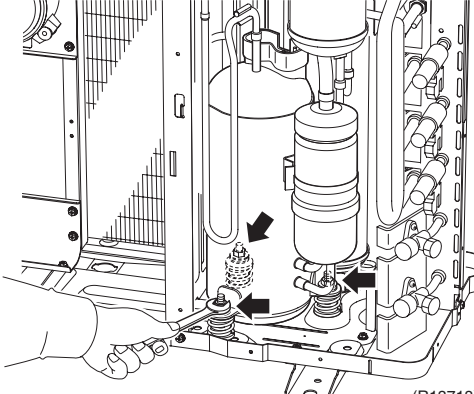
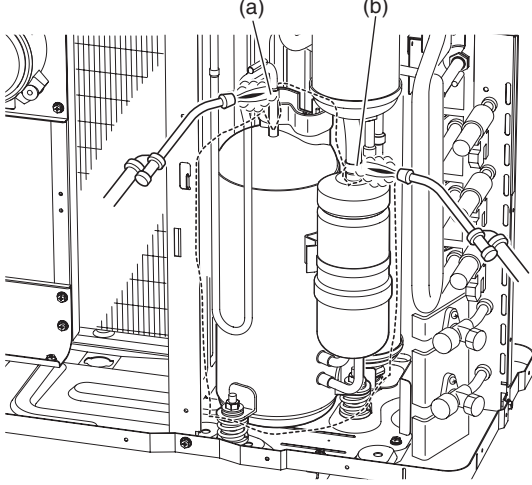
Step	Procedure	Procedure	Points
2	Disconnect the 3 lead wires of the compressor.	 <p>(R22026)</p>	 <p>(R12436)</p>
3	Remove the overload protector.		
4	Remove the bushing.	 <p>(R13716)</p>	
5	Remove the 3 nuts.	 <p>(R13718)</p>	
6	Heat up the brazed part of the discharge side and disconnect the part (a).	 <p>(R13717)</p>	
7	Heat up the brazed part of the suction side and disconnect the part (b).		
8	Lift up the compressor and remove it.		

2. Water Heater



Warning

- ◆ Be sure to wait for 10 minutes or more after turning off all power supplies before disassembling work.

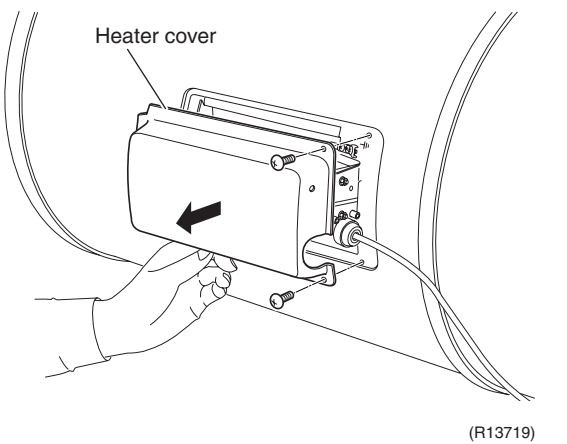
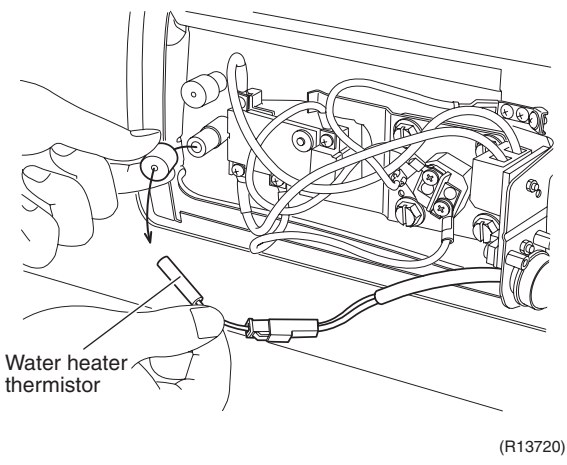
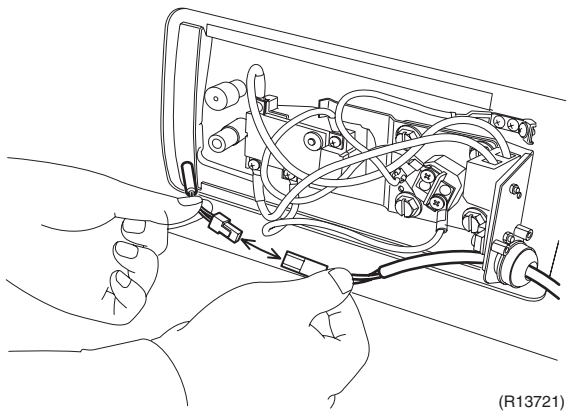
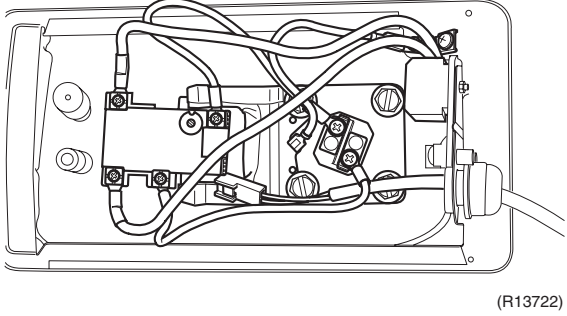
Step	Procedure	Points
1	Remove the 2 screws and remove the heater cover.	
	 <p>Heater cover</p> <p>(R13719)</p>	
2	Pull out the water heater thermistor.	
	 <p>Water heater thermistor</p> <p>(R13720)</p>	
3	Disconnect the connector of the water heater cable.	
	 <p>(R13721)</p>  <p>(R13722)</p>	

Revision History

Month / Year	Version	Revised contents
05 / 2015	Si121557E	First edition

Warning



- Daikin products are manufactured for export to numerous countries throughout the world. Prior to purchase, please confirm with your local authorised importer, distributor and/or retailer whether this product conforms to the applicable standards, and is suitable for use, in the region where the product will be used. This statement does not purport to exclude, restrict or modify the application of any local legislation.
- Ask a qualified installer or contractor to install this product. Do not try to install the product yourself. Improper installation can result in water or refrigerant leakage, electrical shock, fire or explosion.
- Use only those parts and accessories supplied or specified by Daikin. Ask a qualified installer or contractor to install those parts and accessories. Use of unauthorised parts and accessories or improper installation of parts and accessories can result in water or refrigerant leakage, electrical shock, fire or explosion.
- Read the user's manual carefully before using this product. The user's manual provides important safety instructions and warnings. Be sure to follow these instructions and warnings.

If you have any enquiries, please contact your local importer, distributor and/or retailer.

Cautions on product corrosion

1. Air conditioners should not be installed in areas where corrosive gases, such as acid gas or alkaline gas, are produced.
2. If the outdoor unit is to be installed close to the sea shore, direct exposure to the sea breeze should be avoided. If you need to install the outdoor unit close to the sea shore, contact your local distributor.

Dealer

DAIKIN INDUSTRIES, LTD.

Head Office:
Umeda Center Bldg., 2-4-12, Nakazaki-Nishi,
Kita-ku, Osaka, 530-8323 Japan

Tokyo Office:
JR Shinagawa East Bldg., 2-18-1, Konan,
Minato-ku, Tokyo, 108-0075 Japan

<http://www.daikin.com/products/ac/>

©All rights reserved