



REMOVAL PROCEDURE



SERVICE
MANUAL

S E R V I C E M A N U A L

11.5 kW Class

-  Outdoor Unit
-  Inverter
-  Multi Type

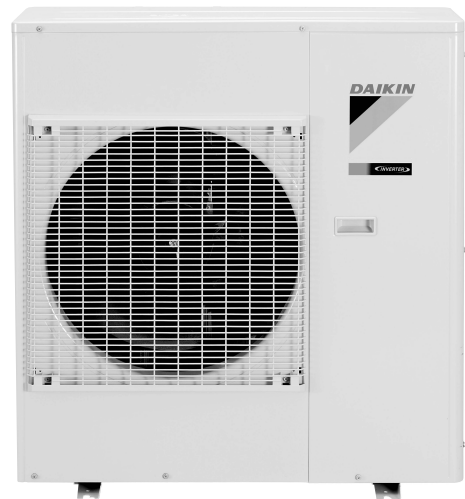

Service Manual Removal Procedure

Outdoor Unit

●Heat Pump
4MXS115HV2C

Table of Contents

1. Removal of Outer Panels	2
2. Removal of Fan Motor.....	12
3. Removal of Electrical Box	14
4. Removal of PCBs.....	18
5. Removal of Coils / Thermistors	23
6. Removal of Sound Blanket.....	27
7. Removal of Compressor	30

1. Removal of Outer Panels

Procedure

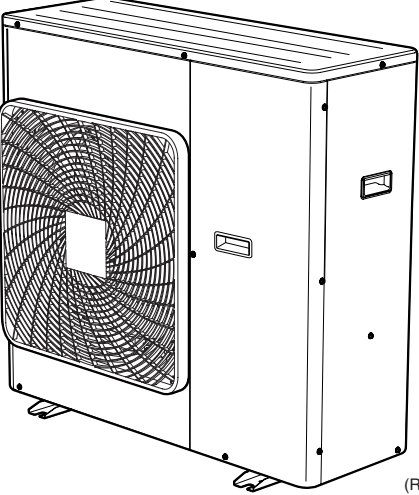
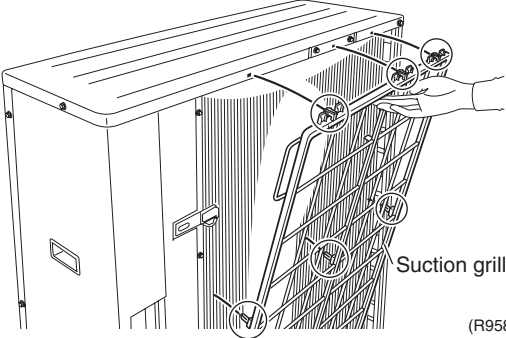
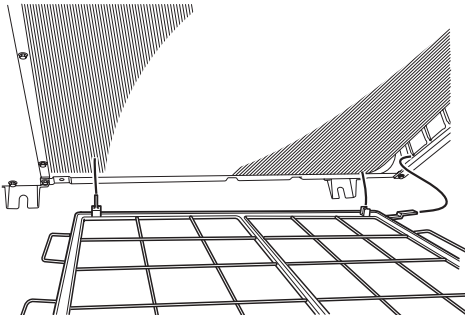
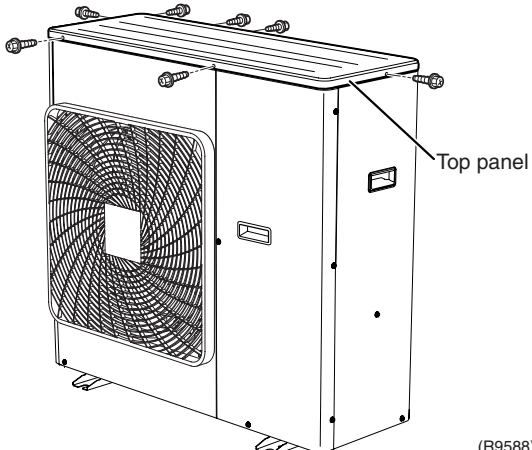

Warning Be sure to wait 10 minutes or more after turning off all power supplies before disassembling work.

Step	Procedure	Points
External appearance	 <p style="text-align: right;">(R9585)</p>	
1. Removal of the suction grille	<p data-bbox="153 965 464 1093">1 Release the 3 hooks at the upper first, and then, 3 hooks at the middle.</p>  <p style="text-align: right;">(R9586)</p> <p data-bbox="153 1272 464 1332">2 Release the 3 hooks at the bottom.</p>  <p style="text-align: right;">(R9587)</p>	<p>■ The hooks are secured in the clearances of the heat exchanger fins.</p>
2. Removal of the top panel	<p data-bbox="153 1693 448 1794">1 Remove the 7 screws and remove the top panel.</p>  <p style="text-align: right;">(R9588)</p>	

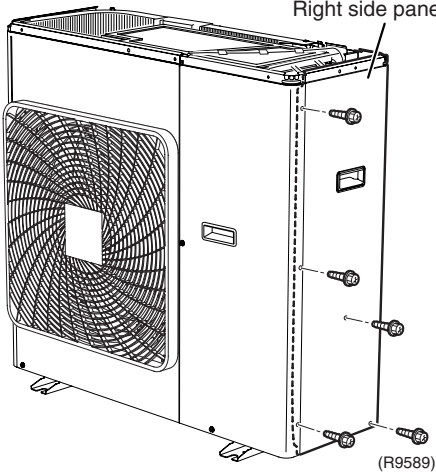
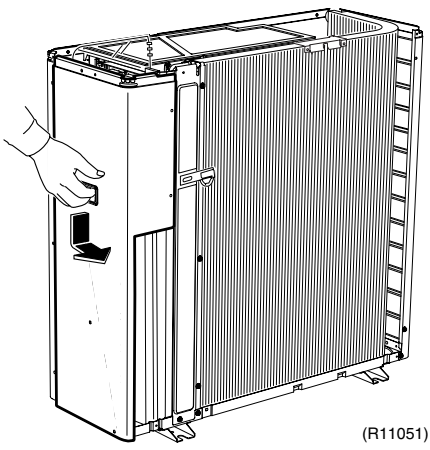
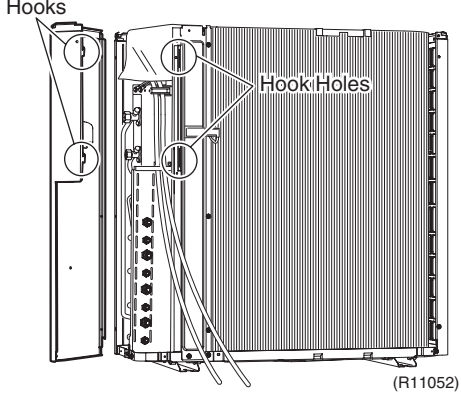
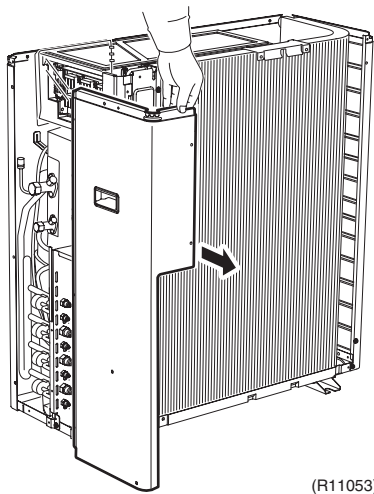
Step	Procedure	Points
3. Removal of the right side panel		
1 Remove the 5 screws.	 <p>Right side panel</p> <p>(R9589)</p>	
2 Slide the right side panel downward to release 2 hooks on the back side.	 <p>(R11051)</p>  <p>Hooks</p> <p>Hook Holes</p> <p>(R11052)</p>  <p>(R11053)</p>	
3 Remove the right side panel.		

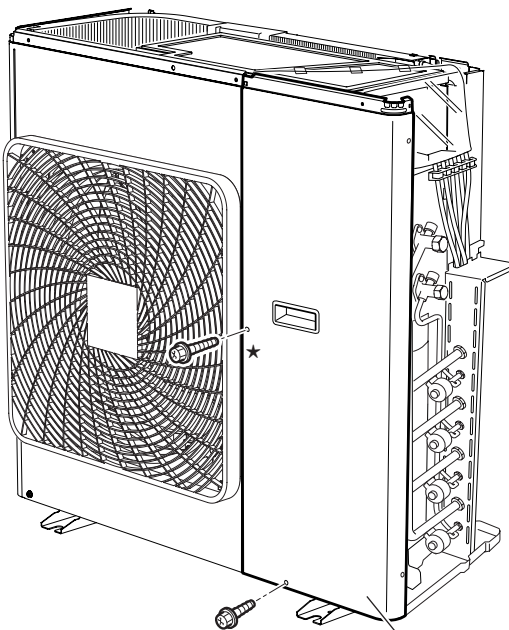
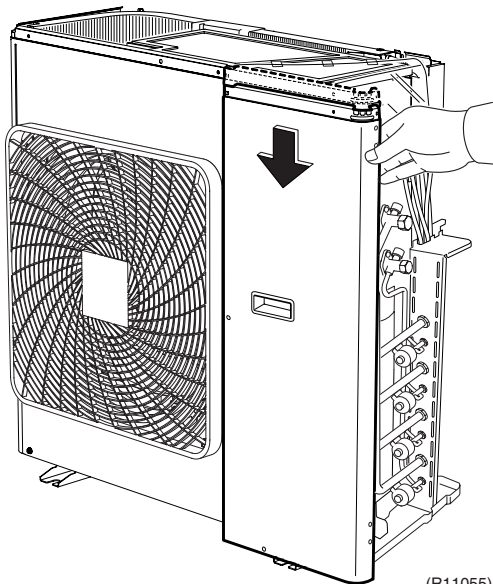
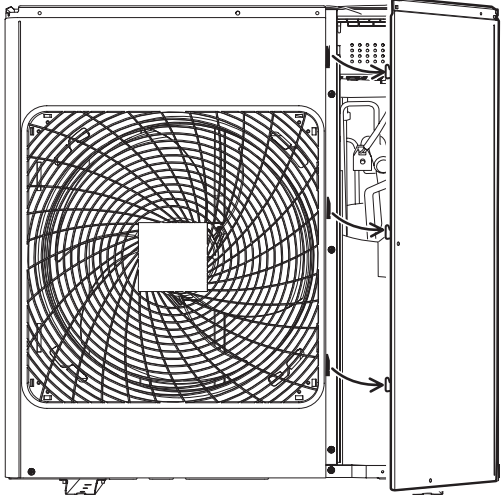
Step	Procedure	Points
4. Removal of the front panel (2)		★ M5×20
1	<p data-bbox="199 280 454 313">Remove the 2 screws.</p>  <p data-bbox="869 873 1045 929">Front panel (2) (R11054)</p>	
2	<p data-bbox="199 952 454 1041">Slide the front panel (2) downward to release the 3 hooks.</p>  <p data-bbox="957 1545 1029 1568">(R11055)</p>  <p data-bbox="965 2094 1029 2116">(R9594)</p>	

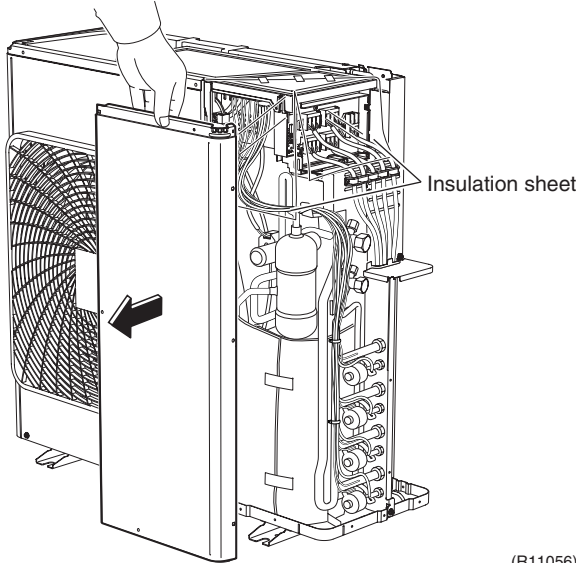
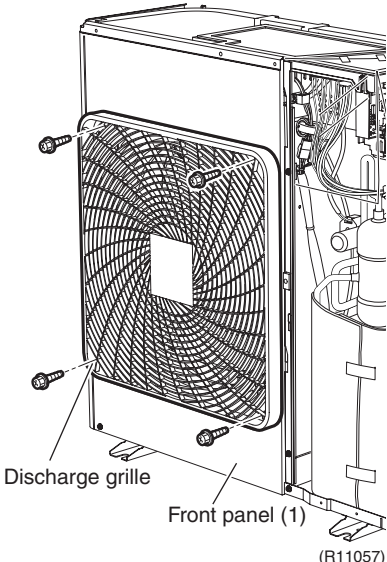
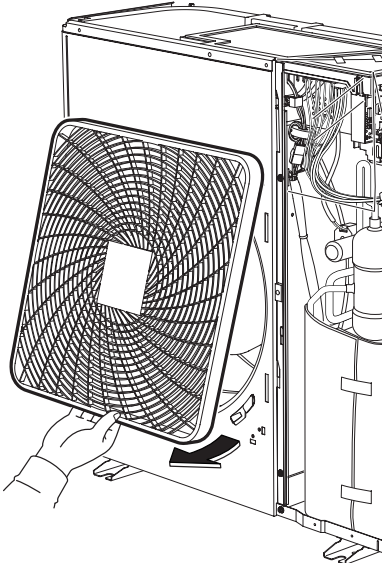
Step	Procedure	Points
3	<p>Remove the front panel (2).</p>  <p style="text-align: right;">(R11056)</p>	<ul style="list-style-type: none"> ■ The insulation sheet is inserted between the front panel (2) and the electrical box.
5. Removal of the front panel (1)	<p>1 Remove the 4 screws on the discharge grille.</p>  <p style="text-align: right;">(R11057)</p> <p>2 Pull the bottom of the discharge grille toward yourself.</p>  <p style="text-align: right;">(R11058)</p>	<ul style="list-style-type: none"> ■ Remove the discharge grille and outdoor fan first to remove the front panel (1).

Step	Procedure	Points
3	Remove the fixing nut and remove the outdoor fan.	Fan fixing nut : M8
4	Remove the 2 screws on the partition plate (1).	
5	Remove the 2 screws at the bottom left of the front.	

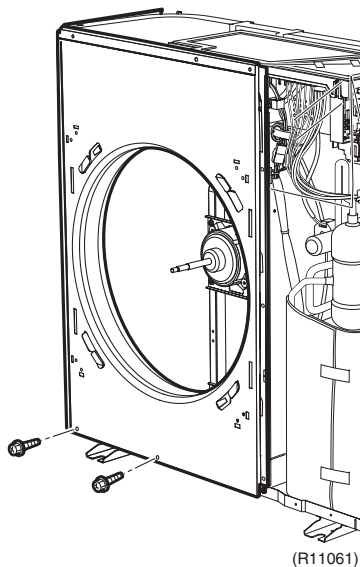
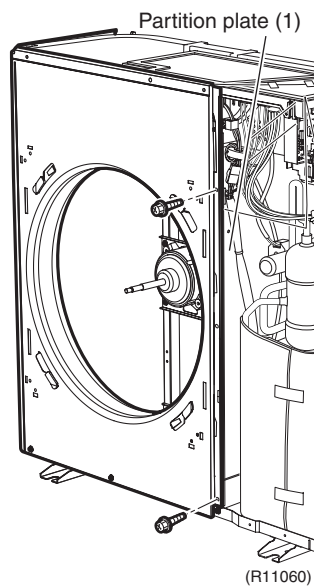
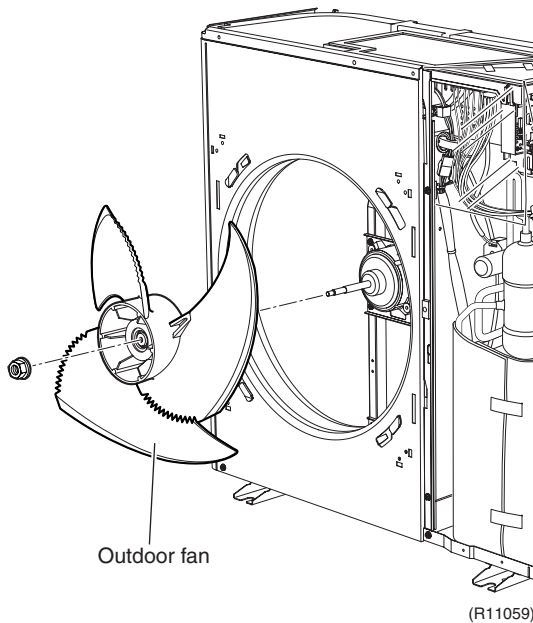

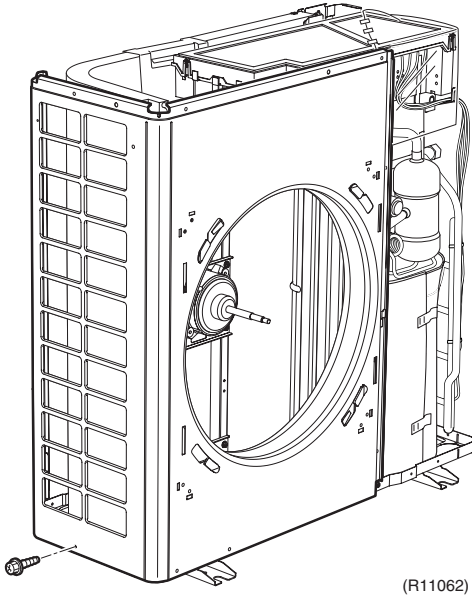
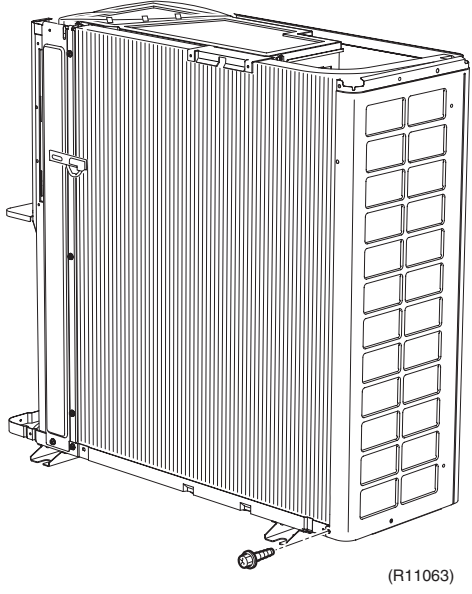
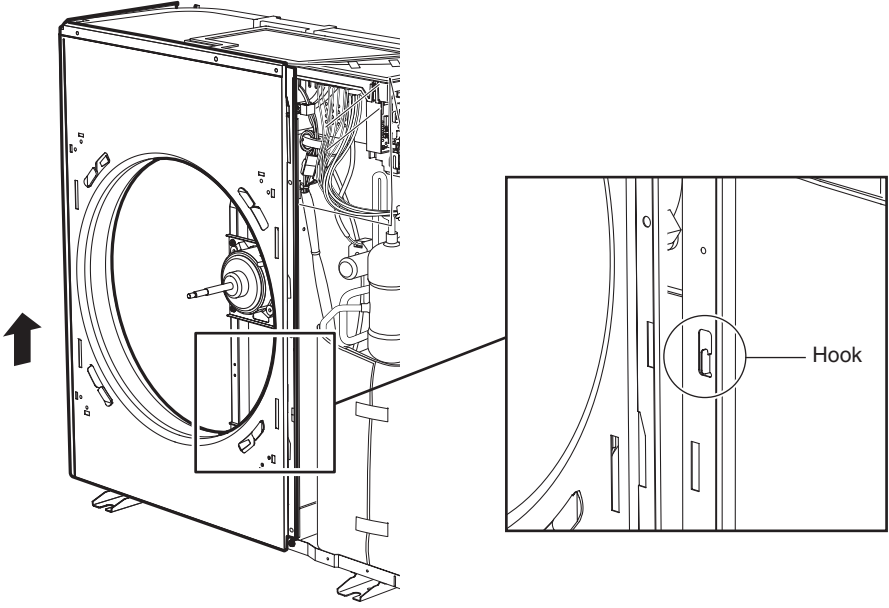
Step	Procedure	Points
6	Remove the screw at the bottom of the left side.	
	 <p>(R11062)</p>	
7	Remove the screw at the bottom of the back side.	
	 <p>(R11063)</p>	
8	The front panel (1) is provided with a hook on its front. Lift the front panel (1) off position to remove it.	
	 <p>(R18409)</p>	

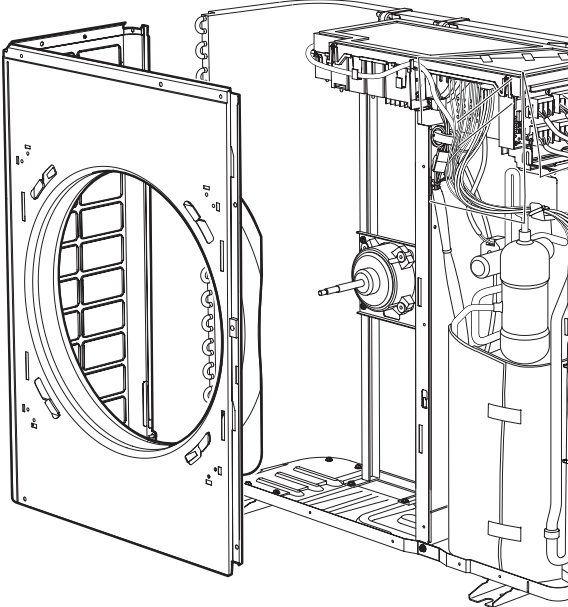
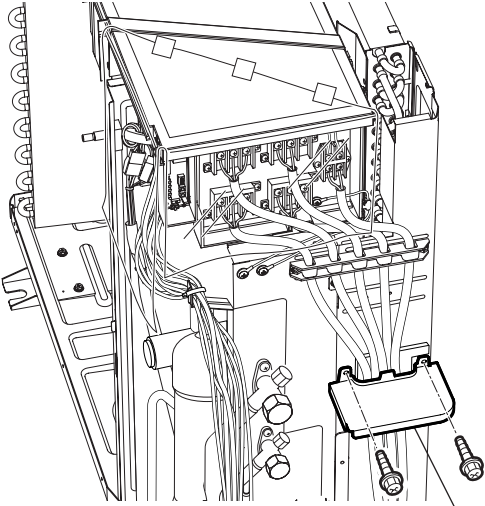
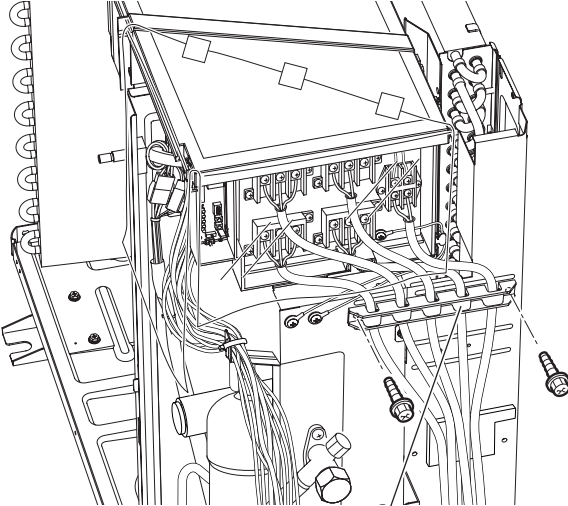
Step	Procedure	Points
9	<p>Remove the front panel (1).</p>  <p>(R11065)</p>	
6.	<p>Removal of the rear panel</p> <p>1 Remove the 2 screws on the partition plate (2).</p> <p>2 Lift up slightly and remove the partition plate (2).</p>  <p>Partition plate (2) (R11066)</p> <p>3 Remove the 2 screws on the wire fixing plate.</p>  <p>Wire fixing plate (R11067)</p>	

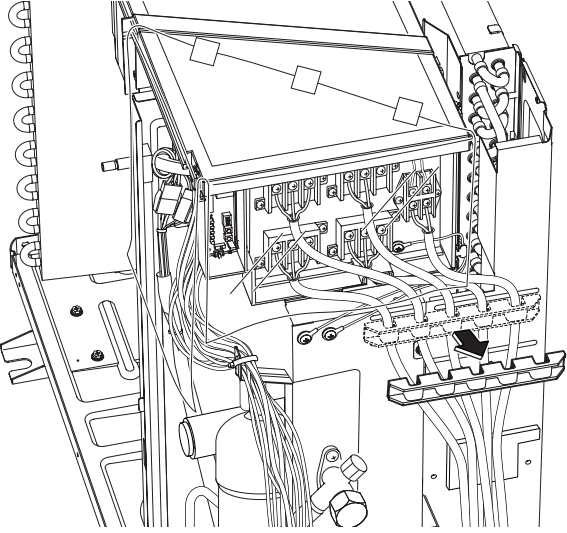
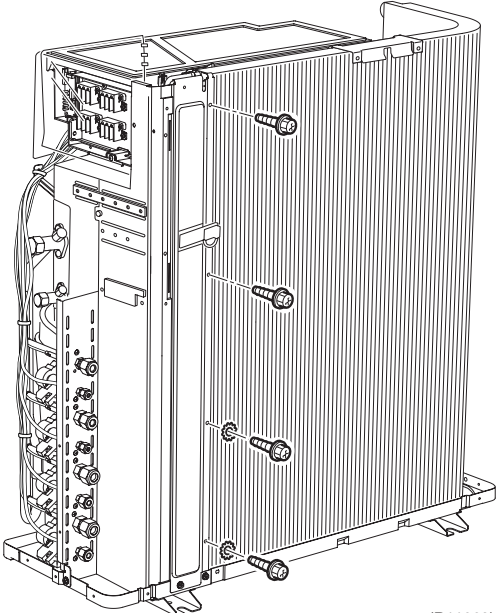
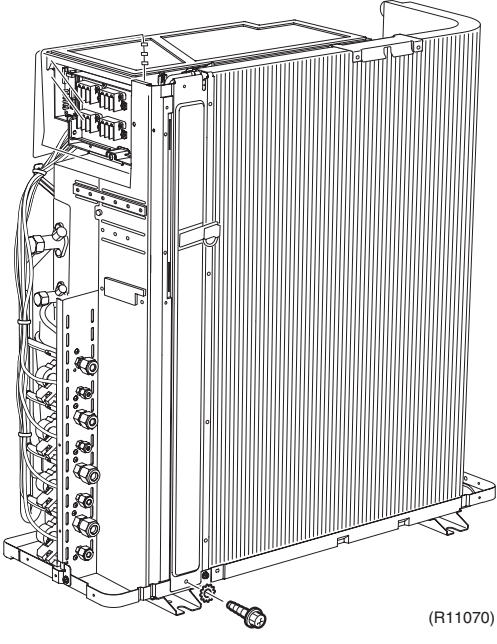
Step	Procedure	Points
4	<p data-bbox="199 219 459 277">Remove the wire fixing plate.</p>  <p data-bbox="986 775 1054 797">(R11068)</p>	
5	<p data-bbox="199 804 448 862">Remove the 4 screws on the rear panel.</p>  <p data-bbox="963 1431 1032 1453">(R11069)</p>	
6	<p data-bbox="199 1462 459 1520">Remove the 1 screw from the bottom frame.</p>  <p data-bbox="963 2089 1032 2112">(R11070)</p>	

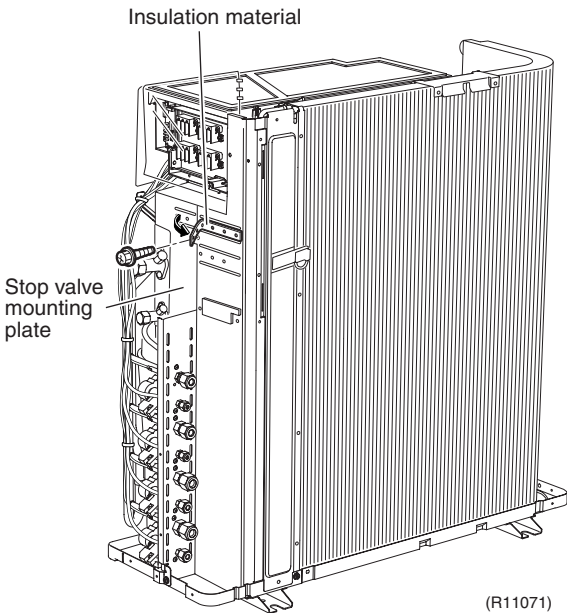
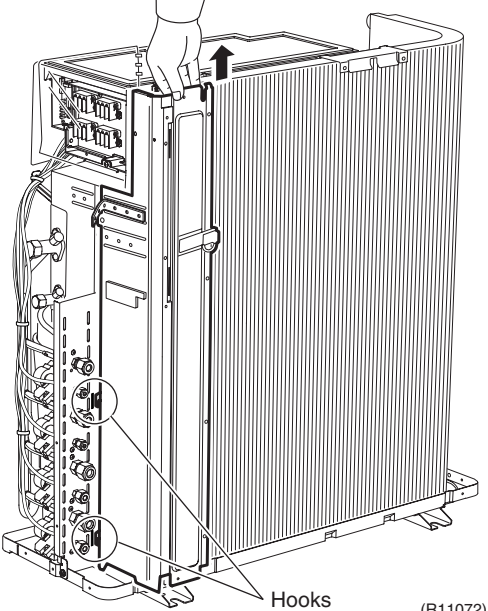
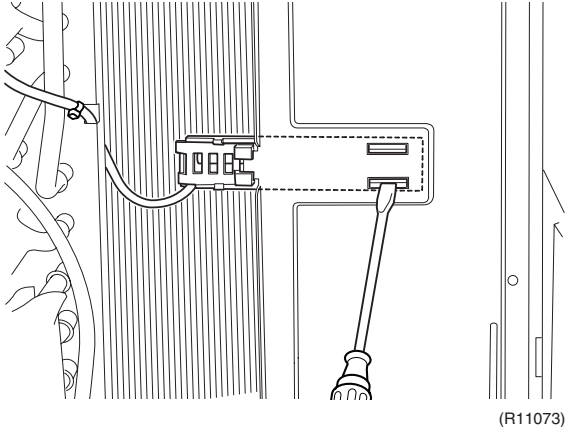
Step	Procedure	Points
7	Remove the 1 screw from the stop valve mounting plate. Peel off a half of the insulation material.	
	 <p>Insulation material</p> <p>Stop valve mounting plate</p> <p>(R11071)</p>	
8	Lift the rear panel upward to release the 2 hooks.	
	 <p>Hooks</p> <p>(R11072)</p>	
9	Push the hooks of the outdoor temperature thermistor holder from inner-side.	
	 <p>(R11073)</p>	

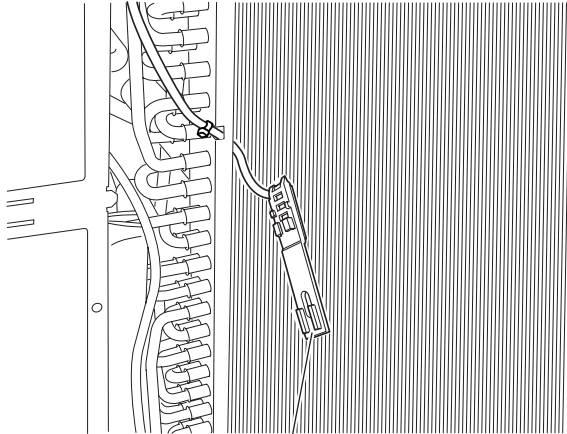
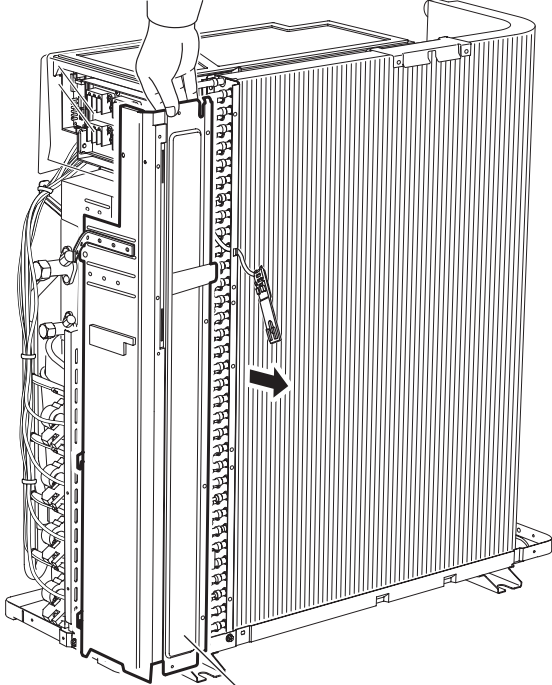
Step		Procedure	Points
10	The outdoor temperature thermistor holder is now released.	 <p data-bbox="662 719 1066 772">Outdoor temperature thermistor holder (R11074)</p>	
11	Remove the rear panel.	 <p data-bbox="770 1525 1066 1556">Rear panel (R11075)</p>	

2. Removal of Fan Motor

Procedure



Warning Be sure to wait 10 minutes or more after turning off all power supplies before disassembling work.

Step	Procedure	Points
1	Disconnect the connector for fan motor (S70) and release the ferrite core attached to the electrical box with clamp.	<ul style="list-style-type: none"> ■ When reassembling, insert the clamp into the small hole.
2	The illustration shows arrangement of the fan motor lead wire.	<ul style="list-style-type: none"> ■ Fix the ferrite core at where the tension does not pull the PCB ASSY when connecting the connectors.
3	Cut the clamps at 2 locations.	

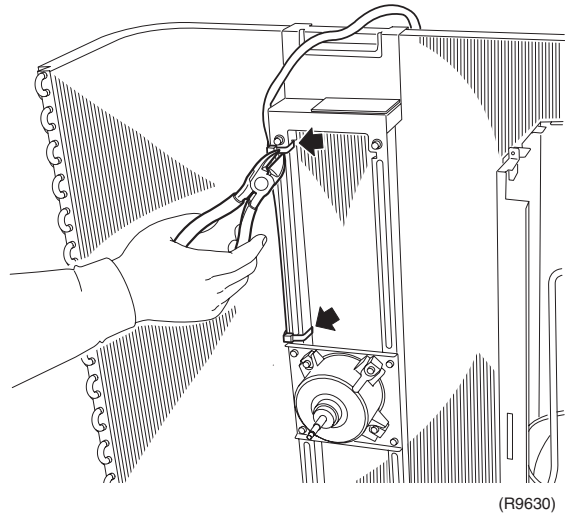
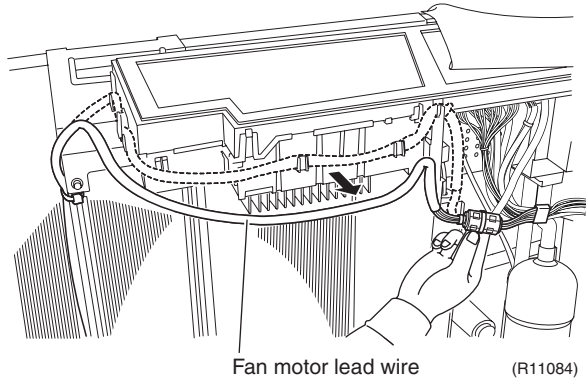
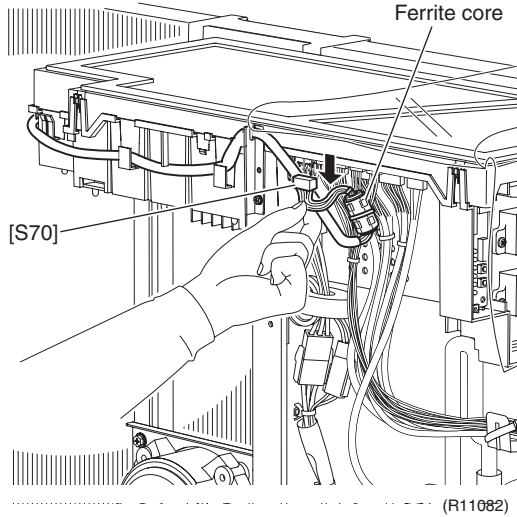

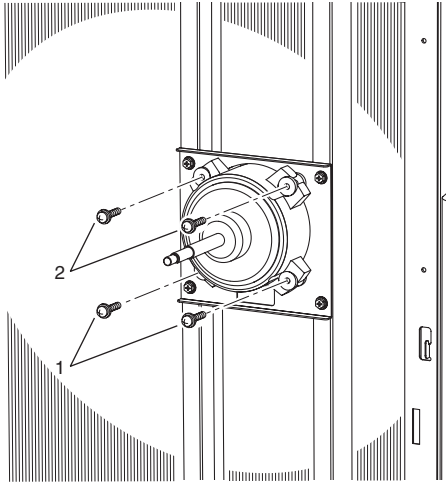
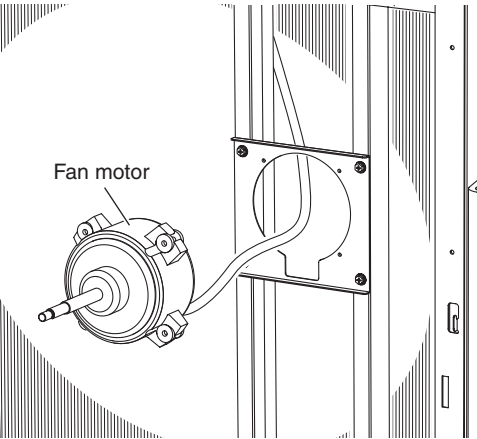
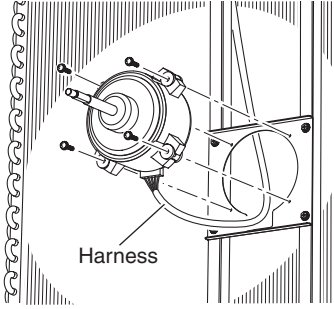
Step		Procedure	Points
4	Remove the 2 screws at the bottom first.	 <p>(R11076)</p>	<ul style="list-style-type: none"> ■ Be sure to remove the bottom screws first. If the top screws are removed first, the fan motor, the center of gravity of which is toward the front, may tilt down or fall, getting you injured.
5	Next, remove the 2 top screws.	 <p>(R11077)</p>	<ul style="list-style-type: none"> ■ When reassembling, be sure to place the wire harness lower.  <p>(R11078)</p>
6	Remove the fan motor.		

3. Removal of Electrical Box

Procedure

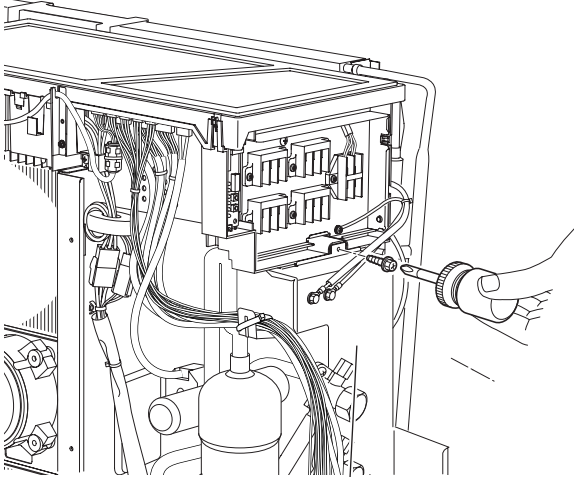
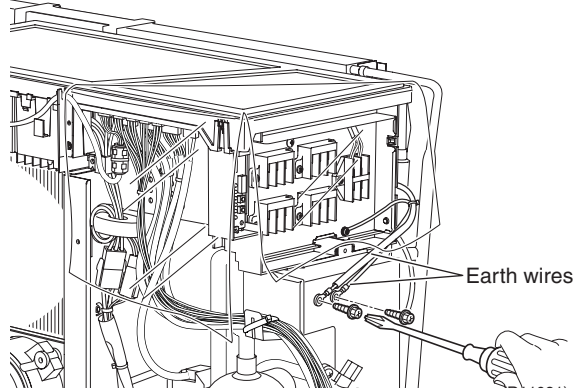
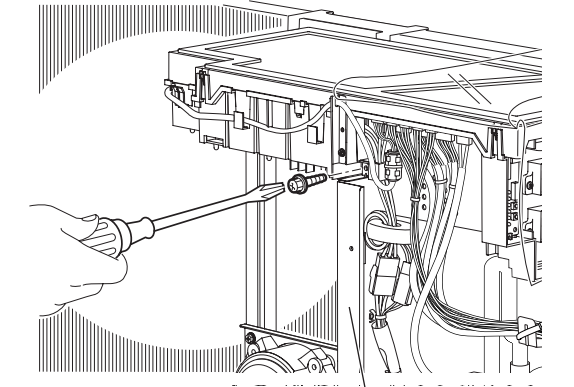

Warning Be sure to wait 10 minutes or more after turning off all power supplies before disassembling work.

Step	Procedure	Points
1	Remove the 1 screw from the stop valve mounting plate.	
	 <p style="text-align: center;">Stop valve mounting plate (R11079)</p>	
2	Remove the 2 screws to detach the earth wires.	
	 <p style="text-align: center;">Earth wires (R11081)</p>	
3	Remove the 1 screw on the partition plate.	
	 <p style="text-align: center;">Partition plate (R11080)</p>	

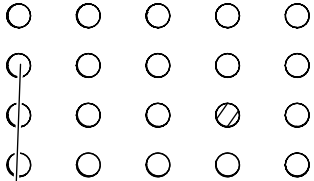
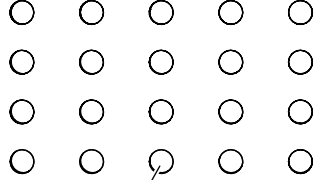
Step	Procedure	Points
4	Disconnect the connector for fan motor (S70) and release the ferrite core attached to the electrical box with clamp.	<ul style="list-style-type: none"> ■ When reassembling, insert the clamp into the small hole.  <p>Fixing position for ferrite core of fan motor (R11083)</p>
5	The illustration shows arrangement of the fan motor lead wire.	<ul style="list-style-type: none"> ■ Fix the ferrite core at where the tension does not pull the PCB ASSY when connecting the connectors.
6	Disconnect the 4 connectors for electronic expansion valve coil and detach the clamp. S20: room A (blue) S21: room B (yellow) S22: room C (white) S23: room D (red)	<ul style="list-style-type: none"> ■ When reassembling, insert the clamp into the small hole.  <p>Fixing position for electronic expansion valve coil connectors (R11086)</p>
7	Disconnect the connector for four way valve coil (S80).	

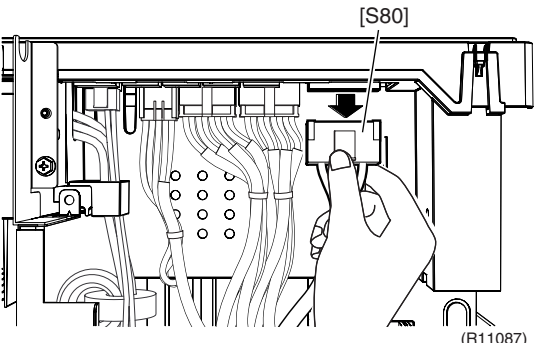
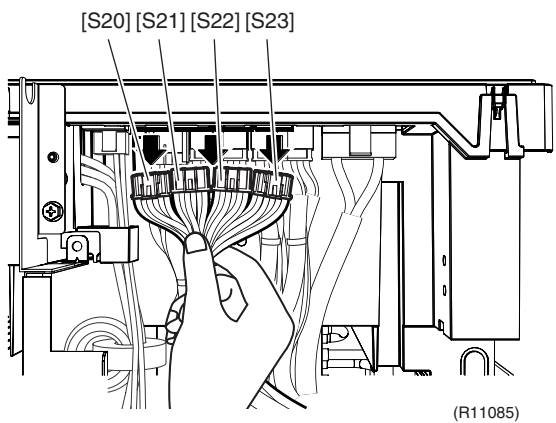
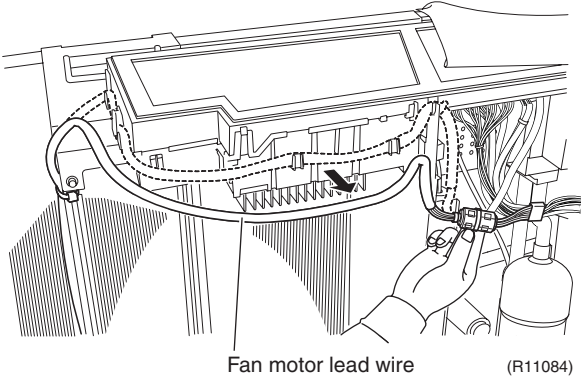
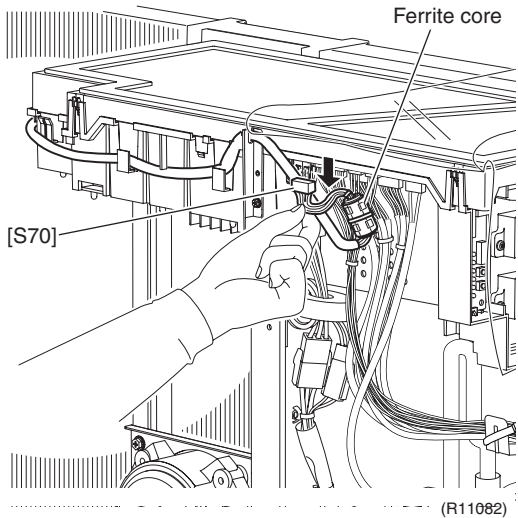

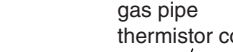
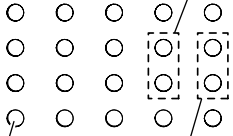
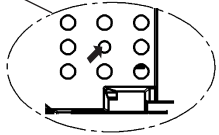
Step	Procedure	Points
8	<p>Disconnect the 2 connectors and detach the 2 clamps. S92: gas pipe thermistor connector S93: liquid pipe thermistor connector</p>	<p>■ When reassembling, insert the clamp into the small hole.</p> <div style="display: flex; justify-content: space-around; align-items: center;"> <div style="text-align: center;">  <p>gas pipe thermistor connector</p> </div> <div style="text-align: center;">  <p>liquid pipe thermistor connector</p> </div> </div> <p>thermistor connector</p>
9	<p>Disconnect the connector for thermistor (S90) and detach the clamp. S90: thermistor connector (outdoor temperature, heat exchanger, discharge pipe)</p>	
10	<p>The wire harness is hooked under the electrical box. Unhook it and pull out the clamp.</p>	<p>■ When reassembling, insert the clamp into the small hole.</p>
11	<p>The wire harness for the compressor is attached to the partition plate (1) by the clamp.</p>	

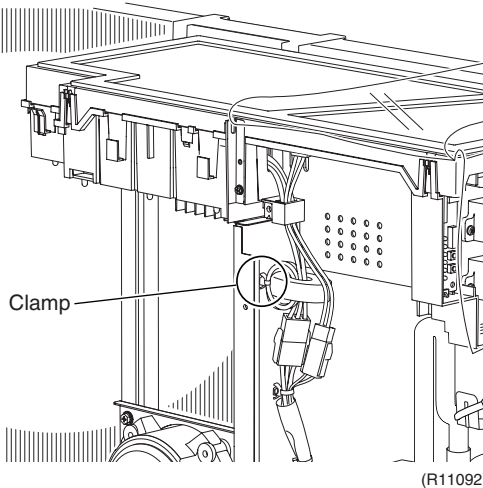
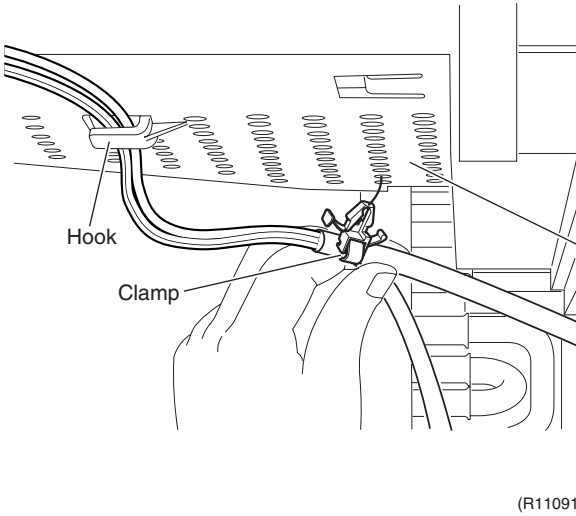
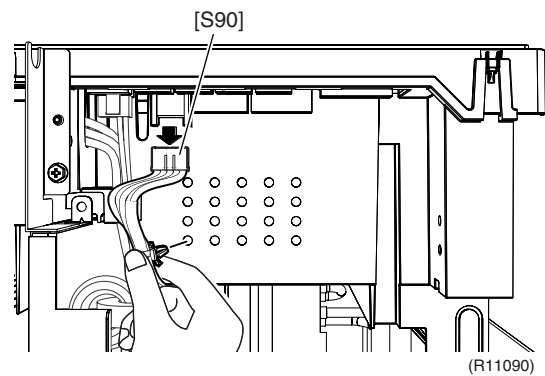
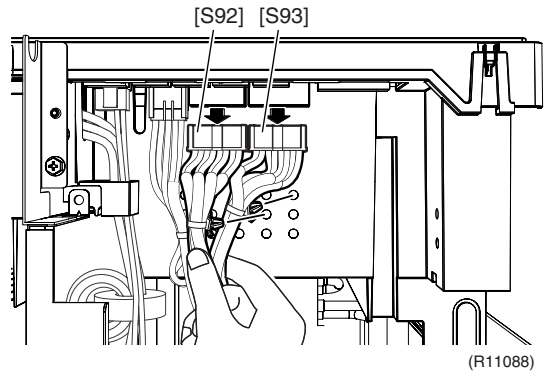

Step	Procedure	Points
12	Pull out the clamp.	■ Detach the clamp.
13	Disconnect the relay connector of the overload protector (OL) and the compressor.	
14	Slide the electrical box leftward to release the hook on the right side of the box.	
15	Lift up the electrical box to remove it.	

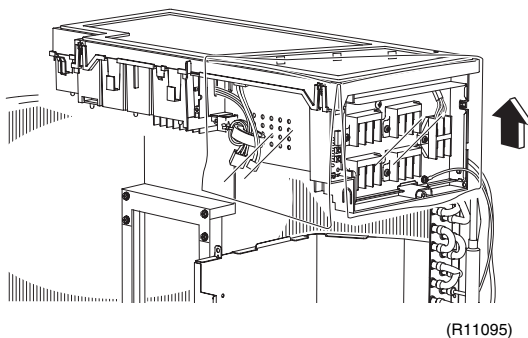
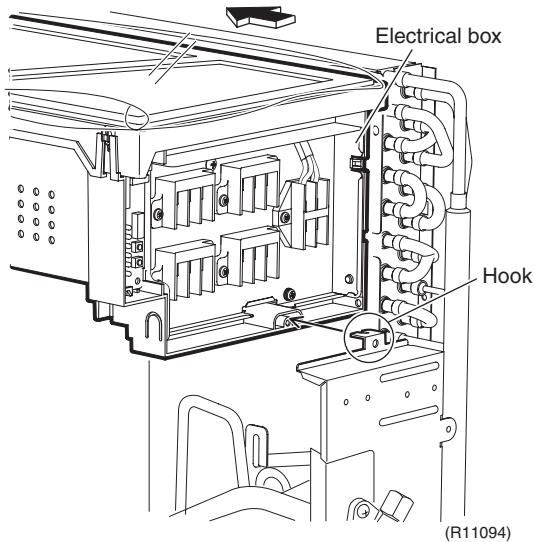
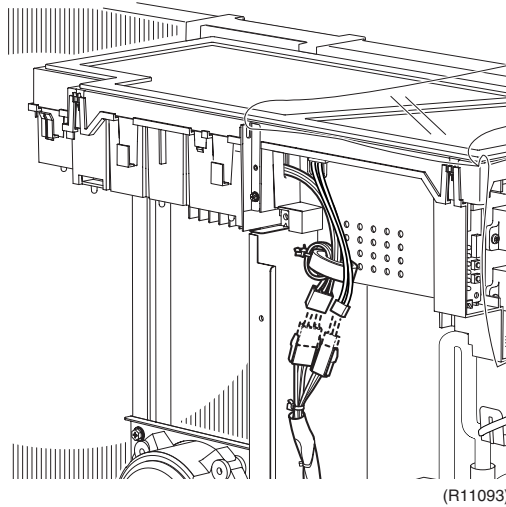
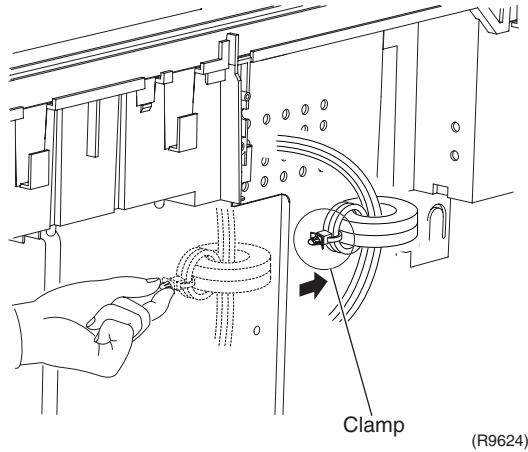

4. Removal of PCBs

Procedure



Warning Be sure to wait 10 minutes or more after turning off all power supplies before disassembling work.

Step	Procedure	Points
<p>■ Remove the electrical box.</p>		
<p>1. Removal of the PCB</p>		
<p>1 Turn over the insulation sheet. Peel off the filament tape.</p>		
<p>2 Unhook the 4 hooks and remove the electrical box cover.</p>		
<p>3 Disconnect the connectors (S52, S102) from the service monitor PCB.</p>		

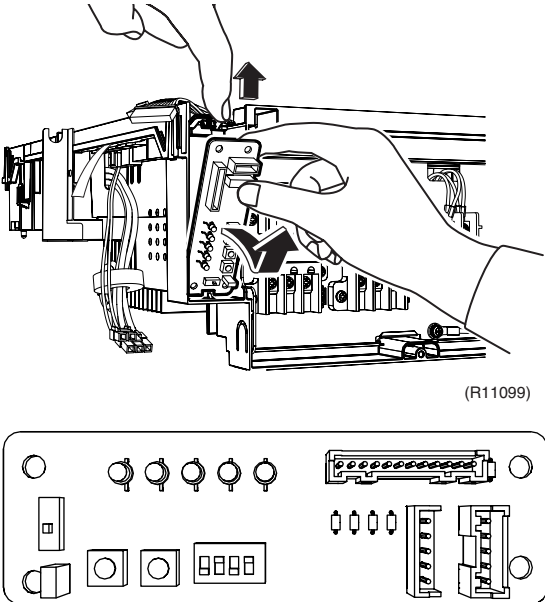
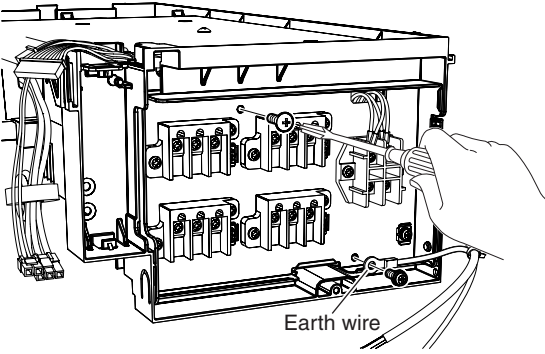
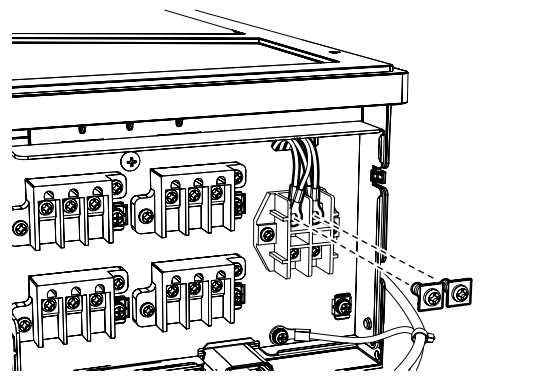
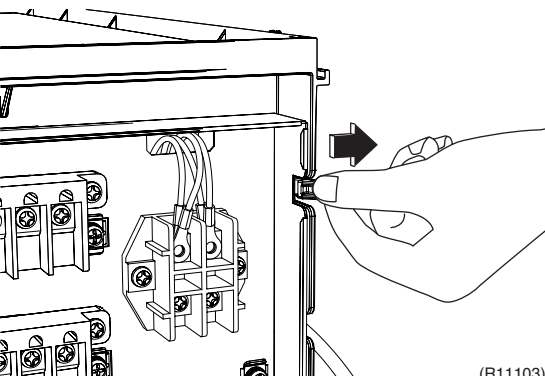
Step	Procedure	Points
4	Release the hooks and remove the service monitor PCB.	
	 <p>(R11099)</p> <p>(R11100)</p>	
5	Remove the 2 screws of the terminal board and the earth wire.	
	 <p>Earth wire</p> <p>(R11101)</p>	
6	Remove the 2 screws of the power supply terminal.	
	 <p>(R11102)</p>	
7	Release the hook on the right.	
	 <p>(R11103)</p>	

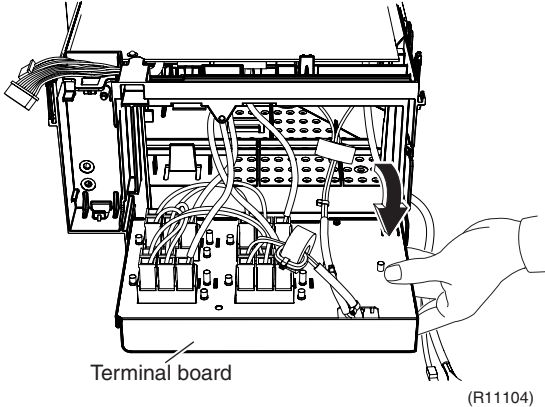
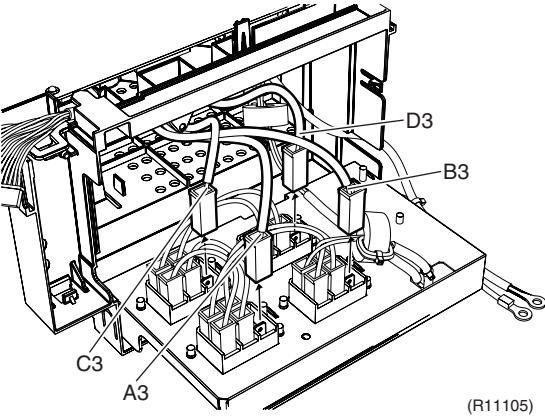
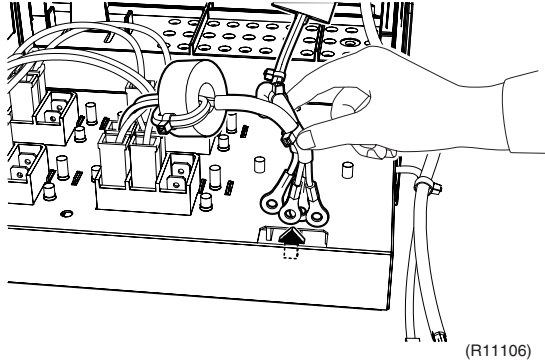
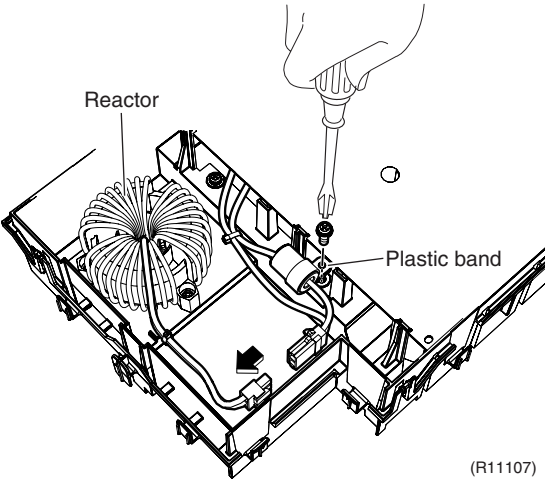
Step	Procedure	Points
8	Open the terminal board.	
	 <p style="text-align: center;">Terminal board</p> <p style="text-align: right;">(R11104)</p>	
9	Disconnect the 4 connectors.	<p>A3: Red B3: Yellow C3: Blue D3: Orange</p>
	 <p style="text-align: right;">(R11105)</p>	
10	Release the 2 wire harnesses from the terminal board.	
	 <p style="text-align: right;">(R11106)</p>	
11	Disconnect the relay connector for the reactor. Remove the screw and remove the plastic band.	
	 <p style="text-align: right;">(R11107)</p>	

Step	Procedure	Points
12	Remove the 3 screws of the main PCB.	
13	Release the 4 hooks.	
14	Disconnect the 3 connectors for the compressor harnesses.	
15	Lift up and remove the main PCB.	

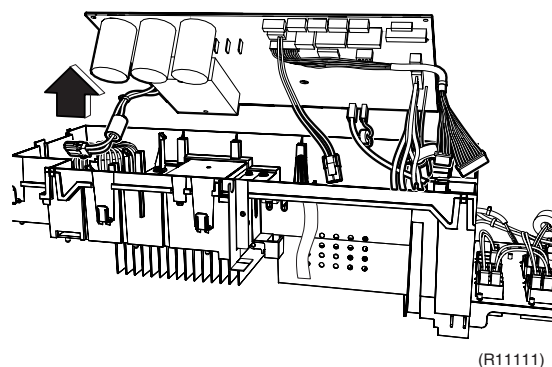
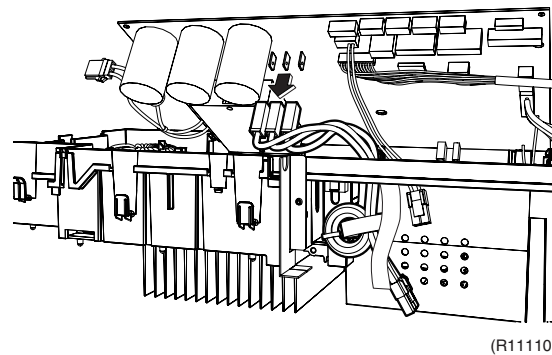
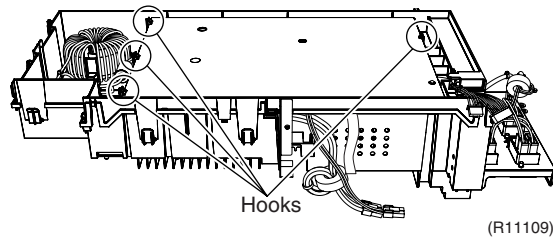
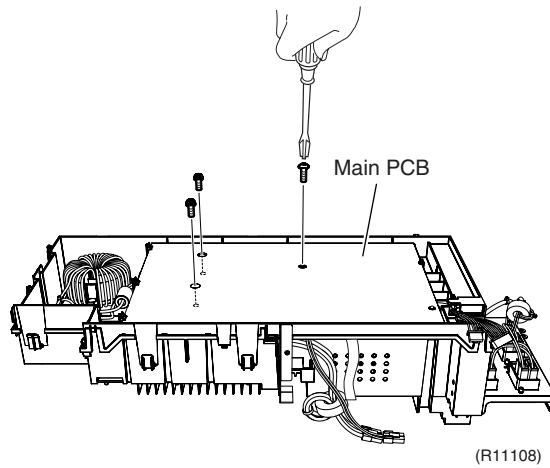

Step	Procedure	Points
16	Remove the 3 screws of the reactor and remove it.	
17	Remove the 3 screws of the radiation fin and remove it.	

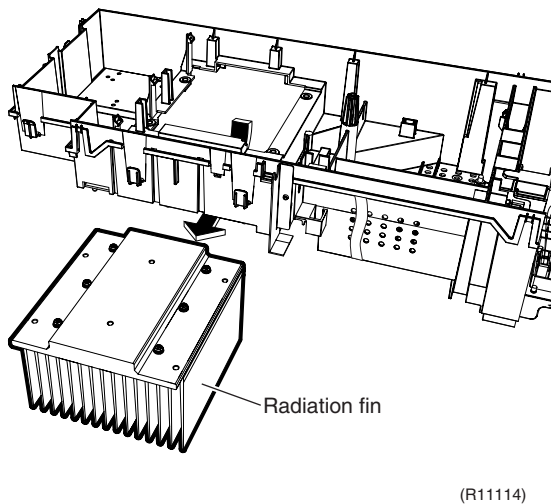
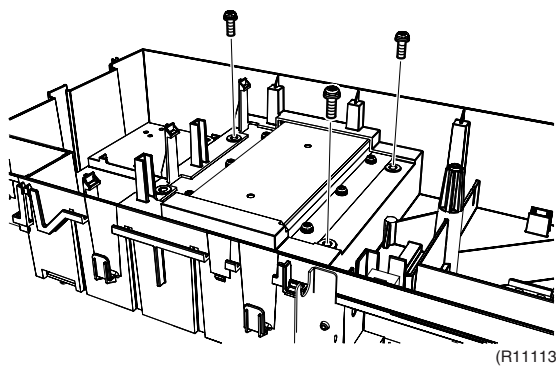
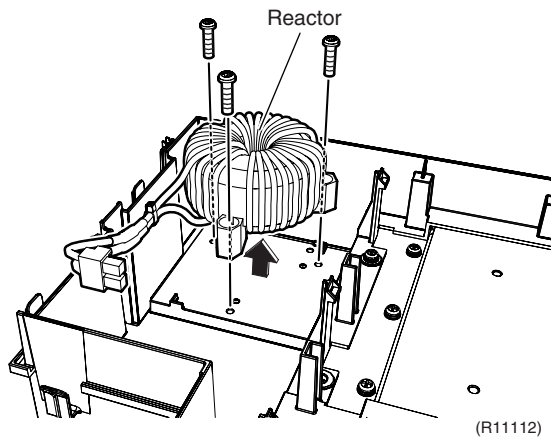

5. Removal of Coils / Thermistors

Procedure

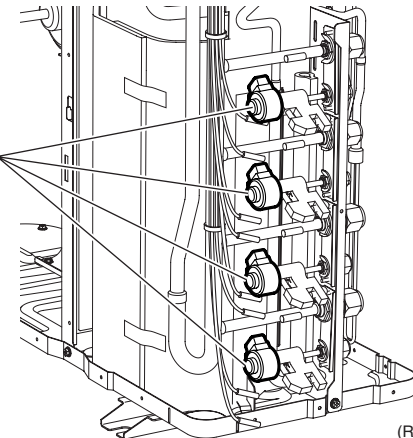
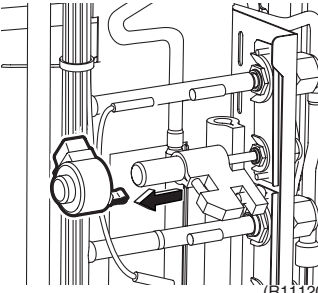
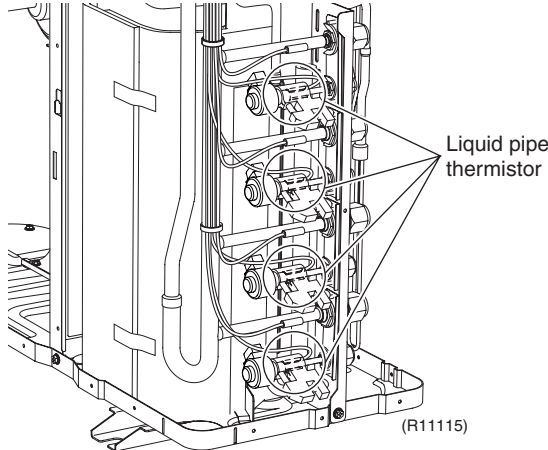
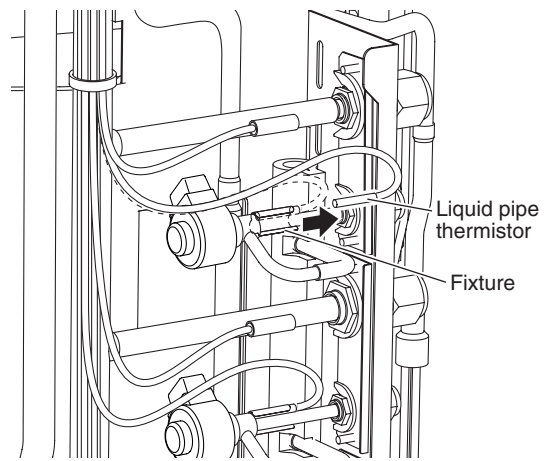

Warning Be sure to wait 10 minutes or more after turning off all power supplies before disassembling work.

Step	Procedure	Points
1. Removal of the electronic expansion valve coils 1 Pull out the electronic expansion valve coils.	 <p>Electronic expansion valve coils</p> <p>(R11119)</p>  <p>(R11120)</p>	
2. Removal of the thermistors 1 Peel off the putty and pull out the liquid pipe thermistors.	 <p>Liquid pipe thermistor</p> <p>(R11115)</p>  <p>Liquid pipe thermistor</p> <p>Fixture</p> <p>(R11116)</p>	<ul style="list-style-type: none"> ■ Be careful not to lose the fixtures.

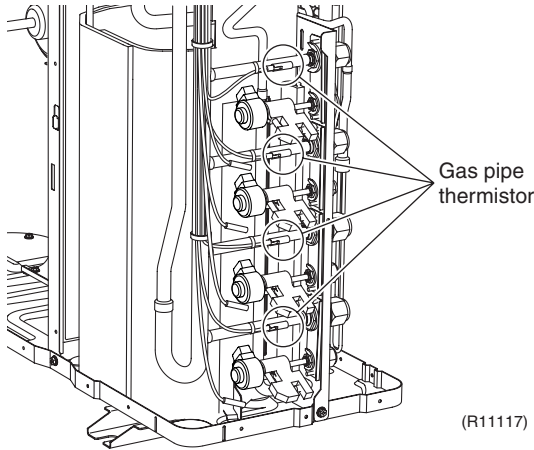
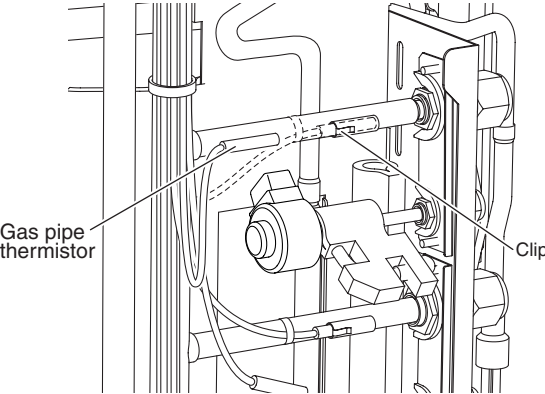
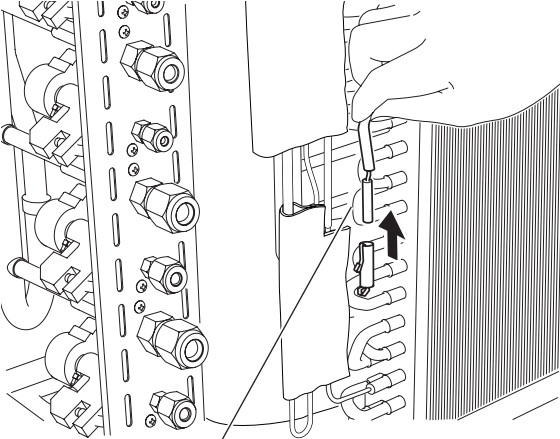
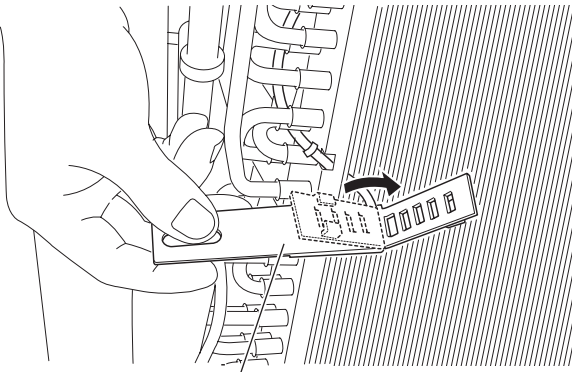
Step	Procedure	Points
2	<p data-bbox="199 215 432 275">Pull out the gas pipe thermistors.</p>  <p data-bbox="943 398 1043 443">Gas pipe thermistor</p> <p data-bbox="967 645 1043 674">(R11117)</p>  <p data-bbox="501 958 601 1003">Gas pipe thermistor</p> <p data-bbox="1018 981 1054 1003">Clip</p> <p data-bbox="986 1133 1054 1162">(R11118)</p>	<ul style="list-style-type: none"> <li data-bbox="1093 712 1417 772">■ Be careful not to lose the clips.
3	<p data-bbox="199 1167 448 1234">Pull out the heat exchanger thermistor.</p>  <p data-bbox="703 1644 959 1666">Heat exchanger thermistor</p> <p data-bbox="991 1644 1054 1673">(R11121)</p>	
4	<p data-bbox="199 1682 459 1816">At the back side, open the outdoor temperature thermistor holder.</p>  <p data-bbox="596 2092 963 2114">Outdoor temperature thermistor holder</p> <p data-bbox="1002 2092 1070 2121">(R11270)</p>	

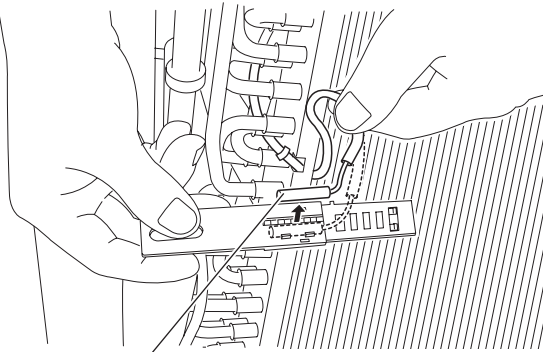
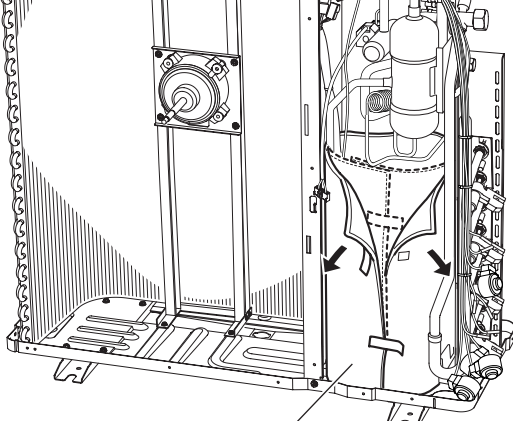
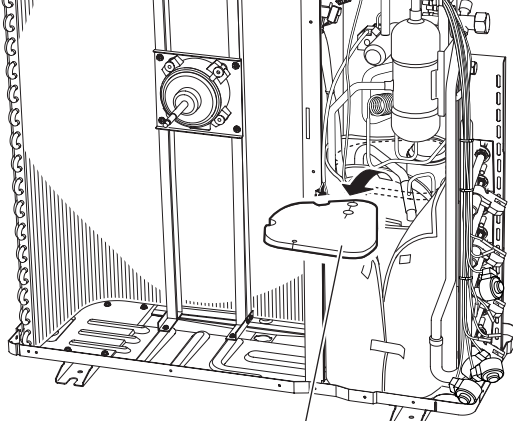
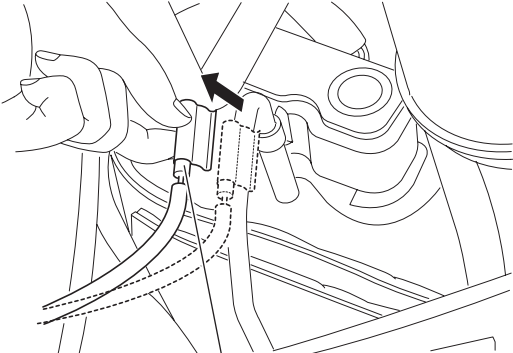
Step	Procedure	Points
5	Release the outdoor temperature thermistor.	
		
	Outdoor temperature thermistor (R11271)	
6	Slightly open the sound blanket (outer).	
		
	Sound blanket (outer) (R11122)	
7	Remove the sound blanket (top upper).	
		
	Sound blanket (top upper) (R11123)	
8	Remove the discharge pipe thermistor.	
		
	Discharge pipe thermistor (R9635)	

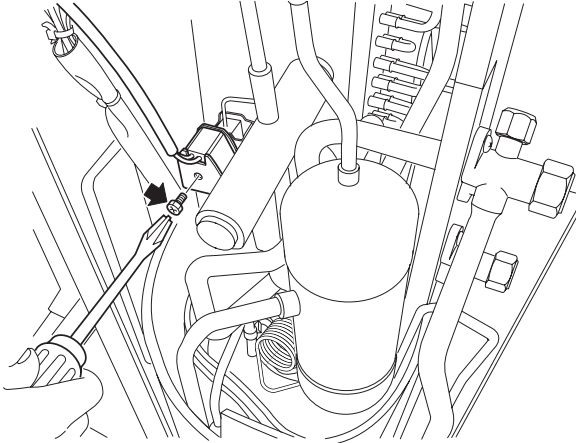
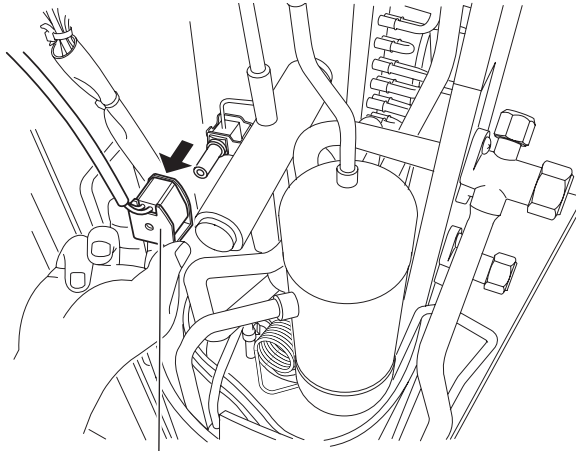
Step	Procedure	Points
3.	Removal of the four way valve coil	
1	Remove the screw.  <p style="text-align: right;">(R11124)</p>	
2	Remove the four way valve coil.  <p style="text-align: center;">Four way valve coil</p> <p style="text-align: right;">(R11125)</p>	

6. Removal of Sound Blanket

Procedure

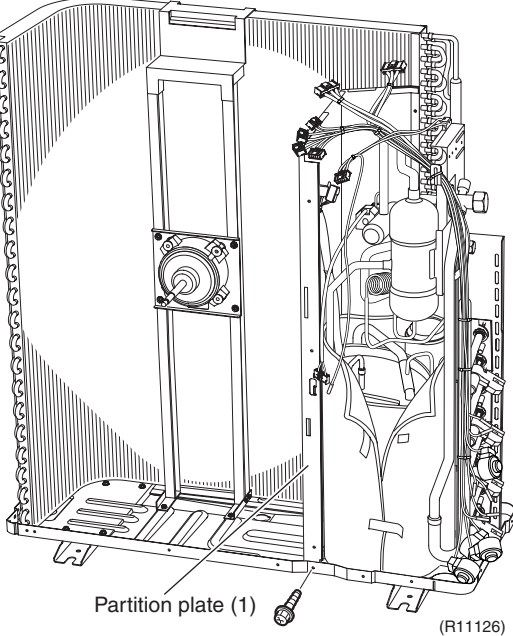
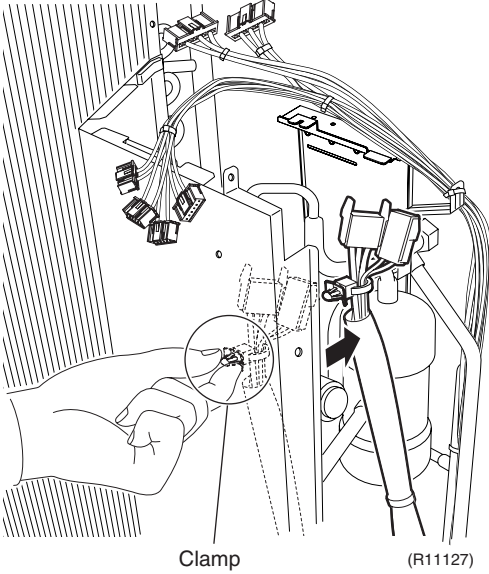
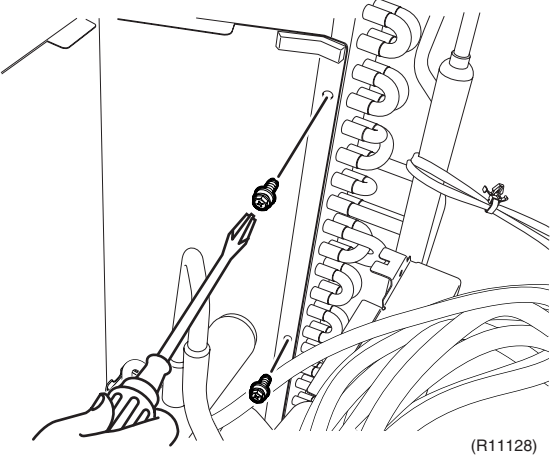

Warning Be sure to wait 10 minutes or more after turning off all power supplies before disassembling work.

Step	Procedure	Points
1	Remove the screw from the partition plate (1).	
		
2	Release the clamp.	
		
3	Remove the 2 screws.	
		

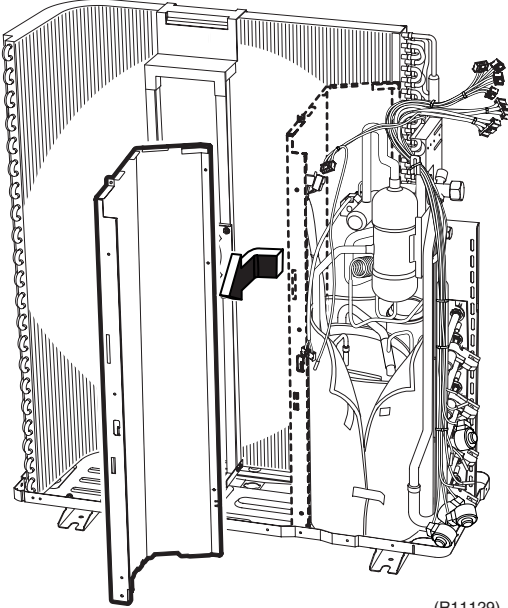
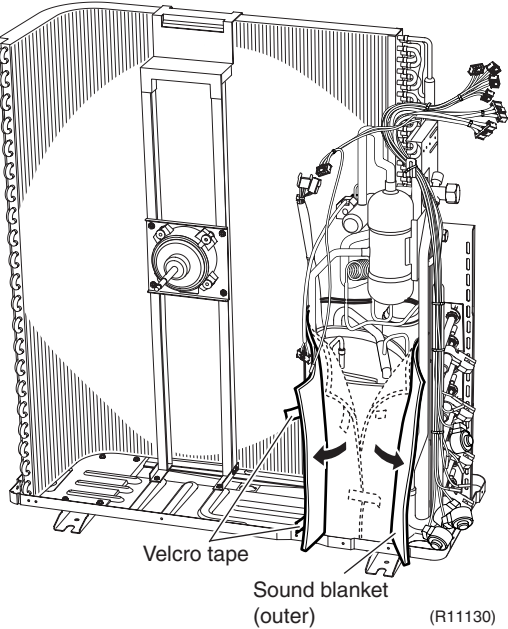
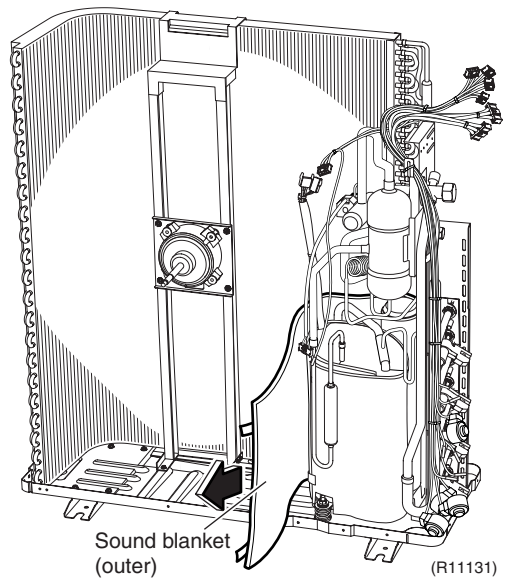
Step	Procedure	Points
4	Remove the partition plate (1).	
	 <p style="text-align: right;">(R11129)</p>	
5	Open the sound blanket (outer).	
	 <p style="text-align: center;">Velcro tape</p> <p style="text-align: center;">Sound blanket (outer)</p> <p style="text-align: right;">(R11130)</p>	
6	Remove the sound blanket (outer).	<p>■ The sound blanket is fragile.</p>
	 <p style="text-align: center;">Sound blanket (outer)</p> <p style="text-align: right;">(R11131)</p>	

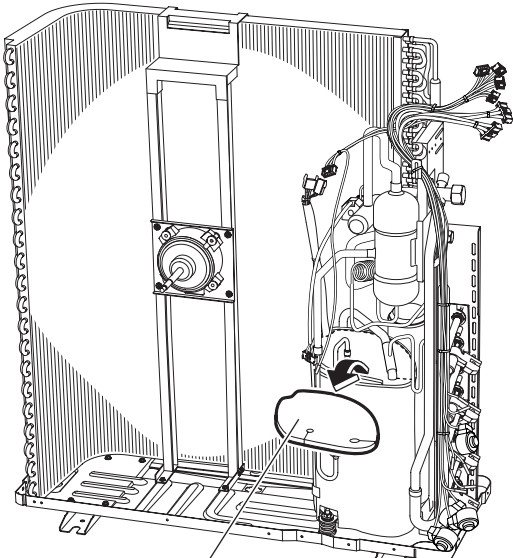
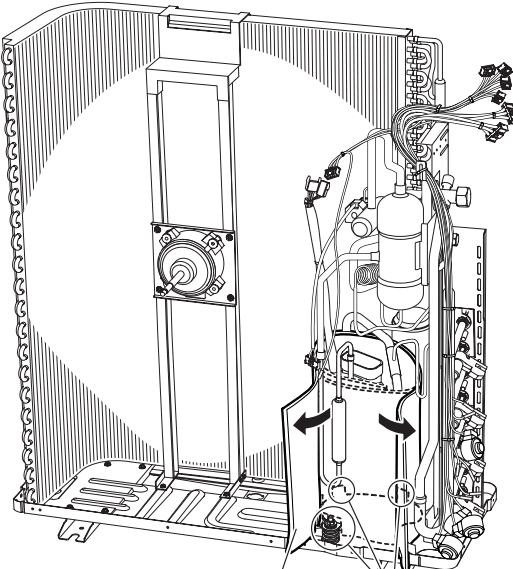
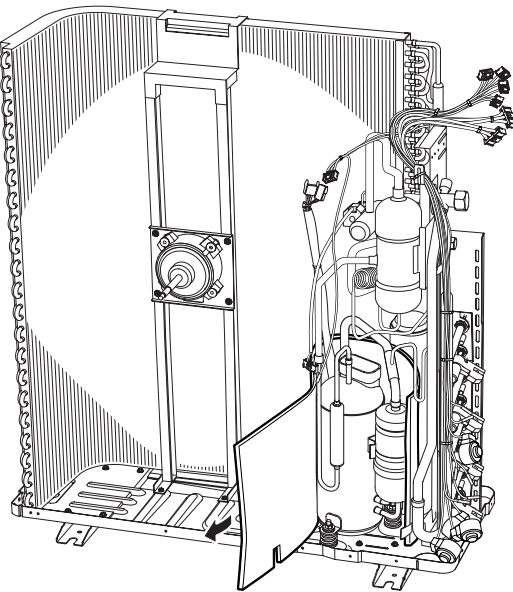
Step	Procedure	Points
7	Remove the sound blanket (top inner).	 <p data-bbox="611 786 1034 819">Sound blanket (top inner) (R11168)</p>
8	Open the sound blanket (inner).	 <p data-bbox="683 1413 1034 1496">Sound blanket (inner) Compressor mount (R11169)</p>
9	Remove the sound blanket (inner).	 <p data-bbox="954 2107 1034 2134">(R11170)</p>

■ The sound blanket is fragile. Be careful of the notches of the compressor mount (3 locations).

7. Removal of Compressor

Procedure



Warning Be sure to wait 10 minutes or more after turning off all power supplies before disassembling work.

Step	Procedure	Points
1	Remove the terminal cover.	<p style="text-align: right;">(R11171)</p>
2	Pull out the 3 lead wires with pliers.	<p>■ U:red, V:yellow, W:blue</p>
3	Remove the overload protector (OL).	<p style="text-align: right;">(R9471)</p>

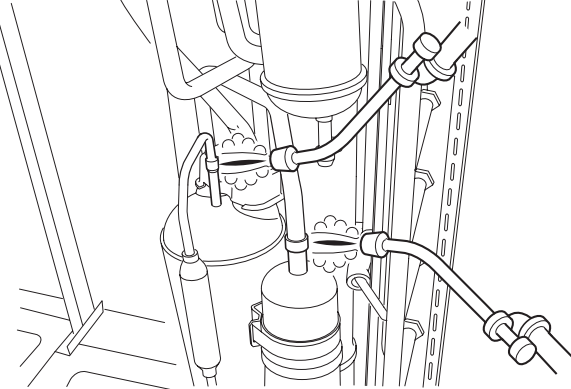
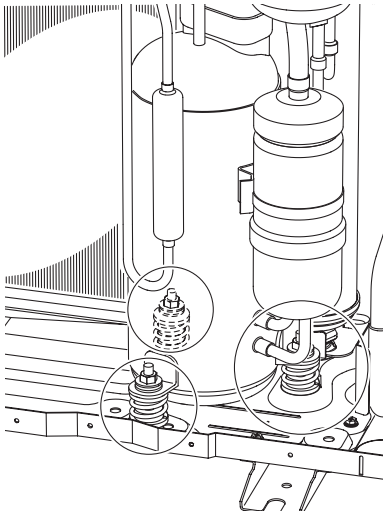
Step	Procedure	Points
4	<p>Heat up the brazed part and withdraw the piping with pliers.</p>  <p>(R11172)</p>	<p>Caution Be careful not to burn yourself with the pipes and other parts that are heated by the gas welding rod.</p> <p>Caution From the viewpoint of global environment protection, do not discharge the refrigerant gas in the atmosphere. Make sure to recover the refrigerant gas with the recovery system.</p>
5	<p>Warning If refrigerant gas leaks during the work, ventilate the room. (If the refrigerant gas is exposed to flame, noxious gas may be generated.)</p> <p>Remove the 3 nuts.</p>  <p>(R11173)</p>	<p>Reassembling precautions</p> <ol style="list-style-type: none"> 1. Use non-oxidizing brazing method. If nitrogen gas is not available, braze the parts quickly. 2. Avoid deterioration of the gaskets due to carbonization of oil inside the four way valve or thermal influence. For this purpose, wrap the four way valve with wet cloth. Splash water over the cloth against becoming too hot (keep it below 120°C). <p>■ In pulling the pipes, be careful not to over-tighten them with pliers. The pipes may get deformed.</p> <p>If the gas welding machine fails to remove the four way valve, take the steps below.</p> <ol style="list-style-type: none"> 1. Disconnect the brazed pipe sections that are easy to separate and join together later. 2. With a tube cutter, cut off the internal pipes to easily take out the four way valve. <p>Note: Never use a metal saw. The sawdust may come into the circuit.</p> <p>■ Provide a protective sheet or a steel plate so that the brazing flame cannot influence peripheries.</p>

Revision History

Month / Year	Version	Revised contents
01 / 2013	Si121096	First edition

Warning



- Daikin products are manufactured for export to numerous countries throughout the world. Prior to purchase, please confirm with your local authorised importer, distributor and/or retailer whether this product conforms to the applicable standards, and is suitable for use, in the region where the product will be used. This statement does not purport to exclude, restrict or modify the application of any local legislation.
- Ask a qualified installer or contractor to install this product. Do not try to install the product yourself. Improper installation can result in water or refrigerant leakage, electrical shock, fire or explosion.
- Use only those parts and accessories supplied or specified by Daikin. Ask a qualified installer or contractor to install those parts and accessories. Use of unauthorised parts and accessories or improper installation of parts and accessories can result in water or refrigerant leakage, electrical shock, fire or explosion.
- Read the User's Manual carefully before using this product. The User's Manual provides important safety instructions and warnings. Be sure to follow these instructions and warnings.

If you have any enquiries, please contact your local importer, distributor and/or retailer.

Cautions on product corrosion

1. Air conditioners should not be installed in areas where corrosive gases, such as acid gas or alkaline gas, are produced.
2. If the outdoor unit is to be installed close to the sea shore, direct exposure to the sea breeze should be avoided. If you need to install the outdoor unit close to the sea shore, contact your local distributor.

Dealer

DAIKIN INDUSTRIES, LTD.

Head Office:
Umeda Center Bldg., 2-4-12, Nakazaki-Nishi,
Kita-ku, Osaka, 530-8323 Japan

Tokyo Office:
JR Shinagawa East Bldg., 2-18-1, Konan,
Minato-ku, Tokyo, 108-0075 Japan

http://www.daikin.com/global_ac/

©All rights reserved