



REMOVAL PROCEDURE



SERVICE
MANUAL

S E R V I C E M A N U A L

10.0 kW Class

-  Outdoor Unit
-  Inverter
-  Multi Type



Service Manual Removal Procedure

Outdoor Unit

●Cooling Only
4MKD100DVM

Table of Contents

1. Removal of Outer Panels	2
2. Removal of the Electrical Box	19
3. Removal of PCB.....	25
4. Removal of Fan Motor.....	31
5. Removal of Coils / Thermistors	33
6. Removal of Reactor	38
7. Removal of Sound Blanket.....	39
8. Removal of Compressor	42

1. Removal of Outer Panels

Procedure



Warning Be sure to wait 10 minutes or more after turning off all power supplies before disassembling work.

Step	Procedure	Points
1. Remove the suction grille.		<ul style="list-style-type: none"> ■ The hooks are secured in the clearances of the heat exchanger fins.
1 Undo the 2 hooks at the bottom first.		

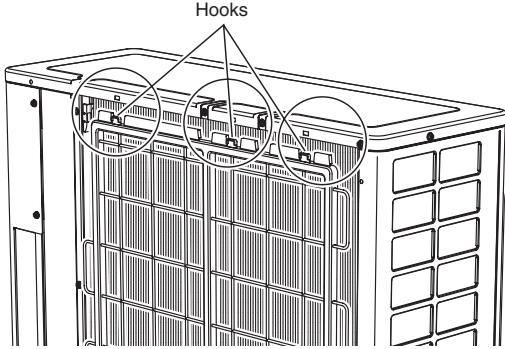
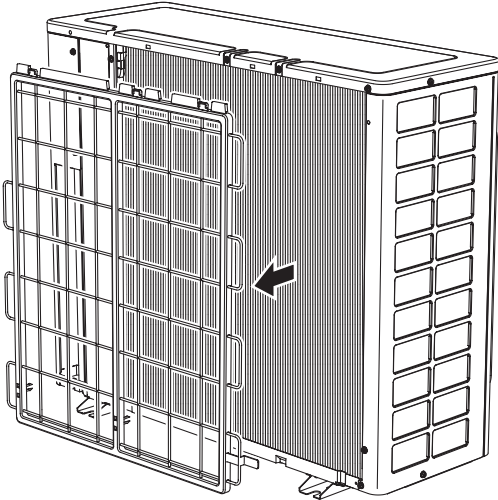
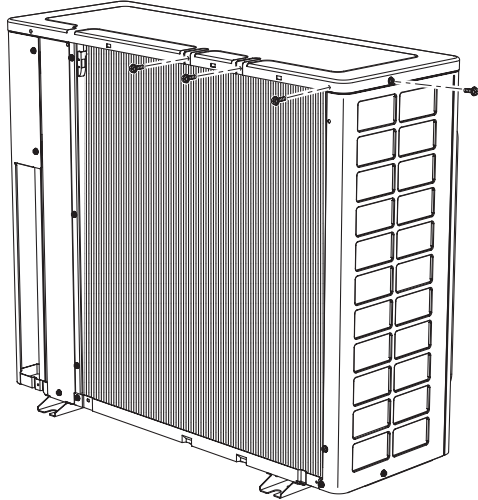
Step	Procedure	Points
2	<p>Next, slide the grille downward to undo the 3 top hooks.</p> 	
3	<p>Remove the suction grille.</p> 	
2.	<p>Remove the top panel.</p> <p>1 Remove 3 screws on the back and 1 screw on the left side panel.</p> 	

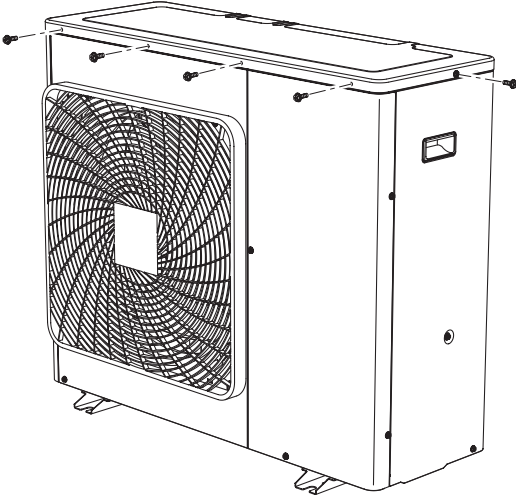
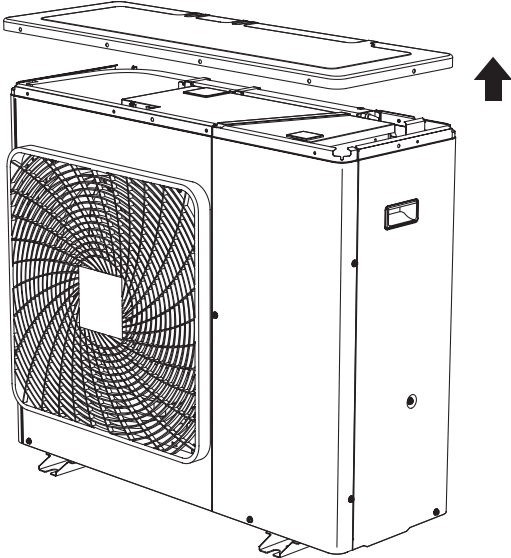
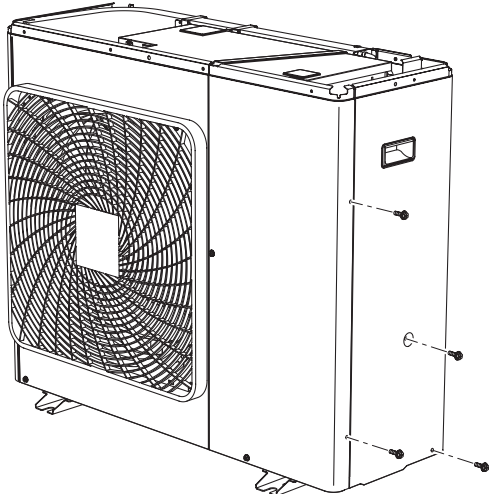
Step	Procedure	Points
2	<p>Remove 4 screws on the front and 1 screw on the right side panel.</p> 	
3	<p>Lift the top panel and remove it.</p> 	
3.	<p>Remove the right side panel.</p> <p>1 Remove 4 screws.</p> 	

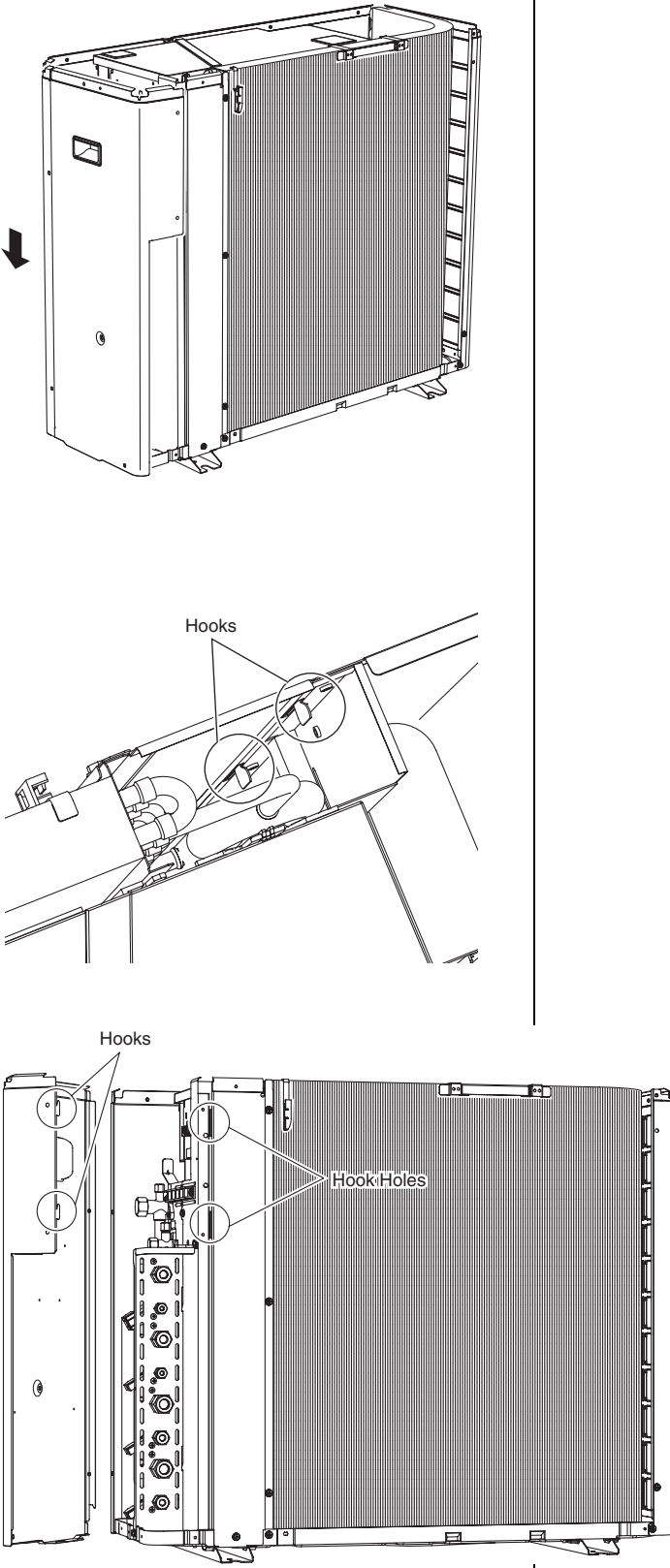
Step	Procedure	Points
2	<p data-bbox="199 219 470 309">Slide the panel downward to undo 2 hooks on the back side.</p> 	

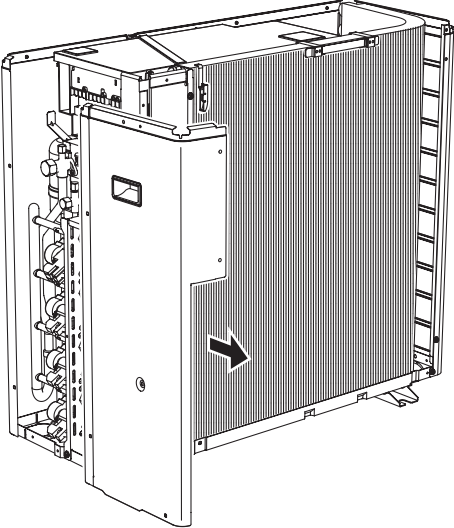
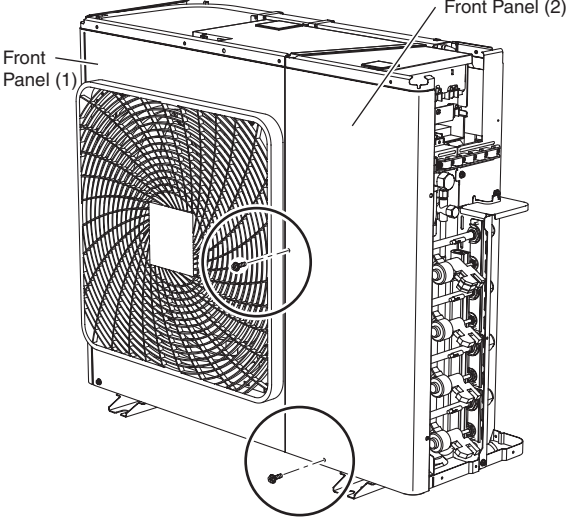
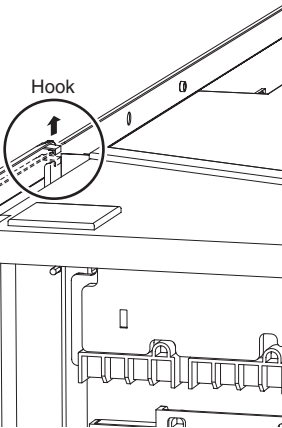
Step	Procedure	Points
3	<p>Remove the right side panel.</p> 	
4.	<p>Remove the front panel (2).</p> <p>1 Remove the 2 screws.</p>  <p>2 There is a hook at the top of the front panel (2). Slightly lift the front panel off position.</p> 	<ul style="list-style-type: none"> ■ The hook is provided to keep the front panel (2) secured in place. It covers the top projections of the front panel (1) from above.

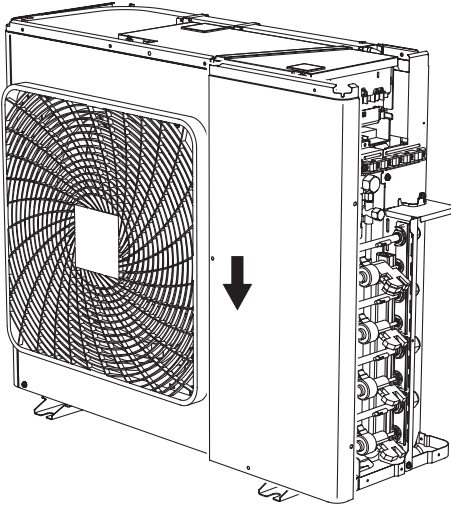
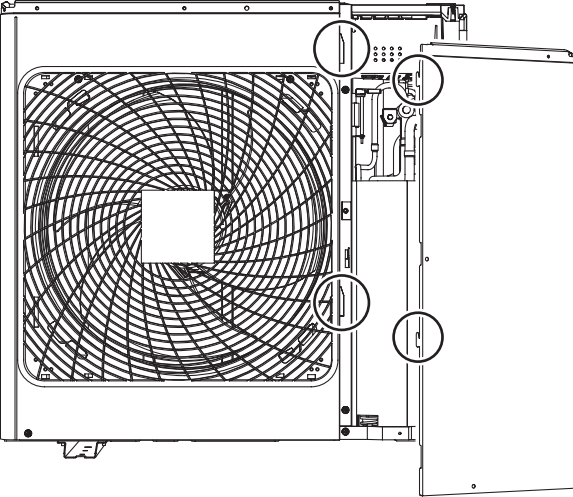
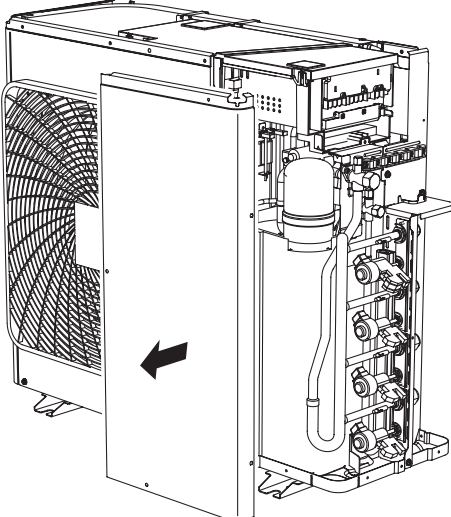
Step	Procedure	Points
3	Slide the panel downward to undo 2 hooks.	
		
		
4	Remove the front panel (2).	
		

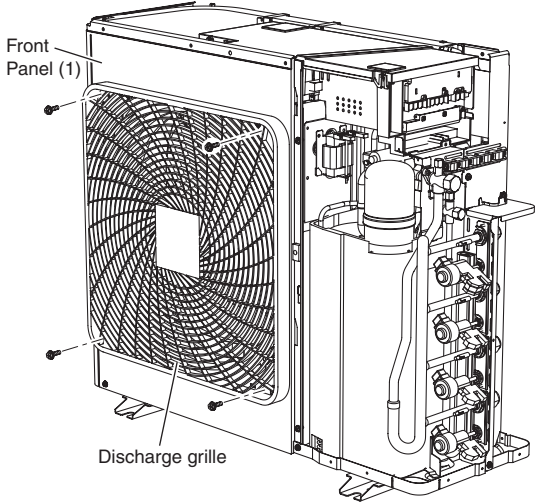
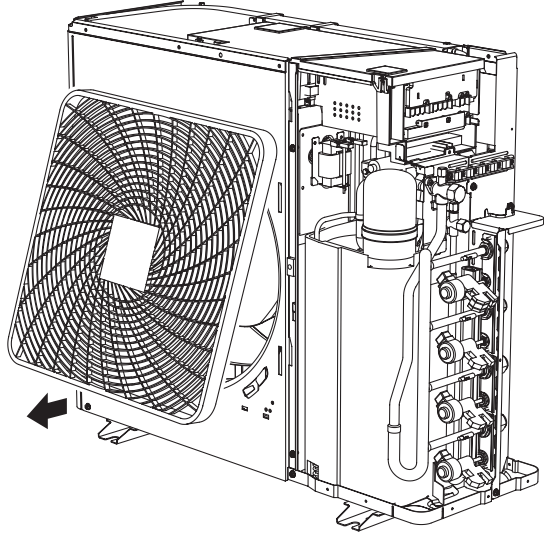
Step	Procedure	Points
5. Remove the front panel (1).		Remove the discharge grille and propeller fan first to remove the front panel (1).
1	<p>Remove the 4 screws on the discharge grille.</p> 	
2	<p>Pull the bottom of the discharge grille toward yourself.</p> 	

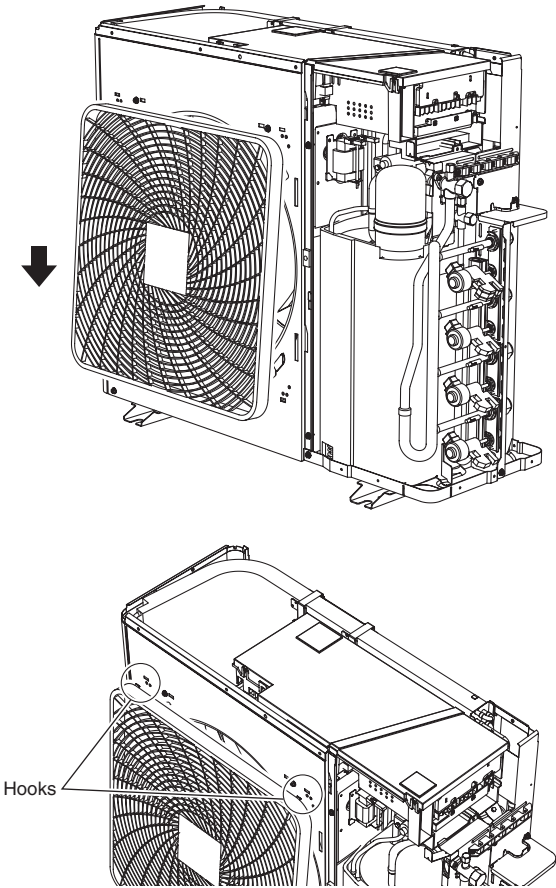
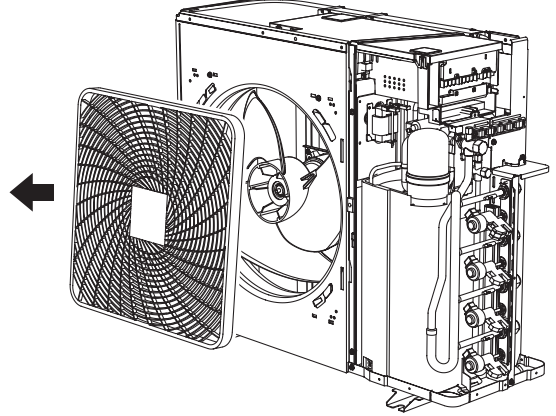
Step	Procedure	Points
3	<p data-bbox="199 219 469 309">Next, slide the grille downward to undo the 2 hooks at the top.</p> 	
4	<p data-bbox="199 1146 456 1214">Remove the discharge grille.</p> 	

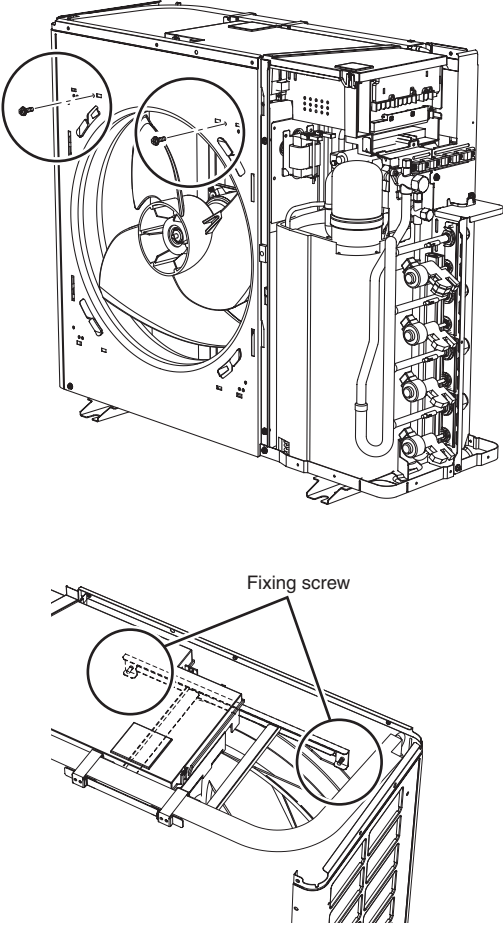
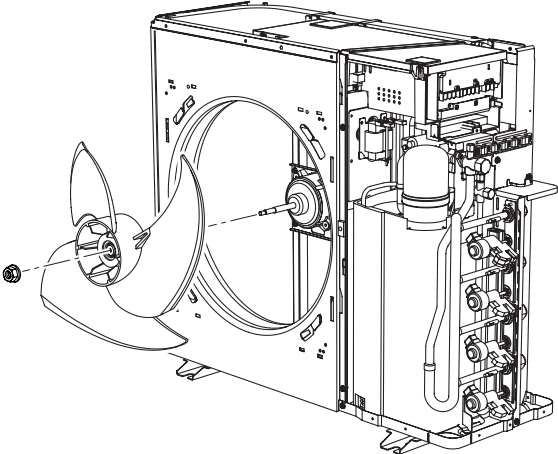
Step	Procedure	Points
5	<p>Remove the 2 fixing screws from the fan motor mount.</p> 	
6	<p>Remove the propeller fan fixing nut.</p> 	<p>Fan fixing nut : M8</p>

Step	Procedure	Points
7	Remove the 2 fixing screws on the partition plate.	
8	Remove the screw at bottom left of the front.	
9	Remove the screw at bottom of the left side.	

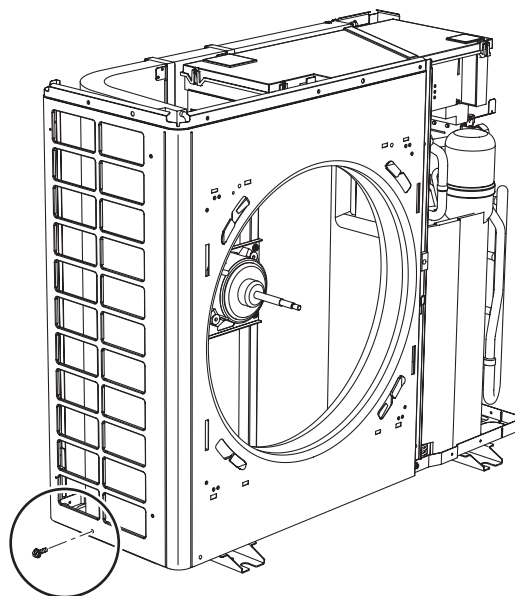
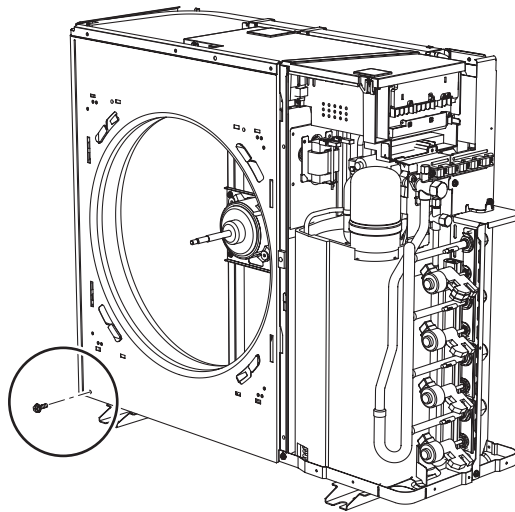
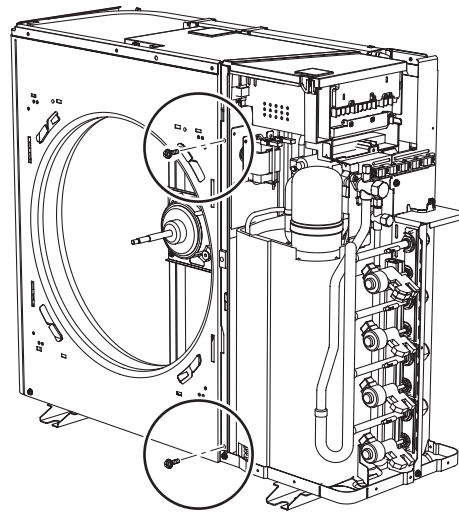

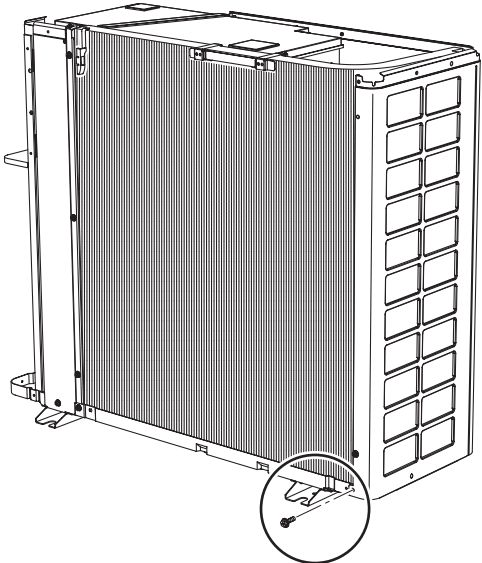
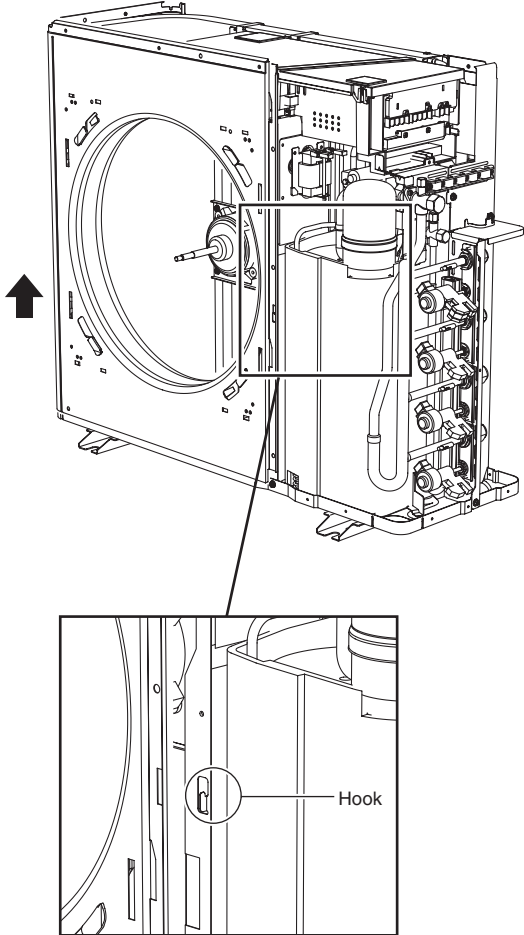
Step	Procedure	Points
10	<p>Remove the screw at bottom of the back side.</p> 	
11	<p>The front panel (1) is provided with a hook on its front. Lift the front panel off position to remove it.</p> 	

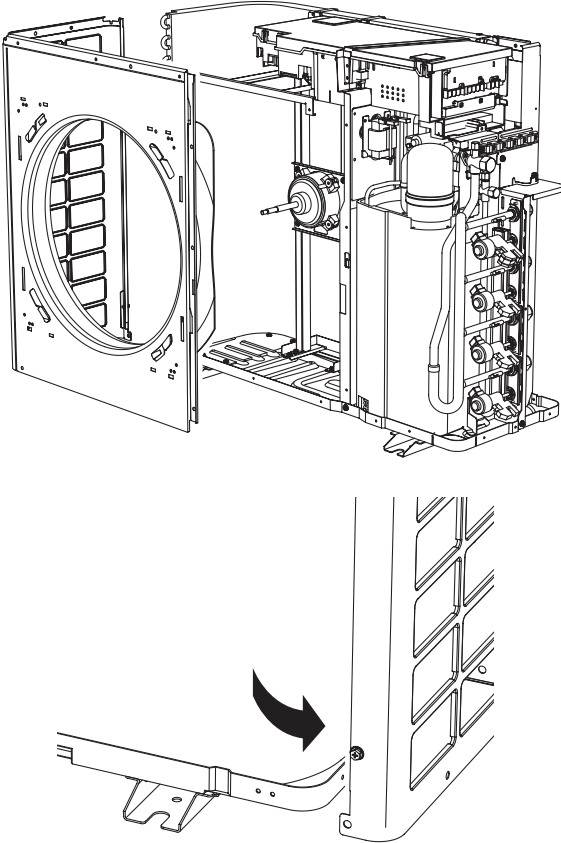
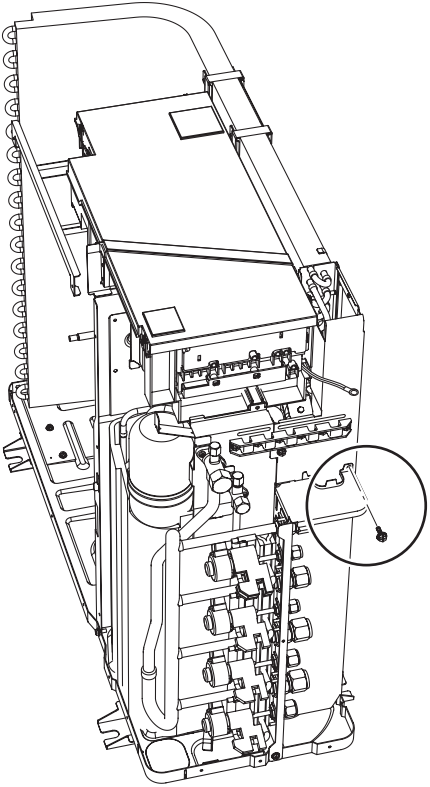
Step	Procedure	Points
12	<p data-bbox="199 219 464 280">Remove the front panel (1).</p> 	<ul style="list-style-type: none"> <li data-bbox="1093 712 1422 808">■ The back is a little complicated in shape. Be sure to detach carefully.
6.	<p data-bbox="199 1153 440 1182">Remove the rear panel.</p> <p data-bbox="199 1189 443 1283">1 Remove the fixing screw on the partition plate.</p> 	

Step	Procedure	Points
2	Slide the panel leftward to undo the hook.	
3	Remove the partition plate.	
4	Remove the 6 screws.	

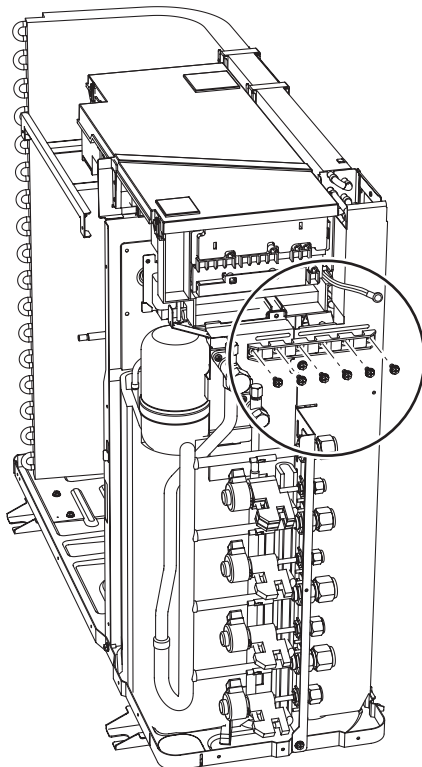
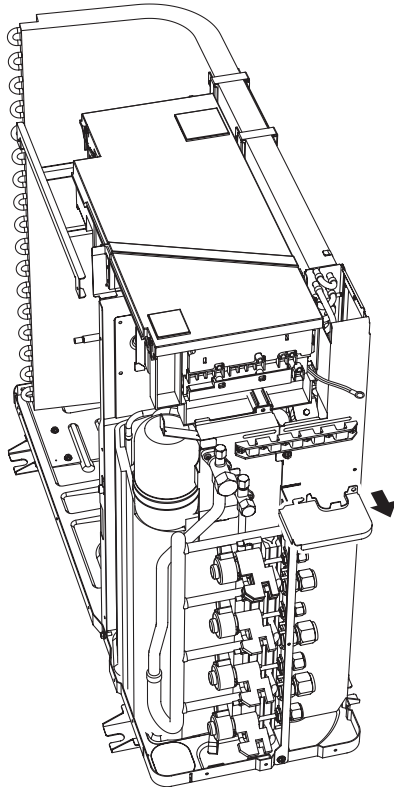
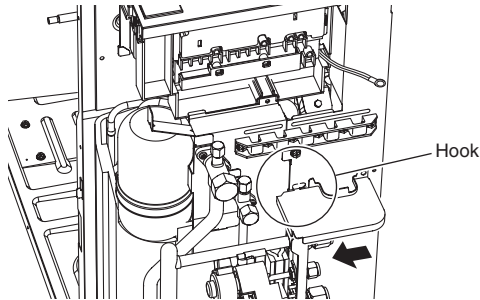

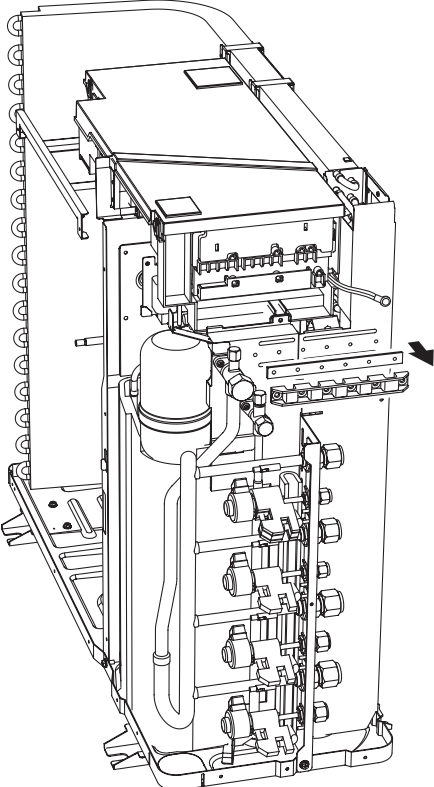
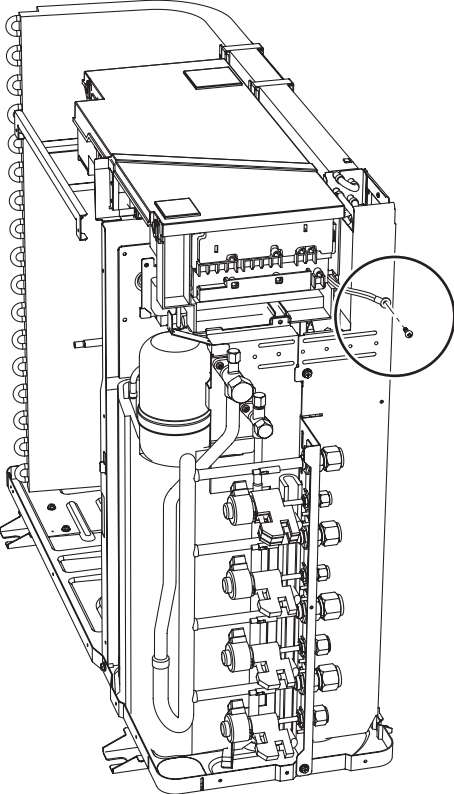
Step	Procedure	Points
5	Remove the wire fixing plate. 	
6	Remove the screw of the earth wire. 	

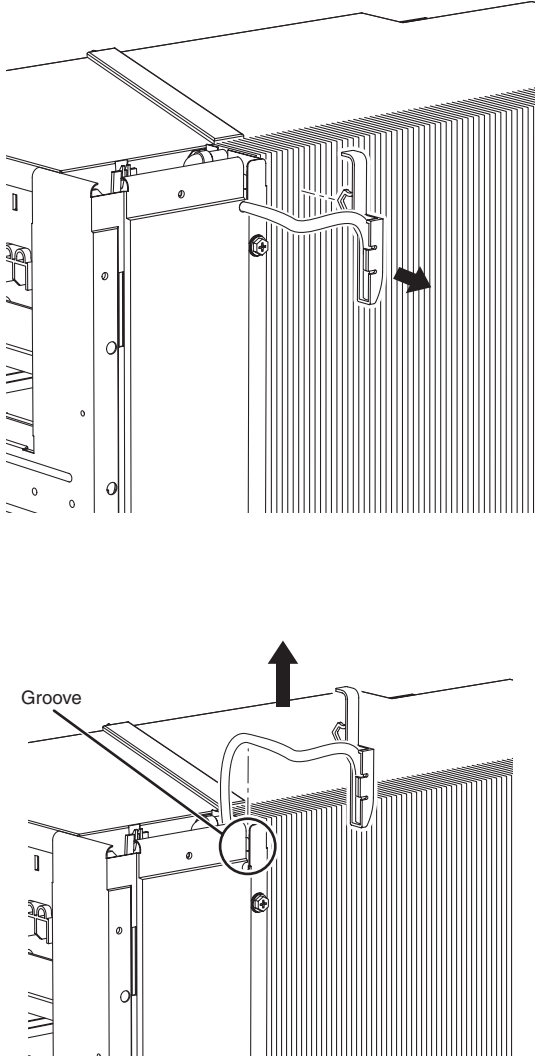
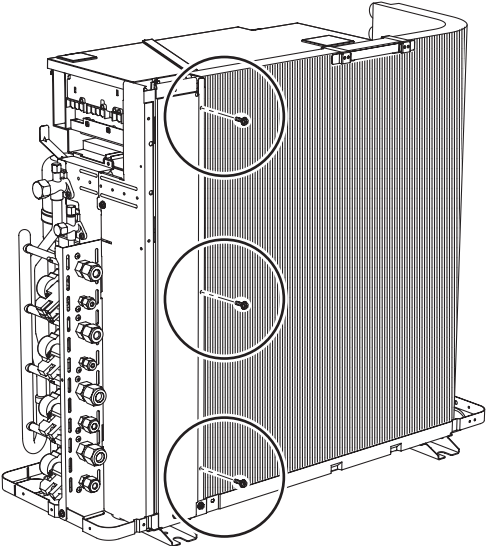
Step	Procedure	Points
<p>7</p> <p>Undo the holder of the thermistor.</p>		<ul style="list-style-type: none"> ■ The holder is secured in the clearances of the heat exchanger fins.
<p>8</p> <p>Remove the 3 fixing screws on the partition plate.</p>		

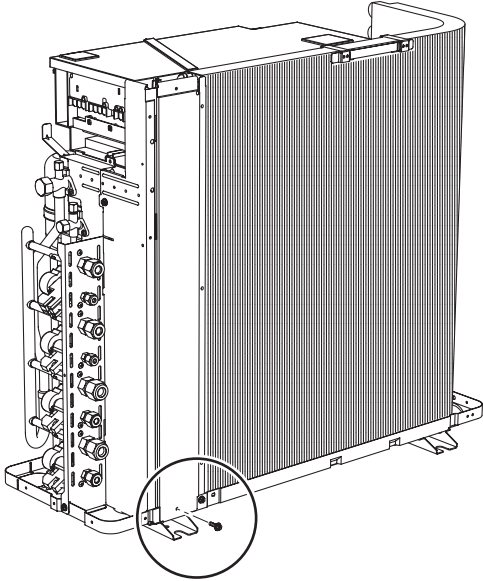
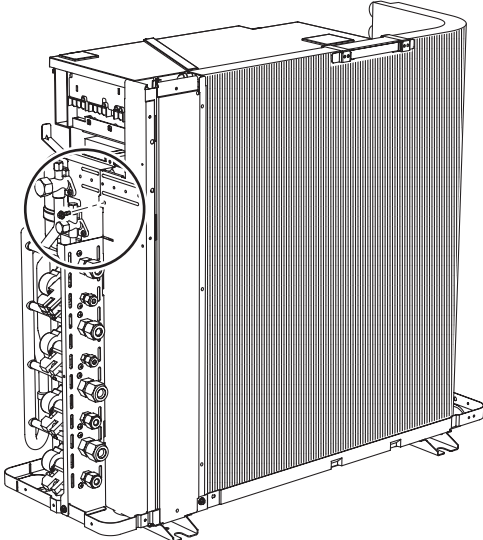
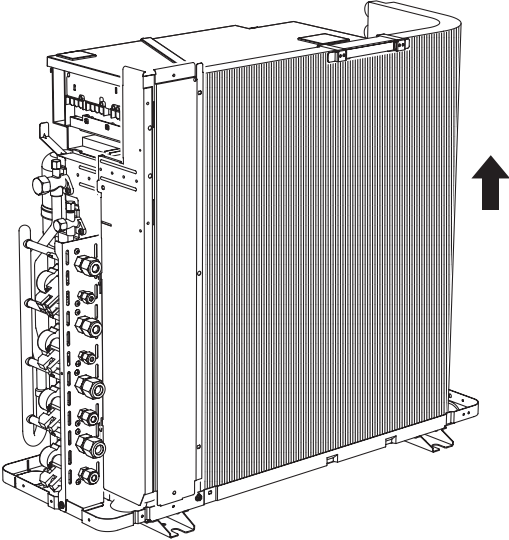
Step	Procedure	Procedure	Points
9	Remove the fixing screw from the bottom frame.		
10	Remove the fixing screw from the shut-off valve mounting plate.		
11	Lift the panel upward to undo the 2 hooks and remove it.		

Step	Procedure	Points
12	<p>The bottom is sandwiched in the bottom frame. Lift up to detach.</p>	
13	<p>Remove the rear panel.</p>	

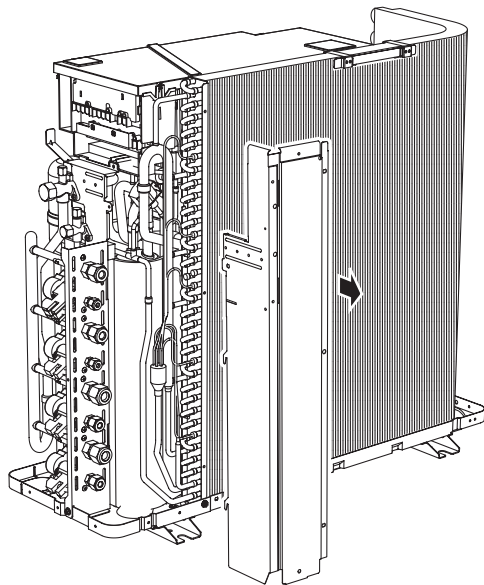
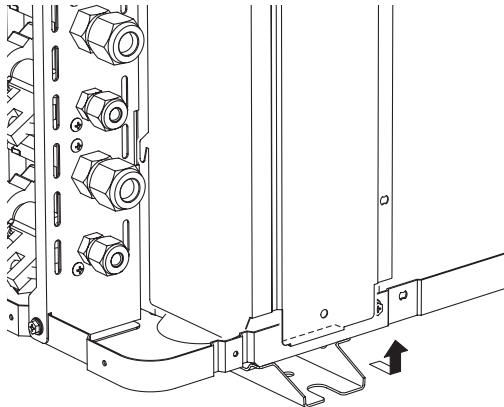
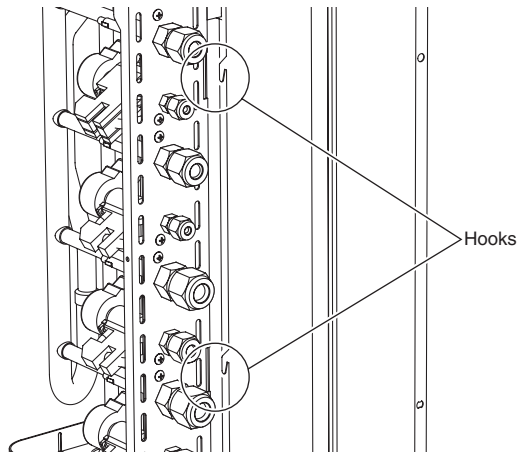

2. Removal of the Electrical Box

Procedure

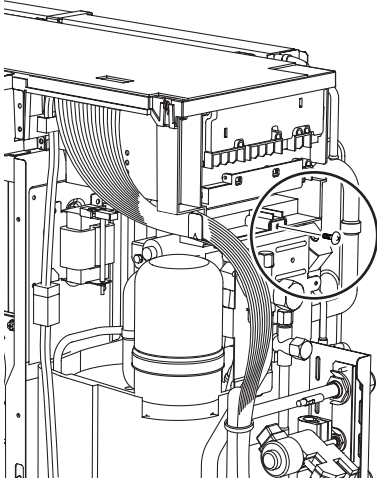
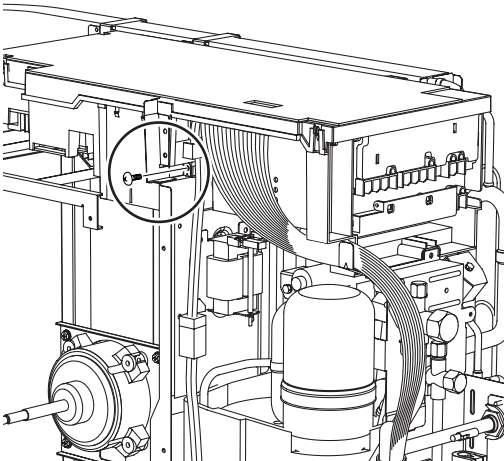
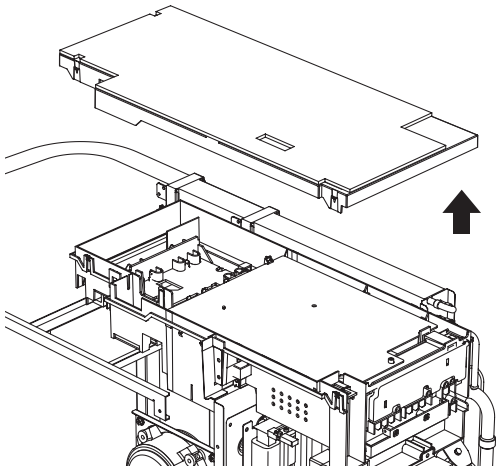
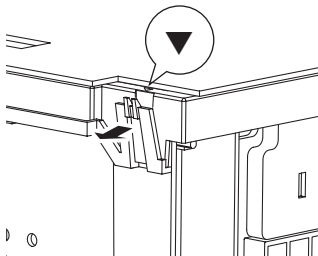

Warning Be sure to wait 10 minutes or more after turning off all power supplies before disassembling work.

Step	Procedure	Points
1	Remove the fixing screw from the shut-off valve mounting plate. 	
2	Remove the fixing screw on the partition plate. 	
3	Open the cover of the electrical box. 	<ul style="list-style-type: none"> ■ Undo the 4 hooks. The hooks are marked with ▼. 

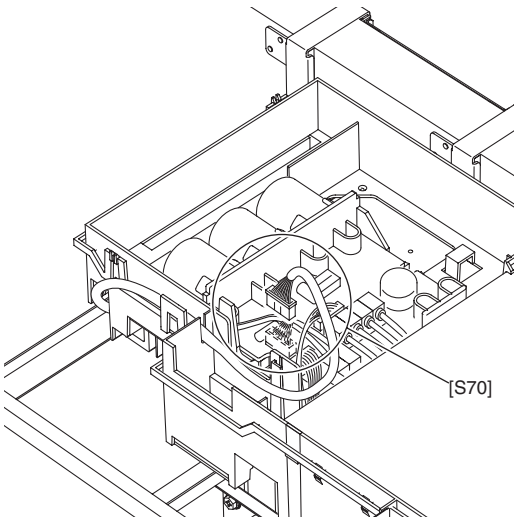
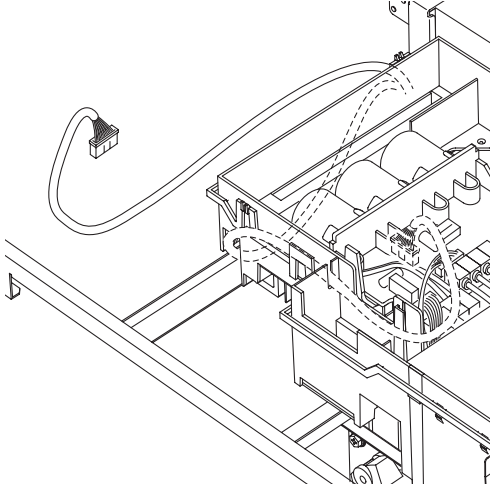
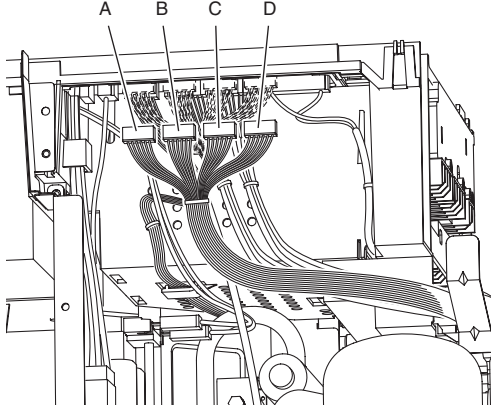
Step	Procedure	Procedure	Points
4	Disconnect the fan motor connector [S70].		
5	Disconnect the fan motor wire harness.		
6	Disconnect the 4 motorized valve connectors (for Rooms A, B, C and D).		<p>■ A : Connector [S20] (white), B : Connector [S21] (red), C : Connector [S22] (blue), D : Connector [S23] (yellow).</p>

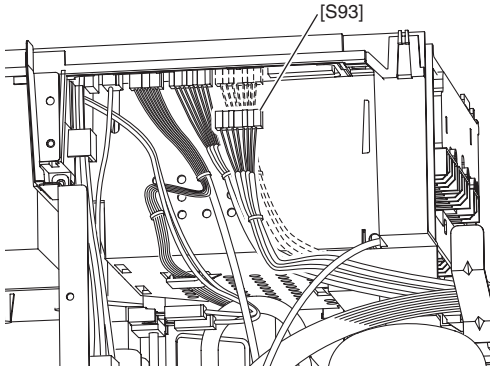
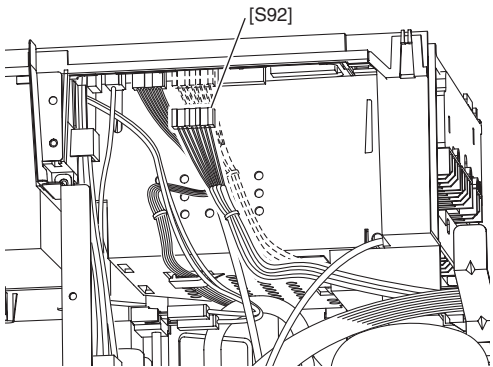
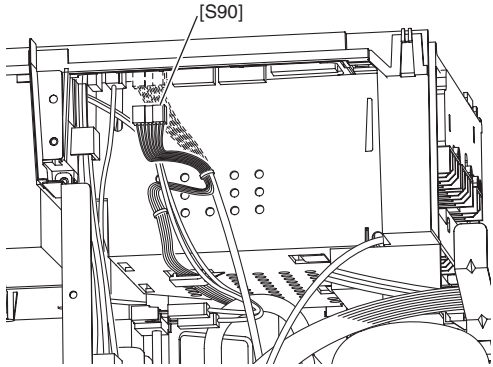
Step	Procedure	Procedure	Points
7	Disconnect the liquid pipe thermistor connector [S93].		
8	Disconnect the gas pipe thermistor connector [S92].		
9	Disconnect the discharge pipe thermistor connector [S90].		

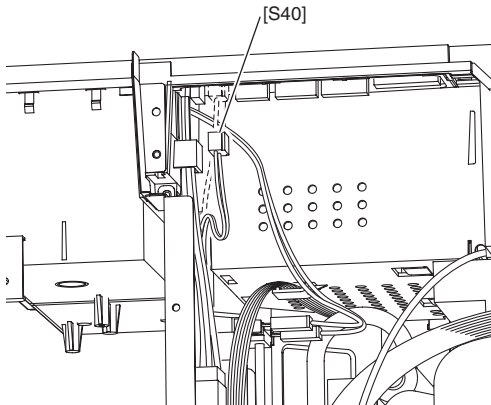
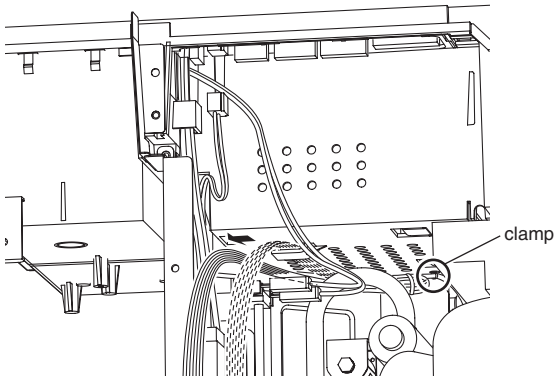
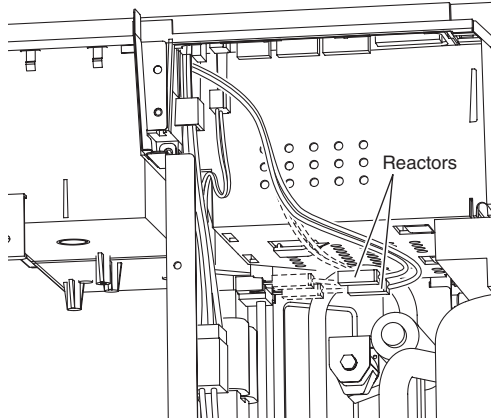
Step	Procedure	Points
10	Disconnect the OL connector [S40].	
	 <p>A technical line drawing of an electrical control panel. A wire harness is shown entering from the top left. A specific connector is labeled [S40]. The harness is connected to a terminal block with several rows of terminals. The drawing shows the harness being disconnected from the [S40] connector.</p>	
11	The wire harness is hooked on the bottom of the electrical box. Unhook it and remove the clamp.	
	 <p>A technical line drawing of the same electrical control panel. The wire harness is now hooked onto a metal bracket at the bottom of the panel. A circular clamp is used to secure the harness to the bracket. The label 'clamp' points to this circular component.</p>	
12	Disconnect the 2 reactor wire harnesses.	
	 <p>A technical line drawing of the electrical control panel. Two specific wire harnesses are highlighted with dashed lines, indicating they are to be disconnected. The terminal block is labeled 'Reactors'. The drawing shows these two harnesses being disconnected from their respective terminals.</p>	

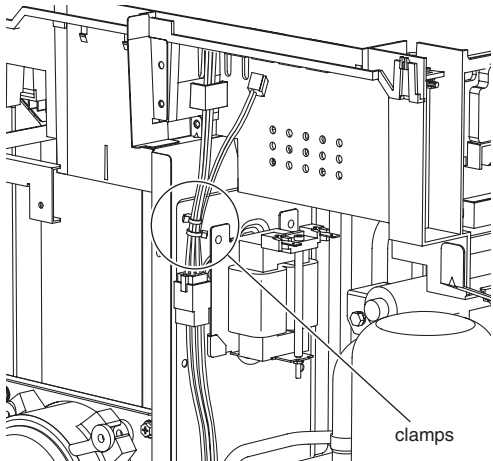
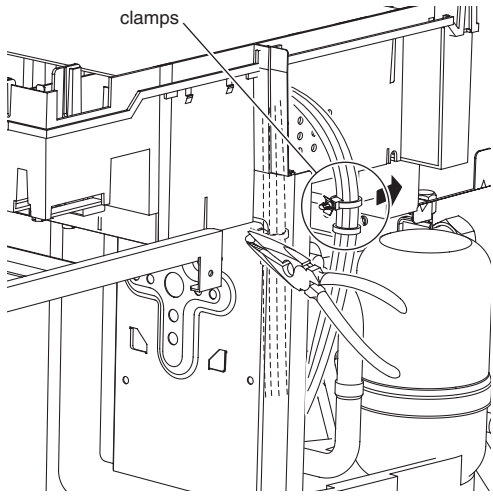
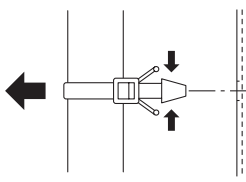
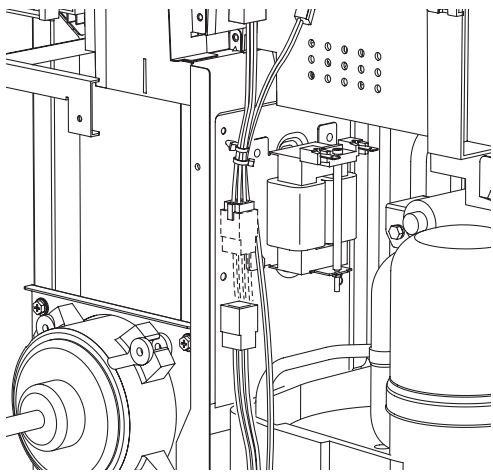
Step	Procedure	Procedure	Points
13	Remove the OL wire harness and the compressor wire harness together from the partition.	 <p style="text-align: right;">clamps</p>	
14	Use long-nose pliers or the like to pull out the clamps.	 <p style="text-align: right;">clamps</p>	<p>■ Detach the clamp.</p> 
15	Disconnect the relay connector of the compressor.		

Step	Procedure	Points
16	Cut off the clamps of the OL wire harness and compressor wire harness.	<ul style="list-style-type: none"> ■ Cut off with nippers.
17	First, slide the box leftward do undo the hook on the right side of the box.	
18	Lift up the electrical box to remove it.	

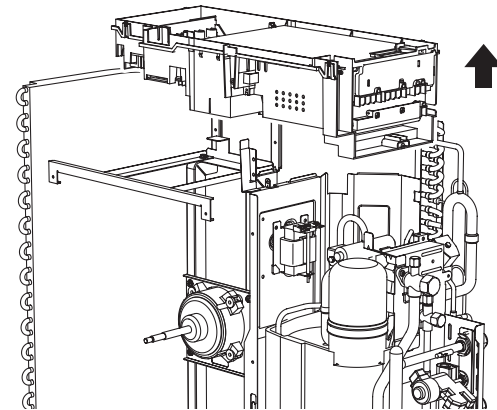
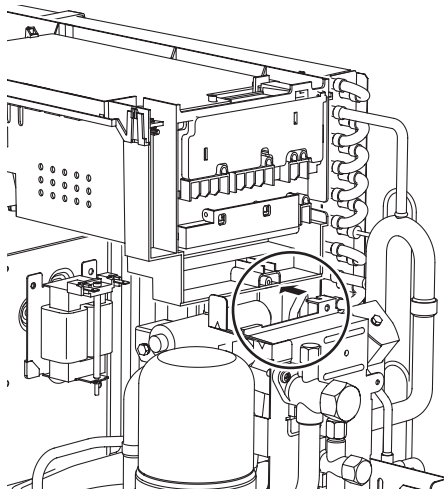
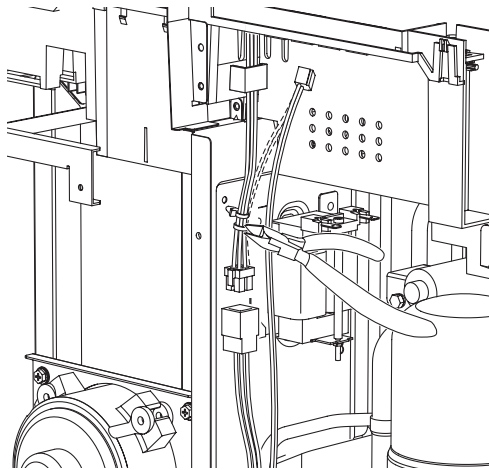

3. Removal of PCB

Procedure

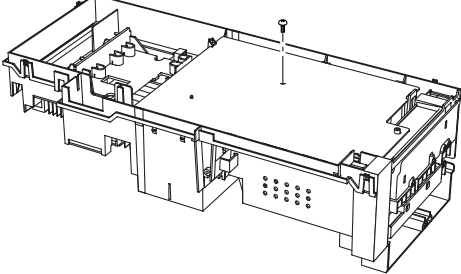
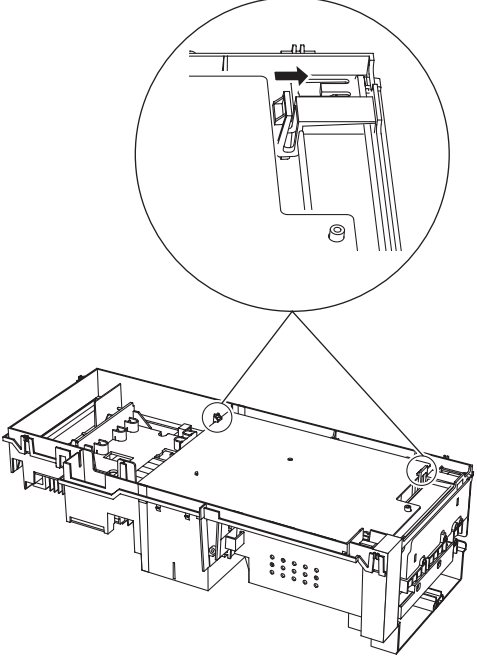
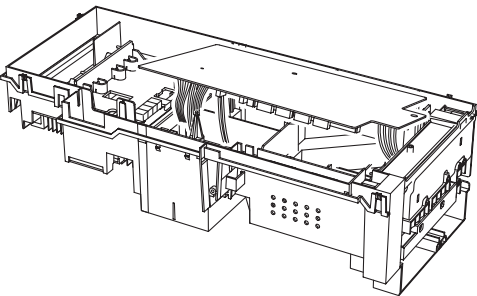

Warning Be sure to wait 10 minutes or more after turning off all power supplies before disassembling work.

Step	Procedure	Points
1.	Remove the Control PCB.	
1	Remove the screw.	
2	Undo the 2 hooks.	
3	Lift up your side of the control PCB.	

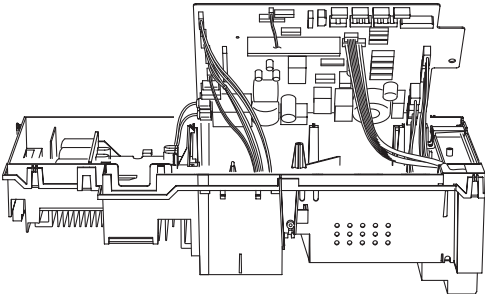
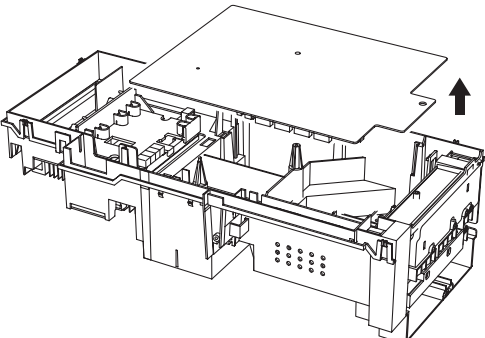
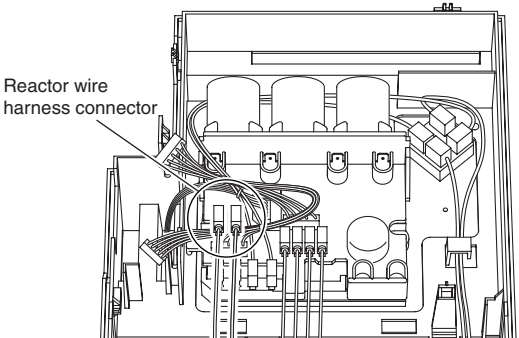
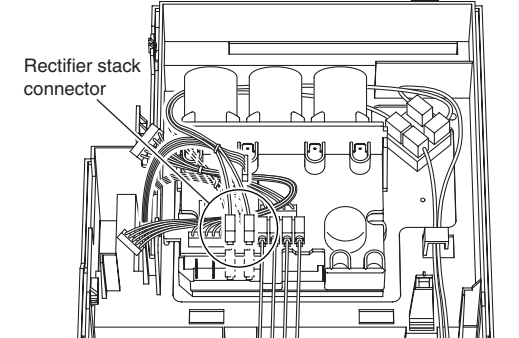
Step	Procedure	Points	
4	Disconnect the connectors one by one starting from your side.	<ul style="list-style-type: none"> ● Connectors [S33] & [S71]: For inverter PCB ● Connectors [S31] & [S32]: For SPM PCB ● Connectors [S51] & [S101]: For display PCB ● Connector [S10]: For relay PCB ● Connectors [H1/H2]: For DB (diode bridge), power wire harnesses AC1 (red) and AC2 (black) 	
5	Remove the control PCB.		
			
2. Remove the inverter PCB.			
1	Disconnect the reactor wire harness connector.	■ Connector [L1/L2]	
	2	Disconnect the rectifier stack connector.	■ Black and red
			

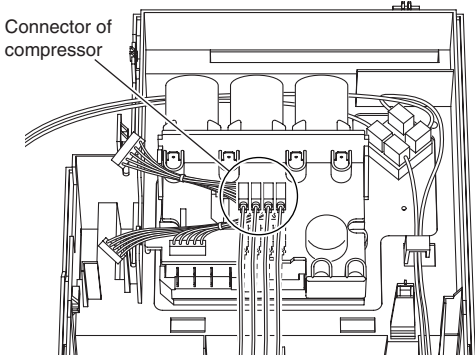
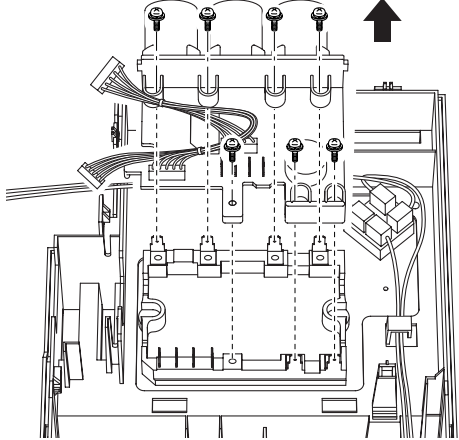
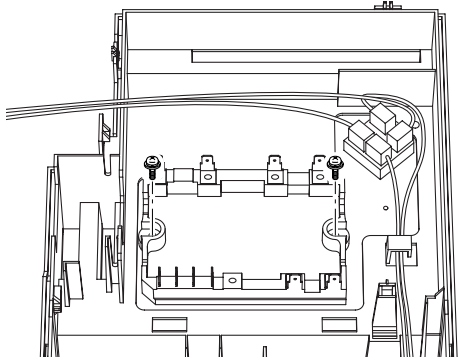
Step	Procedure	Points
3	Disconnect the connector of the compressor. 	■ Blue, yellow, red, and brown
4	Remove the 7 screws.	
5	Lift the inverter PCB upward to remove it.	
		
3.	Remove the SPM.	
1	Remove the 2 screws.	

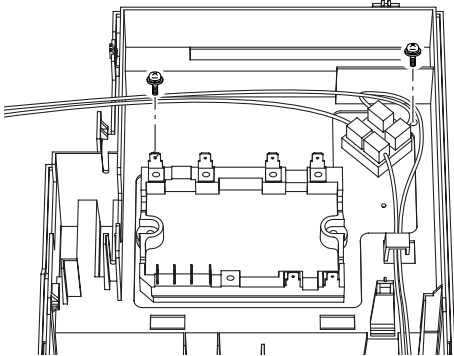
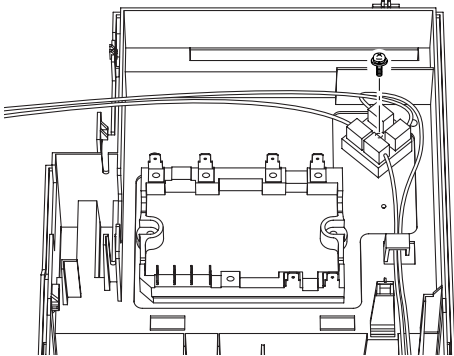
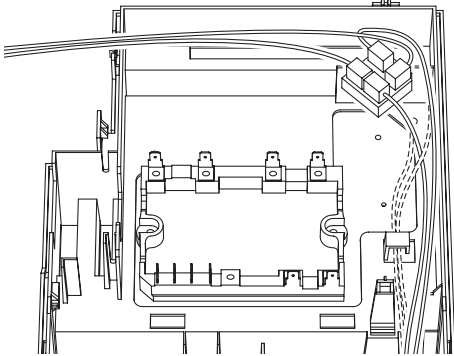
Step	Procedure	Points
2	Remove the 2 screws.	
	 <p>A technical line drawing of the PCB assembly from a top-down perspective. Two screws are indicated with dashed lines and arrows, showing they are to be removed from the top panel of the assembly.</p>	
3	Remove the screw (rectifier stack).	
	 <p>A technical line drawing of the PCB assembly, similar to the previous one. A single screw is indicated with a dashed line and an arrow, showing it is to be removed from the rectifier stack area.</p>	
4	Remove the rectifier stack.	
	 <p>A technical line drawing of the PCB assembly. The rectifier stack is shown being lifted away from the main assembly, with dashed lines indicating its removal path.</p>	

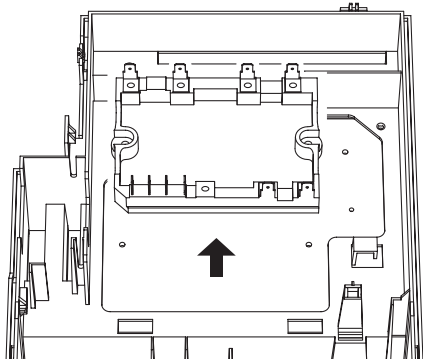
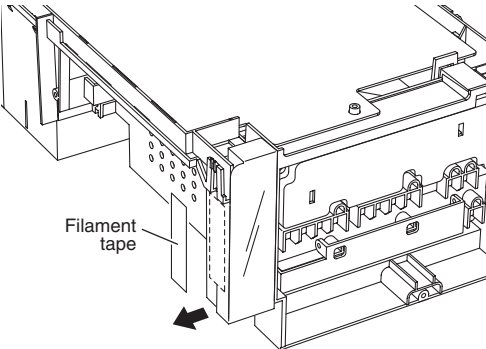
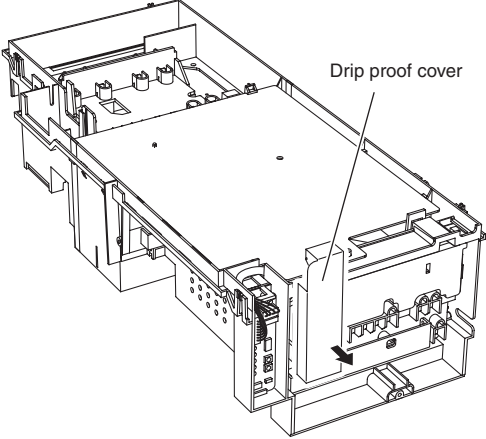
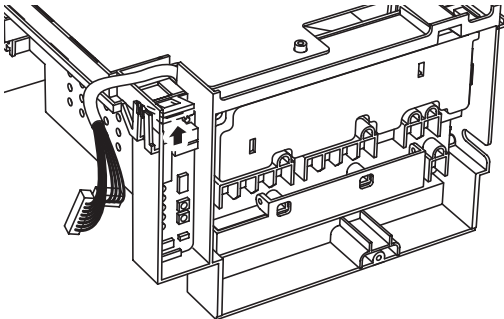
Step	Procedure	Points
5	Remove the SPM. 	
4.	Remove the display PCB. <ol style="list-style-type: none"> <li data-bbox="153 678 193 741">1 Remove the filament tape.  <li data-bbox="153 1055 193 1117">2 Remove the drip proof cover.  <li data-bbox="153 1559 193 1621">3 Slightly lift the top hooks to detach.  	

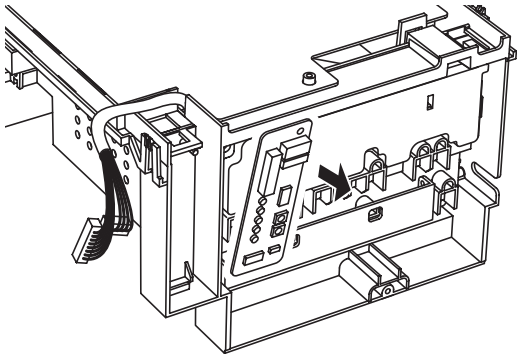
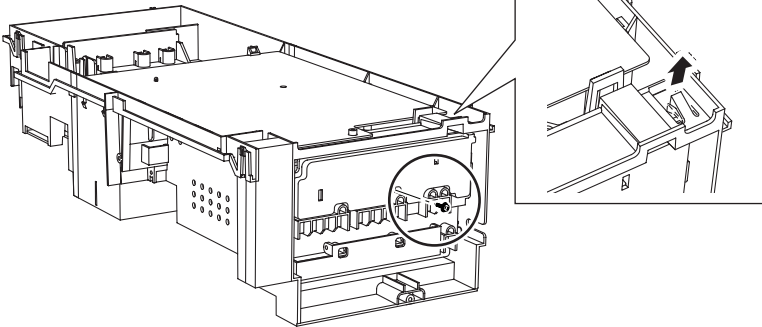
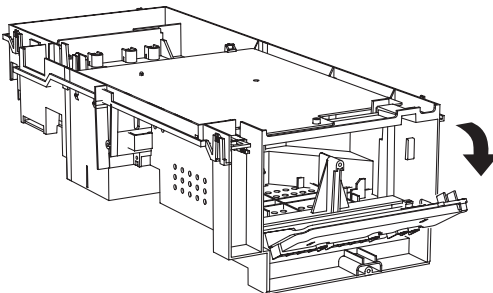
Step	Procedure	Points
4	Undo the bottom hook to remove the display PCB.	
5.	Remove the servicing cover off the terminal block assembly.	
1	Remove the screw.	
2	Lift the hook to detach.	
3	Open the cover toward yourself.	

4. Removal of Fan Motor

Procedure



Warning

Be sure to wait 10 minutes or more after turning off all power supplies before disassembling work.

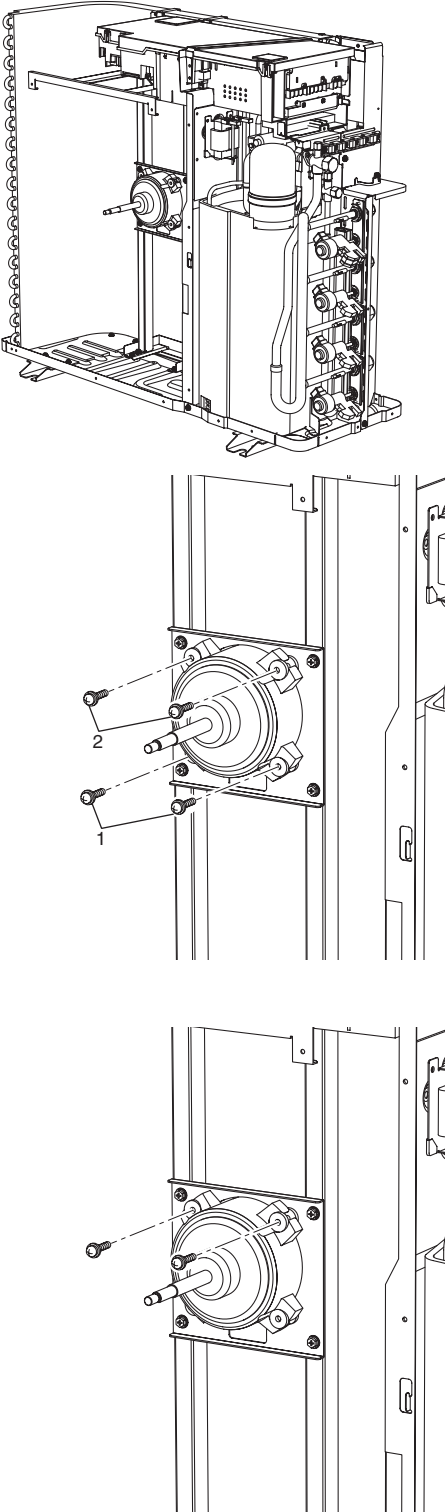
Step	Procedure	Points
1 Remove the 2 screws at the bottom first. 2 Next, remove the 2 top screws.		<p>Be sure to remove the bottom screws first. If the top screws are removed first, the fan motor, the center of gravity of which is toward the front, may tilt down or fall, getting you injured.</p>

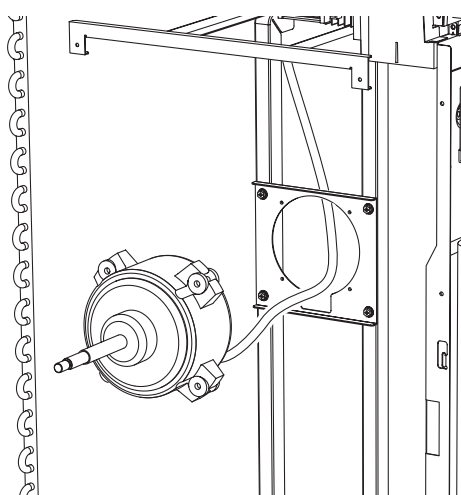
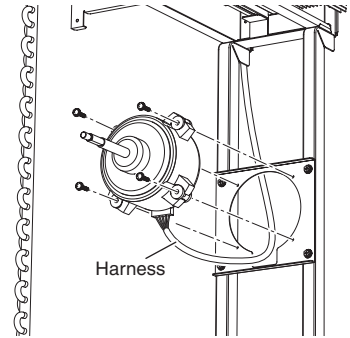
Step		Procedure	Points
3	Remove the fan motor.		<p>When reassembling, be sure to place the wire harness lower.</p> 

5. Removal of Coils / Thermistors

Procedure

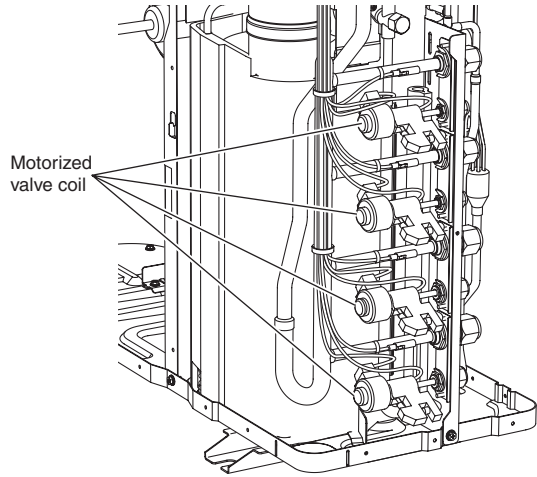
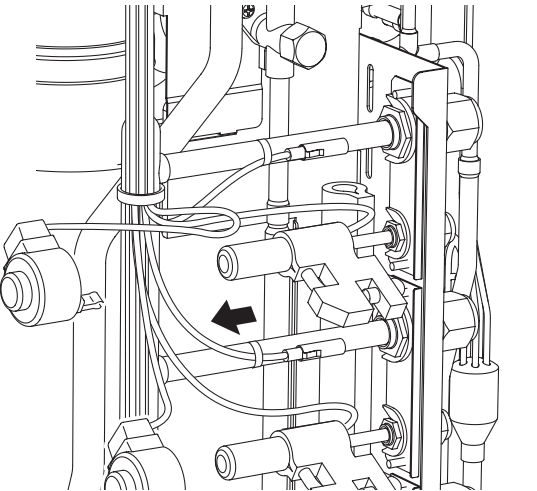

Warning Be sure to wait 10 minutes or more after turning off all power supplies before disassembling work.

Step	Procedure	Points
1. Remove the motorized valve coil.	 	

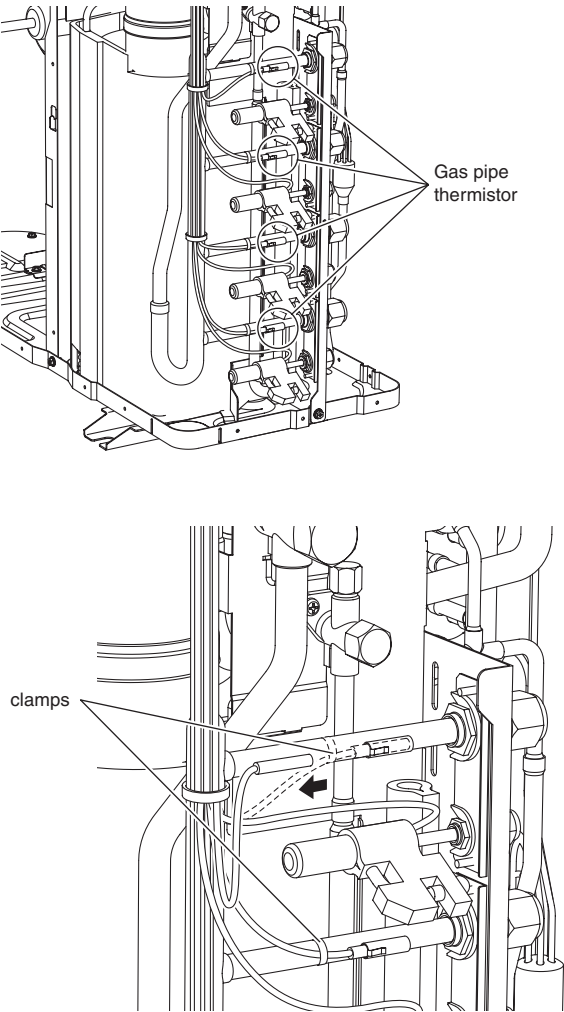
Step	Procedure	Points
<p>2</p>	<p>Remove the clamp from the gas pipe thermistor, and pull out the thermistor.</p> 	

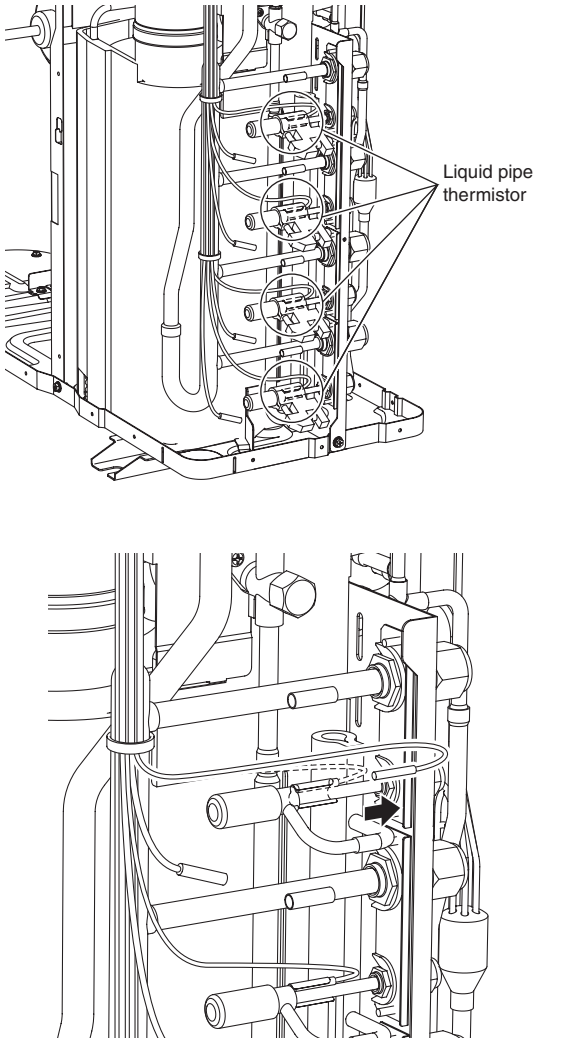
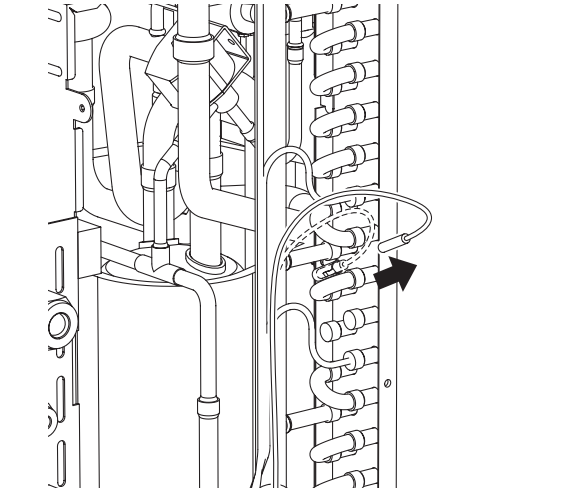
Step	Procedure	Points
3	Peel the putty from the liquid pipe thermistor, and pull out the thermistor.	
		
2. Removal of Thermistors		
1	Pull out the heat exchanger thermistor.	
		

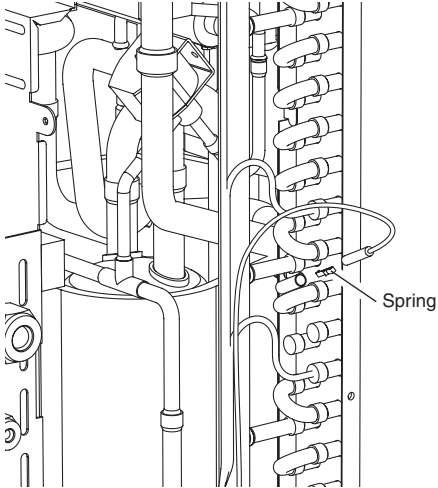
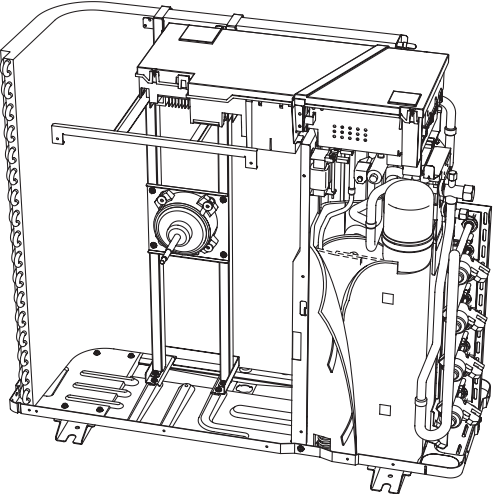
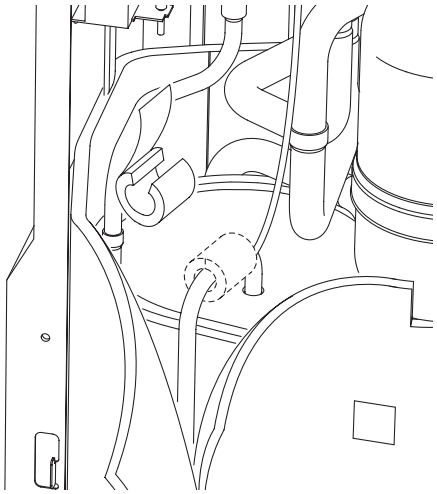
Step	Procedure	Points
2	<p>Remove the spring from the heat exchanger thermistor.</p> 	<ul style="list-style-type: none"> ■ Be careful not to lose the spring.
3	<p>Slightly open the sound blanket.</p> 	
4	<p>Remove the insulation sleeve.</p> 	

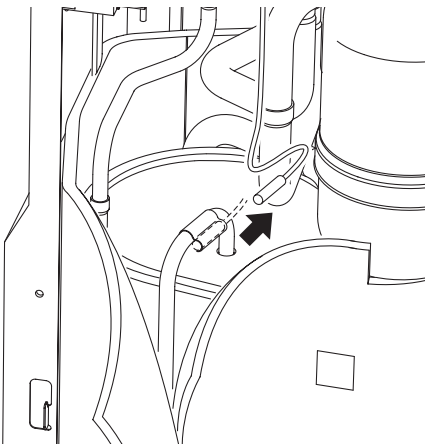
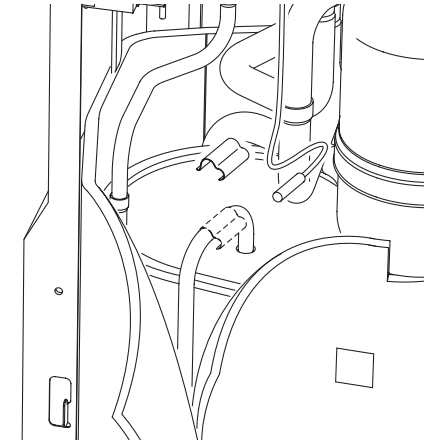
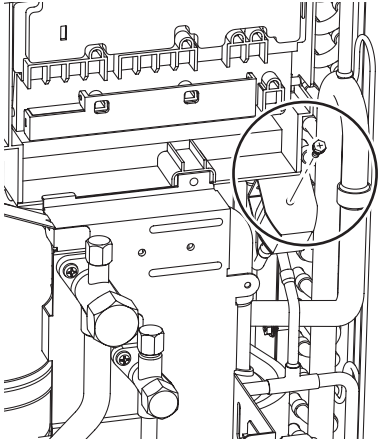
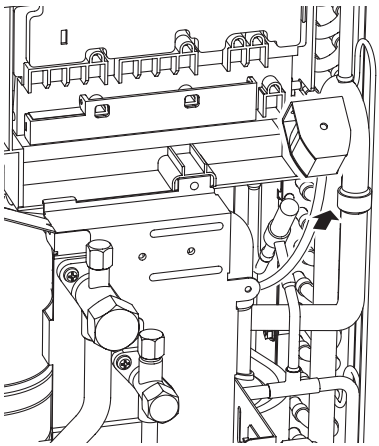
Step	Procedure	Points
5	<p data-bbox="197 215 459 277">Remove the discharge pipe thermistor.</p> 	
6	<p data-bbox="197 1146 421 1182">Remove the fixture.</p> 	
3.	<p data-bbox="197 1146 432 1209">Remove the motorized valve coil</p>	
1	<p data-bbox="197 1218 421 1254">Remove the screw.</p> 	
2	<p data-bbox="197 1666 459 1729">Remove the motorized valve coil.</p> 	

6. Removal of Reactor

Procedure



Warning Be sure to wait 10 minutes or more after turning off all power supplies before disassembling work.

Step	Procedure	Points
1	Remove the screw.	
2	Lift the reactor upward to undo the hooks.	
3	Remove the reactor.	

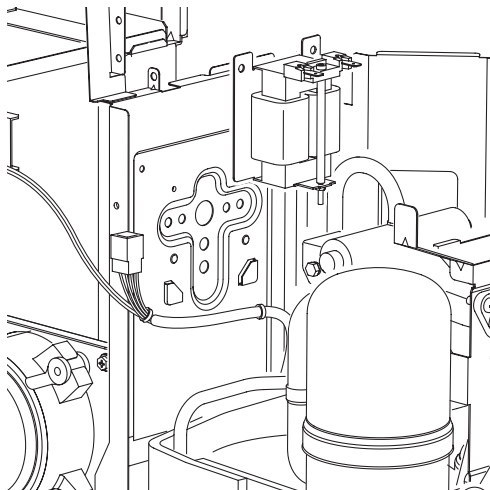
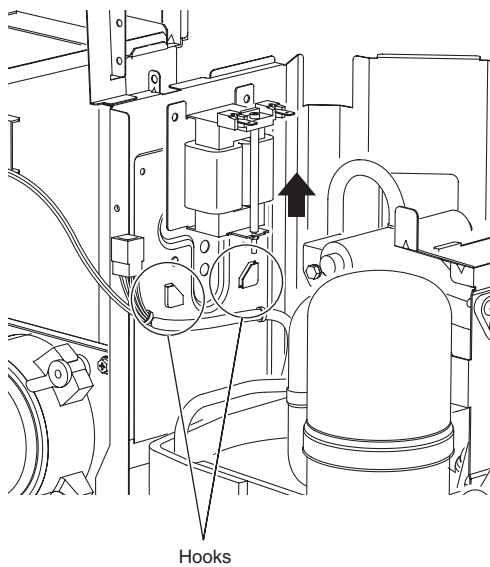
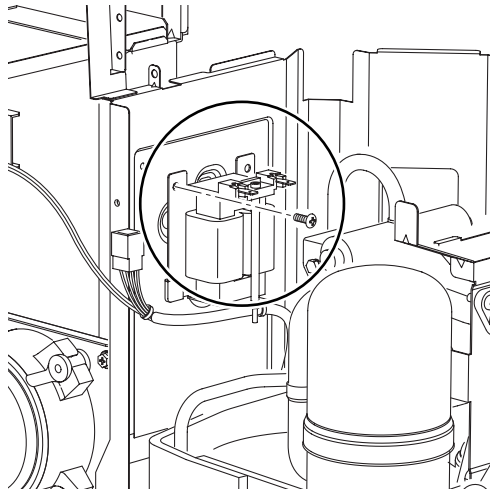

7. Removal of Sound Blanket

Procedure



Warning Be sure to wait 10 minutes or more after turning off all power supplies before disassembling work.

Step	Procedure	Points
1	Disconnect the compressor wire harness from the partition plate.	■ Fixed at 2 locations
2	Undo the 2 Velcro tapes off the sound blanket, and open the sound blanket (outer sleeve).	

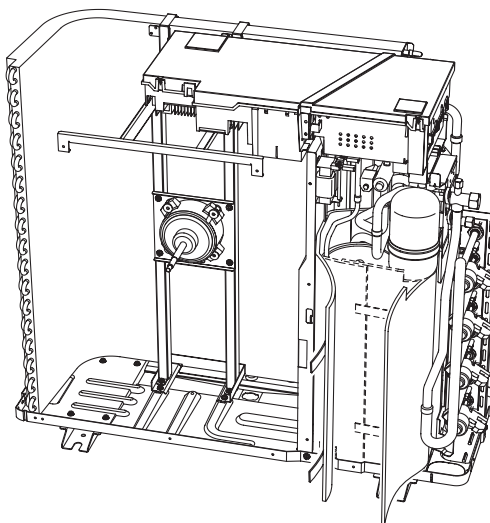
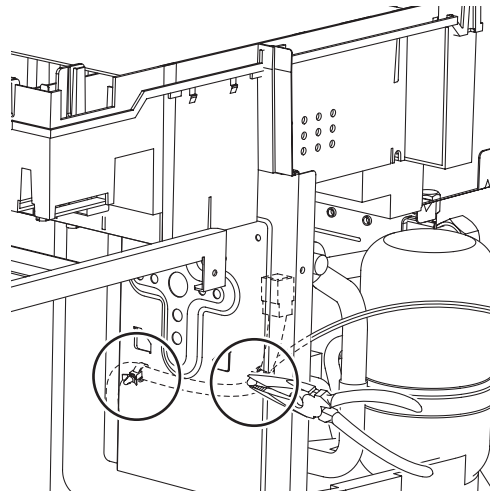
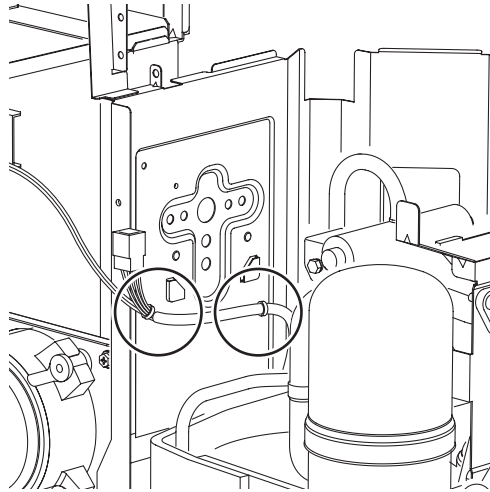

Step	Procedure	Points
3	Remove the sound blanket (top upper).	<ul style="list-style-type: none"> ■ The sound blanket is fragile. Carefully pass the discharge pipe through it.
4	Remove the sound blanket (outer sleeve).	<ul style="list-style-type: none"> ■ The sound blanket is fragile. Be careful of the notches of the compressor mount (3 locations).
5	Remove the screw from the partition plate and open the plate slightly to the left for easy work.	

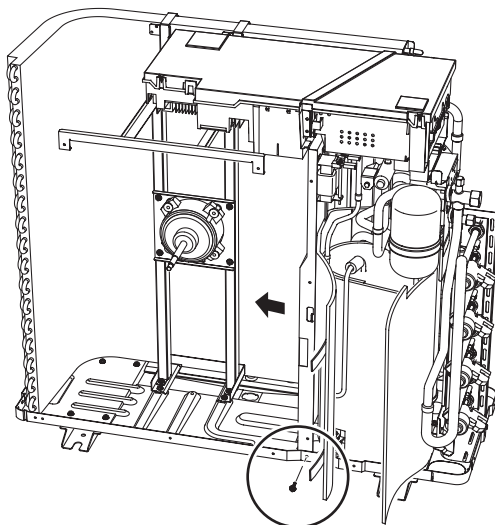
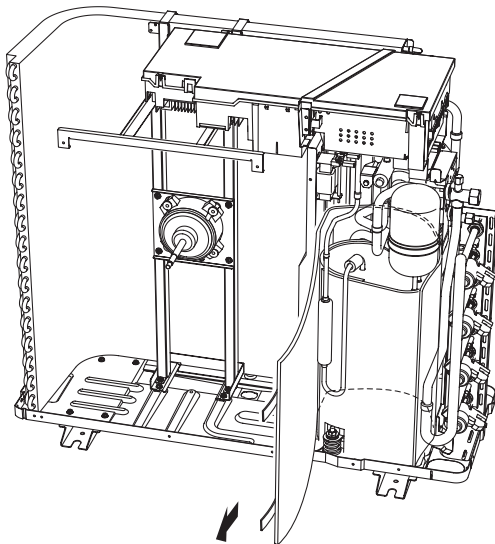
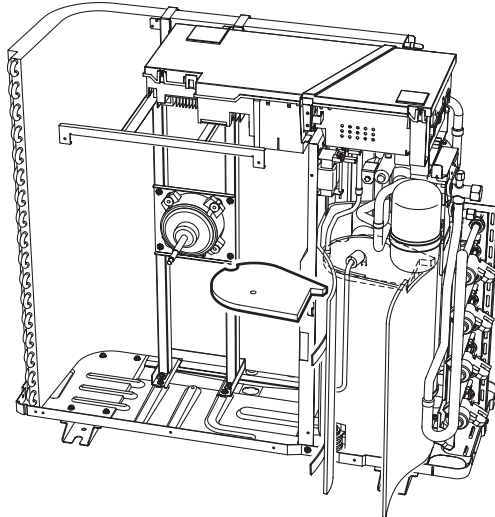

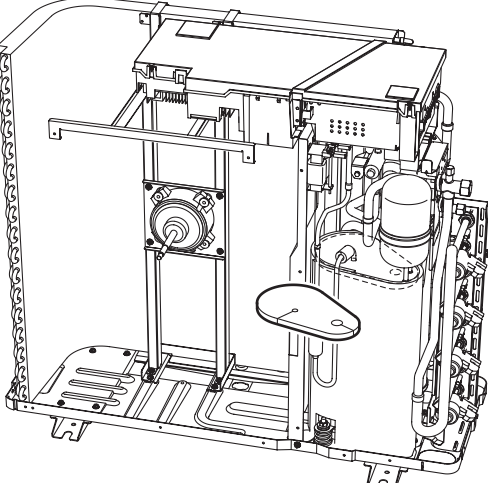
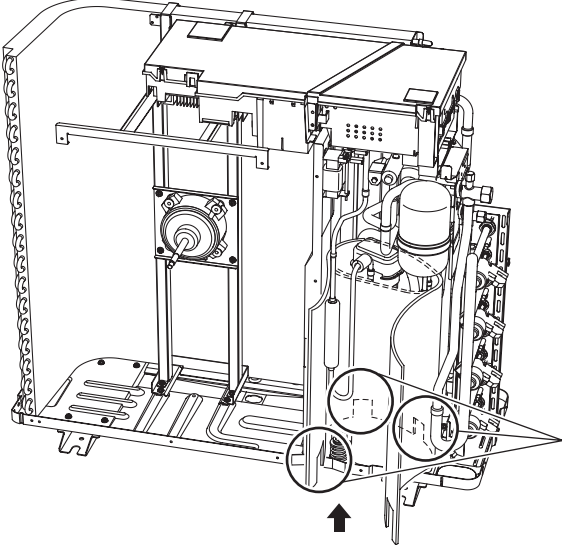
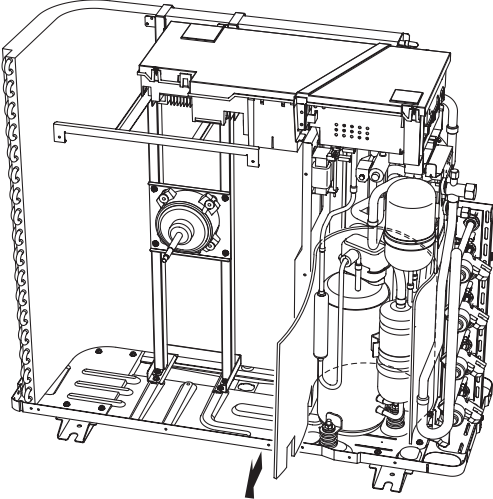
Step	Procedure	Points	
6	Remove the sound blanket (top lower).		<ul style="list-style-type: none"> ■ The sound blanket is fragile. Carefully pass the discharge pipe through it.
7	Open the sound blanket (inner sleeve) and remove part of the muffler.		<ul style="list-style-type: none"> ■ The sound blanket is fragile. Be careful of the notches of the compressor mount (3 locations).
8	Remove the sound blanket (outer sleeve).		

8. Removal of Compressor

Procedure

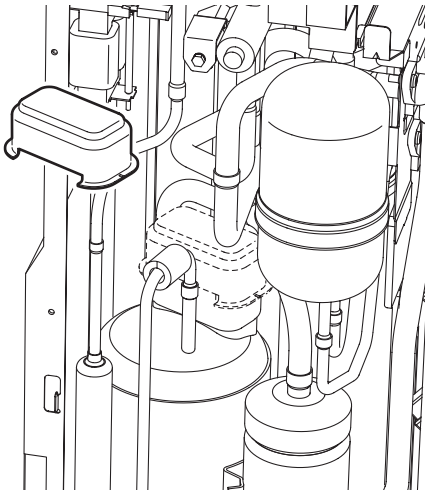
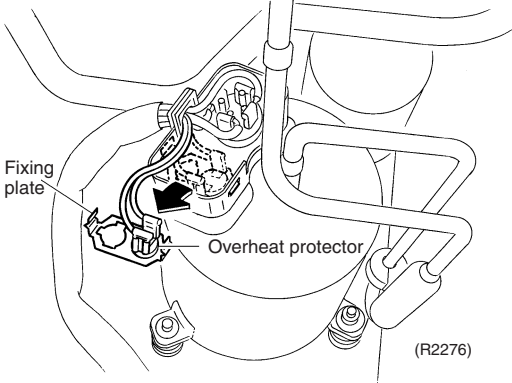

Warning Be sure to wait 10 minutes or more after turning off all power supplies before disassembling work.

Step	Procedure	Points
1	Remove the terminal cover.	
2	Pull out the 4 leads using long-nose pliers.	<p>■ U:red, V:yellow, W:blue, N:brown</p>
3	Remove the OL.	

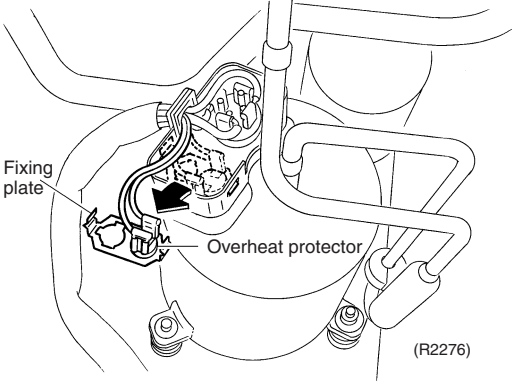
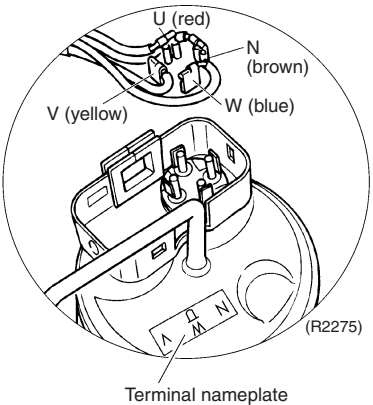

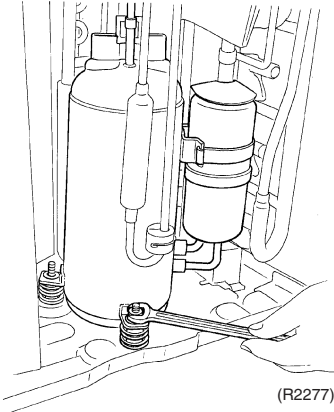
Step	Procedure	Procedure	Points
4	Remove the screw.	 <p>(R2277)</p>	

Revision History

Month / Year	Version	Revised contents
07 / 2013	Si12-795	First edition

Warning



- Daikin products are manufactured for export to numerous countries throughout the world. Prior to purchase, please confirm with your local authorised importer, distributor and/or retailer whether this product conforms to the applicable standards, and is suitable for use, in the region where the product will be used. This statement does not purport to exclude, restrict or modify the application of any local legislation.
- Ask a qualified installer or contractor to install this product. Do not try to install the product yourself. Improper installation can result in water or refrigerant leakage, electrical shock, fire or explosion.
- Use only those parts and accessories supplied or specified by Daikin. Ask a qualified installer or contractor to install those parts and accessories. Use of unauthorised parts and accessories or improper installation of parts and accessories can result in water or refrigerant leakage, electrical shock, fire or explosion.
- Read the User's Manual carefully before using this product. The User's Manual provides important safety instructions and warnings. Be sure to follow these instructions and warnings.

If you have any enquiries, please contact your local importer, distributor and/or retailer.

Cautions on product corrosion

1. Air conditioners should not be installed in areas where corrosive gases, such as acid gas or alkaline gas, are produced.
2. If the outdoor unit is to be installed close to the sea shore, direct exposure to the sea breeze should be avoided. If you need to install the outdoor unit close to the sea shore, contact your local distributor.

Dealer

DAIKIN INDUSTRIES, LTD.

Head Office:
Umeda Center Bldg., 2-4-12, Nakazaki-Nishi,
Kita-ku, Osaka, 530-8323 Japan

Tokyo Office:
JR Shinagawa East Bldg., 2-18-1, Konan,
Minato-ku, Tokyo, 108-0075 Japan

http://www.daikin.com/global_ac/

©All rights reserved