



REMOVAL PROCEDURE



S E R V I C E M A N U A L

2.5/3.5/5.0 kW Class

-  Indoor Unit
-  Inverter
-  Floor Standing Type

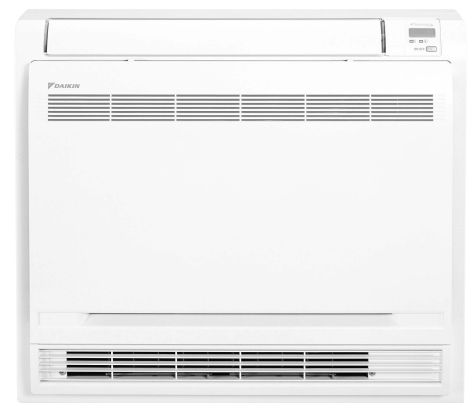

Service Manual Removal Procedure

Indoor Unit

●Cooling Only

**FVXS25FV1B
FVXS35FV1B
FVXS50FV1B**

●Heat Pump

**FVXS25FV1A
FVXS35FV1A
FVXS50FV1A**

**FVXS25FV1B
FVXS35FV1B
FVXS50FV1B**

Table of Contents

1. Removal of Air Filter / Front Panel / Front Grille	2
2. Removal of Horizontal Blade.....	6
3. Removal of Electrical Box	7
4. Removal of PCBs.....	9
5. Removal of Vertical Blades	13
6. Removal of Indoor Heat Exchanger	16
7. Removal of Fan Rotor / Fan Motor.....	17



Note: ♦ The illustrations may be slightly different depending on the model.

1. Removal of Air Filter / Front Panel / Front Grille

Procedure



Warning

Be sure to wait for 10 minutes or more after turning off all power supplies before disassembling work.

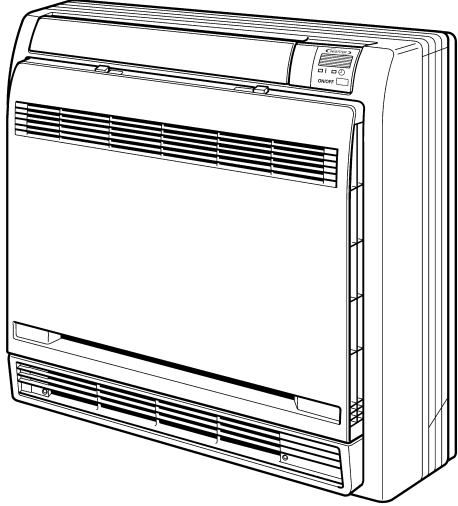
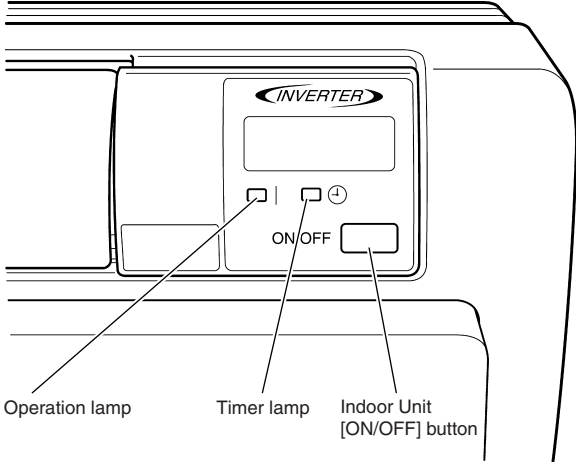
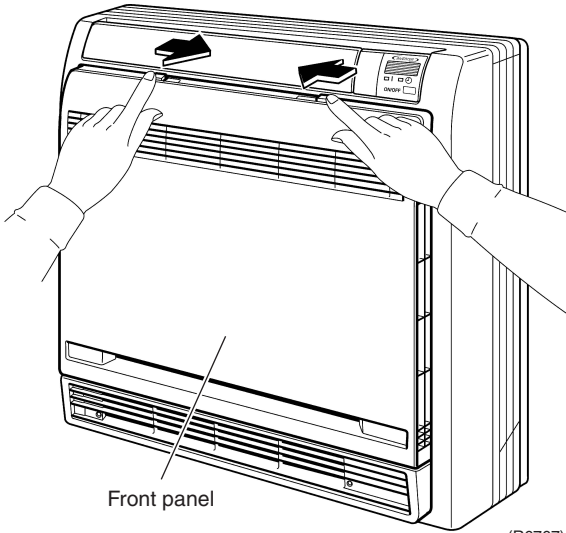
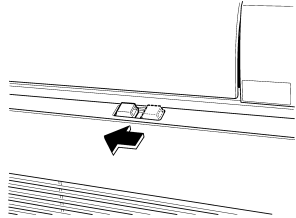
Step	Procedure	Points
<p>1. Features</p>	 <p>(R6765)</p>  <p>(R6766)</p>	
<p>2. Remove the front panel.</p> <p>1 Unfasten the 2 hooks on the top of the front panel.</p>	 <p>Front panel</p> <p>(R6767)</p>	 <p>(R6768)</p> <ul style="list-style-type: none"> Slide the right and the left hooks to the center.

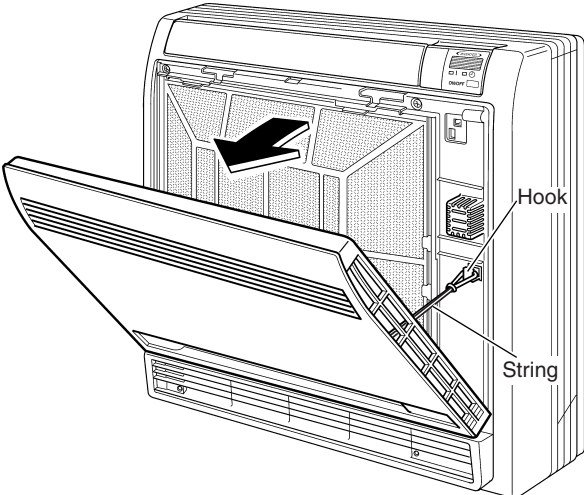
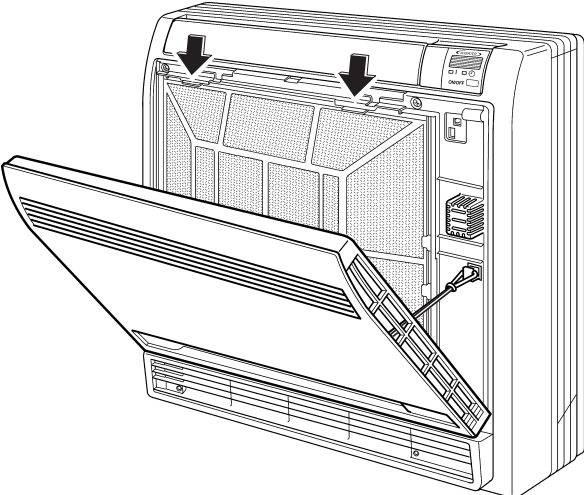
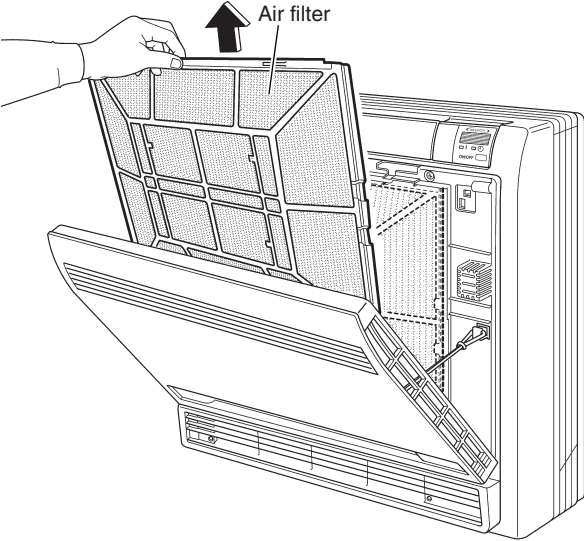
Step	Procedure	Points
2	<p data-bbox="201 215 443 241">Open the front panel.</p>  <p data-bbox="1007 757 1075 779">(R11496)</p>	
3	<p data-bbox="201 797 443 925">Press the 2 hooks of the top of the air filter downward and unfasten them.</p>  <p data-bbox="1007 1339 1075 1361">(R11497)</p>	
4	<p data-bbox="201 1424 443 1491">Pull the air filter up and remove it.</p>  <p data-bbox="1007 2033 1075 2056">(R11498)</p>	

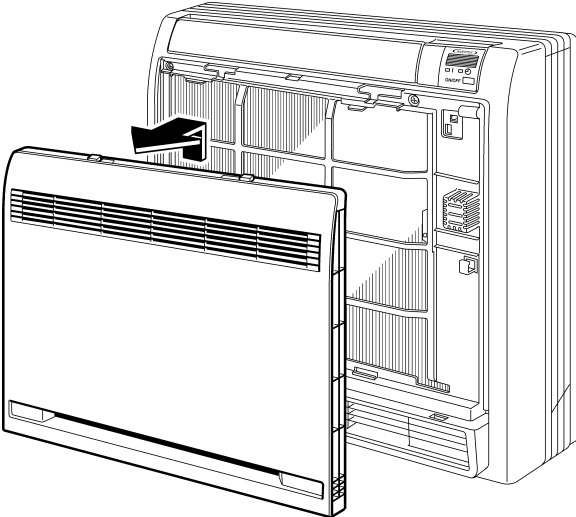
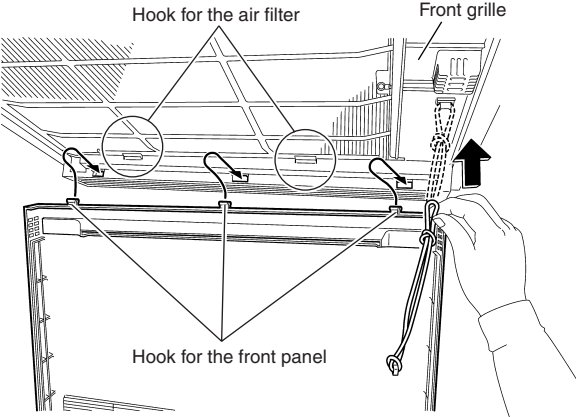
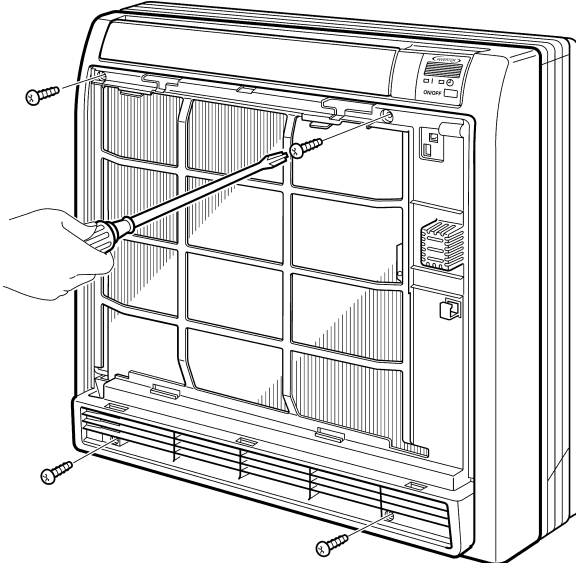
Step	Procedure	Points
<p>5 Release the string from the hook.</p> <p>6 Release the 3 hooks of the bottom of the front panel and remove the front panel.</p>	 <p>(R6772)</p>  <p>(R17116)</p>	<ul style="list-style-type: none"> ■ When installing the air filter, catch the 2 hooks of the front grille. ■ When installing the front panel, catch the 3 hooks of the front grille and hitch the string to prevent the front panel from dropping.
<p>7 Remove the 4 screws from the front grille.</p>	 <p>(R6774)</p>	

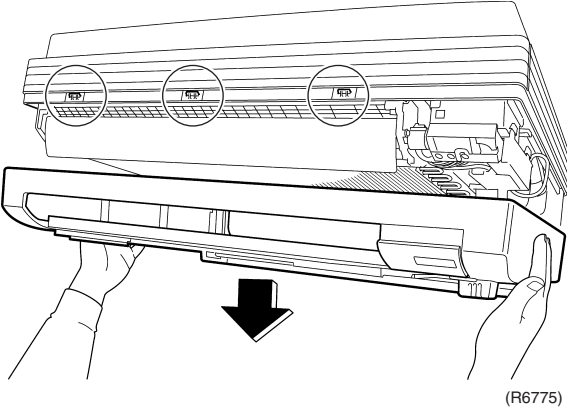
Step	Procedure	Points
8	Pull the front grille to your side to remove.	■ There are 3 hooks on the top of the main unit.
 <p>(R6775)</p>		

2. Removal of Horizontal Blade

Procedure



Warning

Be sure to wait for 10 minutes or more after turning off all power supplies before disassembling work.

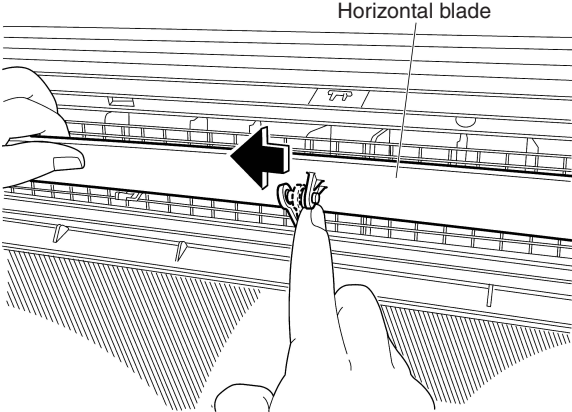
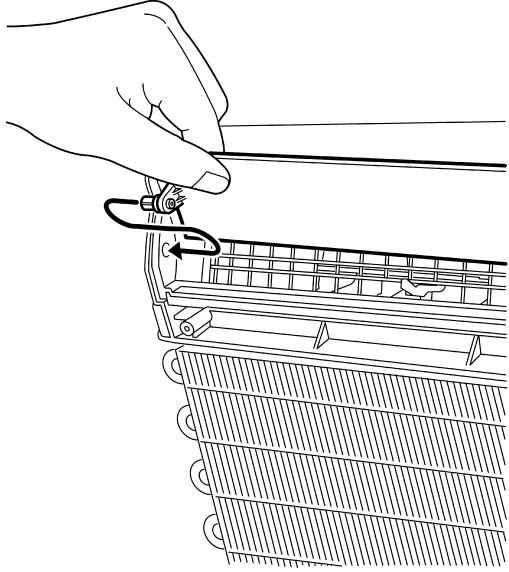
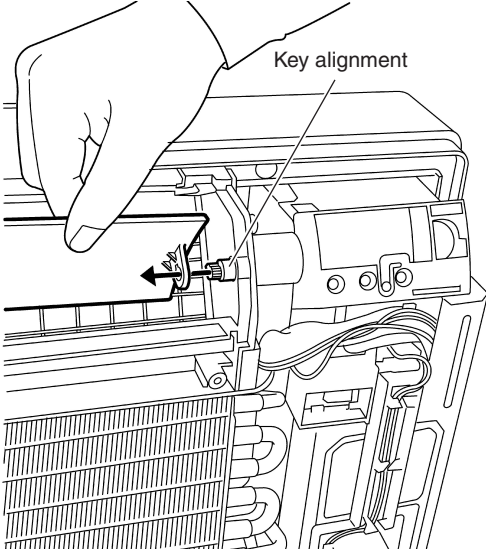
Step	Procedure	Points
<p>1 Open the horizontal blade.</p> <p>2 Release the center shaft.</p>	 <p style="text-align: right;">(R6778)</p>	
<p>3 Bend the horizontal blade to release the right and the left shafts and remove the horizontal blade.</p>	 <p style="text-align: right;">(R6779)</p>  <p style="text-align: right;">(R6780)</p>	<p>■ Release the left shaft first and then release the right shaft from the key alignment.</p>

3. Removal of Electrical Box

Procedure



Warning Be sure to wait for 10 minutes or more after turning off all power supplies before disassembling work.

Step	Procedure	Points
1	Remove the 2 earth wire screws.	
2	Unfasten the hook and lift the sensor PCB fixing plate.	
3	Remove the front shield plate.	
4	To detach the connection wires, remove the screw from the wiring fixture and remove the 4 screws from the terminal board.	

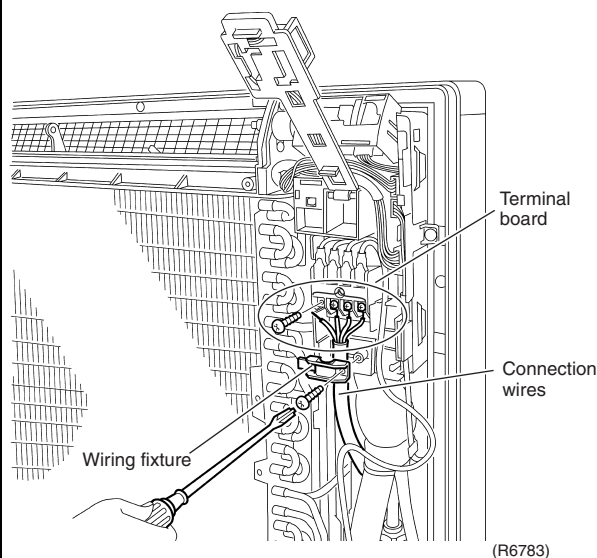
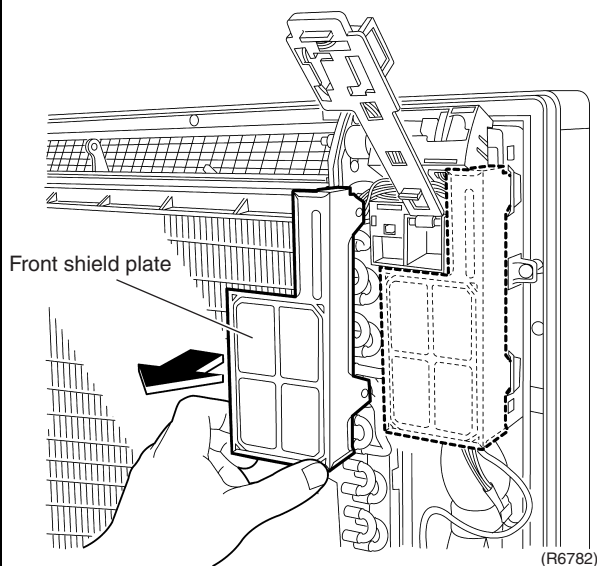
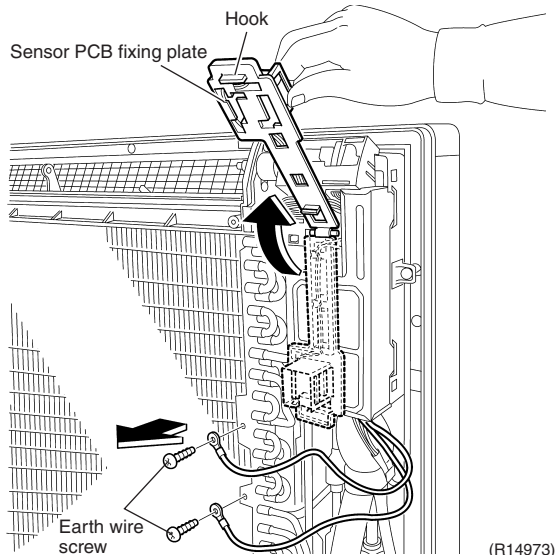

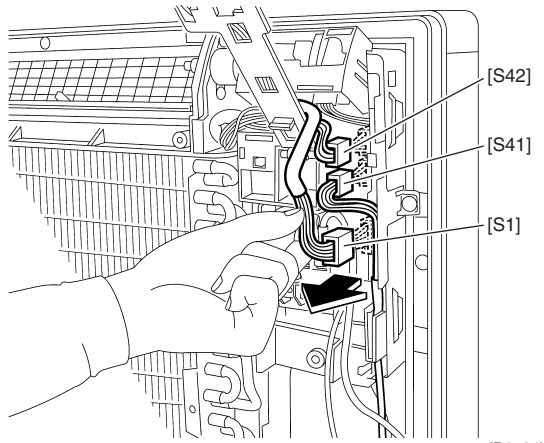
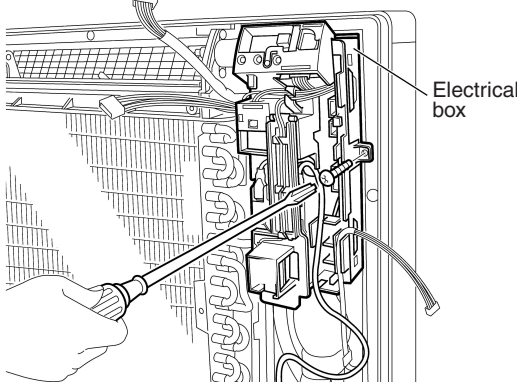
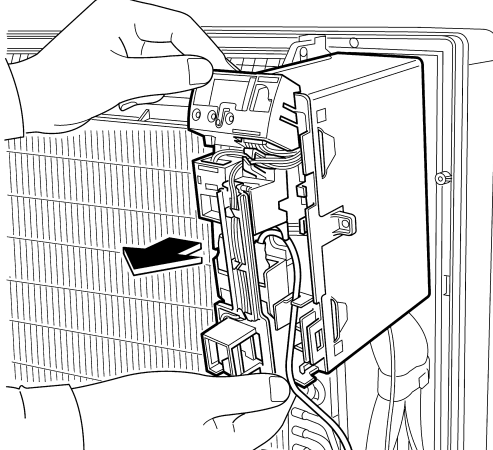
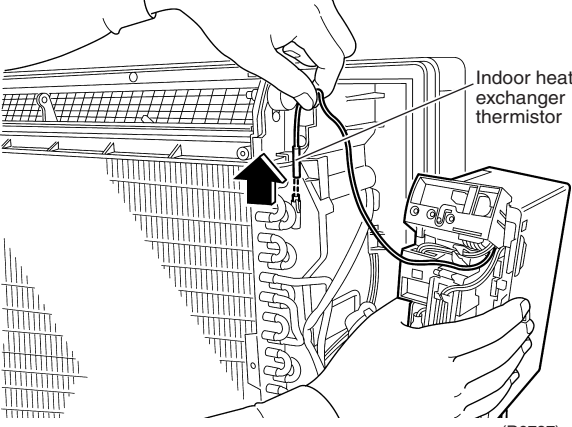
Step	Procedure	Points	
5	Disconnect the 3 connectors [S1] [S41] [S42].	 <p>(R6784)</p>	[S1] : fan motor [S41]: lower air outlet motor [S42]: swing motor
6	Remove the screw of the electrical box.	 <p>(R6785)</p>	
7	Pull out the electrical box.	 <p>(R6786)</p>	
8	Pull out the indoor heat exchanger thermistor.	 <p>(R6787)</p>	

4. Removal of PCBs

Procedure



Warning

Be sure to wait for 10 minutes or more after turning off all power supplies before disassembling work.

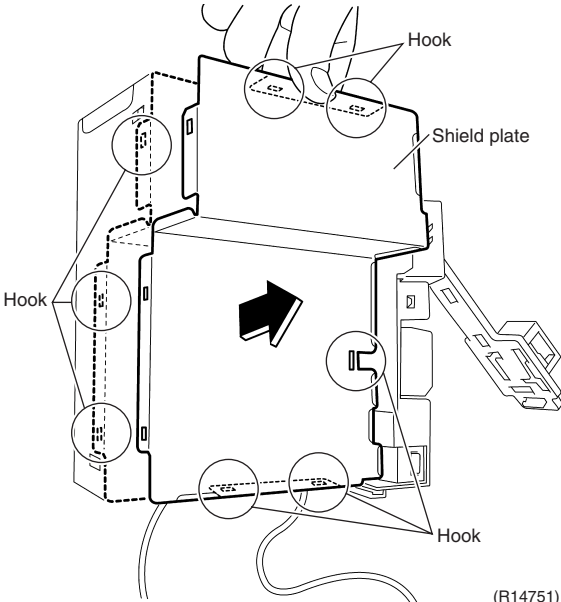
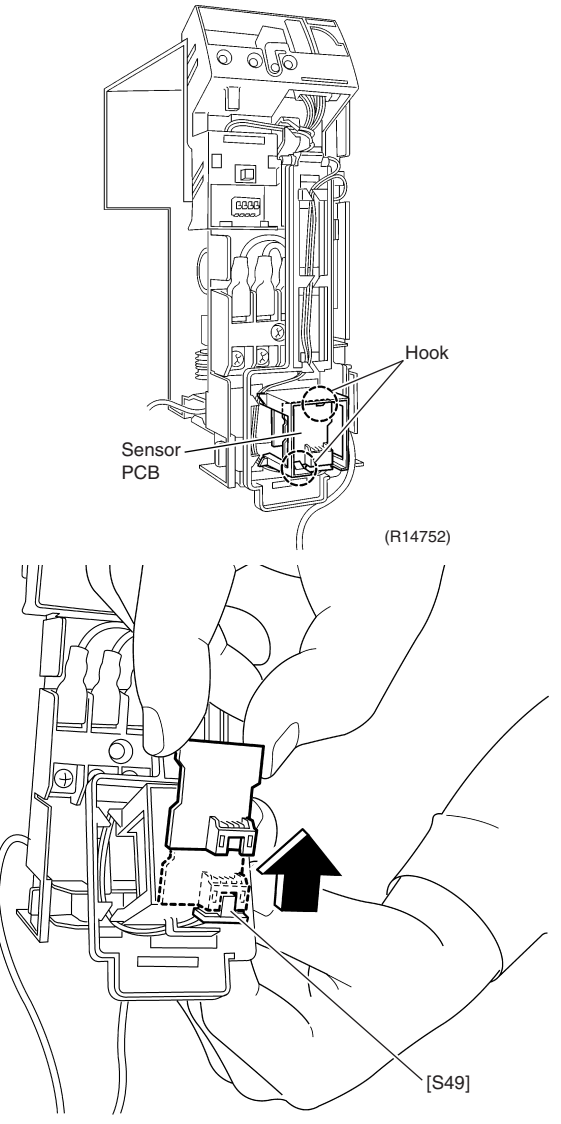
Step	Procedure	Points
1. Remove the shield plate. 1 Unfasten the 8 hooks of the shield plate and remove it.		
2. Remove the sensor PCB. 1 Unfasten the 2 hooks of the sensor PCB. 2 Disconnect the connector [S49] and remove the sensor PCB.		

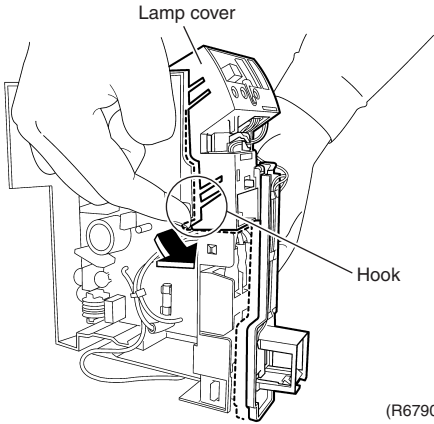
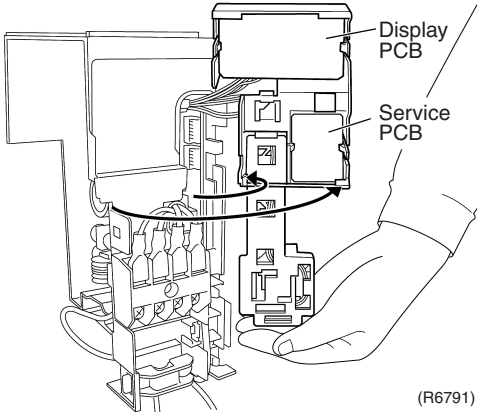
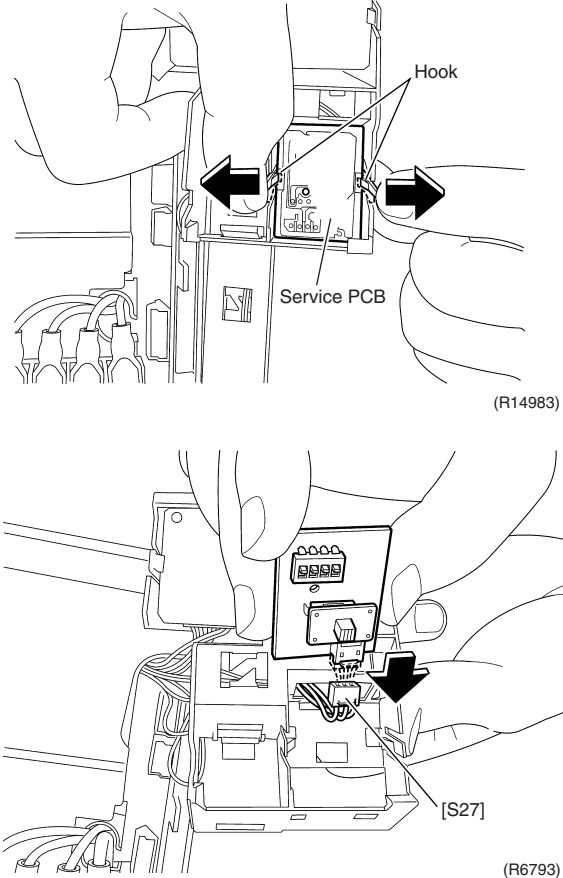
Step	Procedure	Points
<p>3. Remove the service PCB.</p>	<p>1 Unfasten the 2 hooks of the lamp cover.</p>  <p>(R6790)</p> <p>2 Unfasten the 2 hooks of the service PCB.</p>  <p>(R6791)</p> <p>3 Disconnect the connector [S27] and remove the service PCB.</p>  <p>(R14983)</p> <p>(R6793)</p>	<p>■ Unfasten the left hook first.</p>

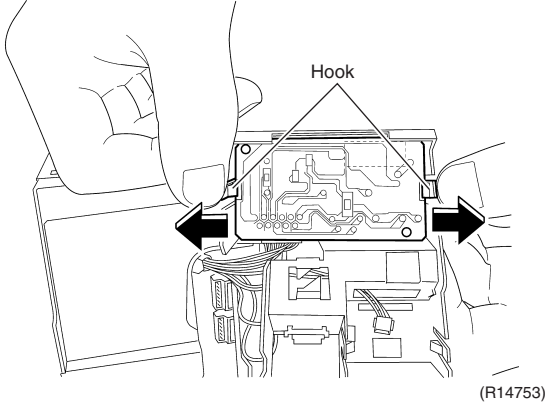
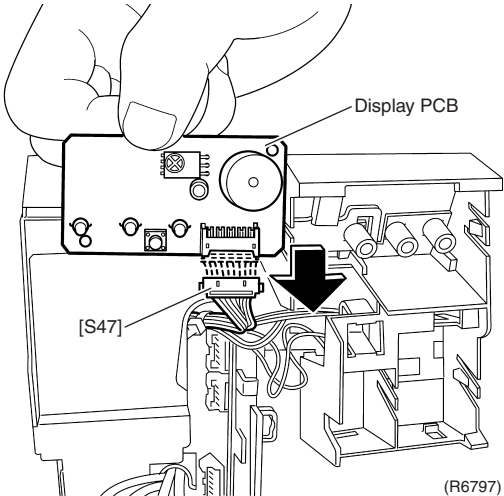
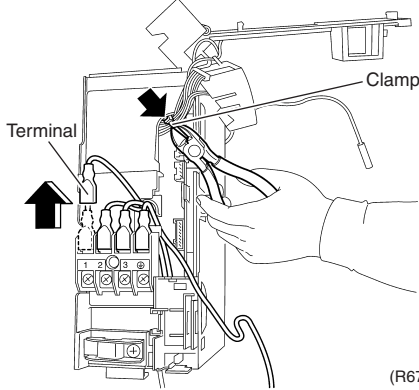
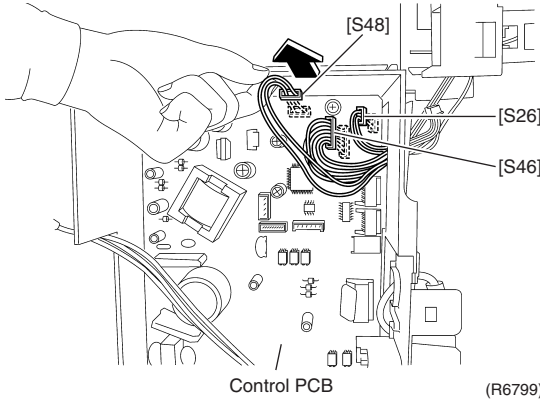
Step	Procedure	Points
4. Remove the display PCB.	<p>1 Unfasten the 2 hooks of the display PCB.</p>  <p>2 Disconnect the connector [S47] and remove the display PCB.</p> 	
5. Remove the control PCB.	<p>1 Cut the clamp and pull out all the terminals from the terminal board.</p>  <p>2 Disconnect the connectors [S26] [S46] [S48].</p> 	<p>[S26]: service PCB [S46]: display PCB [S48]: sensor PCB</p>

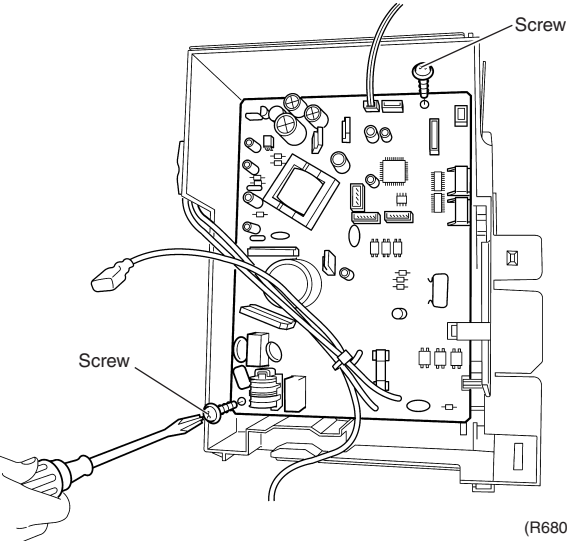
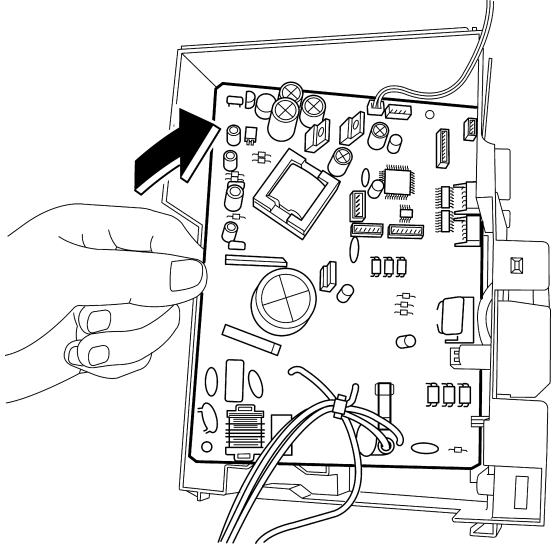
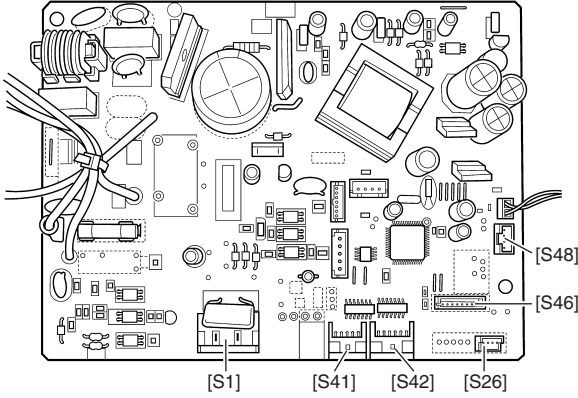
Step	Procedure	Points
3	<p>Remove the 2 screws.</p>  <p>(R6800)</p>	
4	<p>Remove the control PCB.</p>  <p>(R6801)</p>  <p>(R14974)</p>	

5. Removal of Vertical Blades

Procedure



Warning

Be sure to wait for 10 minutes or more after turning off all power supplies before disassembling work.

Step	Procedure	Points
1. Remove the vertical blade (upper).		
1 Remove the 2 screws and remove the air outlet ASSY.		
2 The air outlet ASSY has the 2 vertical blades ASSYs.		
3 Unfasten the 2 hooks and the center hook to remove the vertical blades ASSY.		
4 Slide the protection net along the right and the left grooves and remove it.		

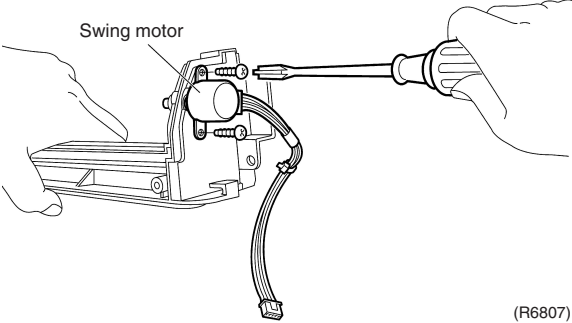
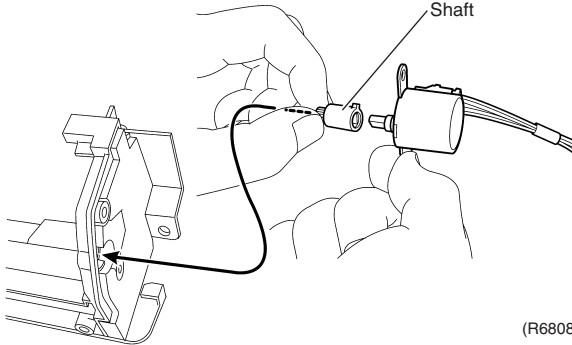
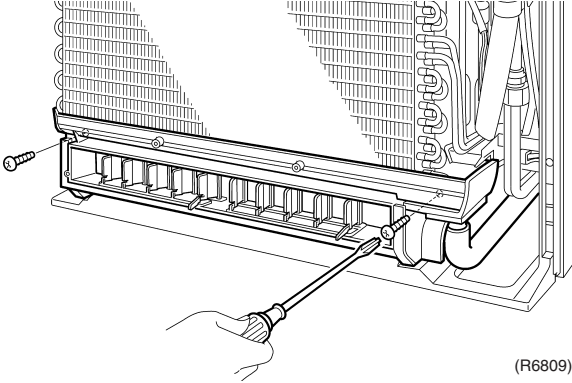
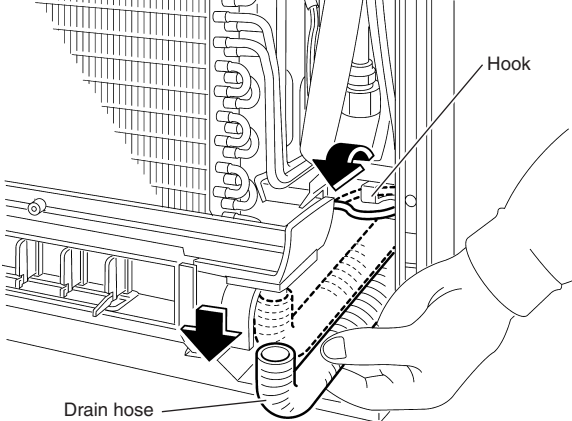
Step	Procedure	Points
5	<p>Remove the 2 screws to remove the swing motor.</p>  <p>Swing motor</p> <p>(R6807)</p>  <p>Shaft</p> <p>(R6808)</p>	
2.	<p>Remove the vertical blade (lower).</p>	<p>■ Be careful not to wet the floor with drained water.</p>
1	<p>Remove the 2 screws.</p>  <p>(R6809)</p>	
2	<p>Remove the drain hose and release the harness of the lower air outlet motor from the hook.</p>  <p>Hook</p> <p>Drain hose</p> <p>(R6810)</p>	

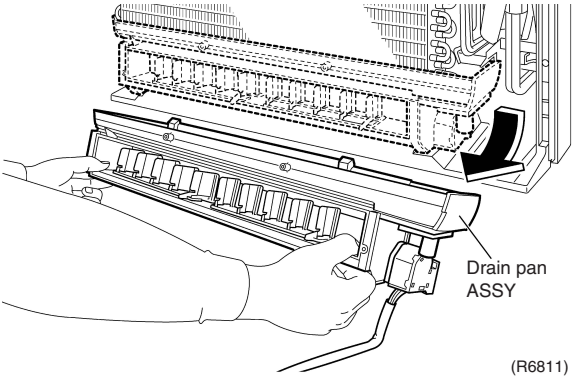
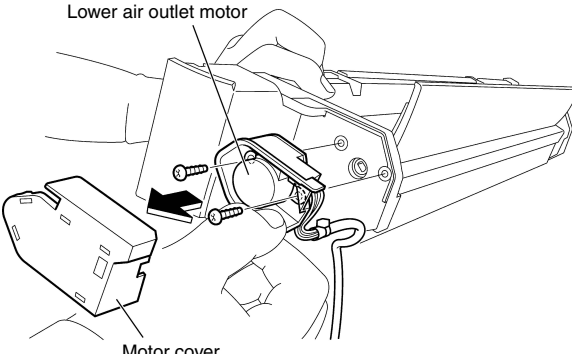
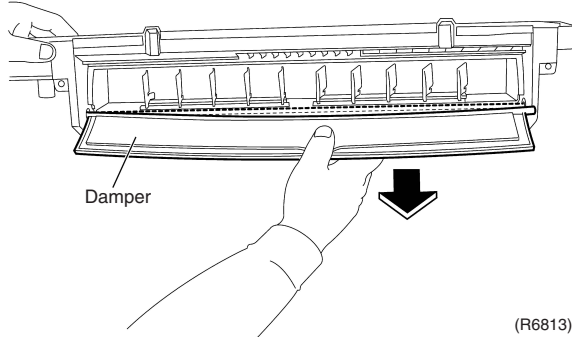
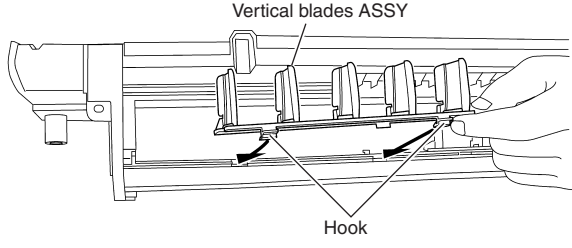
Step		Procedure	Points
3	Pull out the drain pan ASSY.	 <p>(R6811)</p>	
4	Remove the motor cover. Remove the 2 screws to remove the lower air outlet motor.	 <p>(R6812)</p>	
5	Remove the damper.	 <p>(R6813)</p>	
6	Remove the sealing material from the front of the vertical blades ASSY, unfasten the 2 hooks from the drain pan, and remove the vertical blades ASSY.	 <p>(R14756)</p>	

6. Removal of Indoor Heat Exchanger

Procedure



Warning

Be sure to wait for 10 minutes or more after turning off all power supplies before disassembling work.

Step	Procedure	Points
<p>■ Make sure that the refrigerant gas is removed after the pump down work.</p>	<p>(R11499)</p>	<p>Caution</p> <p>When removing or reassembling the indoor heat exchanger, be sure to wear gloves or wrap the indoor heat exchanger with cloth before proceeding to the work. (You may be injured by the fins.)</p>
<p>1 Release the flared joint of the liquid pipe and the gas pipe using 2 wrenches.</p>	<p>Piping fixture</p> <p>(R11502)</p>	<p>Left hook</p> <p>Right hook</p> <p>(R9994)</p>
<p>2 Remove the piping fixture.</p>	<p>Hook</p> <p>Indoor heat exchanger</p> <p>(R14975)</p>	<p>Hook</p> <p>Hook</p> <p>(R11501)</p>
<p>3 Unfasten the 2 hooks on the left side of the indoor heat exchanger.</p>		
<p>4 Unfasten the 2 hooks on the right side and remove the indoor heat exchanger.</p>		

7. Removal of Fan Rotor / Fan Motor

Procedure



Warning

Be sure to wait for 10 minutes or more after turning off all power supplies before disassembling work.

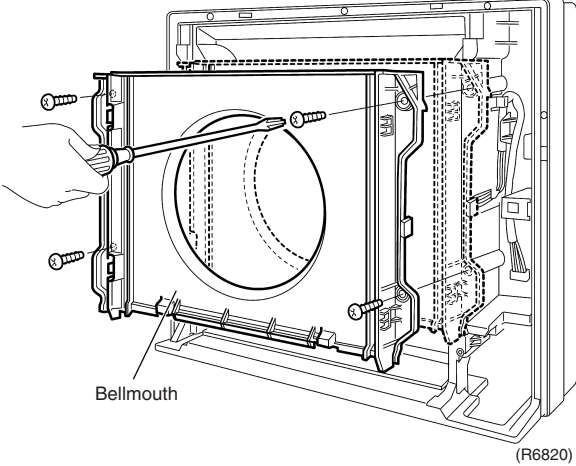
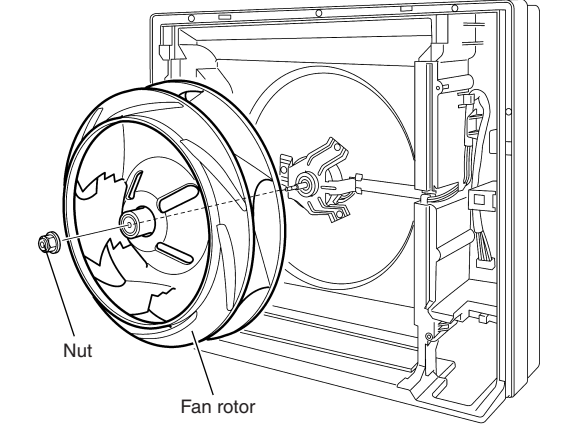
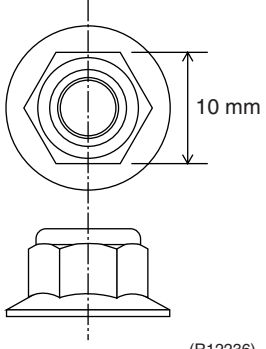
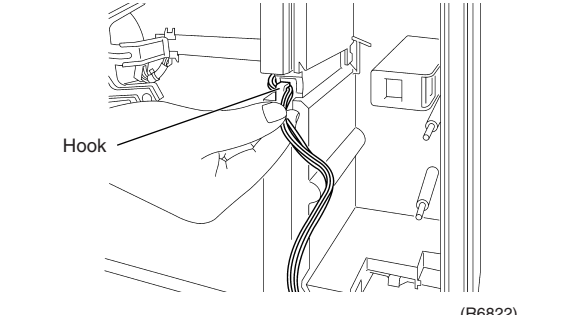
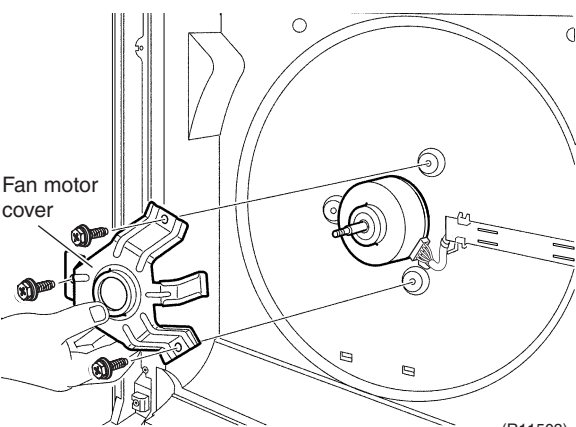
Step	Procedure	Points
<p>1. Remove the fan rotor.</p> <p>1 Remove the 4 screws and remove the bellmouth.</p> <p>2 Remove the nut to remove the fan rotor.</p>	 <p style="text-align: right;">(R6820)</p>  <p style="text-align: right;">(R6821)</p>	<p>■ Nut size: M6</p>  <p style="text-align: right;">(R12236)</p>
<p>2. Remove the fan motor.</p> <p>1 Release the harness of the fan motor from the hook.</p> <p>2 Remove the 3 screws and remove the fan motor cover.</p>	 <p style="text-align: right;">(R6822)</p>  <p style="text-align: right;">(R11503)</p>	

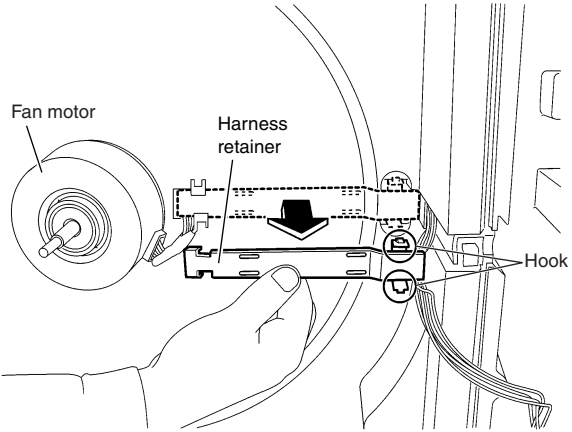
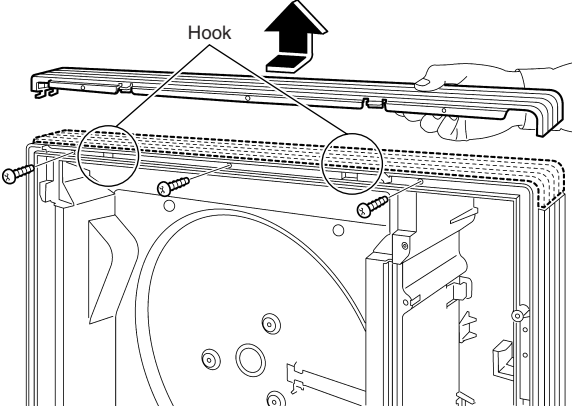
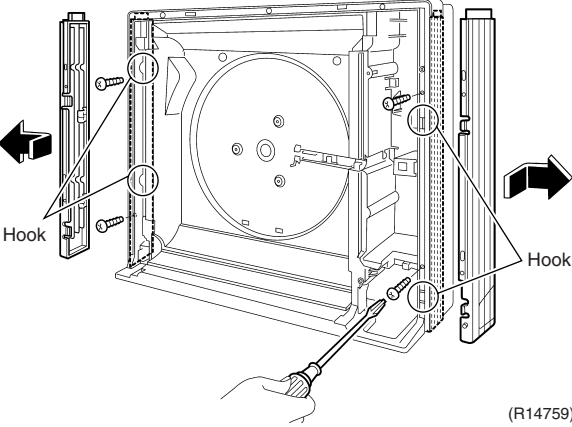
Step	Procedure	Points
3	<p>Unfasten the 2 hooks to remove the harness retainer and remove the fan motor.</p>  <p>(R14976)</p>	
<p>3. Remove the casing.</p> <p>1</p>	<p>Remove 3 screws and unfasten the 2 hooks to remove the upper casing.</p>  <p>(R14758)</p>	<ul style="list-style-type: none"> ■ Press the 2 hooks toward the back side and remove the casing.
2	<p>Remove 2 screws and unfasten the 2 hooks to remove the right casing or the left casing.</p>  <p>(R14759)</p>	<ul style="list-style-type: none"> ■ Press the 2 hooks toward the back side and remove the casing.

Revision History

Month / Year	Version	Revised contents
07 / 2013	Si06-759	First edition

Warning



- Daikin products are manufactured for export to numerous countries throughout the world. Prior to purchase, please confirm with your local authorised importer, distributor and/or retailer whether this product conforms to the applicable standards, and is suitable for use, in the region where the product will be used. This statement does not purport to exclude, restrict or modify the application of any local legislation.
- Ask a qualified installer or contractor to install this product. Do not try to install the product yourself. Improper installation can result in water or refrigerant leakage, electrical shock, fire or explosion.
- Use only those parts and accessories supplied or specified by Daikin. Ask a qualified installer or contractor to install those parts and accessories. Use of unauthorised parts and accessories or improper installation of parts and accessories can result in water or refrigerant leakage, electrical shock, fire or explosion.
- Read the User's Manual carefully before using this product. The User's Manual provides important safety instructions and warnings. Be sure to follow these instructions and warnings.

If you have any enquiries, please contact your local importer, distributor and/or retailer.

Cautions on product corrosion

1. Air conditioners should not be installed in areas where corrosive gases, such as acid gas or alkaline gas, are produced.
2. If the outdoor unit is to be installed close to the sea shore, direct exposure to the sea breeze should be avoided. If you need to install the outdoor unit close to the sea shore, contact your local distributor.

Dealer

DAIKIN INDUSTRIES, LTD.

Head Office:
Umeda Center Bldg., 2-4-12, Nakazaki-Nishi,
Kita-ku, Osaka, 530-8323 Japan

Tokyo Office:
JR Shinagawa East Bldg., 2-18-1, Konan,
Minato-ku, Tokyo, 108-0075 Japan

http://www.daikin.com/global_ac/

©All rights reserved