



REMOVAL PROCEDURE



S E R V I C E M A N U A L

2.5/3.5 kW Class

-  Indoor Unit
-  Inverter
-  Wall Mounted Type



Service Manual Removal Procedure

Indoor Unit

●Heat Pump

FTXG25JV1BW

FTXG35JV1BW

FTXG25JV1BS

FTXG35JV1BS

Table of Contents

1. Removal of Air Filters / Front Panel	2
2. Removal of Horizontal Blades	6
3. Removal of Front Grille	8
4. Removal of Front Panel Mechanism ASSY	11
5. Removal of Display Lens ASSY	13
6. Removal of Reduction Motor / Limit Switch	14
7. Removal of Fan Guards / Electrical Box	16
8. Removal of PCBs	19
9. Removal of Swing Motors	25
10. Removal of Indoor Heat Exchanger	26
11. Removal of Fan Rotor / Fan Motor	29
12. Removal of Vertical Blade ASSYs	32



Note: ♦ The illustrations may be slightly different depending on the model.

1. Removal of Air Filters / Front Panel

Procedure



Warning

Be sure to wait for 10 minutes or more after turning off all power supplies before disassembling work.

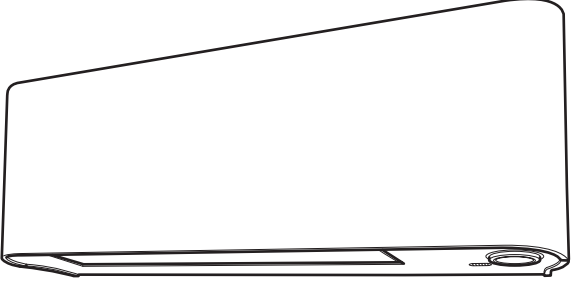
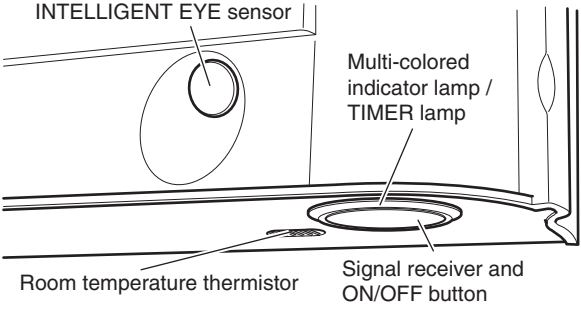
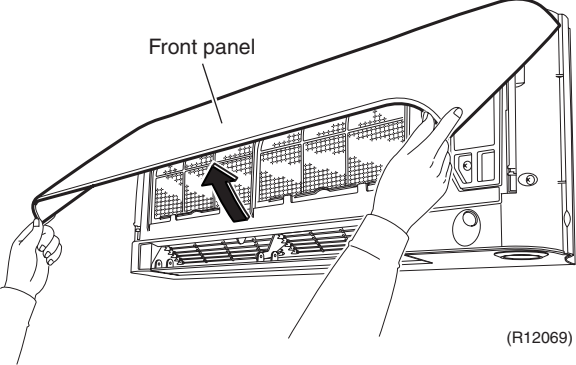
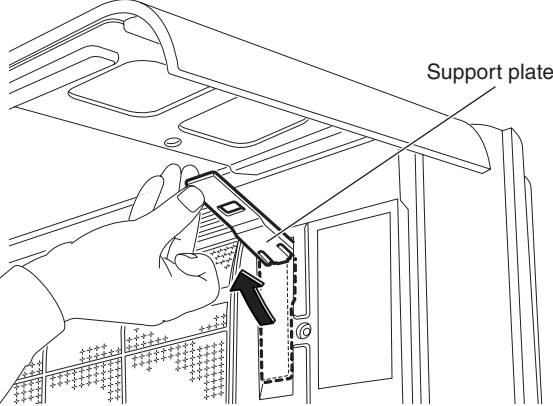
Step	Procedure	Points
1. Appearance feature	 <p>(R12067)</p>  <p>(R12068)</p>	
2. Remove the air filters.	<p>1 Open the front panel.</p>  <p>(R12069)</p> <p>2 Keep the front panel open with the support plate.</p>  <p>(R12070)</p>	

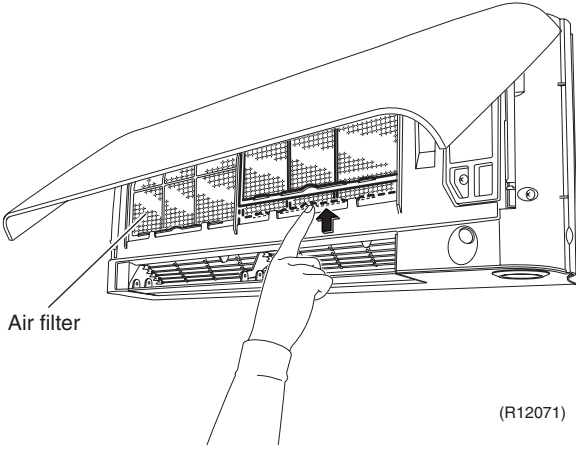
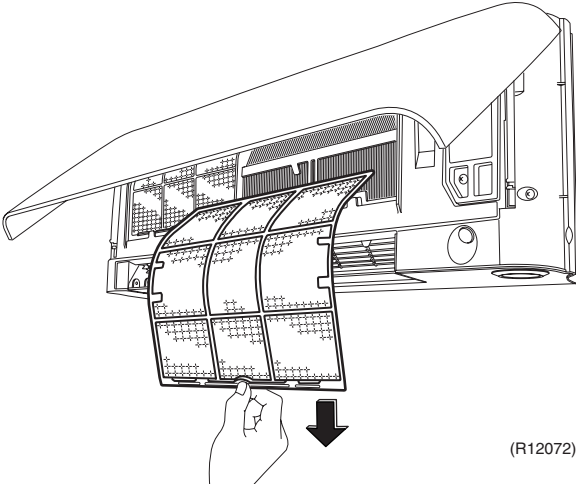
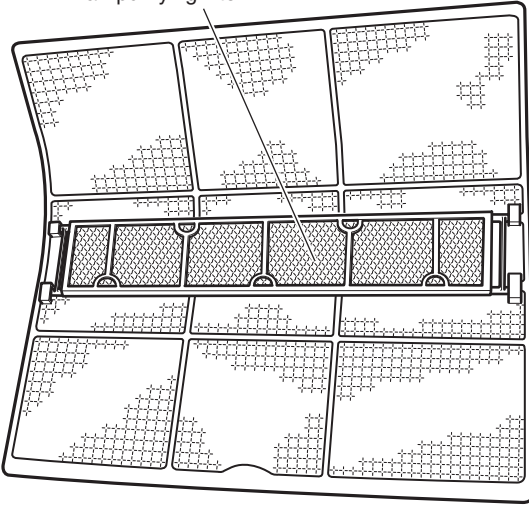
Step	Procedure	Points
<p>3</p>	<p>Lift the air filter upwards slightly, and then pull it out downwards.</p>  <p>Air filter</p> <p>(R12071)</p>  <p>(R12072)</p>	<ul style="list-style-type: none"> ■ The air filter is not marked for difference between the right and left sides. ■ The air filter can be set easily by inserting it along the guides. ■ Be sure to insert the hooks (at 2 lower positions) when mounting the air filter.
<p>3.</p>	<p>Remove the Titanium apatite photocatalytic air-purifying filter.</p>  <p>Titanium apatite photocatalytic air-purifying filter</p> <p>(R12073)</p>	<ul style="list-style-type: none"> ■ The Titanium apatite photocatalytic air-purifying filter is not marked for difference between the right and left sides.
<p>1</p>	<p>The Titanium apatite photocatalytic air-purifying filter is attached to the rear of the air filter.</p>	

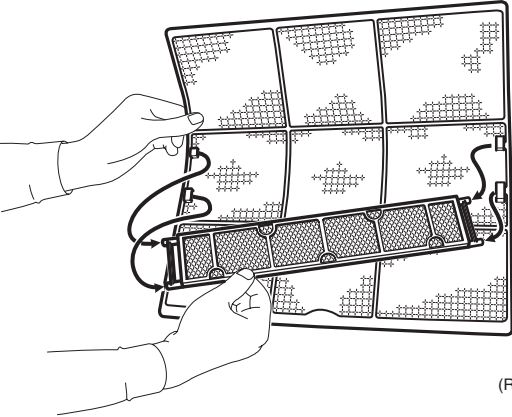
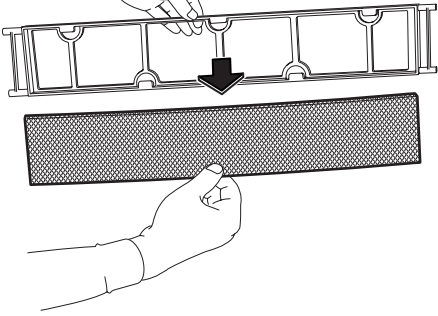
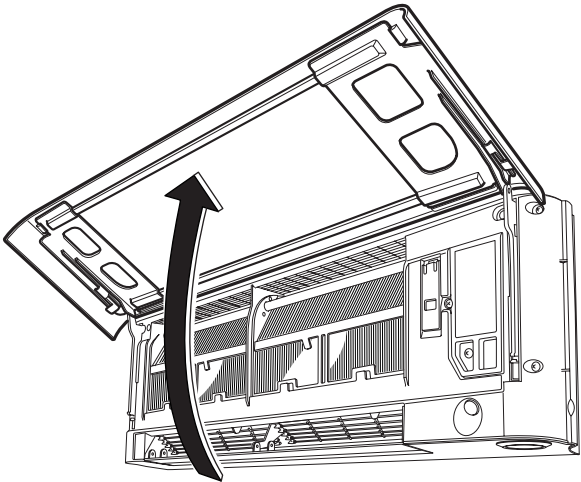
Step	Procedure	Points
2	<p>Release the protrusions and remove the Titanium apatite photocatalytic air-purifying filter frame.</p>  <p>(R15282)</p>	
3	<p>Remove the Titanium apatite photocatalytic air-purifying filter.</p>  <p>(R12074)</p>	
4.	<p>Remove the front panel.</p>	
1	<p>Open the front panel.</p>  <p>(R12075)</p>	

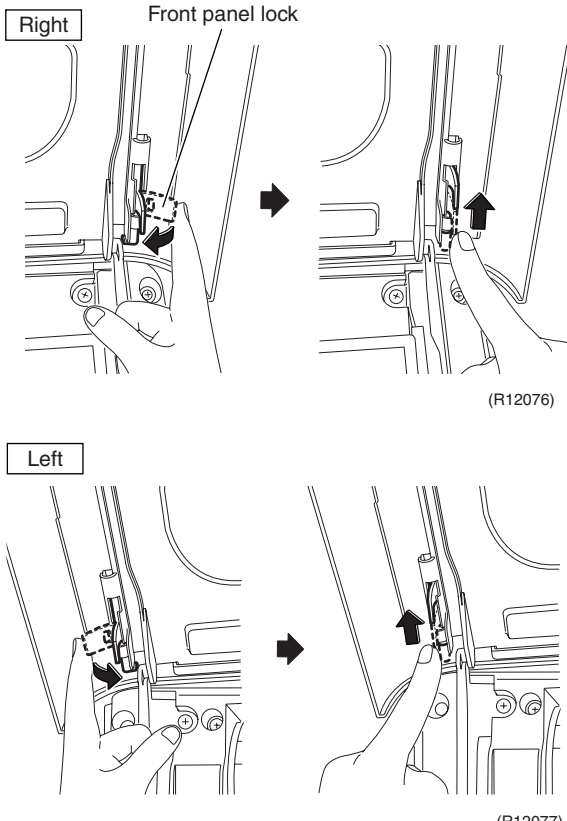
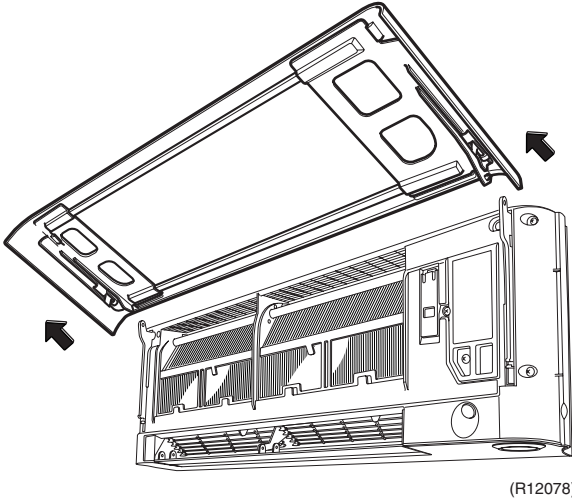
Step	Procedure	Points
2	<p>Release the front panel locks on each side.</p> 	
3	<p>Remove the front panel.</p> 	

2. Removal of Horizontal Blades

Procedure



Warning

Be sure to wait for 10 minutes or more after turning off all power supplies before disassembling work.

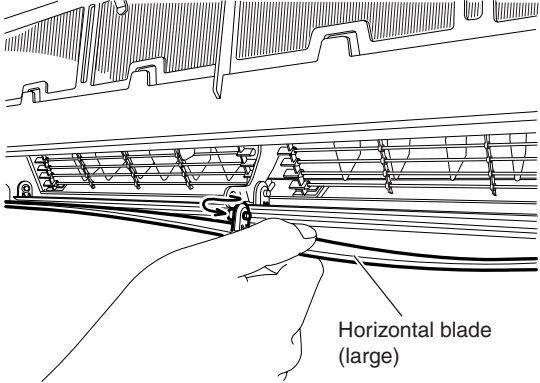
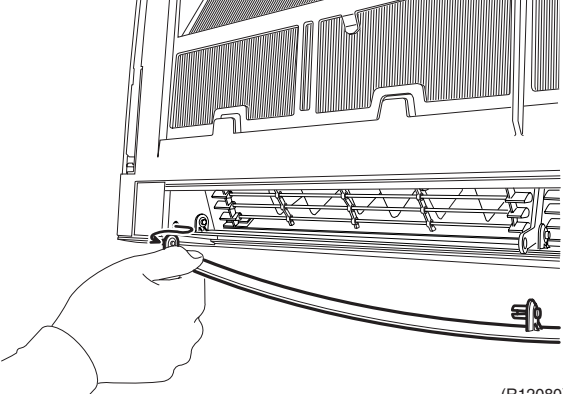
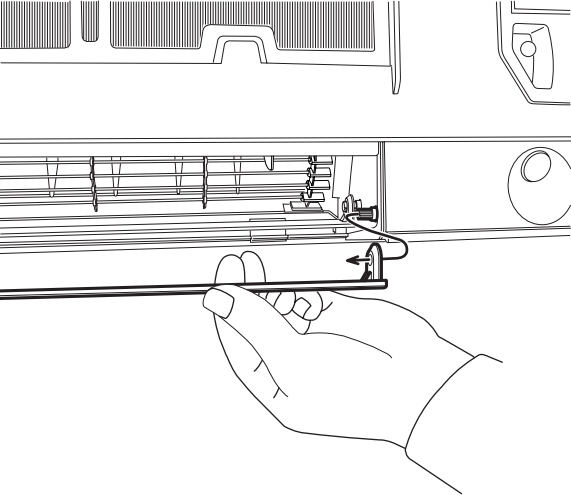
Step	Procedure	Points
1.	Remove the horizontal blade (large).	
1	Bend the horizontal blade (large) slightly and release the center shaft.  <p style="text-align: right;">(R12079)</p>	
2	Release the left shaft.  <p style="text-align: right;">(R12080)</p>	
3	Slide the horizontal blade (large) to the left and release the right shaft.  <p style="text-align: right;">(R12081)</p>	

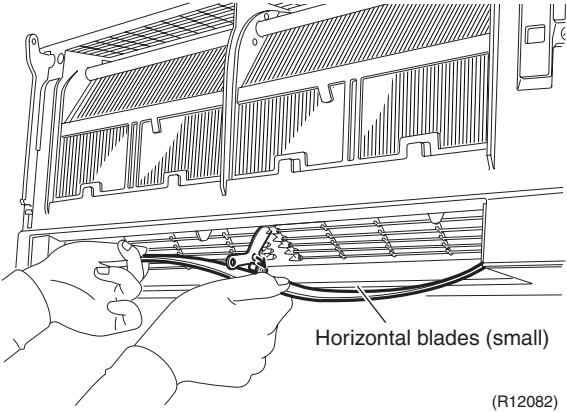
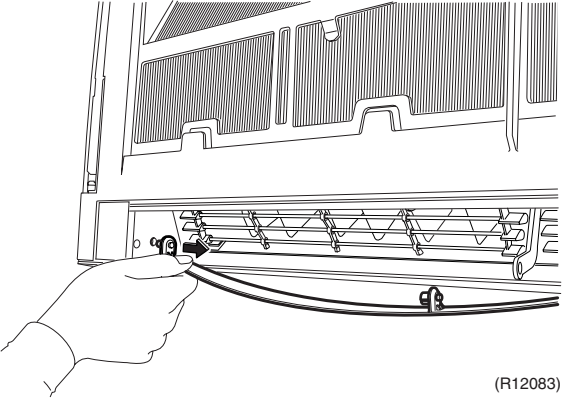
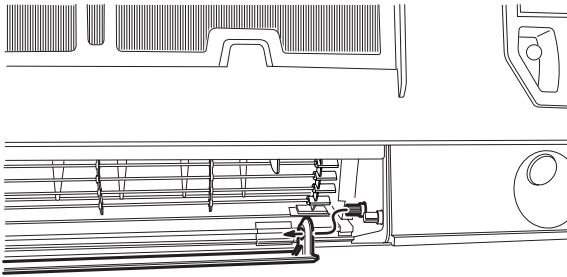
Step	Procedure	Points
2.	Remove the horizontal blade (small).	
1	<p>Bend the horizontal blade (small) slightly and release the center shaft.</p>  <p>Horizontal blades (small)</p> <p>(R12082)</p>	
2	<p>Release the left shaft.</p>  <p>(R12083)</p>	
3	<p>Slide the horizontal blade (small) to the left and release the right shaft.</p>  <p>(R12084)</p>	

3. Removal of Front Grille

Procedure



Warning

Be sure to wait for 10 minutes or more after turning off all power supplies before disassembling work.

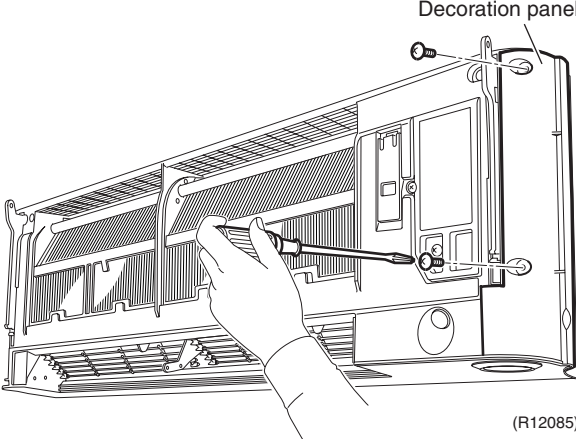
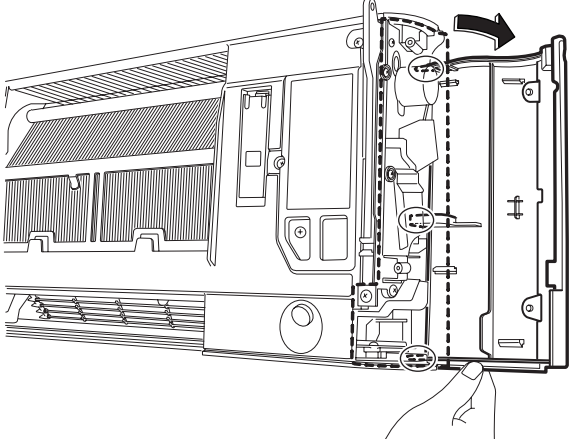
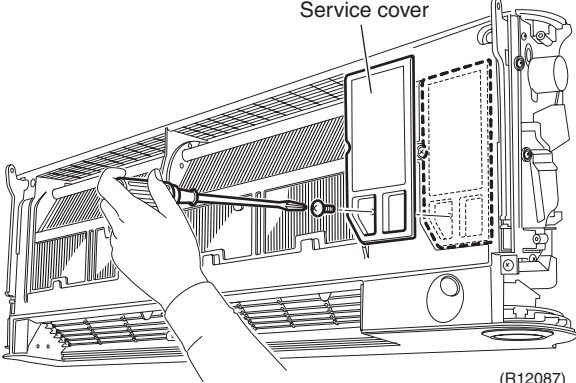
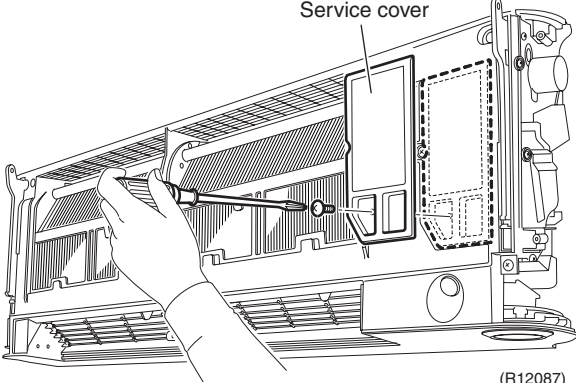
Step	Procedure	Points
1	<p>Remove the 2 screws of the decoration panel (right).</p>  <p style="text-align: right;">(R12085)</p>	
2	<p>Open the decoration panel (right). Unfasten the 3 hooks and remove it.</p>  <p style="text-align: right;">(R12086)</p>	
3	<p>Remove the decoration panel (left) in the same way.</p>  <p style="text-align: right;">(R12087)</p>	
4	<p>Remove the screw and remove the service cover.</p>  <p style="text-align: right;">(R12087)</p>	

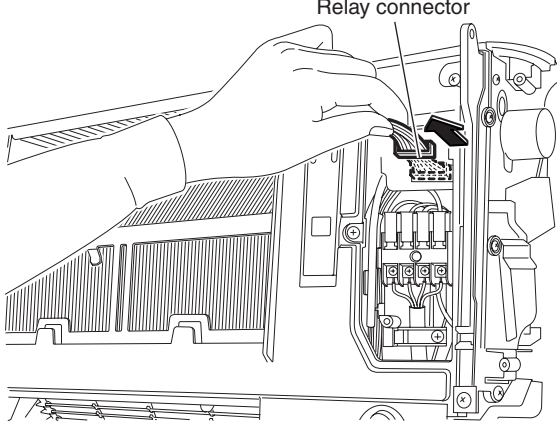
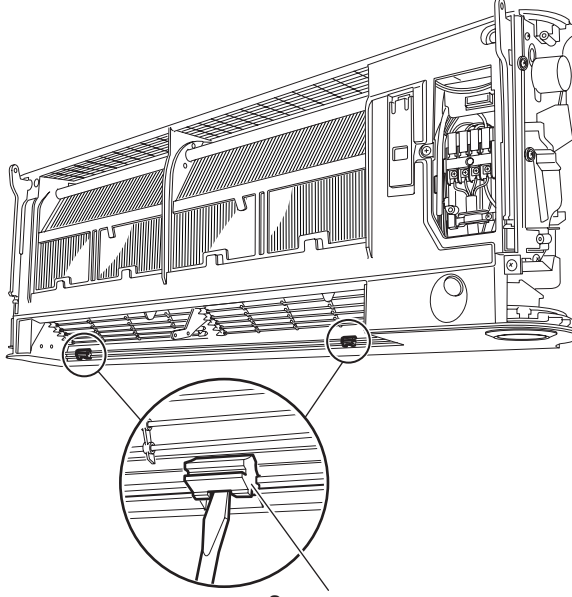
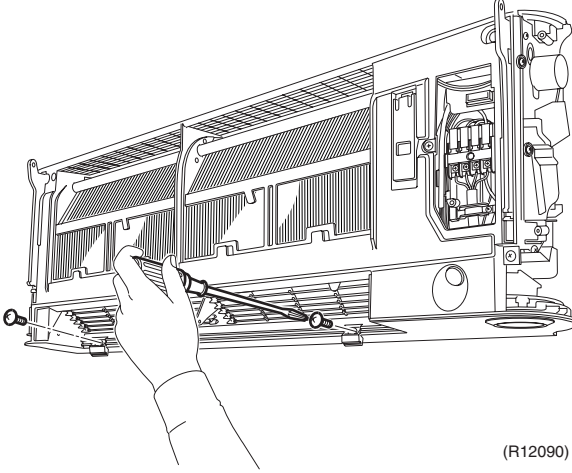
Step	Procedure	Procedure	Points
5	Disconnect the relay connector for the reduction motor.	 <p>Relay connector</p> <p>(R12088)</p>	
6	Open the 2 screw covers with a flat screwdriver.	 <p>Screw cover</p> <p>(R12089)</p>	
7	Remove the 2 screws.	 <p>(R12090)</p>	

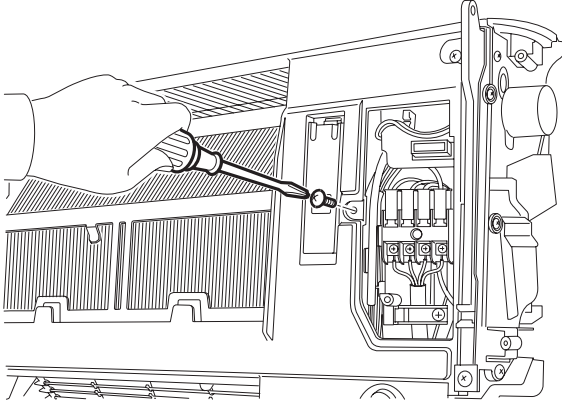
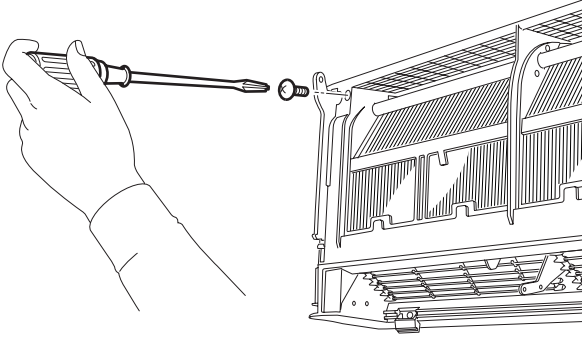
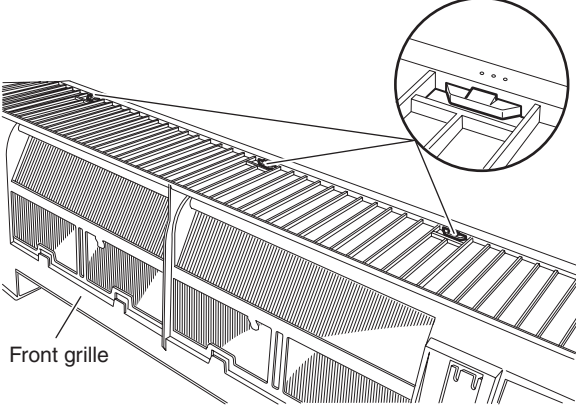
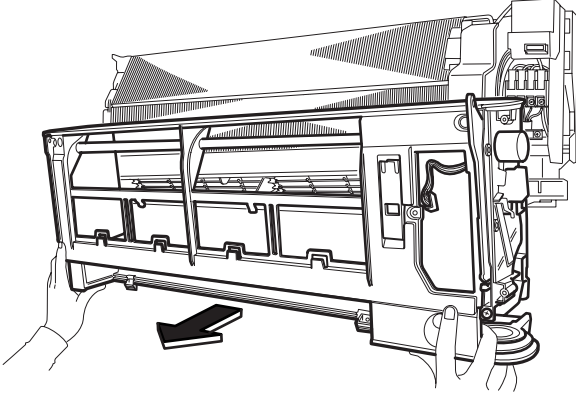
Step	Procedure	Points
8	Remove the screw.	
	 <p>(R12091)</p>	
9	Remove the screw.	
	 <p>(R12164)</p>	
10	Unfasten the 3 hooks on the top of the front grille.	
	 <p>Front grille</p> <p>(R12092)</p>	
11	Remove the front grille.	
	 <p>(R12093)</p>	

4. Removal of Front Panel Mechanism ASSY

Procedure



Warning

Be sure to wait for 10 minutes or more after turning off all power supplies before disassembling work.

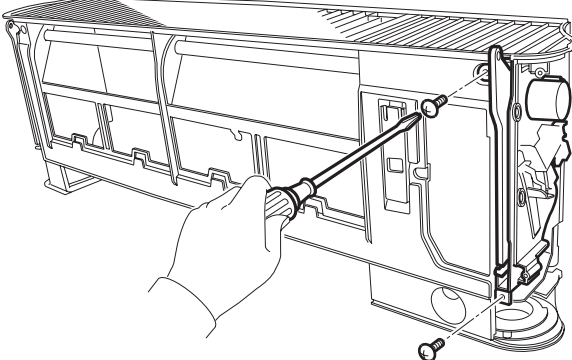
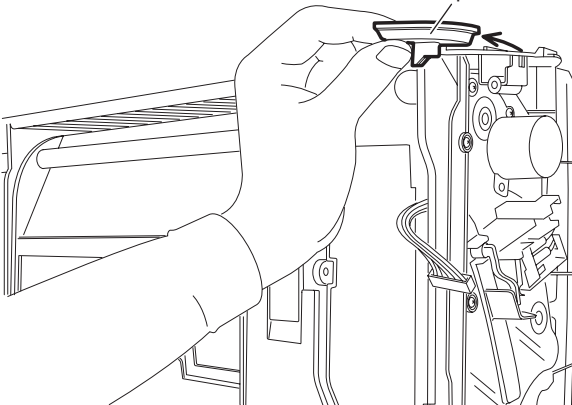
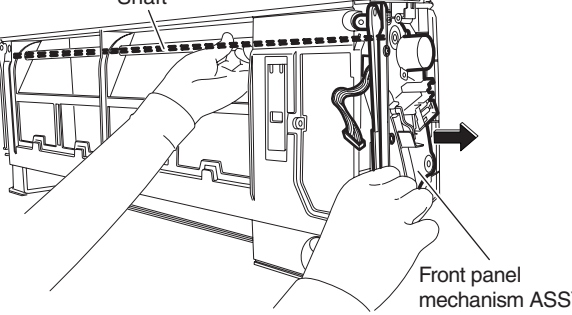
Step	Procedure	Procedure	Points
1	Remove the 2 screws of the front grille (right).	 <p>(R12094)</p>	
2	Remove the guide panel.	 <p>Guide panel</p> <p>(R12095)</p>	
3	Remove the front panel mechanism ASSY (right), holding the shaft.	 <p>Shaft</p> <p>Front panel mechanism ASSY</p> <p>(R12096)</p>	<ul style="list-style-type: none"> ■ Remove the front panel mechanism ASSY (left) in the same way.

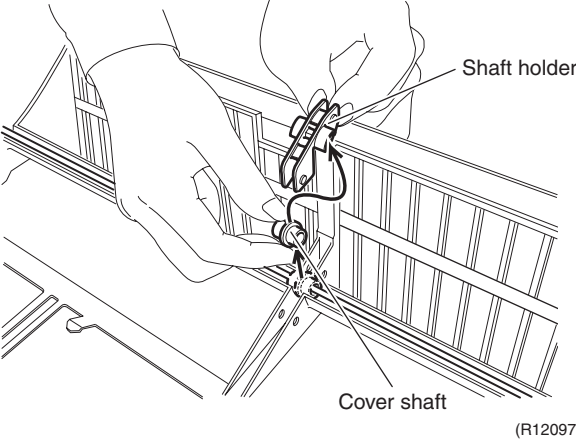
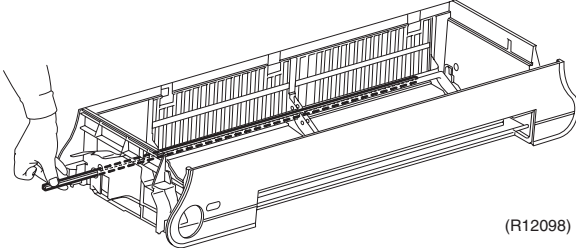
Step	Procedure	Points
4	Remove the shaft holder and the cover shaft.	
	 <p>(R12097)</p>	
5	Remove the shaft.	
	 <p>(R12098)</p>	

5. Removal of Display Lens ASSY

Procedure



Warning

Be sure to wait for 10 minutes or more after turning off all power supplies before disassembling work.

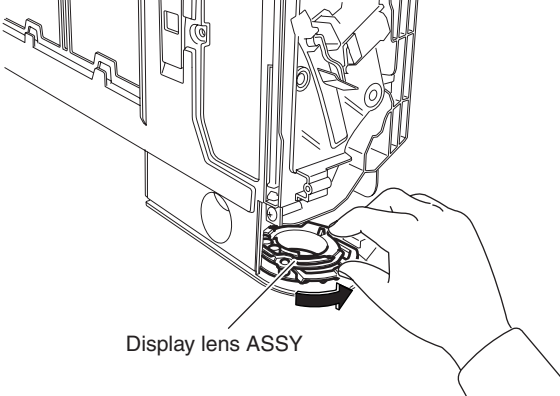
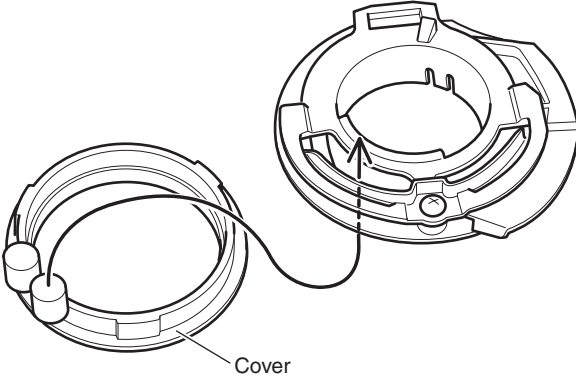
Step	Procedure	Procedure	Points
1	Remove the display lens ASSY by turning it counterclockwise.	 <p style="text-align: right;">(R12102)</p>	
2	Unfasten the hook and remove the cover.	 <p style="text-align: right;">(R12103)</p>	

6. Removal of Reduction Motor / Limit Switch

Procedure



Warning

Be sure to wait for 10 minutes or more after turning off all power supplies before disassembling work.

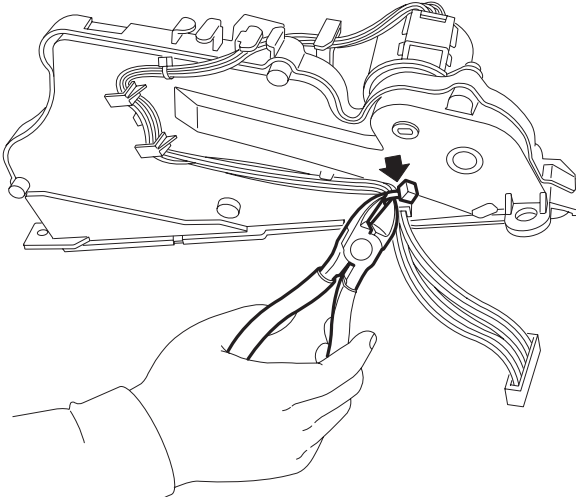
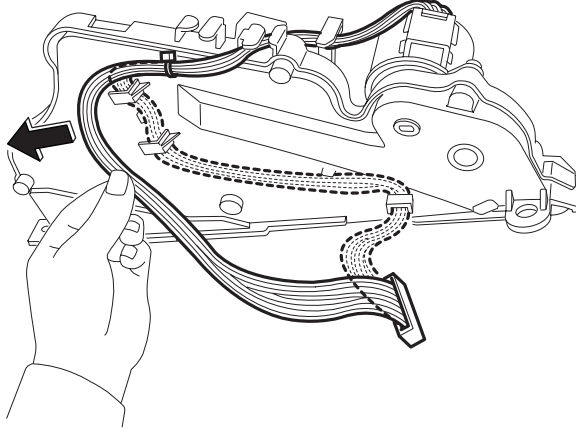
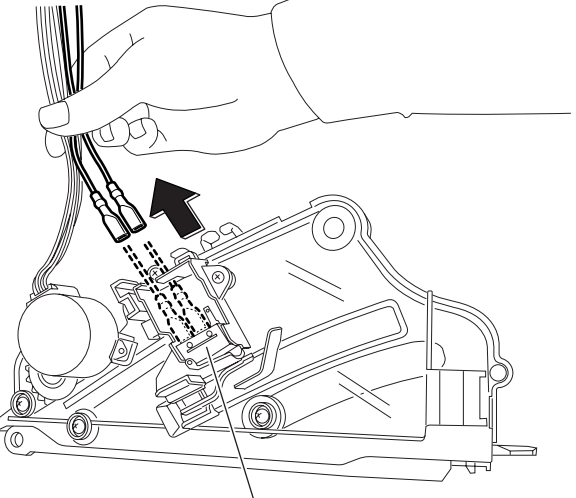
Step	Procedure	Points
1	Cut the clamp of the front panel mechanism ASSY (right).	
	 <p style="text-align: right;">(R12104)</p>	
2	Release the harness from the hooks.	
	 <p style="text-align: right;">(R12105)</p>	
3	Pull out the terminals of the limit switch.	
	 <p style="text-align: center;">Limit switch</p> <p style="text-align: right;">(R12106)</p>	

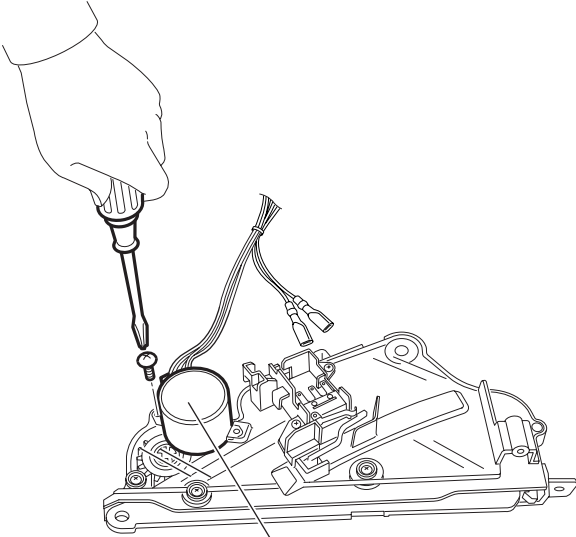
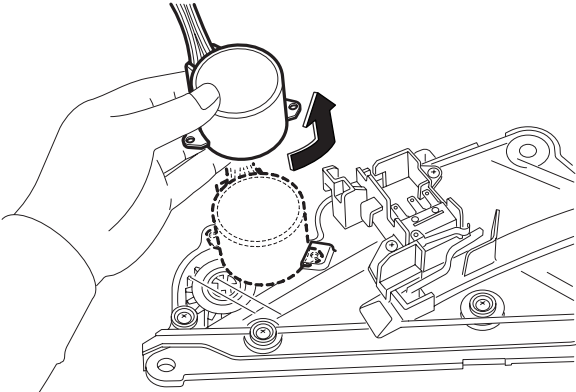
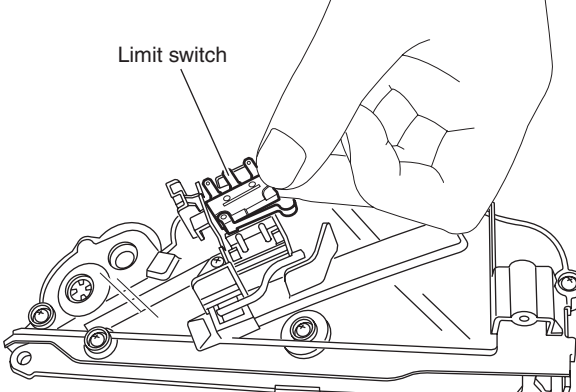
Step	Procedure	Points
4	Remove the screw of the reduction motor.	
	 <p style="text-align: center;">Reduction motor</p> <p style="text-align: right;">(R12107)</p>	
5	Remove the reduction motor by turning it counterclockwise.	
	 <p style="text-align: right;">(R12108)</p>	
6	Remove the limit switch.	
	 <p style="text-align: right;">(R12109)</p>	

7. Removal of Fan Guards / Electrical Box

Procedure



Warning

Be sure to wait for 10 minutes or more after turning off all power supplies before disassembling work.

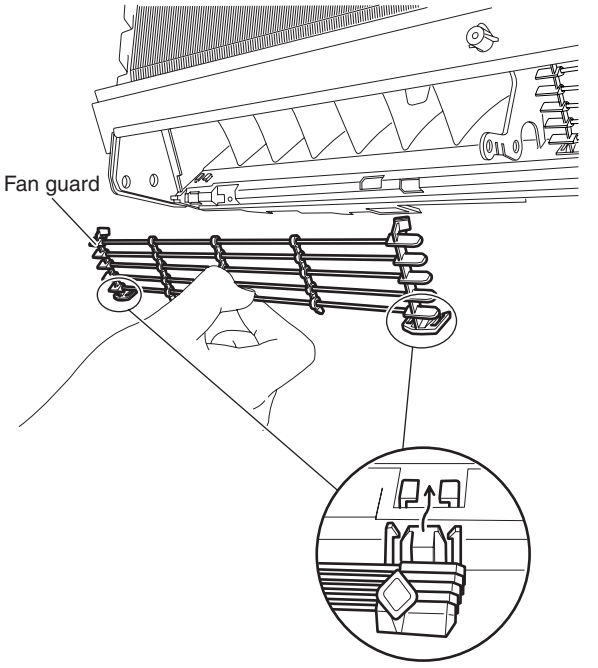
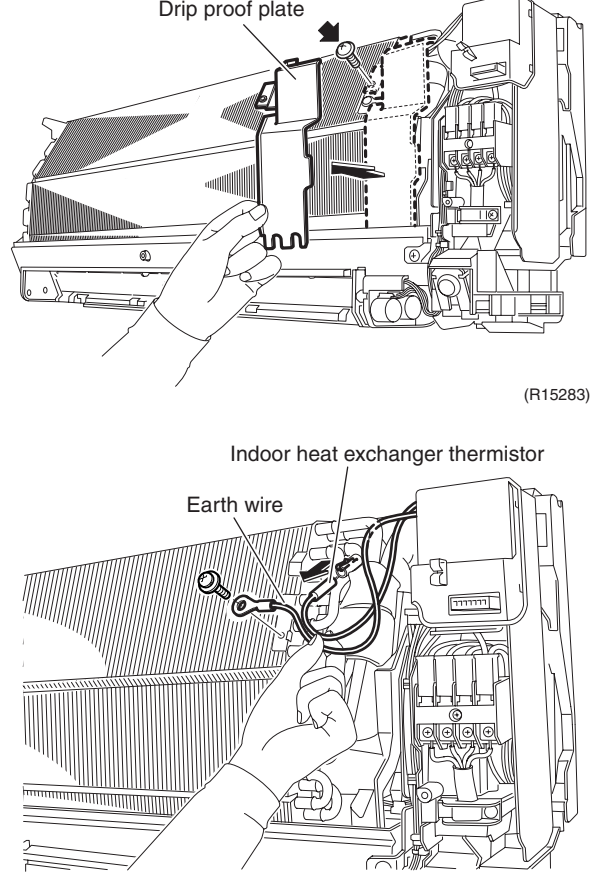
Step	Procedure	Points
<p>1. Remove the fan guards.</p> <p>1 Unfasten the 2 hooks and remove the fan guard.</p>	 <p>Fan guard</p> <p>(R12110)</p>	<ul style="list-style-type: none"> Use a sharp tool such as an awl to unfasten the lower hooks.
<p>2. Remove the electrical box.</p> <p>1 Remove the screw and remove the drip proof plate.</p> <p>2 Remove the screw and release the earth wire. Pull out the indoor heat exchanger thermistor.</p>	 <p>Drip proof plate</p> <p>Indoor heat exchanger thermistor</p> <p>Earth wire</p> <p>(R15283)</p> <p>(R12112)</p>	<p>Preparation</p> <ul style="list-style-type: none"> Remove the front grille according to the "Removal of Front Grille".

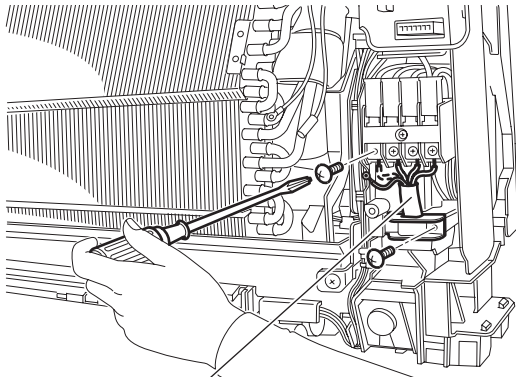
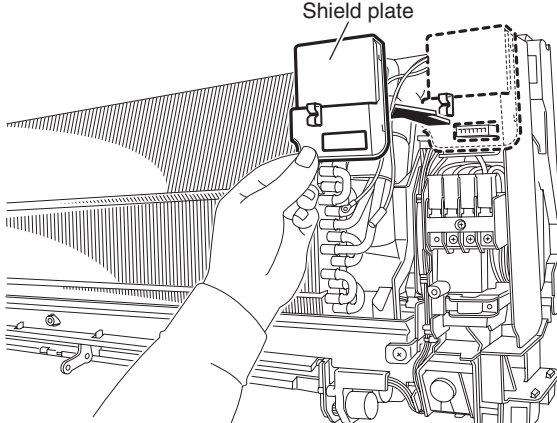
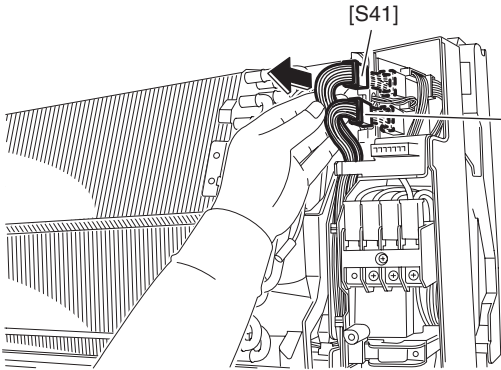
Step	Procedure	Points
3	<p>Remove the screws and release the connecting wires.</p>  <p style="text-align: center;">Connecting wire</p> <p style="text-align: right;">(R12113)</p>	
4	<p>Remove the shield plate.</p>  <p style="text-align: center;">Shield plate</p> <p style="text-align: right;">(R12114)</p>	
5	<p>Disconnect the connectors for the swing motors [S41] and for the fan motor [S200].</p>  <p style="text-align: center;">[S41]</p> <p style="text-align: right;">[S200]</p> <p style="text-align: right;">(R12115)</p>	

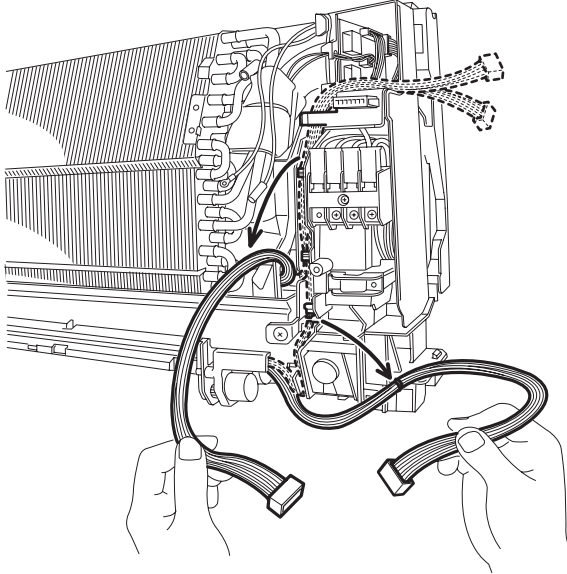
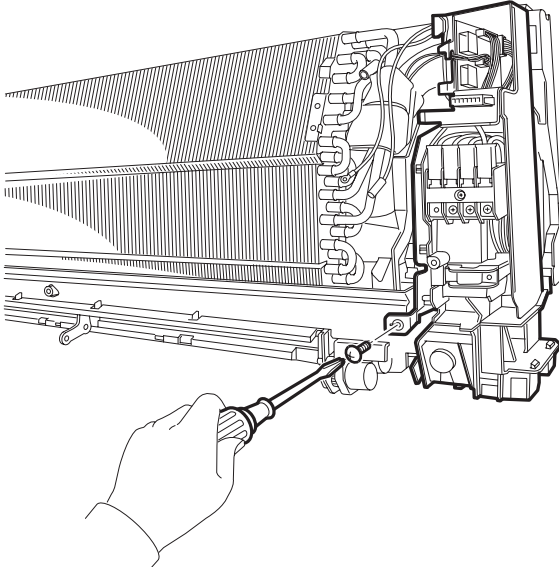
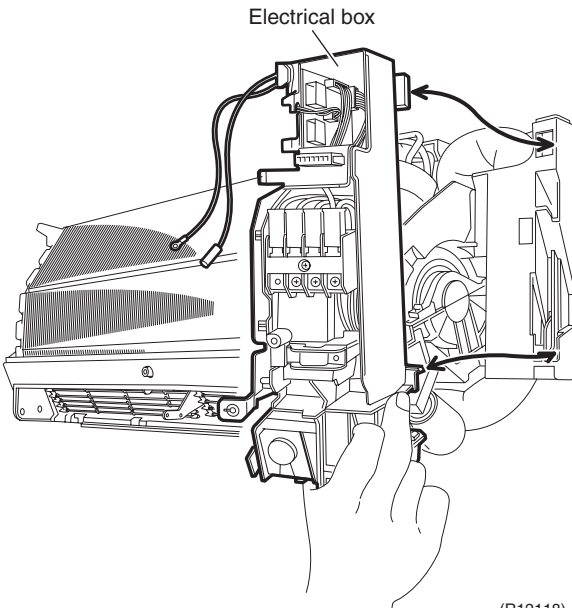
Step	Procedure	Points
6	Release the harnesses.	
	 <p style="text-align: right;">(R12116)</p>	
7	Remove the screw.	
	 <p style="text-align: right;">(R12117)</p>	
8	Unfasten the 2 hooks and remove the electrical box.	<ul style="list-style-type: none"> ■ There are 2 hooks on the bottom frame. When reassembling, fit the rear side of the electrical box to the hooks.
	 <p style="text-align: right;">(R12118)</p>	

8. Removal of PCBs

Procedure



Warning

Be sure to wait for 10 minutes or more after turning off all power supplies before disassembling work.

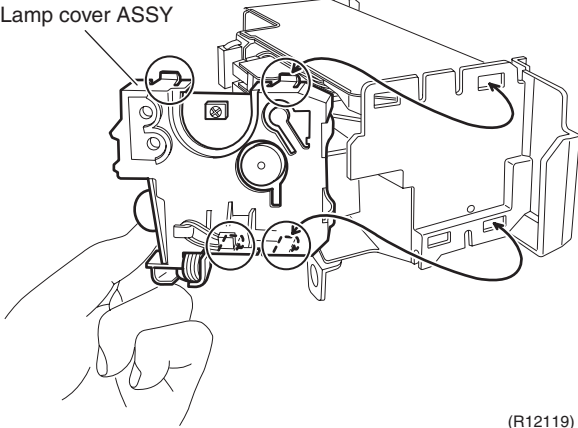
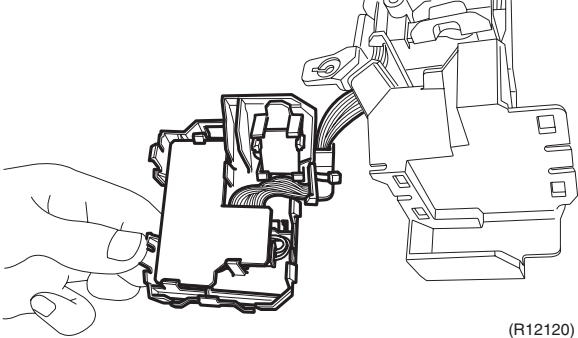
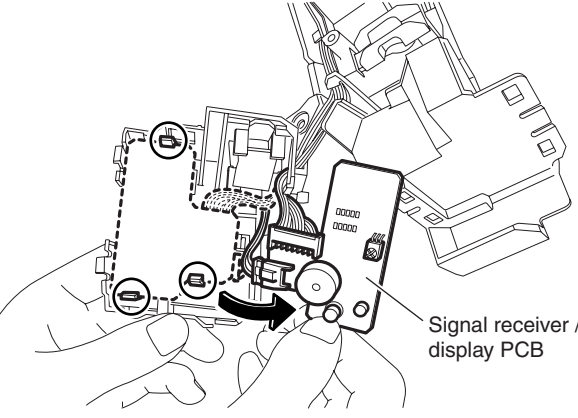
Step	Procedure	Points
1	<p>Unfasten the 4 hooks and remove the lamp cover ASSY from the electrical box.</p>  <p style="text-align: right;">(R12119)</p>	
2	<p>Turn over the lamp cover ASSY.</p>  <p style="text-align: right;">(R12120)</p>	
3	<p>Unfasten the 3 hooks and remove the signal receiver / display PCB.</p>  <p style="text-align: right;">(R12121)</p>	

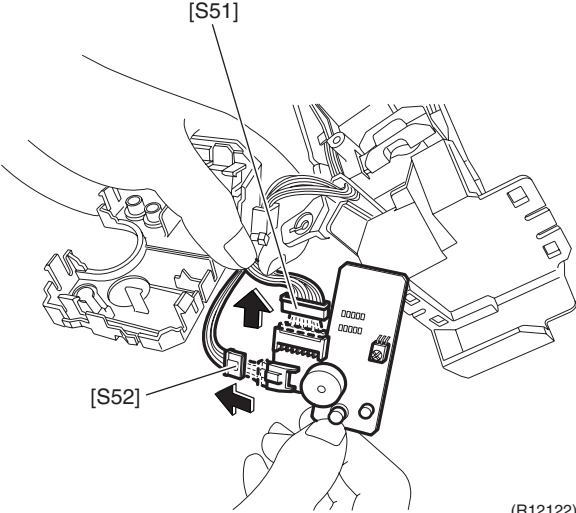
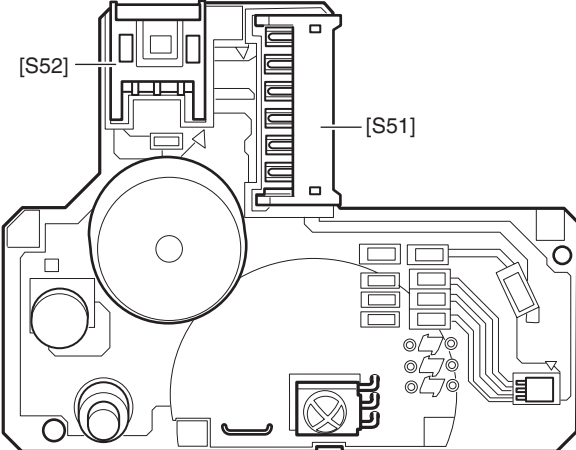
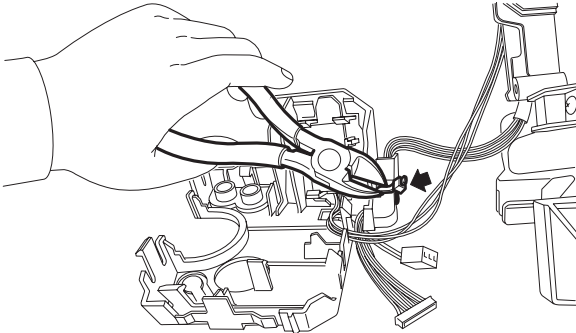
Step	Procedure	Points
<p>4</p>	<p>Disconnect the connectors for the control PCB [S51] and for the room temperature thermistor [S52].</p>  <p>(R12122)</p>  <p>(R12123)</p>	<p>[S51]: control PCB [S52]: room temperature thermistor</p>
<p>5</p>	<p>Cut the clamp.</p>  <p>(R12124)</p>	

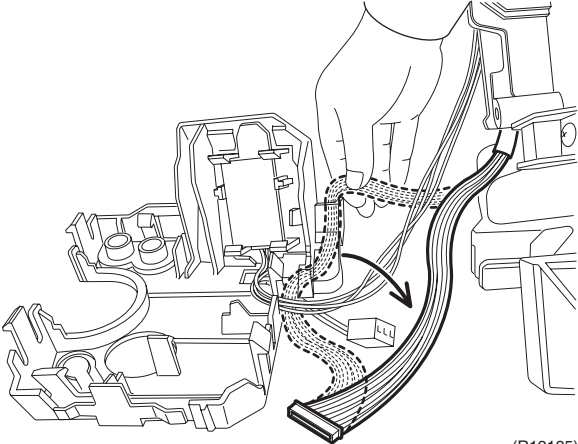
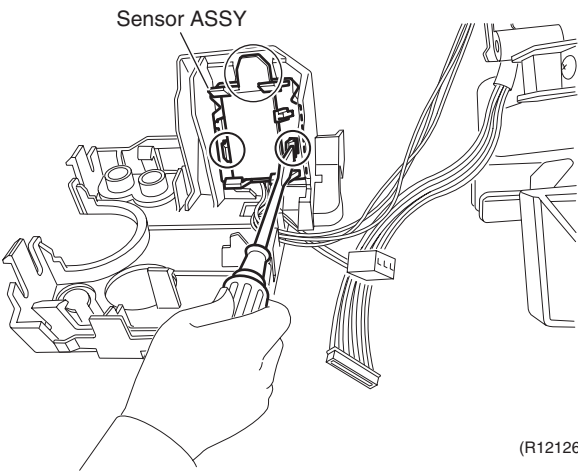
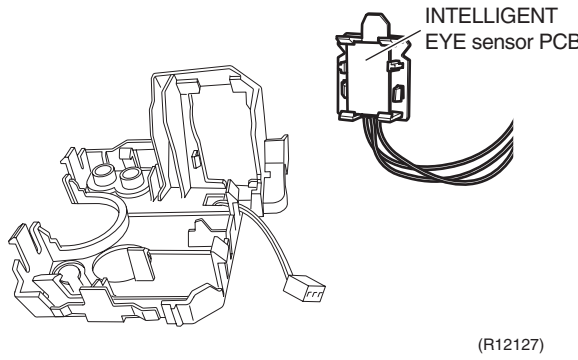
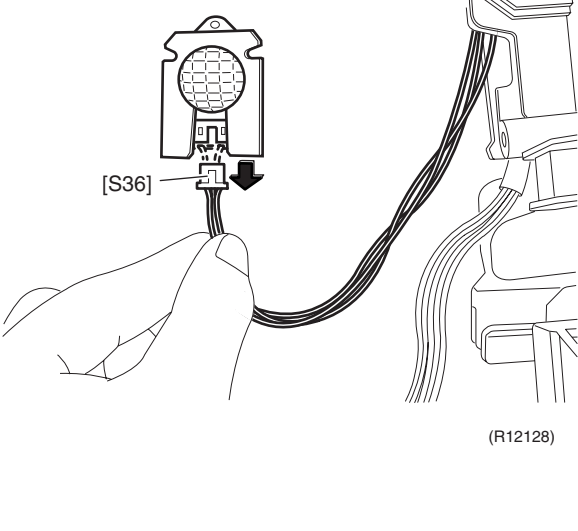
Step	Procedure	Procedure	Points
6	Release the harness from the hook.	 <p>(R12125)</p>	
7	Unfasten the 3 hooks of the sensor ASSY with a flat screwdriver.	 <p>Sensor ASSY</p> <p>(R12126)</p>	
8	Remove the sensor ASSY.	 <p>INTELLIGENT EYE sensor PCB</p> <p>(R12127)</p>	
9	Disconnect the connector [S36] from the INTELLIGENT EYE sensor PCB.	 <p>[S36]</p> <p>(R12128)</p>	

Step	Procedure	Points
10	Cut the clamp.	
11	Remove the shield plate.	
12	Remove the screw of the terminal board.	

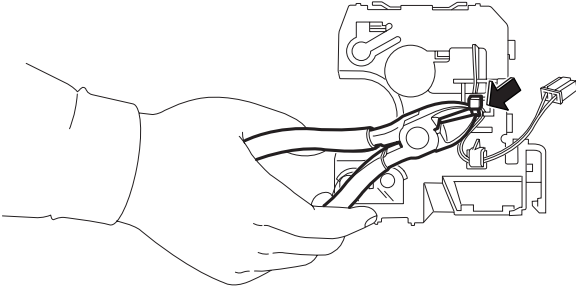

(R12129)

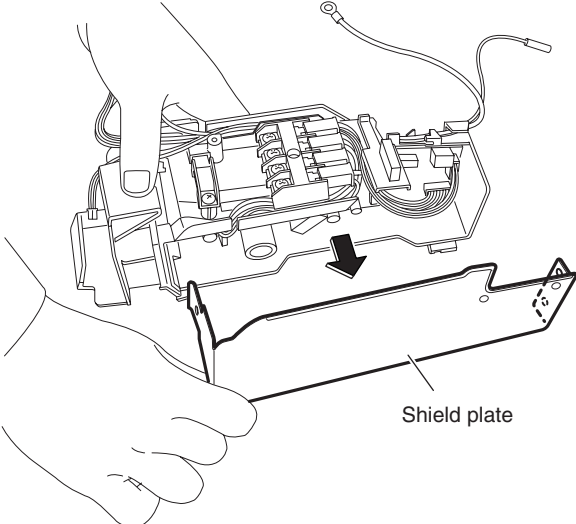

(R12130)

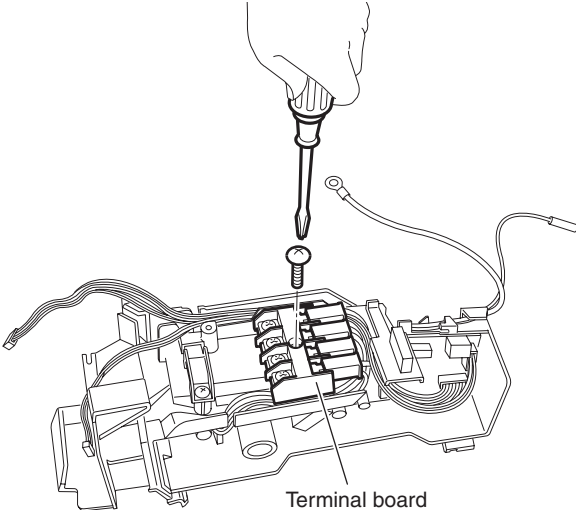

(R12131)

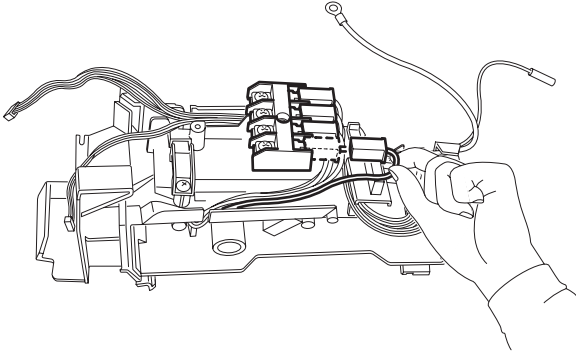
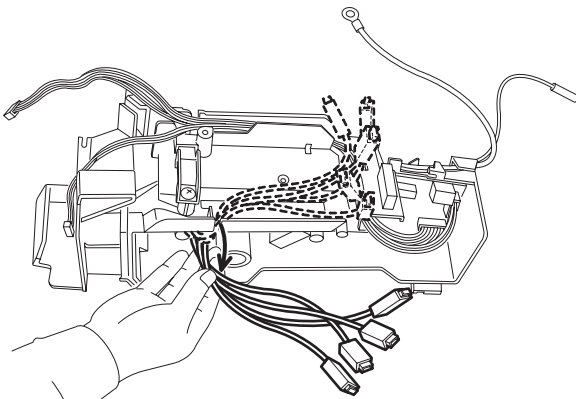
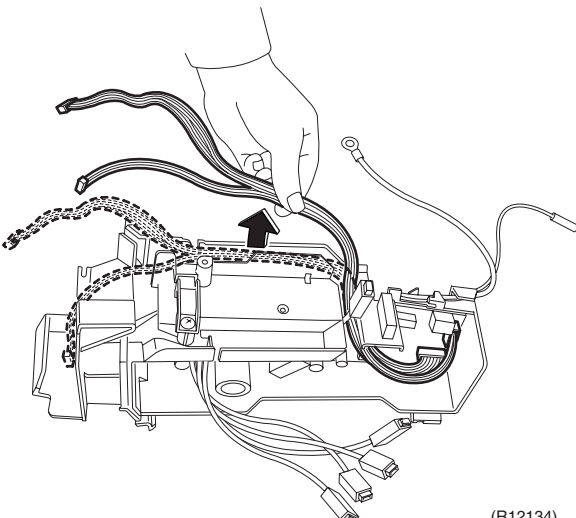
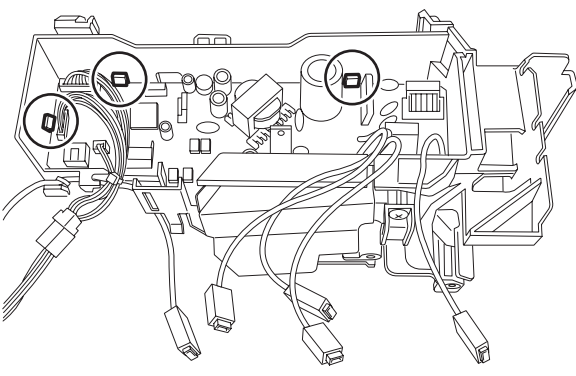
Step	Procedure	Procedure	Points
13	Pull out the terminals and remove the terminal board.	 <p data-bbox="1007 607 1075 629">(R12132)</p>	
14	Release the harnesses from the groove.	 <p data-bbox="1007 1115 1075 1137">(R12133)</p>	
15	Release the harnesses of the signal receiver / display PCB.	 <p data-bbox="983 1664 1053 1686">(R12134)</p>	
16	Unfasten the 3 hooks.	 <p data-bbox="983 2101 1053 2123">(R12135)</p>	

Step	Procedure	Points
<p>17</p>	<p>Unfasten the other 2 hooks and remove the control PCB.</p> <p>(R12136)</p> <p>(R12137)</p>	<p>[S21]: HA connector [S25]: INTELLIGENT EYE sensor PCB [S32]: indoor heat exchanger thermistor [S41]: swing motors [S42]: reduction motor / limit switch [S46]: signal receiver / display PCB [S200]: fan motor</p>

9. Removal of Swing Motors

Procedure



Warning

Be sure to wait for 10 minutes or more after turning off all power supplies before disassembling work.

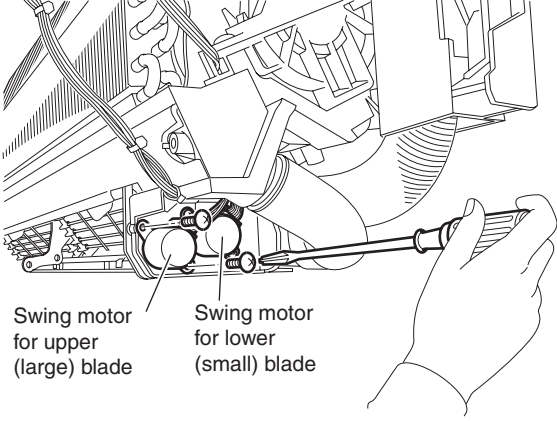
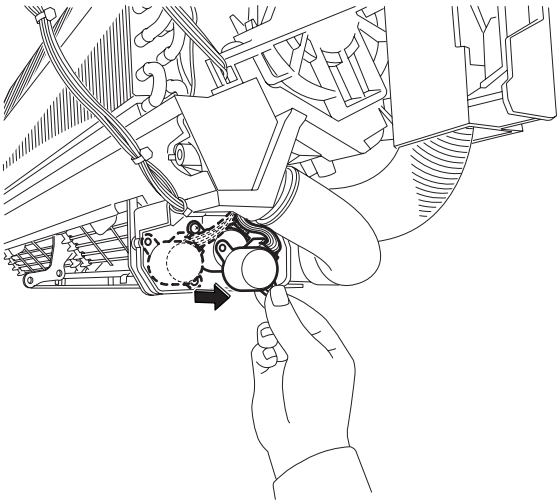
Step	Procedure	Procedure	Points
1	Remove the 2 screws of the swing motor.	 <p>Swing motor for upper (large) blade</p> <p>Swing motor for lower (small) blade</p> <p>(R12138)</p>	<ul style="list-style-type: none"> ■ Connector color Upper blade: white Lower blade: red
2	Remove the swing motor.	 <p>(R12139)</p>	<ul style="list-style-type: none"> ■ Remove the other swing motor in the same way.

10. Removal of Indoor Heat Exchanger

Procedure



Warning

Be sure to wait for 10 minutes or more after turning off all power supplies before disassembling work.

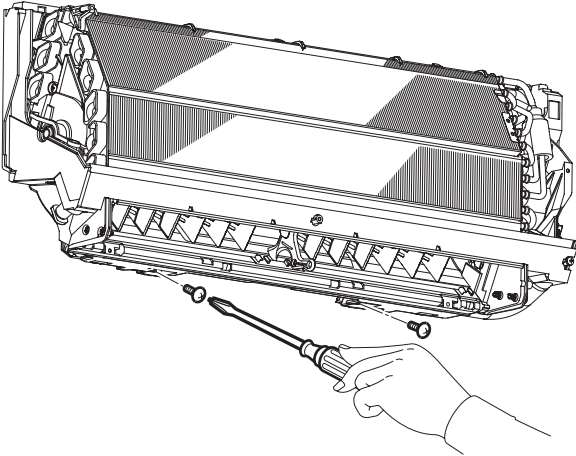
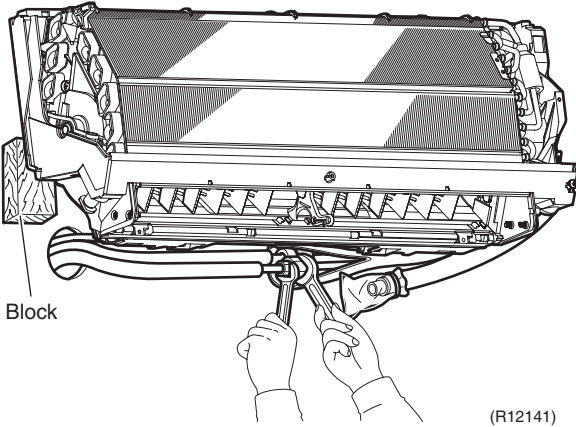
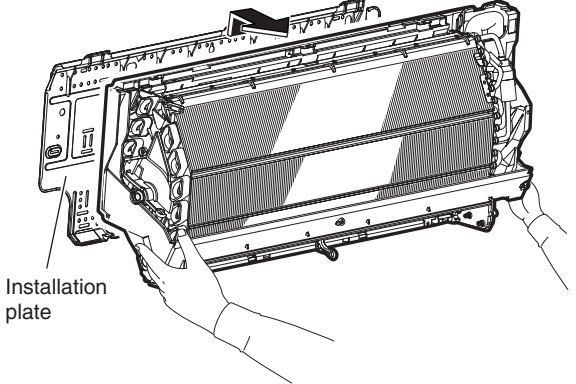
Step	Procedure	Points
<p>1. Disconnect the refrigerant piping.</p> <p>1 Remove the screws fixed to the installation plate.</p> <p>2 Hold the indoor unit up with a block. Disconnect the pipings with 2 wrenches.</p>	 <p style="text-align: right;">(R12140)</p>  <p>Block</p> <p style="text-align: right;">(R12141)</p>	<p>Caution</p> <p>In pump-down work, be sure to stop the compressor before disconnecting the refrigerant pipe. If the refrigerant pipe is disconnected with the compressor operating and the stop valve open, air may be sucked in to generate an over-pressure in refrigeration cycle, thus resulting in pipe rupture or accidental injury.</p> <ul style="list-style-type: none"> ■ Place a plastic sheet under the drain pan to prevent from wetting the floor with remaining drain. ■ If the drain hose is embedded in the wall, disconnect the drain hose beforehand. ■ When the pipings are disconnected, protect the both openings of pipe side and unit side from entering of moisture.
<p>2. Remove the indoor unit.</p> <p>1 Detach the indoor unit from the installation plate.</p>	 <p>Installation plate</p> <p style="text-align: right;">(R12142)</p>	

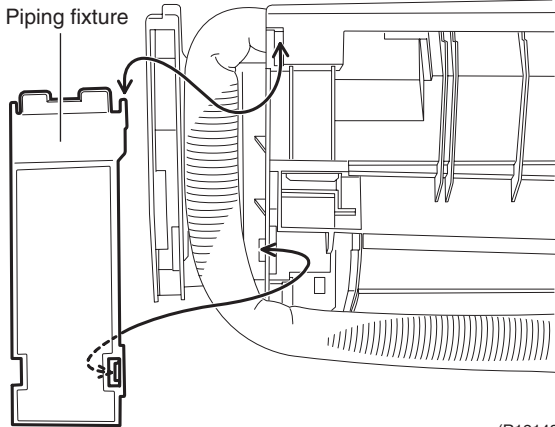
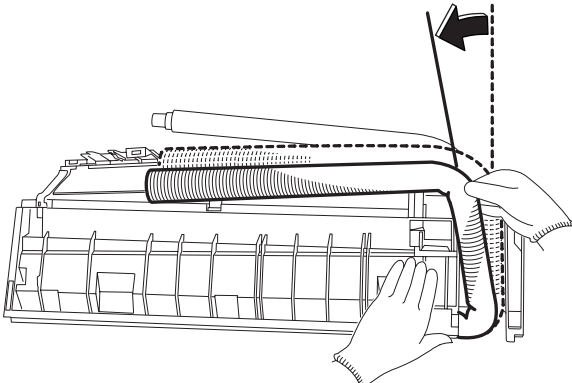
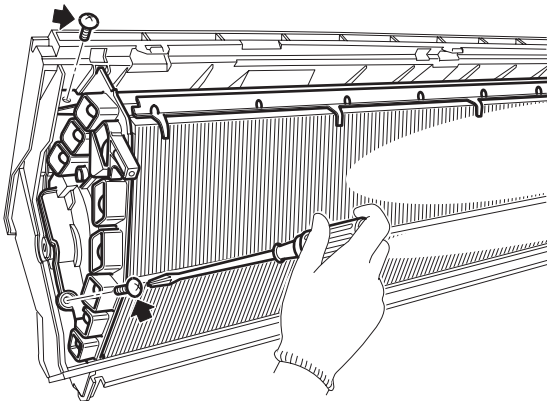
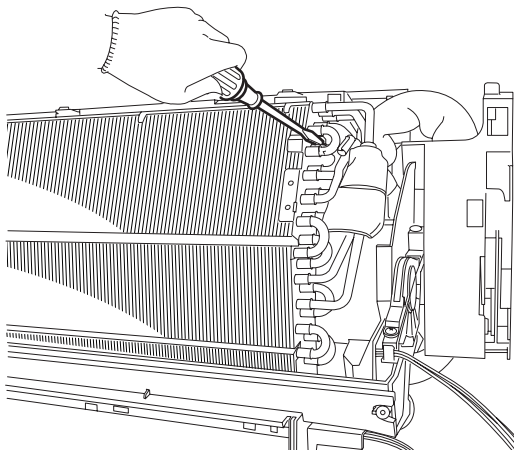
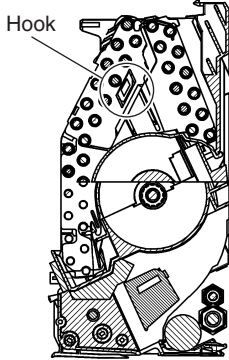
Step	Procedure	Points
3.	Remove the indoor heat exchanger.	
1	<p>Unfasten the hook of the piping fixture at the back of the indoor unit and pull out the pipe.</p>  <p style="text-align: right;">(R12143)</p>	
2	<p>Slightly widen the auxiliary pipe.</p>  <p style="text-align: right;">(R12144)</p>	<p>⚠ Caution When dismantling or mounting the indoor heat exchanger, be sure to wear gloves or wrap it with cloth before proceeding to the work. (You may be injured by the fins.)</p>
3	<p>Remove the 2 screws on the left side of the unit.</p>  <p style="text-align: right;">(R12145)</p>	
4	<p>Unfasten the hook on the right side of the unit with a flat screwdriver.</p>  <p style="text-align: right;">(R12146)</p>	<p>■ When reassembling, engage the hook.</p>  <p style="text-align: right;">(R12159)</p>

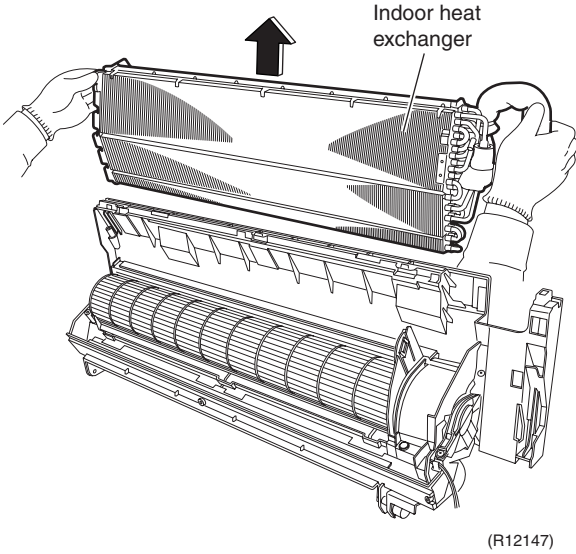
Step	Procedure	Points
5	<p data-bbox="201 215 472 277">Remove the indoor heat exchanger.</p>  <p data-bbox="978 770 1050 792">(R12147)</p>	

11. Removal of Fan Rotor / Fan Motor

Procedure



Warning

Be sure to wait for 10 minutes or more after turning off all power supplies before disassembling work.

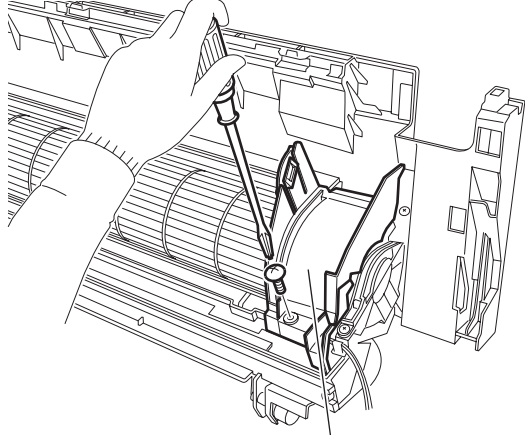
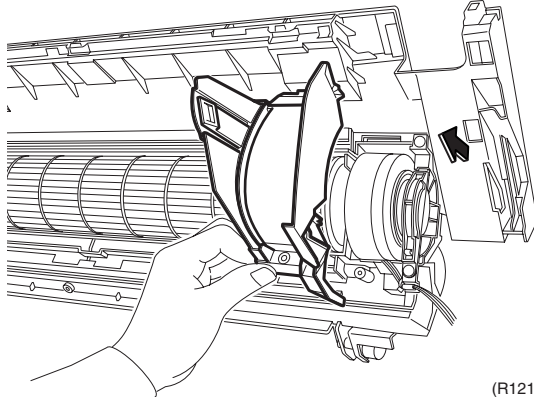
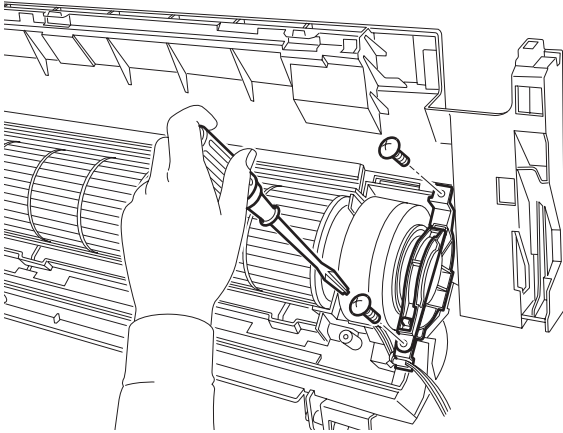
Step	Procedure	Points
1. Remove the right side panel. 1 Remove the screw. 2 Remove the right side panel.	 <p style="text-align: center;">Right side panel (R12148)</p>  <p style="text-align: right;">(R12149)</p>	<ul style="list-style-type: none"> ■ You can remove the fan rotor without detaching the right side panel.
2. Remove the fan rotor. 1 Remove the 2 screws.	 <p style="text-align: right;">(R12150)</p>	

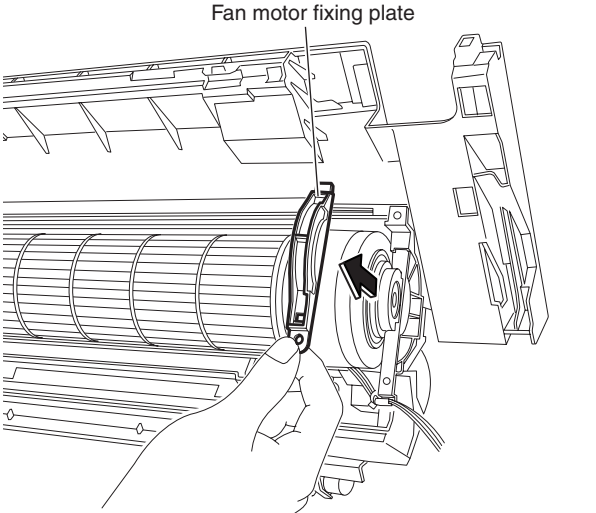
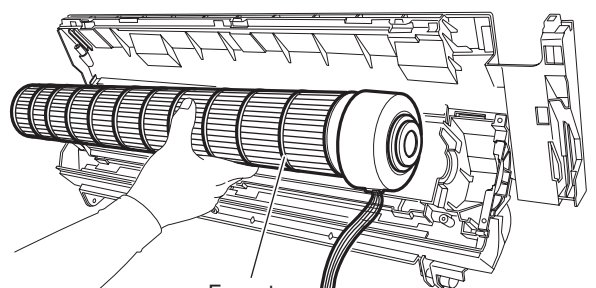
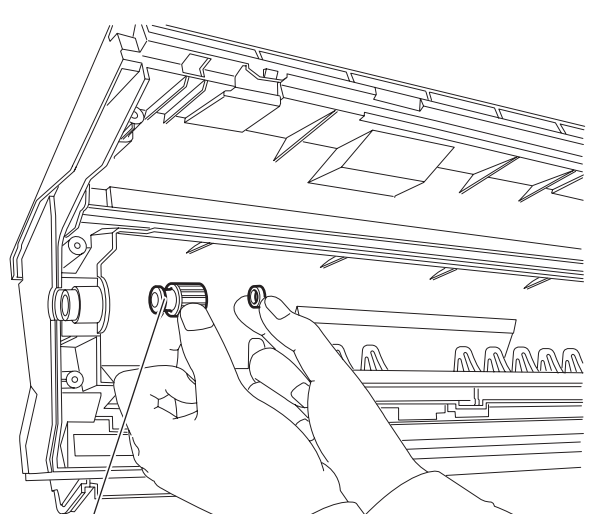
Step		Procedure	Points
2	Remove the fan motor fixing plate.	 <p>Fan motor fixing plate</p> <p>(R12151)</p>	
3	Remove the fan rotor.	 <p>Fan rotor</p> <p>(R12152)</p>	
4	Remove the bearing.	 <p>Bearing</p> <p>(R12153)</p>	

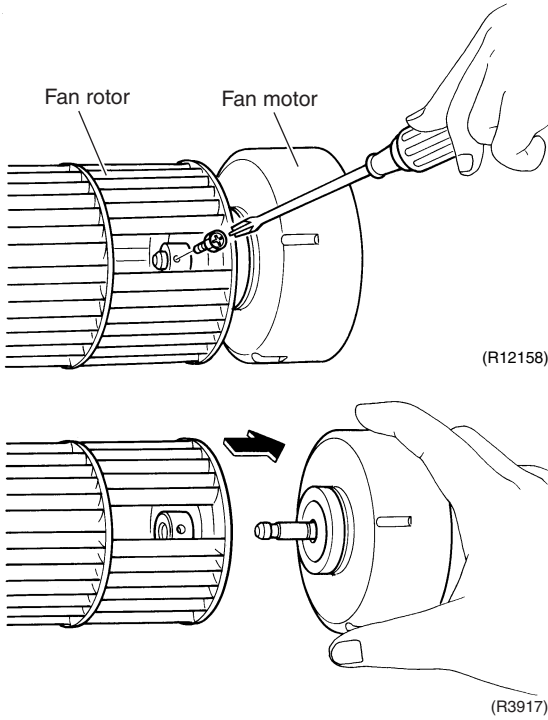
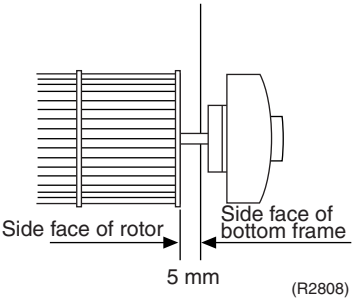
Step	Procedure	Points
<p>3. Remove the fan motor.</p> <p>1</p>	<p>Remove the screw and remove the fan motor.</p> 	<ul style="list-style-type: none"> When reassembling the fan motor and the fan rotor, provide as much as 5 mm of play between the side face of the rotor and the bottom frame. 

12. Removal of Vertical Blade ASSYs

Procedure



Warning

Be sure to wait for 10 minutes or more after turning off all power supplies before disassembling work.

Step	Procedure	Points
1	Unfasten the 3 hooks at the shaft mounting part by pressing them with a flat screwdriver.	<ul style="list-style-type: none"> ■ A vertical blade ASSY has 6 fins. It is impossible to replace only one fin. ■ The vertical blade ASSY is not marked for difference between right and left.
2	Unfasten the hooks at the upper 2 positions with a flat screwdriver.	
3	Remove the vertical blade ASSY.	

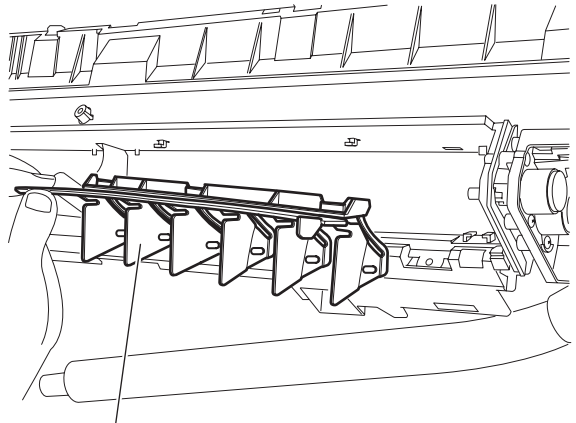
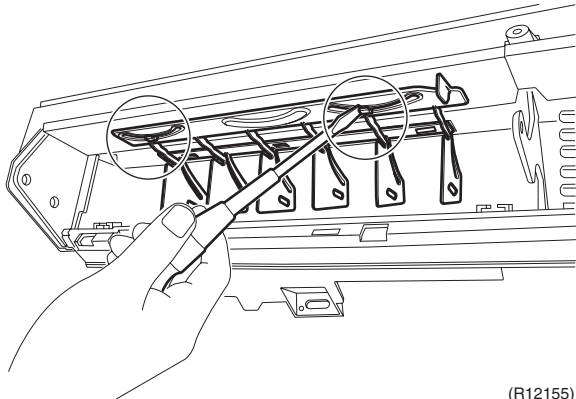
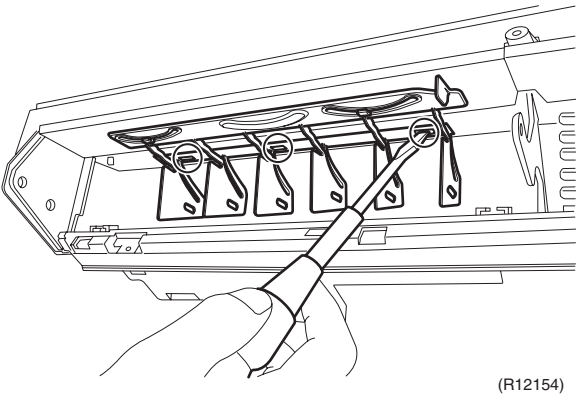

Revision History

Month / Year	Version	Revised contents
01 / 2013	Si041058	First edition

Warning



- Daikin products are manufactured for export to numerous countries throughout the world. Prior to purchase, please confirm with your local authorised importer, distributor and/or retailer whether this product conforms to the applicable standards, and is suitable for use, in the region where the product will be used. This statement does not purport to exclude, restrict or modify the application of any local legislation.
- Ask a qualified installer or contractor to install this product. Do not try to install the product yourself. Improper installation can result in water or refrigerant leakage, electrical shock, fire or explosion.
- Use only those parts and accessories supplied or specified by Daikin. Ask a qualified installer or contractor to install those parts and accessories. Use of unauthorised parts and accessories or improper installation of parts and accessories can result in water or refrigerant leakage, electrical shock, fire or explosion.
- Read the User's Manual carefully before using this product. The User's Manual provides important safety instructions and warnings. Be sure to follow these instructions and warnings.

If you have any enquiries, please contact your local importer, distributor and/or retailer.

Cautions on product corrosion

1. Air conditioners should not be installed in areas where corrosive gases, such as acid gas or alkaline gas, are produced.
2. If the outdoor unit is to be installed close to the sea shore, direct exposure to the sea breeze should be avoided. If you need to install the outdoor unit close to the sea shore, contact your local distributor.

Dealer

DAIKIN INDUSTRIES, LTD.

Head Office:
Umeda Center Bldg., 2-4-12, Nakazaki-Nishi,
Kita-ku, Osaka, 530-8323 Japan

Tokyo Office:
JR Shinagawa East Bldg., 2-18-1, Konan,
Minato-ku, Tokyo, 108-0075 Japan

http://www.daikin.com/global_ac/

©All rights reserved