



REMOVAL PROCEDURE



S E R V I C E M A N U A L

4.0/5.0/6.0/7.1 kW Class

-  Indoor Unit
-  Inverter
-  Wall Mounted Type



Service Manual Removal Procedure

Indoor Unit

●Cooling Only

FTKS40JVLT

FTKS50KVMA

FTKS60KVMA

FTKS71KVMA

FTXS60GV1B

FTXS71GV1B

●Heat Pump

FTXS40JVLT

FTXS50KVMA

FTXS60KVMA

FTXS71KVMA

FTXS60GV1B

FTXS71GV1B

Table of Contents

1. Removal of Air Filters / Front Panel	2
2. Removal of Front Grille	5
3. Removal of Horizontal Blades / Vertical Blades.....	6
4. Removal of Electrical Box / PCBs / Swing Motors	8
5. Removal of Indoor Heat Exchanger	15
6. Removal of Fan Motor / Fan Rotor.....	18



Note: ♦ The illustrations may be slightly different depending on the model.

1. Removal of Air Filters / Front Panel

Procedure



Warning

Be sure to wait for 10 minutes or more after turning off all power supplies before disassembling work.

Step	Procedure	Points
<p>1. Appearance features</p>		<p>Warning Dangerous: High voltage A high voltage is applied to all the electric circuits of this product including thermistors.</p> <ul style="list-style-type: none"> ■ When the signal receiver catches a signal from the remote controller, the receiving tone sounds and the operation lamp blinks immediately to confirm the signal reception. ■ When the [ON/OFF] button is kept pressed for 5 seconds, the forced cooling operation is performed for about 15 minutes.
<p>2. Remove the air filters.</p> <p>1 Open the front panel to the position where it stops.</p> <p>2 Slightly push up the center knob of the air filter and unfasten the hooks.</p> <p>3 Pull out the air filter downward and remove it.</p>		<ul style="list-style-type: none"> ■ The air filter is not marked for difference between the right and left sides. ■ Insert the air filter with the "FRONT" mark faced up. ■ The air filter can be set easily by inserting it along the guides. ■ Be sure to insert the hooks (at 2 lower positions) when reassembling the air filter.

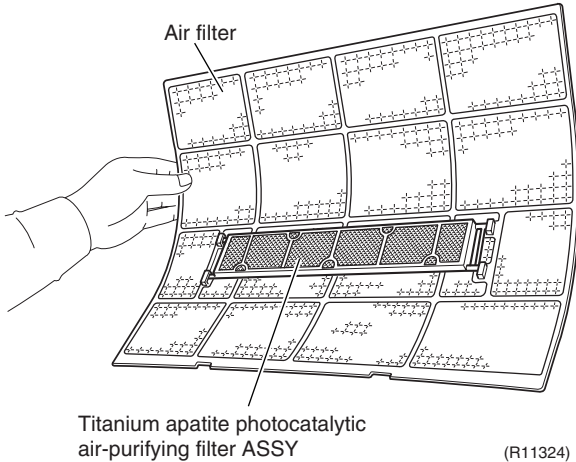
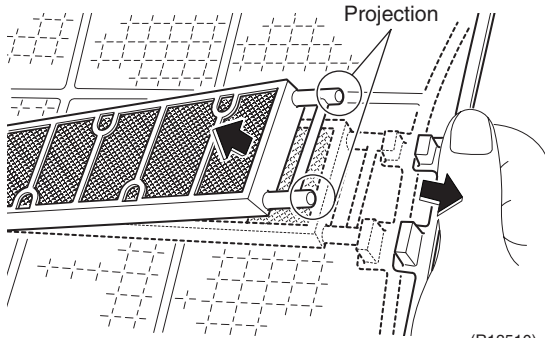
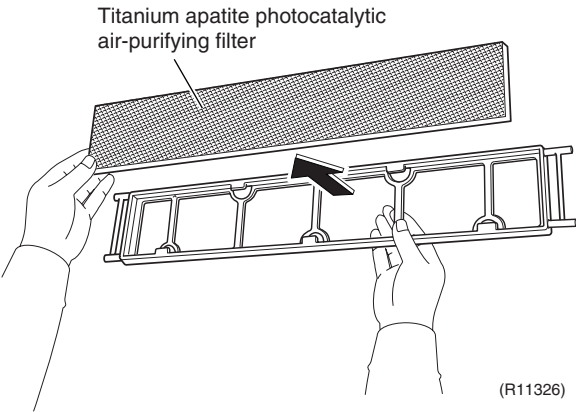
Step	Procedure	Points	
3.	Remove the Titanium apatite photocatalytic air-purifying filters.		
1	<p>The Titanium apatite photocatalytic air-purifying filter ASSY is attached to the back of the air filter.</p>  <p style="text-align: right;">(R11324)</p>	<p>■ The right and left filters are interchangeable.</p>	
2	<p>Remove the Titanium apatite photocatalytic air-purifying filter ASSY by bending the air filter and releasing the projections from the air filter frame.</p>  <p style="text-align: right;">(R13510)</p>		
3	<p>Unfasten the 5 hooks and remove the Titanium apatite photocatalytic air-purifying filter from its frame.</p>  <p style="text-align: right;">(R11326)</p>		

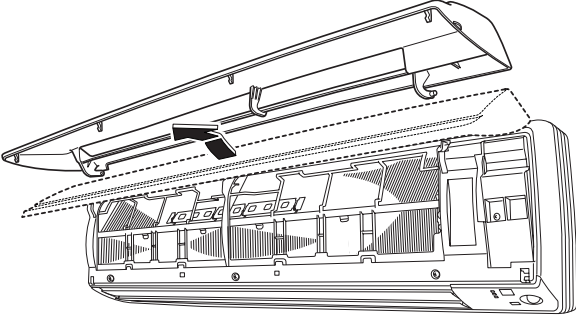
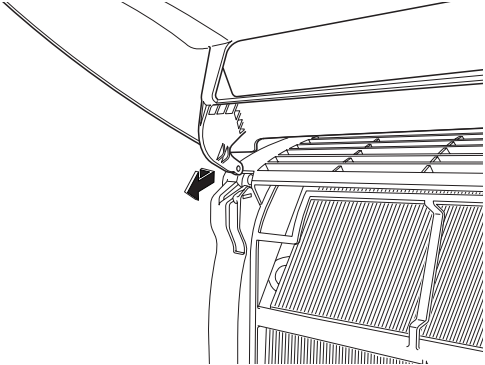
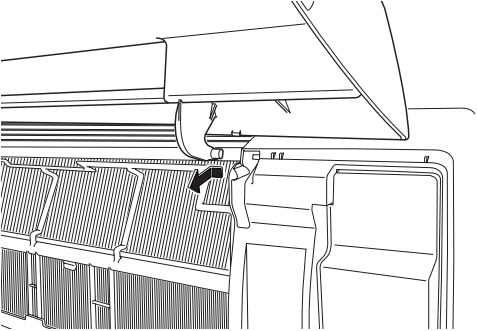
Step	Procedure	Points
<p>4. Remove the front panel.</p> <p>1</p>	<p>While opening the front panel further than it stops, release both the shafts and remove the front panel.</p>  <p>(R11327)</p>  <p>(R11328)</p>  <p>(R11329)</p>	<ul style="list-style-type: none"> ■ Slide the front panel from side to side to release each shaft. ■ Align the right and left shafts with grooves in turn and insert them to the end when reassembling.

2. Removal of Front Grille

Procedure



Warning Be sure to wait for 10 minutes or more after turning off all power supplies before disassembling work.

Step	Procedure	Points
1	Remove the 3 screws of the front grille.	<ul style="list-style-type: none"> Refer to the removal procedure in a reverse way when reassembling.
2	Unfasten the 3 hooks on the top of the front grille.	<ul style="list-style-type: none"> The convex marks (...) on the front panel indicate the position of the hooks.
3	Pull the upper part of the front grille out and lift the lower part up, and then remove the front grille.	<ul style="list-style-type: none"> When reassembling, make sure that all the 3 hooks are fastened as they were.

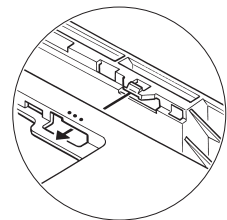
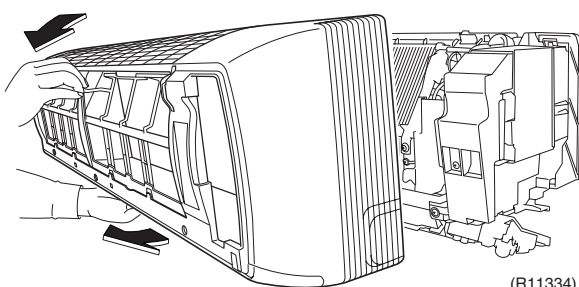
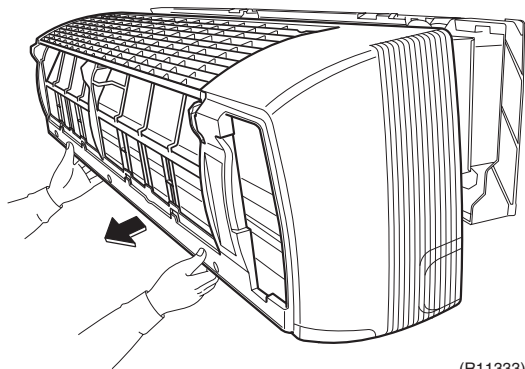
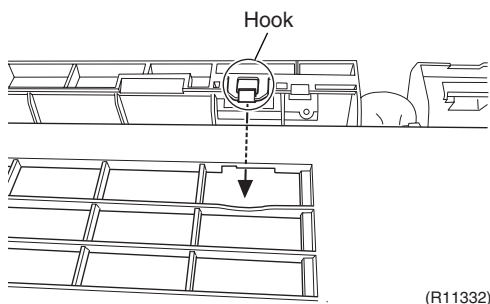
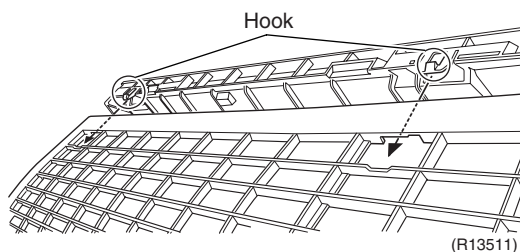
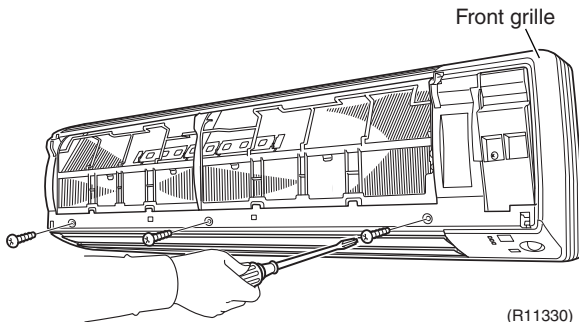

3. Removal of Horizontal Blades / Vertical Blades

Procedure



Warning Be sure to wait for 10 minutes or more after turning off all power supplies before disassembling work.

Step	Procedure	Points
1. Remove the horizontal blades.		
1 Open the horizontal blades.		
2 Release the left shaft of the horizontal blade (large).		
3 Release the right shaft.		<p>■ Installation procedure</p> <ol style="list-style-type: none"> 1. Since the key pattern hook is provided, rotate the blade and fit it to the right shaft first. 2. Fit the blade to the center and left shafts.
4 Release the center shaft. Remove the horizontal blade (large).		
5 Remove the horizontal blade (small) in the same way.		

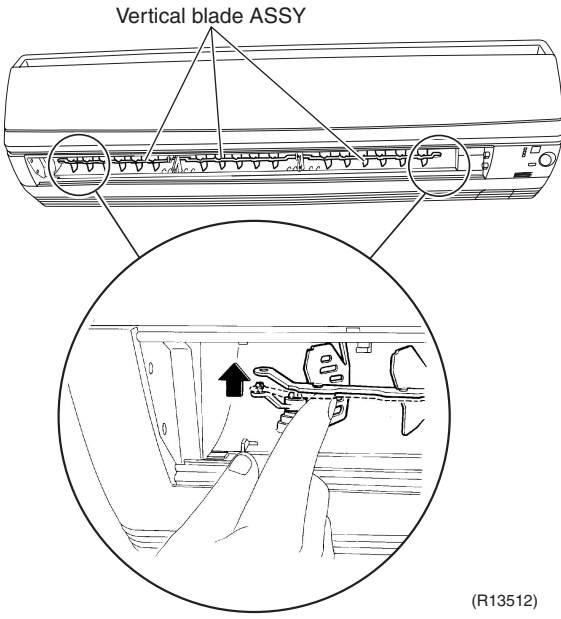
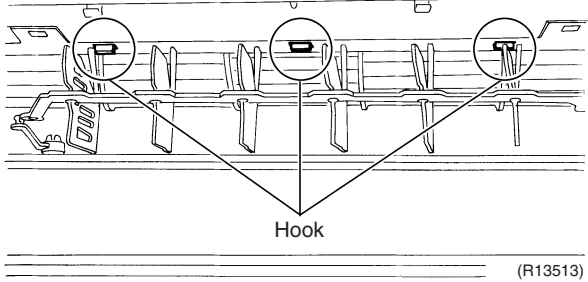
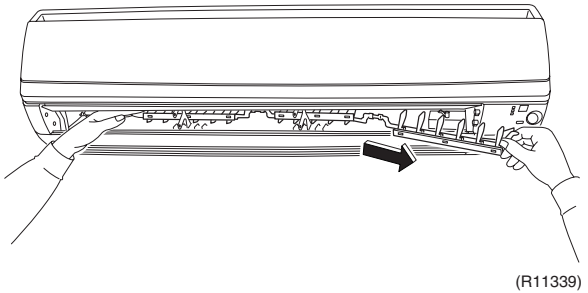
Step	Procedure	Points
2.	Remove the vertical blade ASSYs.	<ul style="list-style-type: none"> ■ The unit has 3 vertical blade ASSYs linked to one another with the interlock rods.
1	<p>Release the right and left shafts.</p>  <p style="text-align: center;">Vertical blade ASSY</p> <p style="text-align: right;">(R13512)</p>	
2	<p>Unfasten the 3 hooks for each vertical blade ASSY.</p>  <p style="text-align: center;">Hook</p> <p style="text-align: right;">(R13513)</p>	
3	<p>Pull the vertical blade ASSYs rightward and remove them.</p>  <p style="text-align: right;">(R11339)</p>	

4. Removal of Electrical Box / PCBs / Swing Motors

Procedure



Warning Be sure to wait for 10 minutes or more after turning off all power supplies before disassembling work.

Step	Procedure	Points
1. Remove the electrical box.	<p>Service cover (R13574)</p> <p>(R13575)</p>	
2 Remove the screw and remove the drip proof plate.	<p>Drip proof plate</p> <p>(R11343)</p>	
3 Pull out the indoor heat exchanger thermistor.	<p>Indoor heat exchanger thermistor</p> <p>(R17633)</p>	<p>■ Be careful not to lose the clip of the thermistor.</p>
4 Remove the screw of the earth wire.	<p>Earth wire</p> <p>(R17633)</p>	<p>Clip</p> <p>(R11268)</p>
5 Remove the 4 screws of the connection wires.	<p>Connection wire</p> <p>Wire retainer</p> <p>(R17633)</p>	
6 Remove the screw of the wire retainer.	<p>Wire retainer</p> <p>(R17633)</p>	

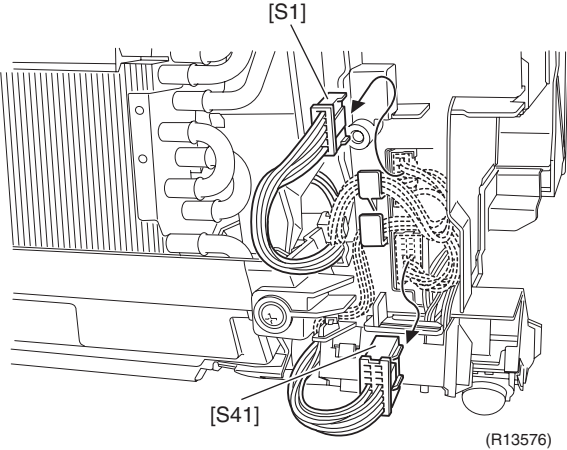
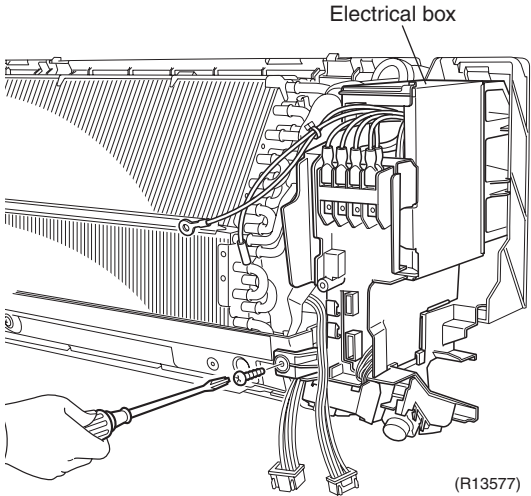
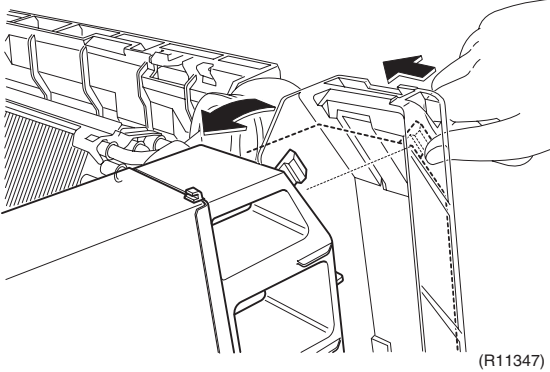
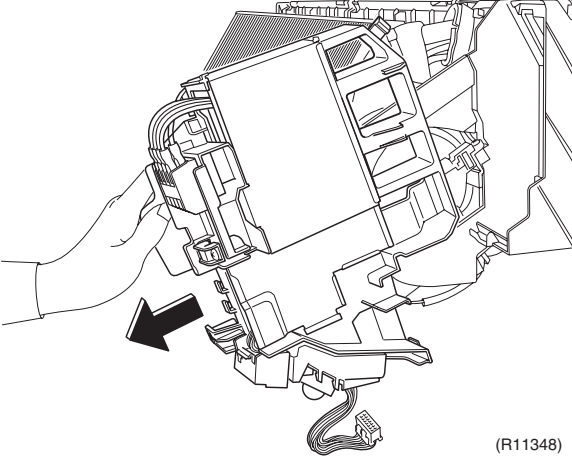
Step	Procedure	Points
7	Disconnect the connectors for the fan motor [S1] and for the swing motors [S41].	 <p>(R13576)</p>
8	Remove the screw of the electrical box.	 <p>(R13577)</p>
9	Dislocate the electrical box to the left and unfasten the back hook.	 <p>(R11347)</p> <ul style="list-style-type: none"> ■ The electrical box has a hook on its back.
10	Pull the electrical box out.	 <p>(R11348)</p> <ul style="list-style-type: none"> ■ Catch the back hook of the electrical box when reassembling.

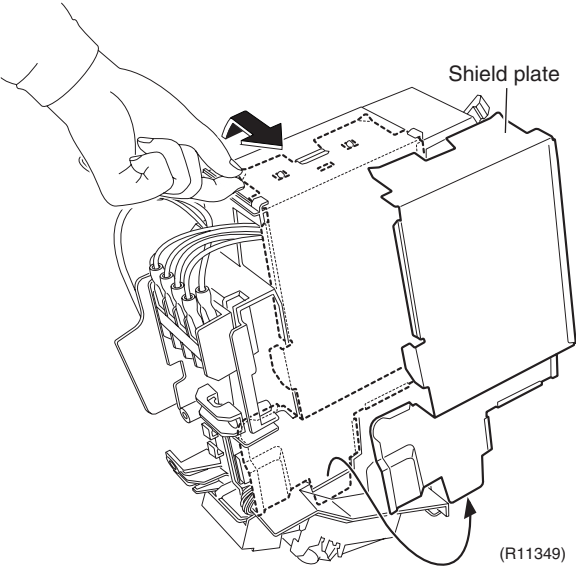
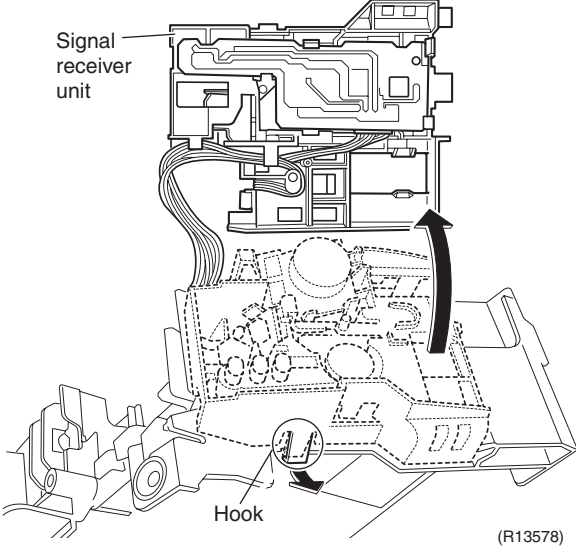
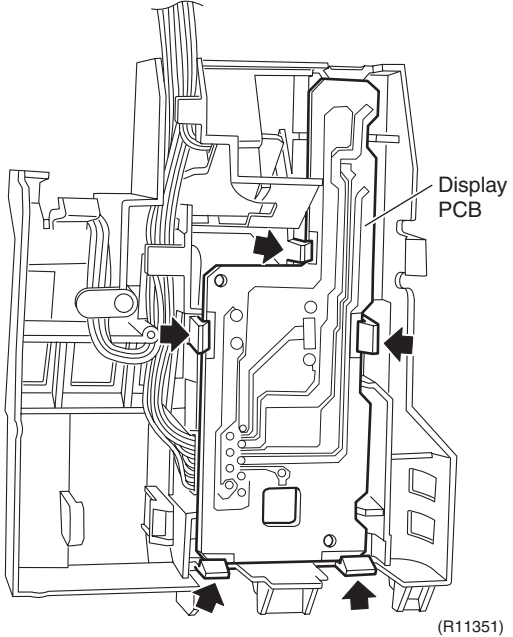
Step	Procedure	Points
<p>2. Remove the PCBs.</p> <p>1 Lift the shield plate and unfasten the hook.</p> <p>2 Remove the signal receiver unit by unfastening the hook.</p> <p>3 Unfasten the 5 hooks to remove the display PCB.</p>	 <p style="text-align: right;">Shield plate</p> <p style="text-align: right;">(R11349)</p>  <p style="text-align: left;">Signal receiver unit</p> <p style="text-align: center;">Hook</p> <p style="text-align: right;">(R13578)</p>  <p style="text-align: right;">Display PCB</p> <p style="text-align: right;">(R11351)</p>	<p>■ Unfasten the hook on the upper side.</p>

Step	Procedure	Points
4	Disconnect the connector [S49] from the display PCB.	
5	Unfasten the 4 hooks. Remove the INTELLIGENT EYE sensor PCB, and disconnect the connector [S36].	
6	Unfasten the 2 hooks. Remove the signal receiver PCB and disconnect the connector [S48].	

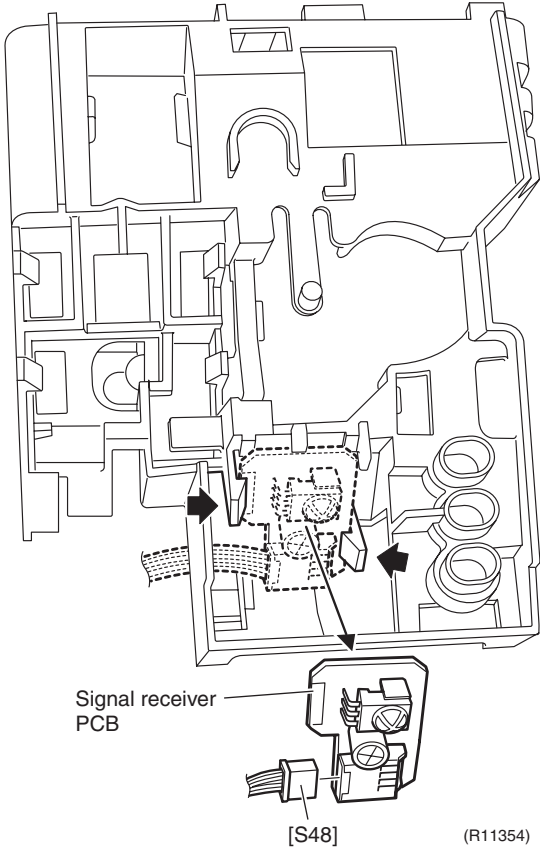
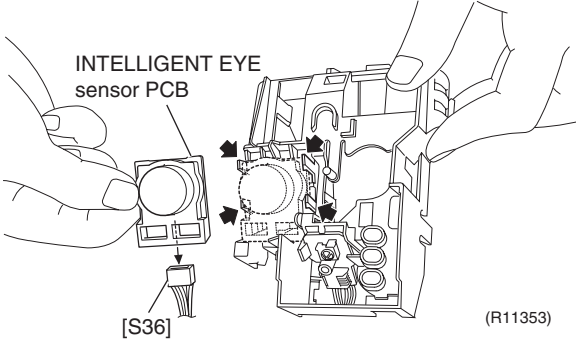
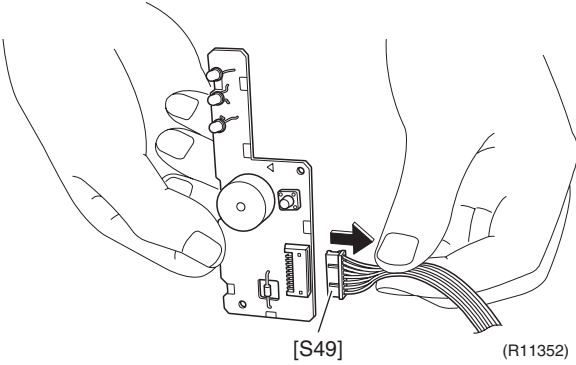

Step	Procedure	Points
7	Pull out all the harnesses from the terminal board.	
8	Unfasten the 3 hooks and remove the control PCB.	

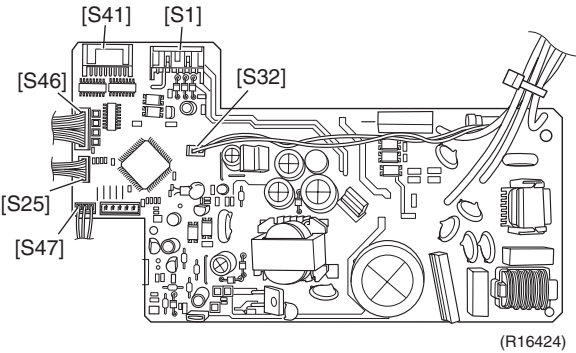
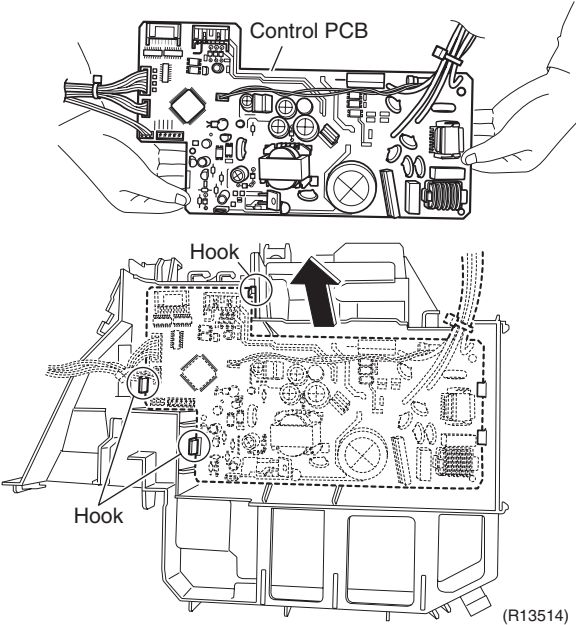
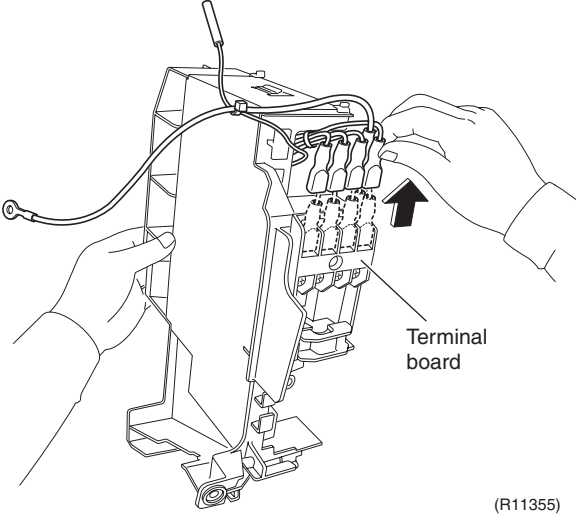

- [S1] : DC fan motor
- [S25]: INTELLIGENT EYE sensor PCB
- [S32]: indoor heat exchanger thermistor
- [S41]: swing motors
- [S46]: display PCB
- [S47]: signal receiver PCB

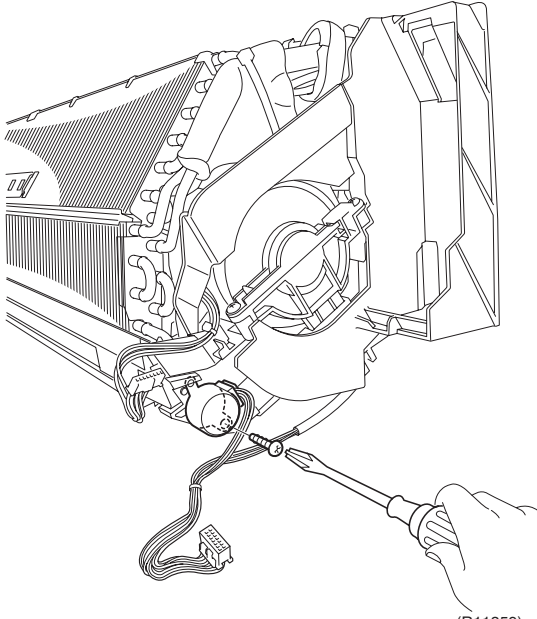
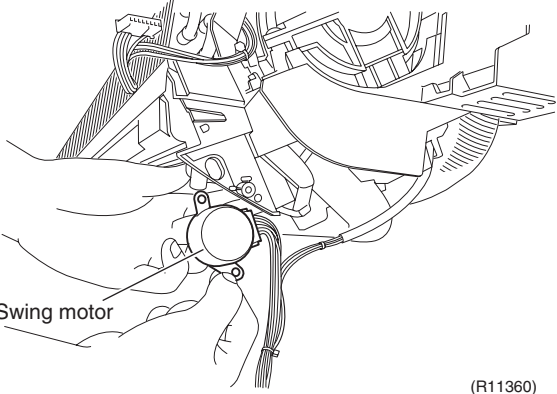
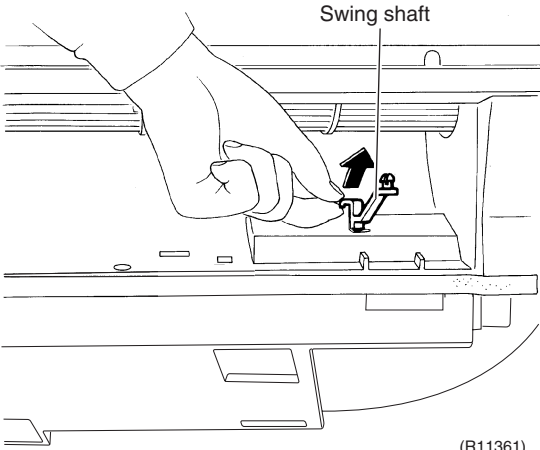
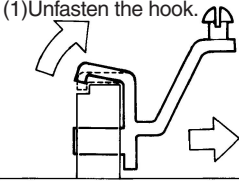
Step	Procedure	Points
<p>3. Remove the swing motor for horizontal blades.</p>	<p>1 Remove the screw of the swing motor.</p>  <p>(R11359)</p> <p>2 Remove the swing motor for horizontal blades.</p>  <p>Swing motor</p> <p>(R11360)</p>	
<p>4. Remove the swing motor for vertical blades.</p>	<p>1 Remove the swing shaft on the right side.</p>  <p>Swing shaft</p> <p>(R11361)</p>	<p>■ Remove the swing shaft.</p> <p>(1) Unfasten the hook.</p>  <p>(2) Pull out the swing shaft.</p> <p>(R9075)</p>

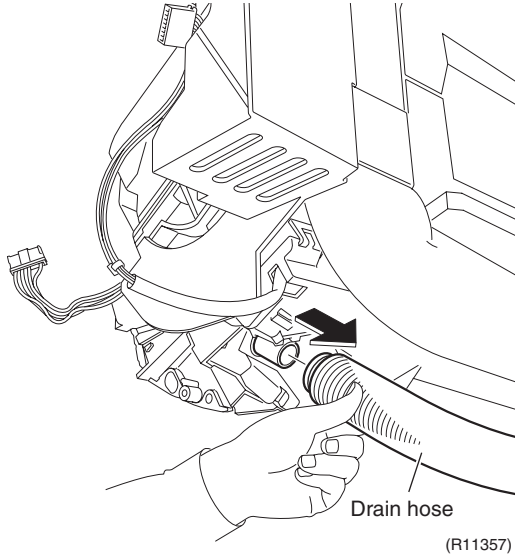
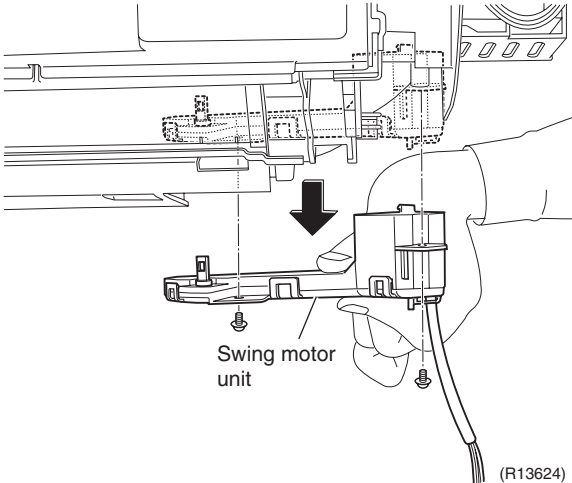
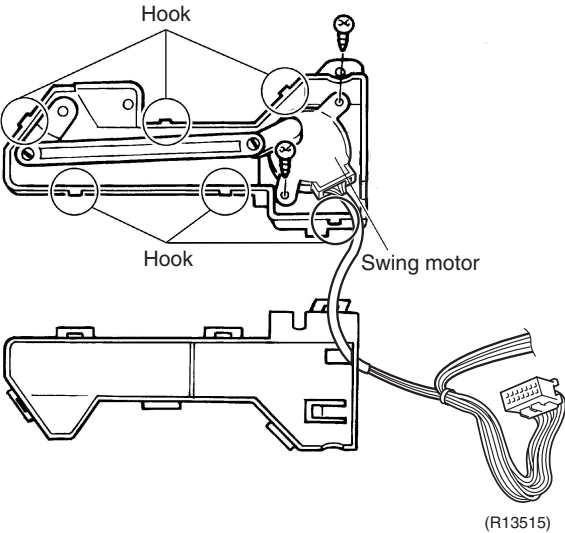
Step	Procedure	Points
2	<p>Pull out the drain hose.</p> 	
3	<p>Remove the 2 screws and detach the swing motor unit.</p> 	<ul style="list-style-type: none"> ■ In case that you cannot remove the swing motor unit easily, remove the auxiliary piping first. Refer to the "Removal of Indoor Heat Exchanger".
4	<p>Remove the 2 screws and remove the swing motor for vertical blades.</p> 	<ul style="list-style-type: none"> ■ The assembly has 6 hooks.

5. Removal of Indoor Heat Exchanger

Procedure



Warning Be sure to wait for 10 minutes or more after turning off all power supplies before disassembling work.

Step	Procedure	Points
1.	Disconnect the refrigerant piping.	<p>Preparation</p> <ul style="list-style-type: none"> Remove the electrical box according to the “Removal of Electrical Box / PCBs / Swing Motors”.
1	Hold the indoor unit up with a piece of wood etc.	<p>Caution</p> <p>From the viewpoint of global environment protection, be sure to use a vacuum pump for air purging.</p>
2	Pull out the drain hose.	<p>Caution</p> <p>In pump-down work, be sure to stop the compressor before disconnecting the refrigerant piping. If the refrigerant piping is disconnected with the compressor operating and the stop valve open, air may be sucked in and may generate an over-pressure in refrigeration cycle, thus resulting in pipe rupture or accidental injury.</p>
3	Unscrew the flare nut for gas piping.	<ul style="list-style-type: none"> Place a plastic sheet under the drain pan to prevent from wetting the floor with remaining drain. If the drain hose is embedded in the wall, disconnect the drain hose beforehand.
4	Unscrew the flare nut for liquid piping.	<ul style="list-style-type: none"> Carry out the removal work with 2 wrenches. When the pipings are disconnected, protect both the openings of pipe and unit from entering of moisture.

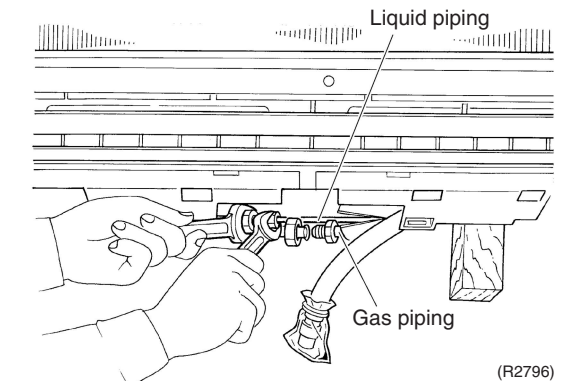
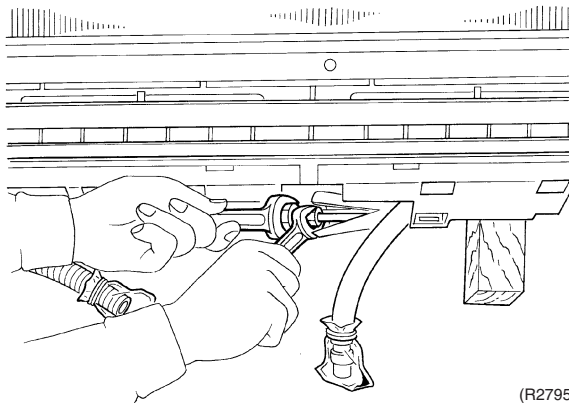
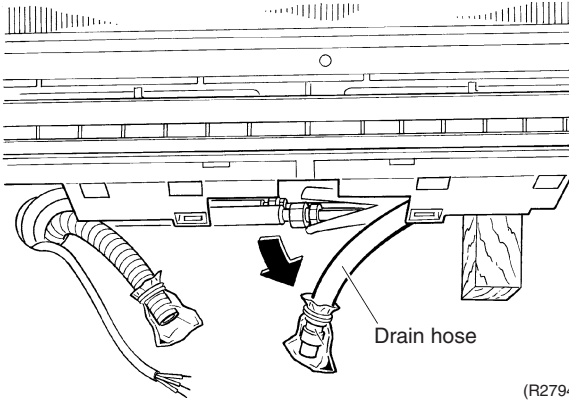
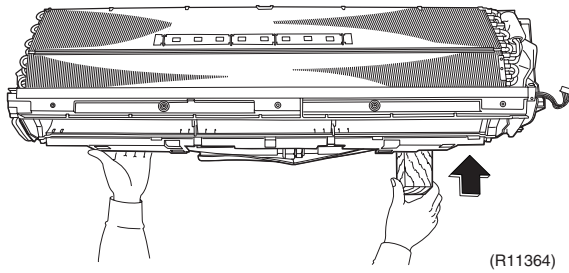

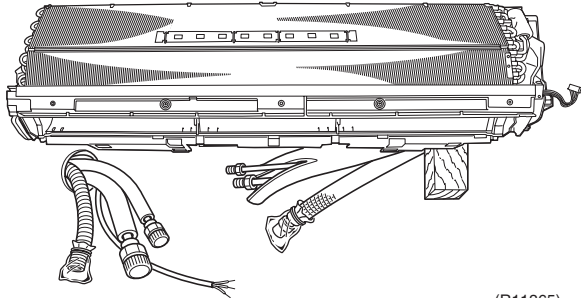
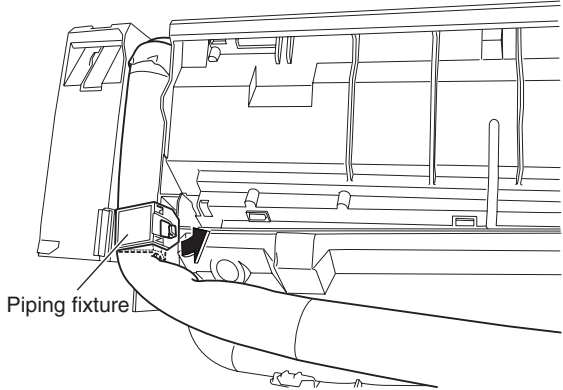
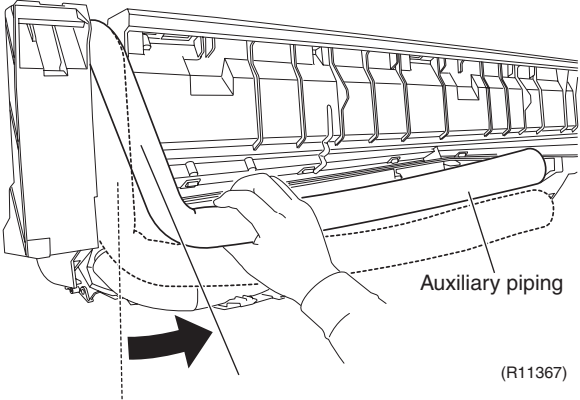
Step	Procedure	Points
2.	Remove the indoor heat exchanger.	
1	<p>Detach the indoor unit from the installation plate.</p>  <p>(R11365)</p>	
2	<p>Unfasten the hook of the piping fixture at the back of the indoor unit. Remove the piping fixture.</p>  <p>Piping fixture</p> <p>(R11366)</p>	
3	<p>Slightly widen the auxiliary piping.</p>  <p>Auxiliary piping</p> <p>(R11367)</p>	

Step	Procedure	Points
4	Unfasten the hooks on the left side.	 Caution When removing or reassembling the indoor heat exchanger, be sure to wear gloves or wrap the indoor heat exchanger with cloths. (You may be injured by the fins.)
5	Push the hooks on the right side and unfasten them.	
6	Pull the indoor heat exchanger to the front side and unfasten the hooks completely, and then lift it.	

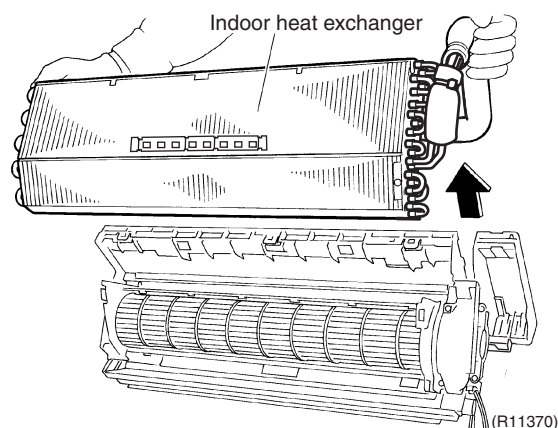
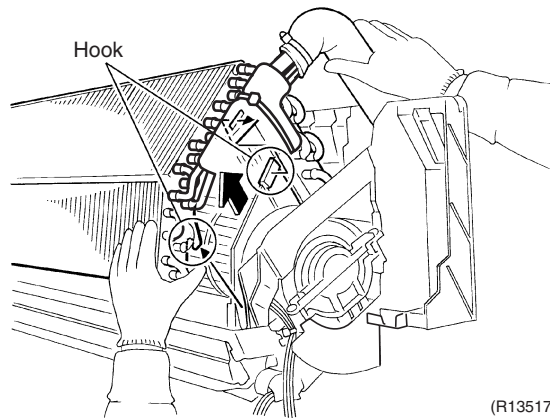
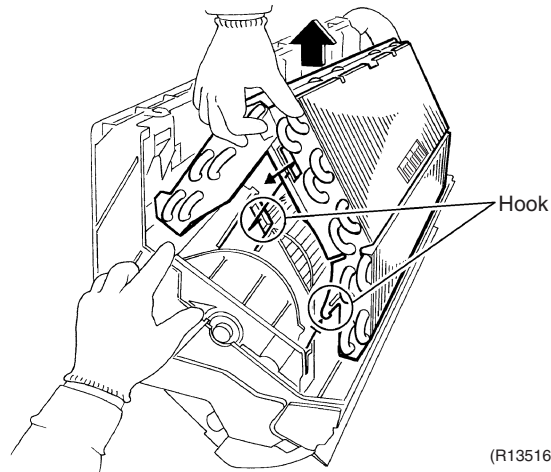

6. Removal of Fan Motor / Fan Rotor

Procedure

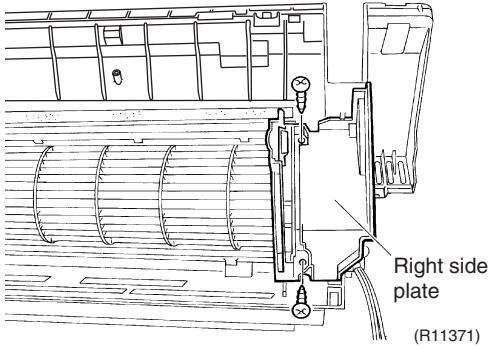
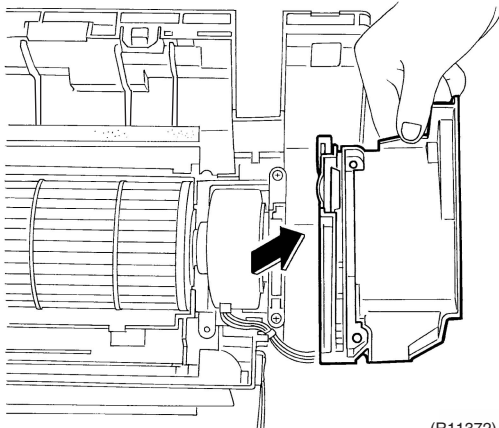
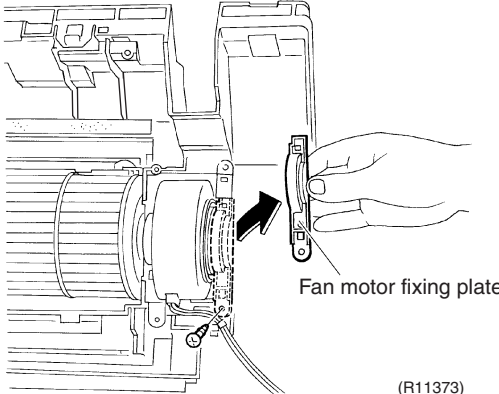
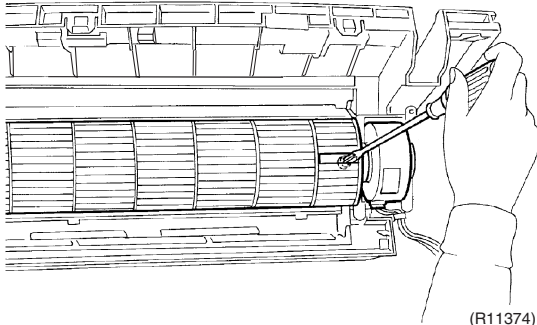

Warning Be sure to wait for 10 minutes or more after turning off all power supplies before disassembling work.

Step	Procedure	Points
<p>1. Remove the right side plate.</p> <p>1 Remove the 2 screws.</p> <p>2 Lift the right side plate and remove it.</p>	 <p>Right side plate (R11371)</p>  <p>(R11372)</p>	<ul style="list-style-type: none"> ■ You can remove the fan rotor without detaching the right side plate.
<p>2. Remove the fan motor.</p> <p>1 Remove the screw and remove the fan motor fixing plate.</p> <p>2 Loosen the screw of the fan rotor.</p>	 <p>Fan motor fixing plate (R11373)</p>  <p>(R11374)</p>	

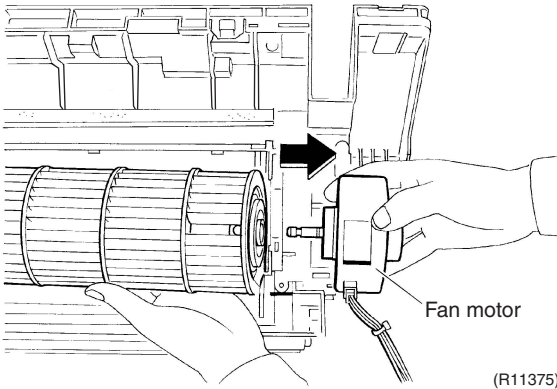
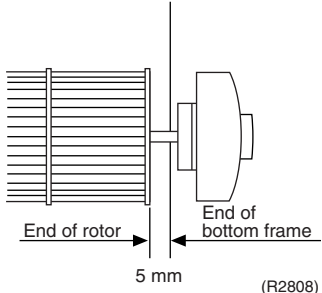
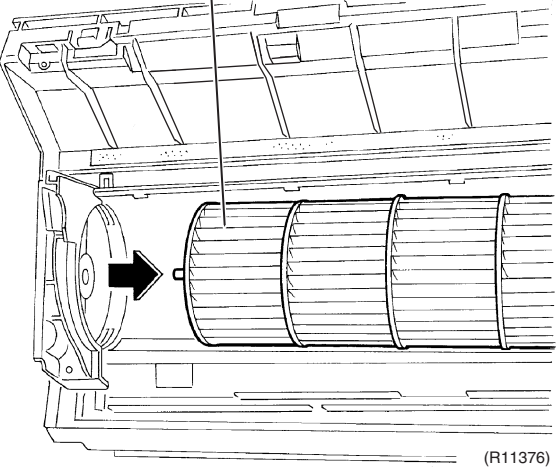
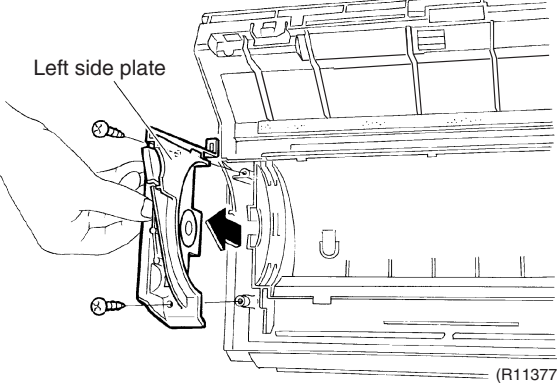
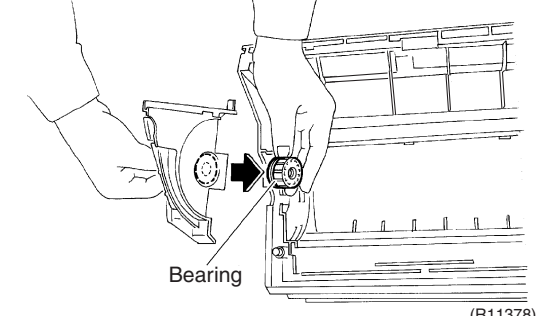
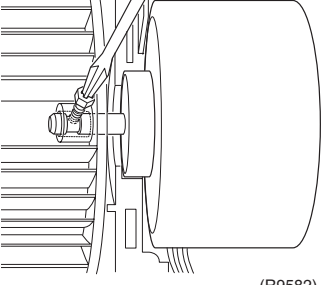
Step	Procedure	Procedure	Points
3	Remove the fan motor.		<p>■ When reassembling the fan motor and the fan rotor, provide as much as 5 mm of play between the side face of the rotor and the bottom frame.</p> 
3.	<p>Remove the fan rotor.</p> <p>1 Remove the fan rotor.</p> <p>2 Remove the 2 screws and remove the left side plate.</p> <p>3 The bearing is made of rubber. Push it inward and remove it.</p>	<p>Fan rotor</p>  <p>Left side plate</p>  <p>Bearing</p> 	 <ol style="list-style-type: none"> (1) Insert the fan motor with approx. 5 mm left. (2) Tighten the screw until it stops. Then give the screw one more turn. (3) Rotate the fan rotor and confirm the fan motor and the fan rotor are installed appropriately. (4) Tighten the screw completely if appropriate. (5) If not appropriate, go back to (1).

Revision History

Month / Year	Version	Revised contents
01 / 2013	Si041056	First edition

Warning



- Daikin products are manufactured for export to numerous countries throughout the world. Prior to purchase, please confirm with your local authorised importer, distributor and/or retailer whether this product conforms to the applicable standards, and is suitable for use, in the region where the product will be used. This statement does not purport to exclude, restrict or modify the application of any local legislation.
- Ask a qualified installer or contractor to install this product. Do not try to install the product yourself. Improper installation can result in water or refrigerant leakage, electrical shock, fire or explosion.
- Use only those parts and accessories supplied or specified by Daikin. Ask a qualified installer or contractor to install those parts and accessories. Use of unauthorised parts and accessories or improper installation of parts and accessories can result in water or refrigerant leakage, electrical shock, fire or explosion.
- Read the User's Manual carefully before using this product. The User's Manual provides important safety instructions and warnings. Be sure to follow these instructions and warnings.

If you have any enquiries, please contact your local importer, distributor and/or retailer.

Cautions on product corrosion

1. Air conditioners should not be installed in areas where corrosive gases, such as acid gas or alkaline gas, are produced.
2. If the outdoor unit is to be installed close to the sea shore, direct exposure to the sea breeze should be avoided. If you need to install the outdoor unit close to the sea shore, contact your local distributor.

Dealer

DAIKIN INDUSTRIES, LTD.

Head Office:
Umeda Center Bldg., 2-4-12, Nakazaki-Nishi,
Kita-ku, Osaka, 530-8323 Japan

Tokyo Office:
JR Shinagawa East Bldg., 2-18-1, Konan,
Minato-ku, Tokyo, 108-0075 Japan

http://www.daikin.com/global_ac/

©All rights reserved