





Si04-757

REMOVAL PROCEDURE



S E R V I C E M A N U A L

2.0/2.5/3.2/3.5 kW Class 9000/12000 Btu/h Class

-  Indoor Unit
-  Inverter / Non-Inverter
-  Wall Mounted Type



Service Manual

Removal Procedure

Indoor Unit

●Cooling Only

ATKS20DAVMB
ATKS25DAVMB
ATKS35DAVMB

FTE09GV2S
FTE12GV2S

FTE25FV1
FTE35FV1

FTKE25BVMC
FTKE35BVMC

FTKS20CAVMB
FTKS25CAVMB
FTKS35CAVMB

FTW25FV1
FTW35FV1

●Heat Pump

ATXS20DAVMB
ATXS25DAVMB
ATXS35DAVMB

FTXS09DVJU
FTXS12DVJU

FTXS20CAVMB
FTXS25CAVMB
FTXS35CAVMB

FTX25FV2C
FTX32FV2C

Table of Contents

1. Removal of Air Filter.....	2
2. Removal of Front Grille	4
3. Removal of Horizontal Blades / Vertical Blades.....	6
4. Removal of Electrical Box / PCB / Swing Motor.....	8
5. Removal of Indoor Heat Exchanger	13
6. Removal of Drain Plug (Right / Left Replacement)	16
7. Removal of Fan Rotor / Fan Motor.....	17



Note: ♦ The illustrations may be slightly different depending on the model.

1. Removal of Air Filter

Procedure



Warning Be sure to wait 10 minutes or more after turning off all power supplies before disassembling work.

Step	Procedure	Points
<p>1. External features</p>		<ul style="list-style-type: none"> ■ If ON/OFF button is pressed for 5 seconds, a forced cooling operation is carried out for approx. 15 minutes.
<p>2. Remove the air filters.</p> <p>1 Hold the protrusions on the left and right sides of the front panel and open the front panel until it stops with a click.</p> <p>2 Lift the center section of the air filter and disengage the hooks. Remove the air filter by pulling it forward.</p>		<ul style="list-style-type: none"> ■ Left and right filters are interchangeable. ■ When reassembling, insert air filter along the guide.

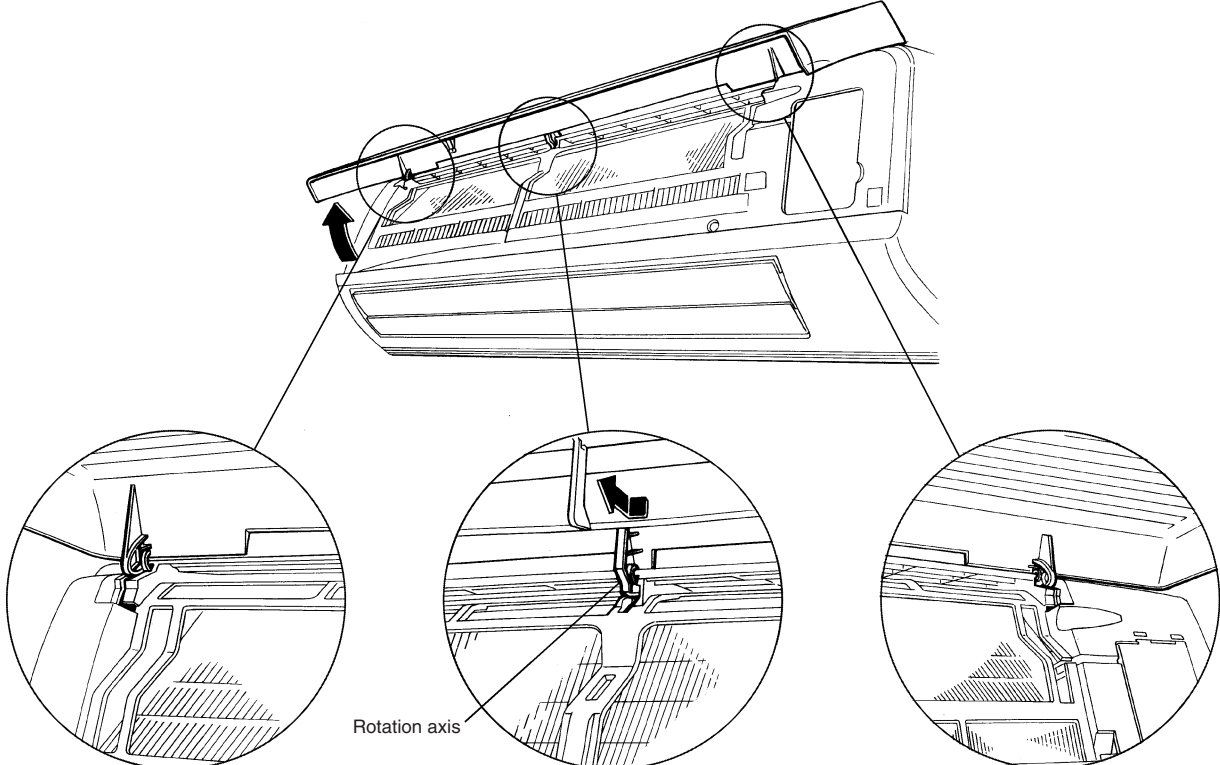
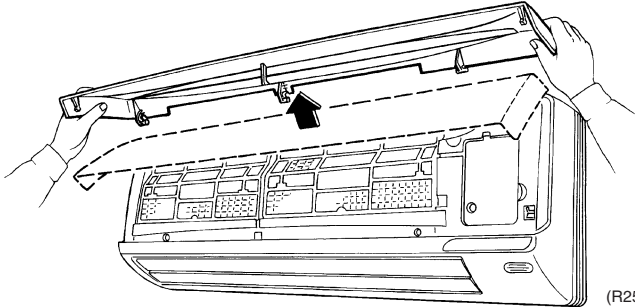
Step	Procedure	Points
<p>3. Remove the front panel.</p> <p>1 Open up the panel to the position higher than where it stops.</p>	 <p>Slide the center rotation axis to the left and remove it out.</p> <p>(R2512)</p>	<p>Support the front panel by one hand, while remove the rotation axis at the upper center by the other hand.</p>
<p>2 Remove the front panel from the unit.</p>	 <p>(R2513)</p> <p>(R2514)</p>	<p>When reassembling the front panel, make sure that the rotation axes are in the guide groove, and then shut the panel.</p>

2. Removal of Front Grille

Procedure

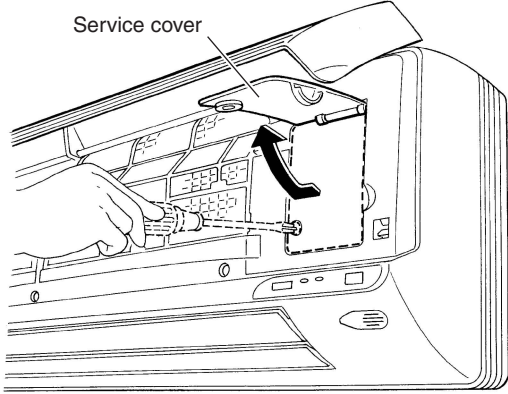
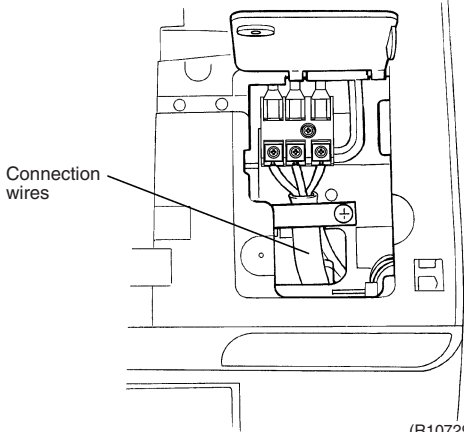
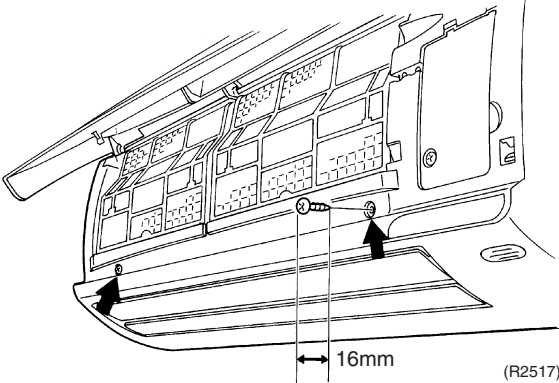
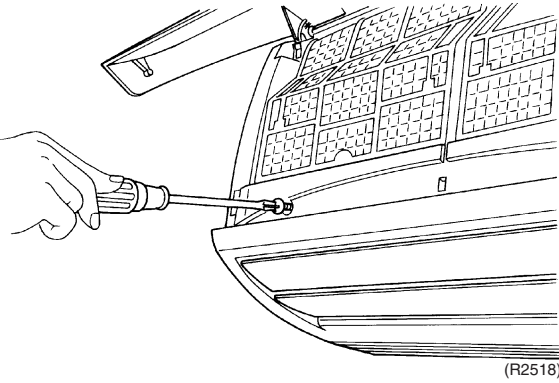

Warning Be sure to wait 10 minutes or more after turning off all power supplies before disassembling work.

Step	Procedure	Points
<p>1. Remove the service cover.</p> <p>1 Remove the screw of the service cover. Open the service cover upward.</p>	 <p>Service cover</p> <p>(R19172)</p>  <p>Connection wires</p> <p>(R10729)</p>	
<p>2. Remove the front grille assembly.</p> <p>1 Remove the 2 screws, which fix the front grille to the main body.</p>	 <p>16mm</p> <p>(R2517)</p>  <p>(R2518)</p>	

Step	Procedure	Points
2	<p>Release the 2 hooks on the upper part. In case that the hooks cannot be pressed from above, remove the front panel and then remove the front grille while pushing the hook through a clearance between the front grille and the heat exchanger.</p>	<ul style="list-style-type: none"> ■ At the upper part there are 2 hooks. ■ Release the hooks by pressing knobs with a flat screwdriver.
3	<p>The front grille can be removed by pulling out the upper part forward and lifting up the lower part.</p>	<ul style="list-style-type: none"> ■ When reassembling the front grille, make sure whether each hook is set as it was.

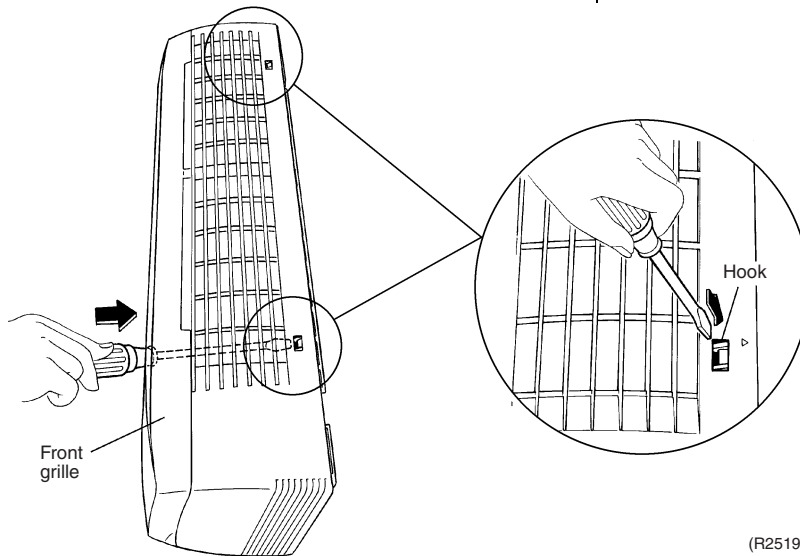

(R2519)

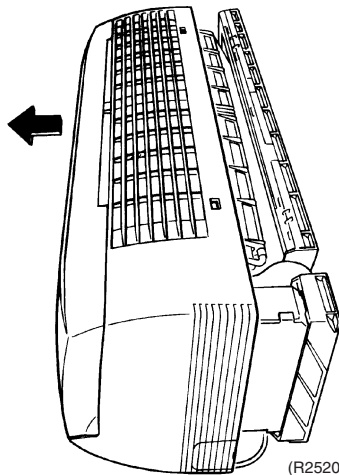

(R2520)

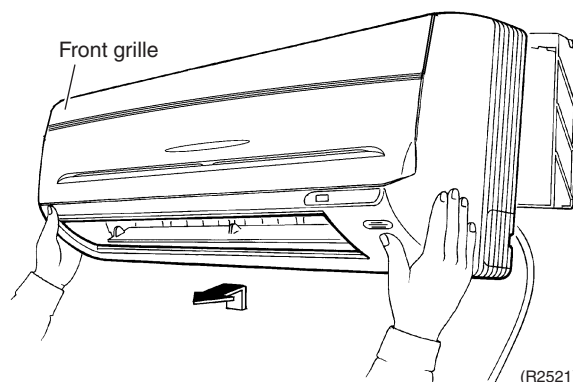

(R2521)

3. Removal of Horizontal Blades / Vertical Blades

Procedure

 **Warning** Be sure to wait 10 minutes or more after turning off all power supplies before disassembling work.

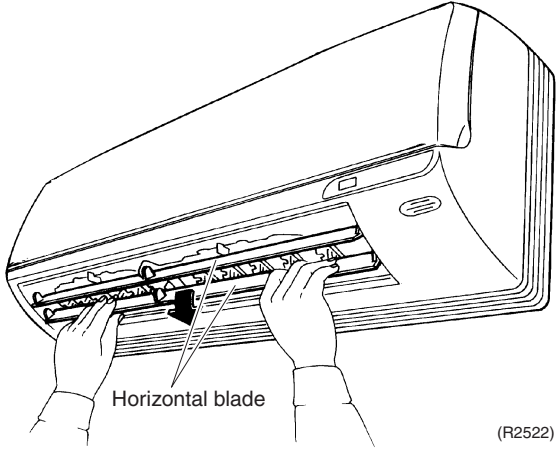
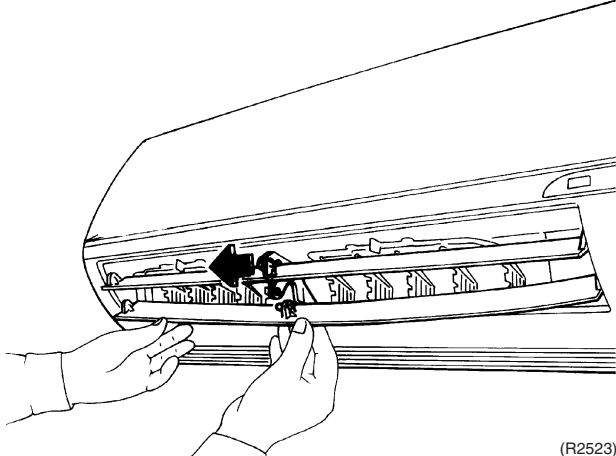
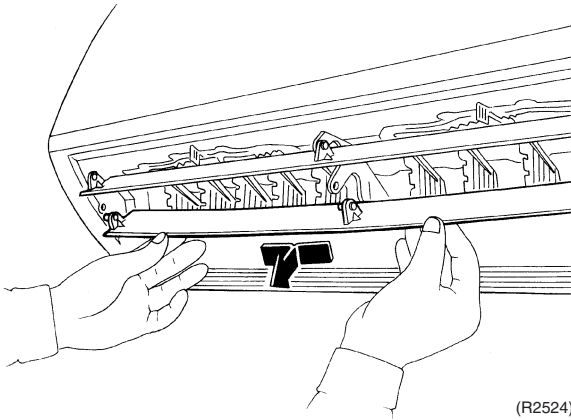
Step	Procedure	Points
1. Remove the horizontal blades.		
1 Open the horizontal blade.	 <p style="text-align: right;">(R2522)</p>	
2 Disengage the horizontal blade from the retaining section.	 <p style="text-align: right;">(R2523)</p>	
3 Bend the horizontal blade slightly and remove it from the unit.	 <p style="text-align: right;">(R2524)</p>	

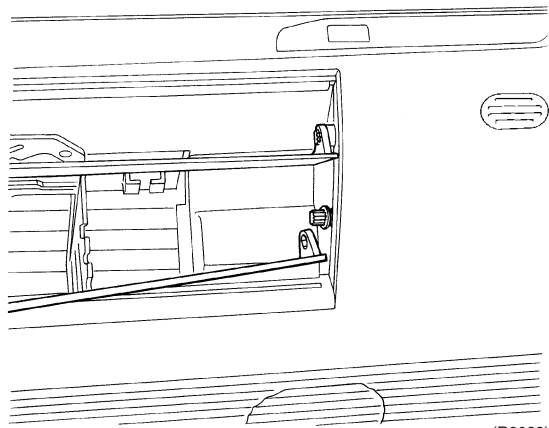
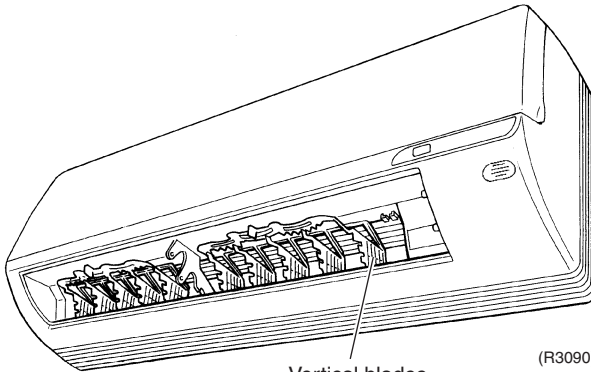
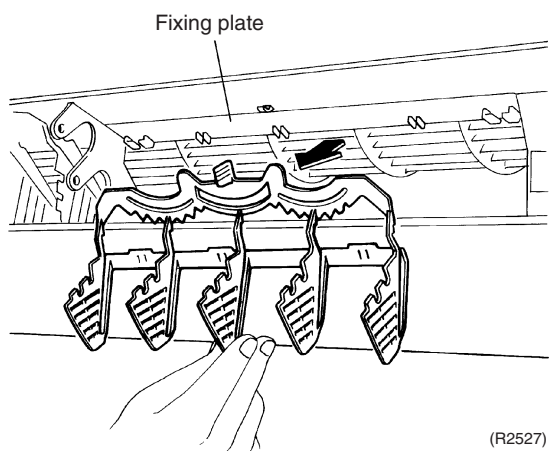
Step	Procedure	Points
	 <p style="text-align: right;">(R2032)</p>	<p>■ For reassembling.</p> <ol style="list-style-type: none"> 1. Since the key pattern hook is provided on the right side, insert the edge of the blade to the pivot while rotating it. 2. Fit the horizontal blade to the other 2 pivots.
<p>2. Remove the vertical blades.</p>	<p>1 Disengage the vertical blades from the fixing plate.</p>  <p style="text-align: center;">Vertical blades (R3090)</p> <p>2 Remove the vertical blades forward.</p>  <p style="text-align: center;">Fixing plate</p> <p style="text-align: right;">(R2527)</p>	<p>■ 5 vertical blades are integrated with the joint rod. (Only one blade cannot be exchanged.)</p>

4. Removal of Electrical Box / PCB / Swing Motor

Procedure



Warning Be sure to wait 10 minutes or more after turning off all power supplies before disassembling work.

Step	Procedure	Points
		<ul style="list-style-type: none"> Remove the front grille.
1.	Remove the electrical box.	
1	Disconnect the connecting wires.	
2	Remove the screw on the wire fixture.	
		<ul style="list-style-type: none"> Pay attention to the direction of the retainer of the thermistor so that the retainer does not touch the harness.
3	Disconnect the connectors for fan motor [S1] [S7].	
4	Disconnect the connector for swing motor [S6].	
5	Pull out the indoor heat exchanger thermistor.	
		<p>(R18519)</p>

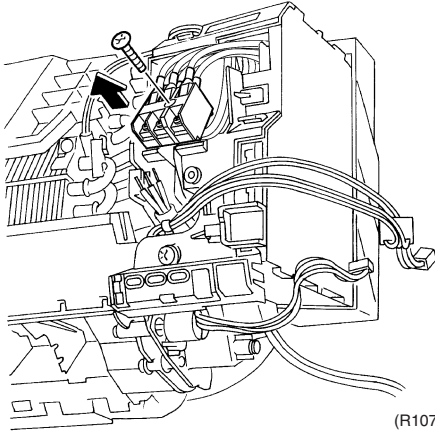
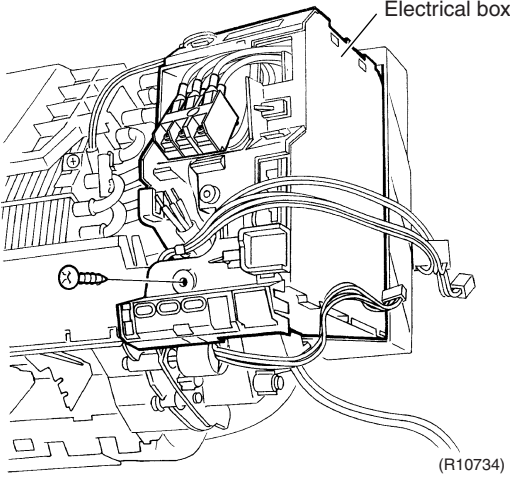
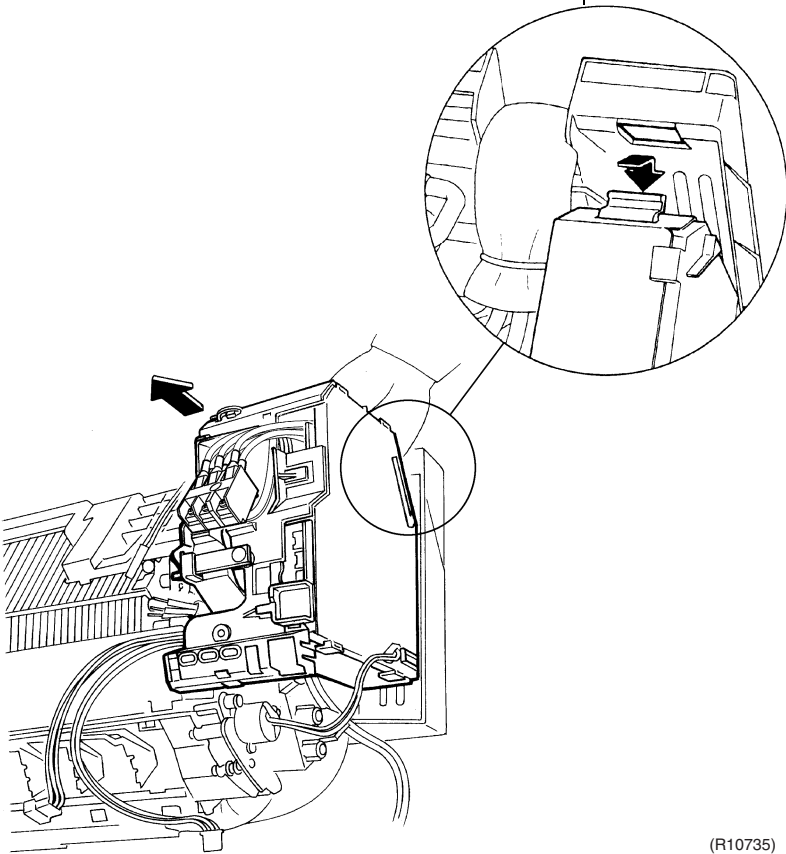
Step	Procedure	Points
6	<p>Remove the screw on the terminal board.</p>  <p>(R10733)</p>	<ul style="list-style-type: none"> ■ The electrical box can be removed without disengaging the terminal board.
7	<p>Remove the screw on the electrical box.</p>  <p>Electrical box</p> <p>(R10734)</p>	
8	<p>Pull up the electrical box forward to remove.</p>  <p>(R10735)</p>	<ul style="list-style-type: none"> ■ A hook is provided on the behind.

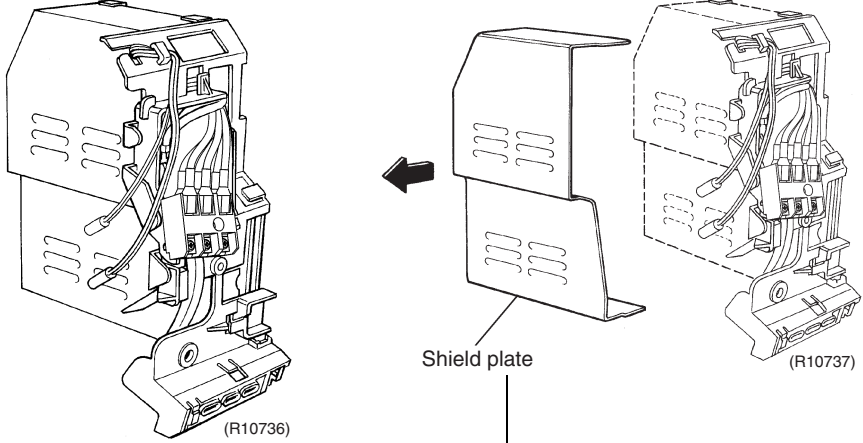
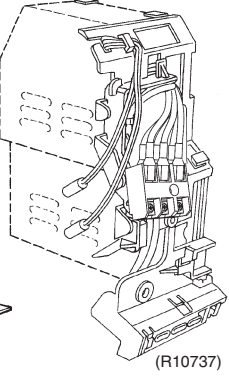
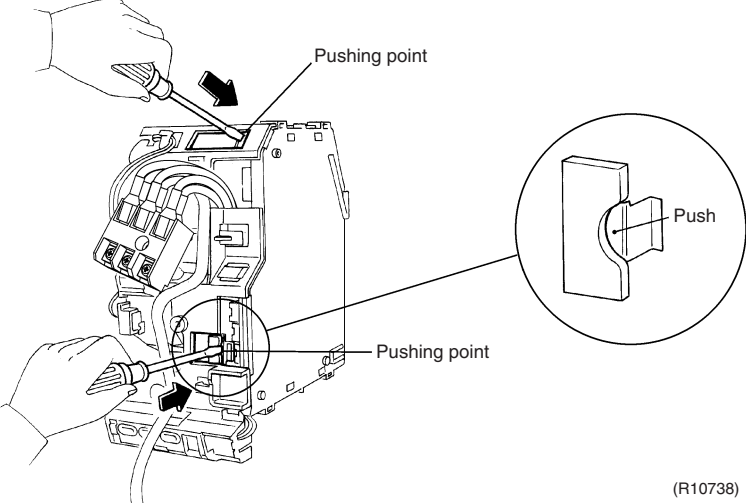
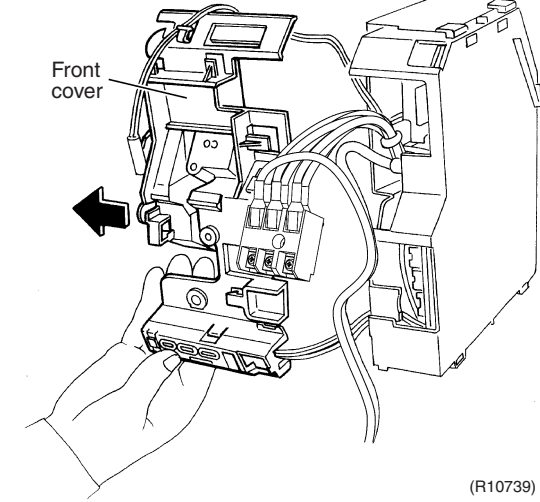
Step	Procedure	Points
2. Remove the printed circuit board (PCB).		
1 Remove the shield plate.	 <p>(R10736)</p>	 <p>(R10737)</p>
2 To remove the front cover of the electrical box, disengage the knobs by pushing the 2 hooks at the top and the bottom.	 <p>(R10738)</p>	
3 Slide the front cover of the electrical box to the left and remove it.	 <p>(R10739)</p>	

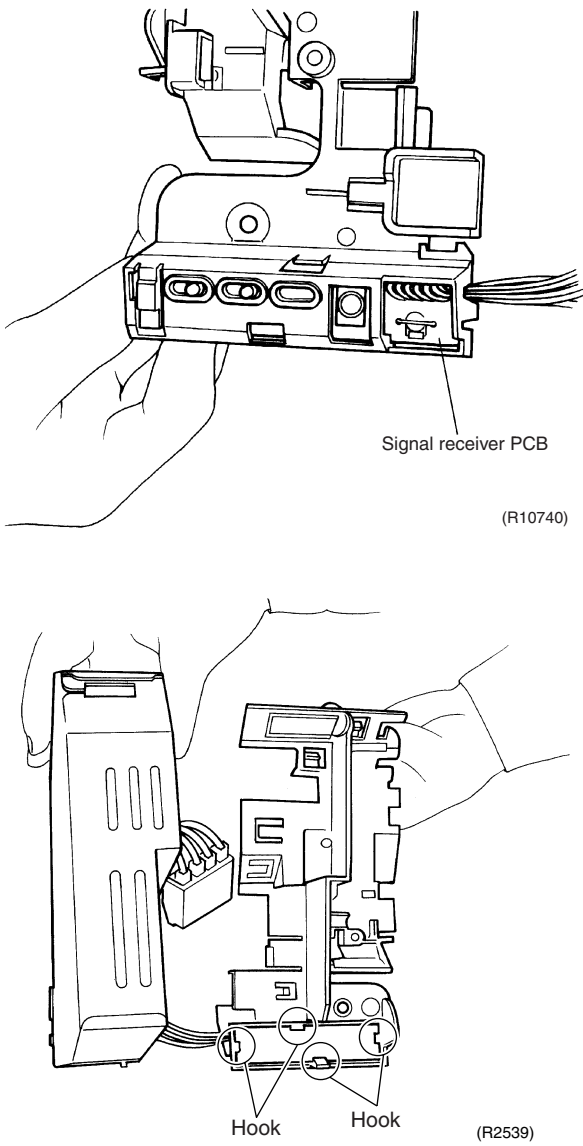
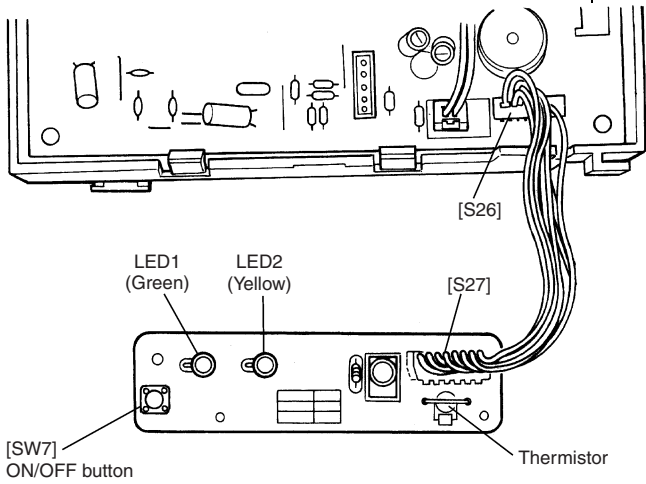
Step	Procedure	Points
<p>4</p> <p>Disengage the 4 hooks on the back of the signal receiver PCB.</p>	 <p>Signal receiver PCB</p> <p>(R10740)</p> <p>Hook Hook</p> <p>(R2539)</p>	
<p>5</p> <p>Signal receiver PCB</p>	 <p>LED1 (Green)</p> <p>LED2 (Yellow)</p> <p>[SW7] ON/OFF button</p> <p>Thermistor</p> <p>[S26]</p> <p>[S27]</p>	<p>(R18641)</p>

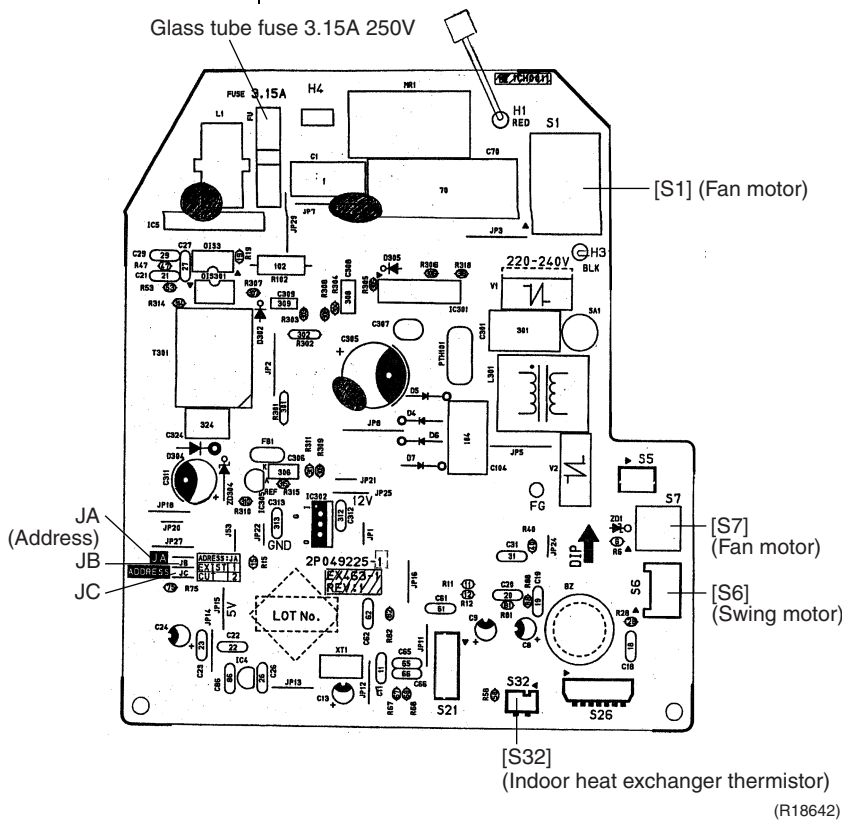
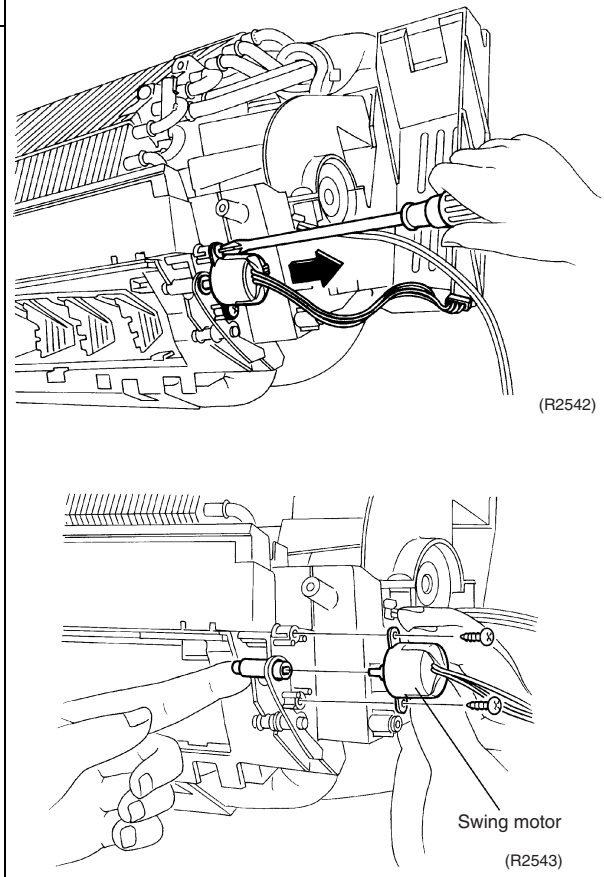
Step	Procedure	Points
6	<p>Control PCB</p>  <p>Glass tube fuse 3.15A 250V</p> <p>[S1] (Fan motor)</p> <p>[S7] (Fan motor)</p> <p>[S6] (Swing motor)</p> <p>[S32] (Indoor heat exchanger thermistor) (R18642)</p> <p>JA (Address) JB JC</p> <p>LOT No.</p> <p>2P049225-1</p>	
3.	<p>Remove the swing motor assembly.</p>	
1	<p>To remove the swing motor assembly, remove the 2 screws.</p>  <p>(R2542)</p> <p>Swing motor (R2543)</p>	

5. Removal of Indoor Heat Exchanger

Procedure

Warning Be sure to wait 10 minutes or more after turning off all power supplies before disassembling work.

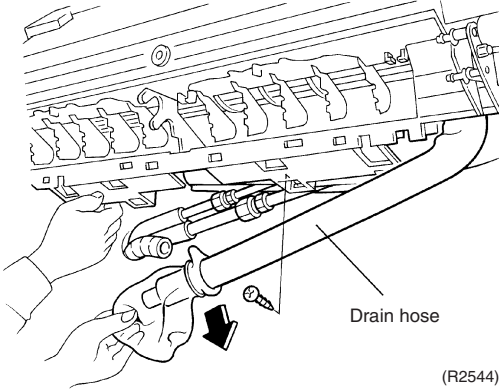
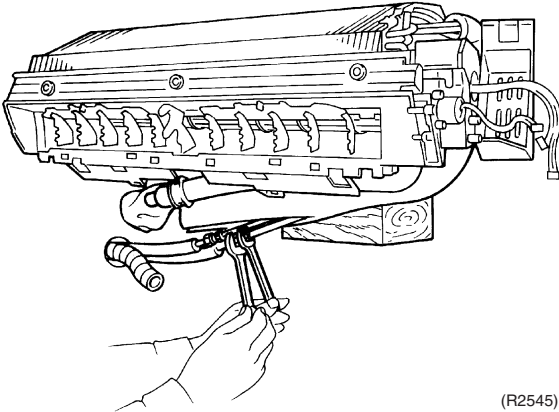
Step	Procedure	Points
<p>■ Conduct pump-down operation.</p>	<p>1 Remove the 1 screw. 2 Remove the drain hose. Make curing so that the residual drain water does not leak out.</p>  <p style="text-align: right;">(R2544)</p>	<p>Warning If refrigerant leaks, repair the leak location, then collect all refrigerant from the unit. Conduct vacuum drying, and charge proper amount of refrigerant.</p> <p>Warning Do not mix any gas (including air) other than the specified refrigerant (R-22) into refrigerating cycle. (Mixing of air or other gas causes abnormal temperature rise in refrigerating cycle, and this results in pipe rupture or personal injuries.)</p>
<p>3 Disengage the insulation tube and disconnect the flare nuts for the gas piping and the liquid piping. 4 Disengage the indoor unit from the installation plate.</p>	 <p style="text-align: right;">(R2545)</p>	<ul style="list-style-type: none"> ■ Pay attention so that the residual drain does not make the floor wet. ■ In case that a drain hose is buried inside a wall, remove it after the drain hose in the wall is pulled out. ■ Use two wrenches to disconnect the pipings. ■ After pipes are disconnected, close all pipe openings with caps to prevent dust and moisture from entering pipes.

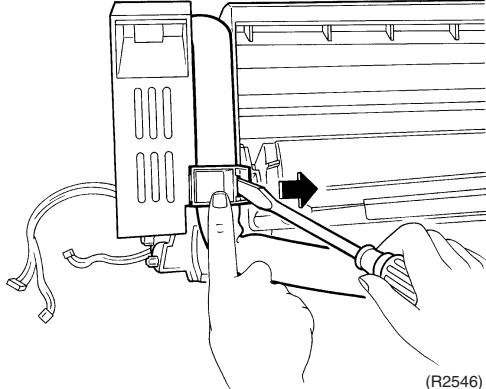
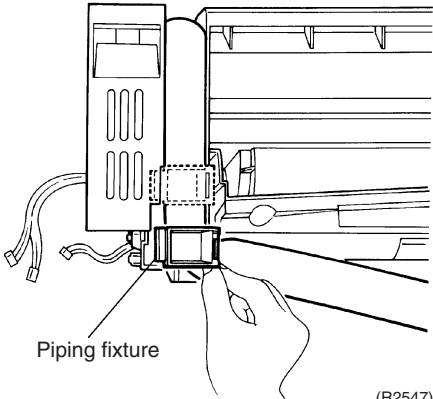
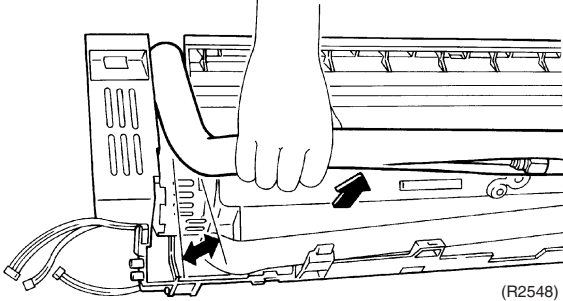
Step		Procedure	Points
5	Release the hooks of the piping fixture on the back.	 <p>(R2546)</p>  <p>Piping fixture</p> <p>(R2547)</p>	
6	Slightly widen the auxiliary piping.	 <p>(R2548)</p>	

Step	Procedure	Points
7	<p>Release the hooks and pull the indoor heat exchanger forward. The hooks are symmetrically placed in the right and the left.</p>	<p>⚠ Caution When removing or re-assembling heat exchanger, be sure to wear protective gloves or wrap indoor heat exchanger with cloths. (Fins can cut fingers.)</p> <p>■ Lift the indoor heat exchanger slightly upward to the right, and the left hook comes to be disengaged easily.</p>
8	<p>Lift and remove the indoor heat exchanger.</p>	

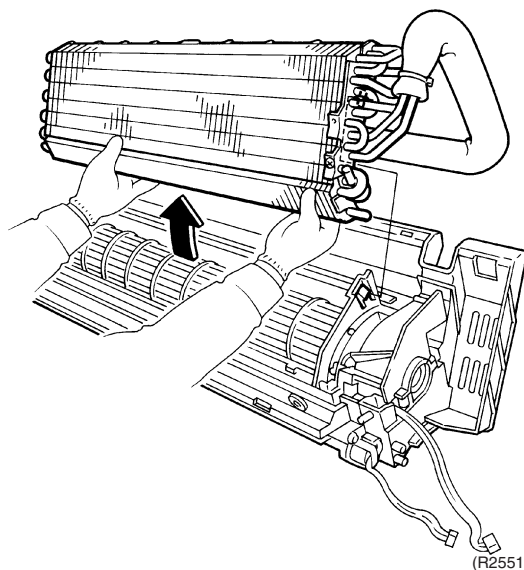
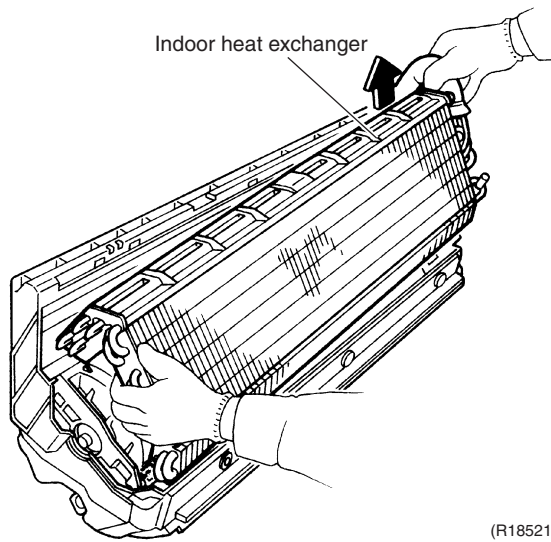
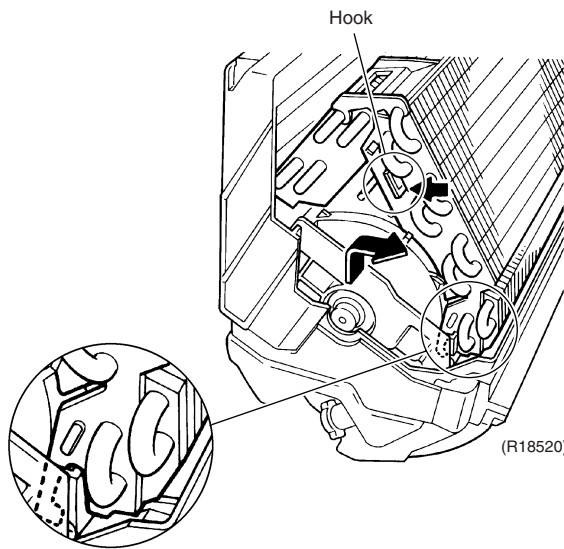

6. Removal of Drain Plug (Right / Left Replacement)

Procedure



Warning Be sure to wait 10 minutes or more after turning off all power supplies before disassembling work.

Step	Procedure	Points
1	Disconnect the drain hose.	<ul style="list-style-type: none"> ■ The drain pan is integrated with the bottom plate.
2	Pull out the drain plug from the left hole on the drain pan by hand.	<ul style="list-style-type: none"> ■ Push it into the inner part firmly.
3	Insert the drain hose.	<ul style="list-style-type: none"> ■ Push it into the inner part firmly.
4	Push the drain plug into the right hole.	

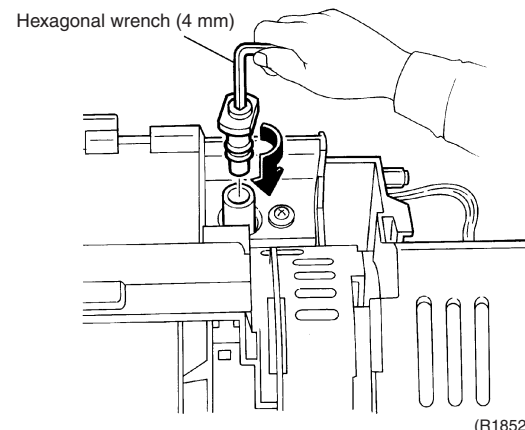
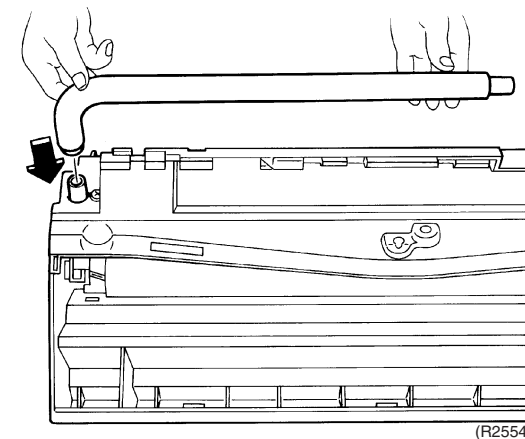
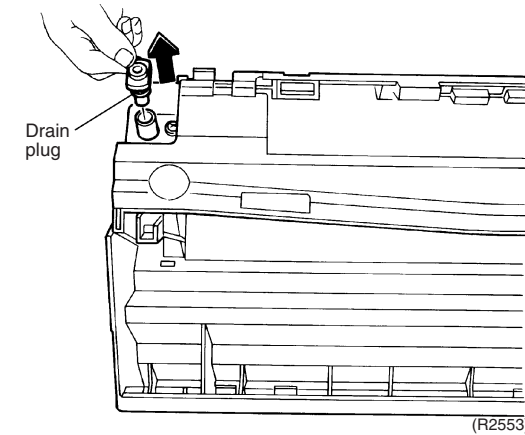
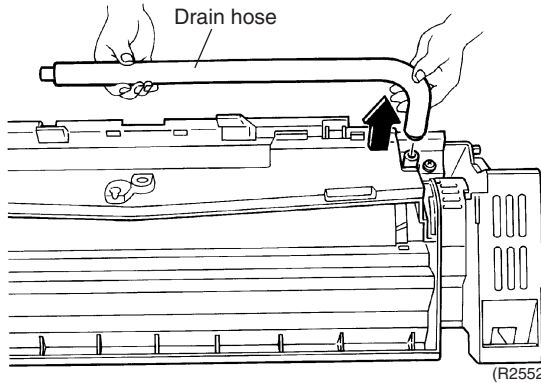

7. Removal of Fan Rotor / Fan Motor

Procedure

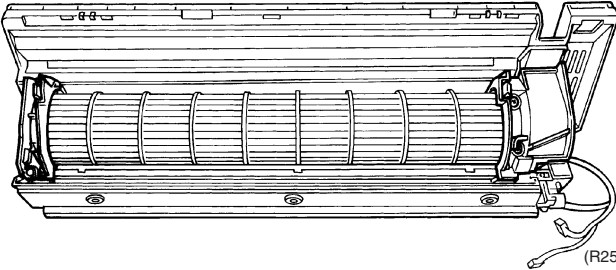
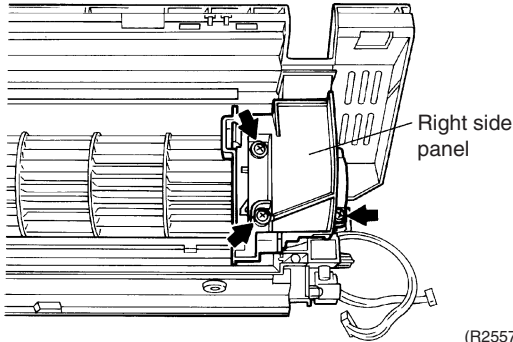
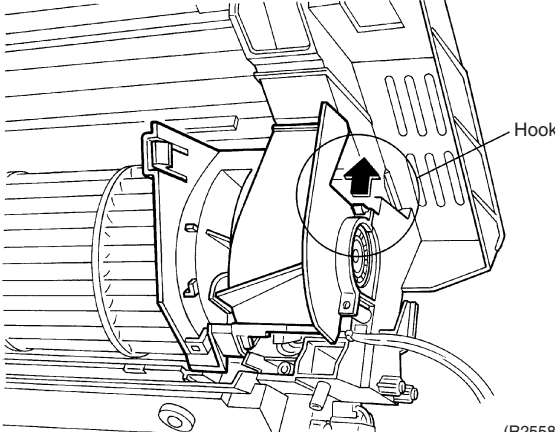
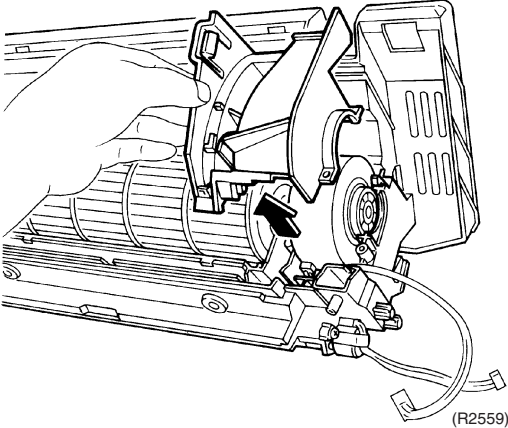
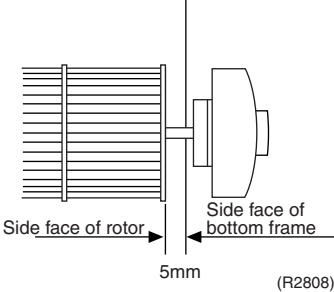
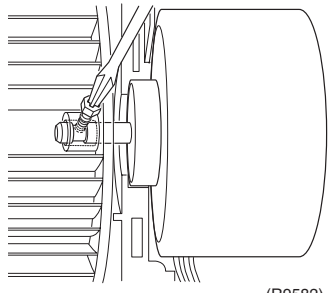

Warning Be sure to wait 10 minutes or more after turning off all power supplies before disassembling work.

Step	Procedure	Points
<p>1 To remove right side panel, remove the 3 screws.</p> <p>2 Disengage the hook and remove the right side panel.</p>	 <p>(R2556)</p>  <p>Right side panel (R2557)</p>  <p>Hook (R2558)</p>  <p>(R2559)</p>	<p>■ When reassembling the fan motor, provide as much as 5mm of play between the side face of the rotor and the bottom frame.</p>  <p>Side face of rotor Side face of bottom frame 5mm (R2808)</p>  <p>(R9582)</p> <ol style="list-style-type: none"> (1) Insert the fan motor approx. 5mm (2) Tighten the screw until it stops. Then give the screw one more turn. (3) Rotate the fan rotor and confirm the fan motor and the fan rotor are installed appropriately. (4) Tighten the screw completely if appropriate. (5) If not appropriate, go back to (1).

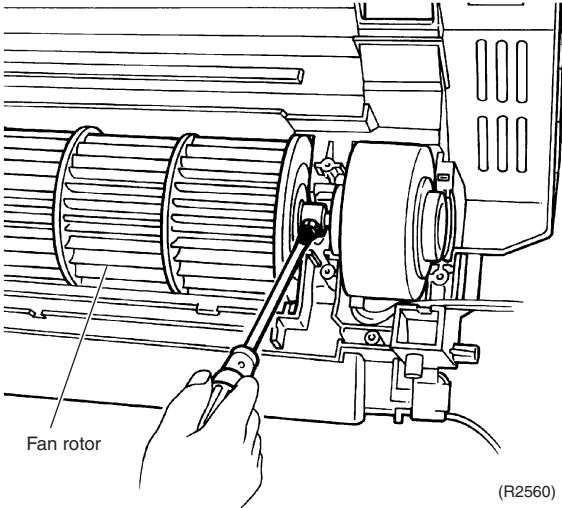
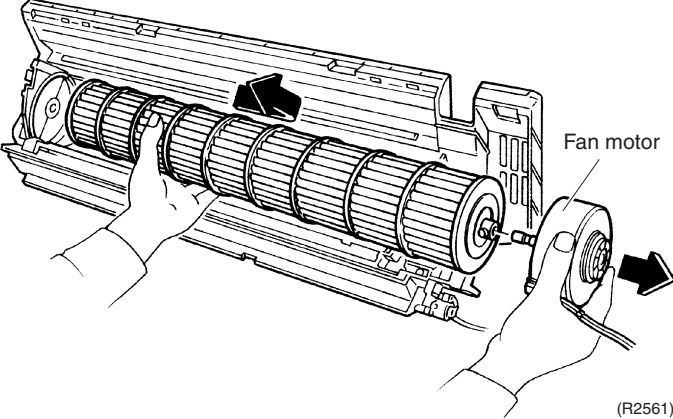
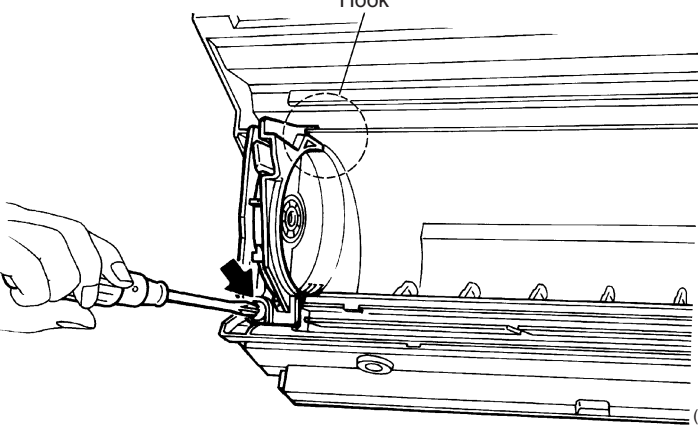
Step	Procedure	Points
3	<p>Loosen the screw on the fan rotor.</p>  <p>Fan rotor</p> <p>(R2560)</p>	
4	<p>Remove the fan motor and fan rotor.</p>  <p>Fan motor</p> <p>(R2561)</p>	
5	<p>Remove the screw on the left side panel.</p>  <p>Hook</p> <p>(R2562)</p>	

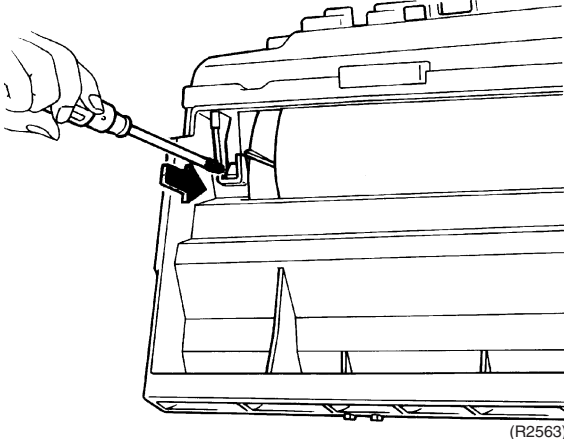
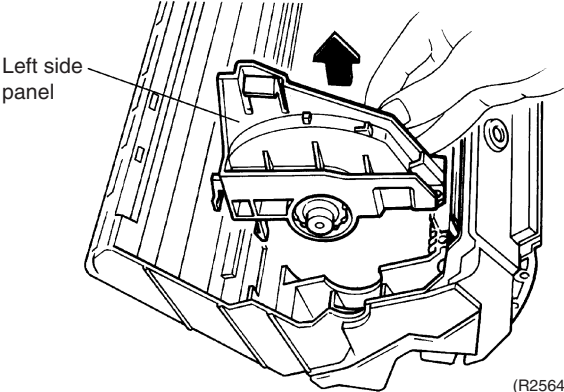
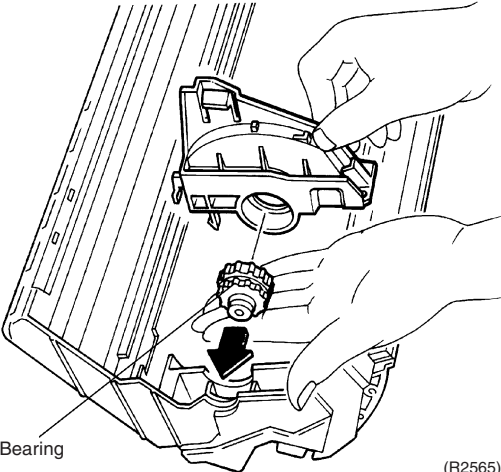
Step	Procedure	Points
<p>6</p>	<p>Release the hook from the backward and remove the left side panel.</p>  <p>(R2563)</p>  <p>Left side panel</p> <p>(R2564)</p>	
<p>7</p>	<p>Since the bearing is made of rubber, push it strongly off from the inside.</p>  <p>Bearing</p> <p>(R2565)</p>	

Revision History

Month / Year	Version	Revised contents
07 / 2013	Si04-757	First edition

Warning



- Daikin products are manufactured for export to numerous countries throughout the world. Prior to purchase, please confirm with your local authorised importer, distributor and/or retailer whether this product conforms to the applicable standards, and is suitable for use, in the region where the product will be used. This statement does not purport to exclude, restrict or modify the application of any local legislation.
- Ask a qualified installer or contractor to install this product. Do not try to install the product yourself. Improper installation can result in water or refrigerant leakage, electrical shock, fire or explosion.
- Use only those parts and accessories supplied or specified by Daikin. Ask a qualified installer or contractor to install those parts and accessories. Use of unauthorised parts and accessories or improper installation of parts and accessories can result in water or refrigerant leakage, electrical shock, fire or explosion.
- Read the User's Manual carefully before using this product. The User's Manual provides important safety instructions and warnings. Be sure to follow these instructions and warnings.

If you have any enquiries, please contact your local importer, distributor and/or retailer.

Cautions on product corrosion

1. Air conditioners should not be installed in areas where corrosive gases, such as acid gas or alkaline gas, are produced.
2. If the outdoor unit is to be installed close to the sea shore, direct exposure to the sea breeze should be avoided. If you need to install the outdoor unit close to the sea shore, contact your local distributor.

Dealer

DAIKIN INDUSTRIES, LTD.

Head Office:
Umeda Center Bldg., 2-4-12, Nakazaki-Nishi,
Kita-ku, Osaka, 530-8323 Japan

Tokyo Office:
JR Shinagawa East Bldg., 2-18-1, Konan,
Minato-ku, Tokyo, 108-0075 Japan

http://www.daikin.com/global_ac/

©All rights reserved