





Si011356EA

REMOVAL PROCEDURE



S E R V I C E M A N U A L

2.5 kW Class 9000 Btu/h Class

-  Outdoor Unit
-  Non-Inverter
-  Pair Type



Service Manual Removal Procedure

Outdoor Unit

●Cooling Only

ARM09MV2S

RM09NV2S

RM25JV14

RM25KV1V

RN25JV1G

Table of Contents

1. Outer Panels	2
2. Outdoor Fan / Fan Motor.....	4
3. Electrical Components	6
4. Sound Blankets.....	10
5. Capillary Tube	11
6. Compressor ASSY	12



Note: ♦ The illustrations may be slightly different depending on the model.

1. Outer Panels



Warning

◆ Be sure to wait for 10 minutes or more after turning off all power supplies before disassembling work.

Step	Procedure	Points
1	Remove the screw and remove the stop valve cover.	<ul style="list-style-type: none"> ■ The stop valve cover is united with the shield plate. ■ When reassembling, make sure to fit the 3 hooks.
2	Remove the 3 screws (left: 2 screws, right: 1 screw) and remove the top panel.	
3	Remove the 6 screws of the front panel.	

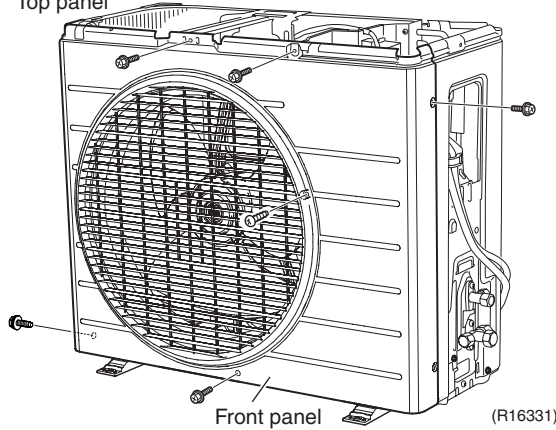
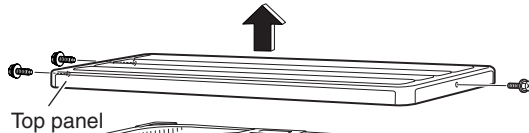
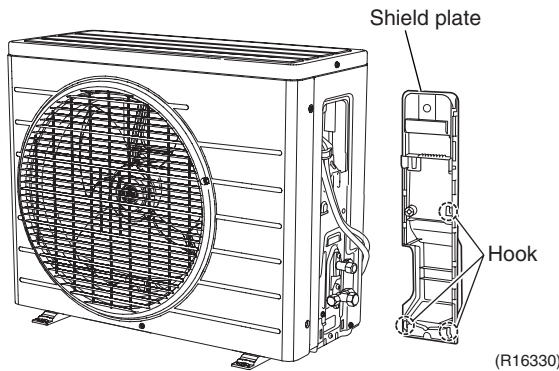
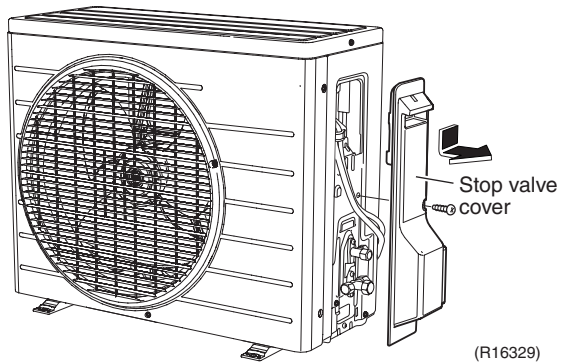

Step	Procedure	Points
4	Lift up the left side and unfasten the hooks.	
5	Release the right side hooks and remove the front panel.	
6	Press the 2 projections from the rear side and rotate the discharge grille to remove it.	

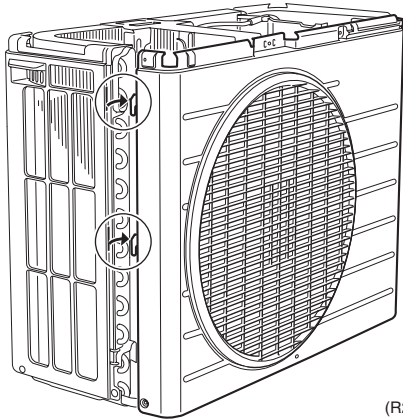

(R20743)

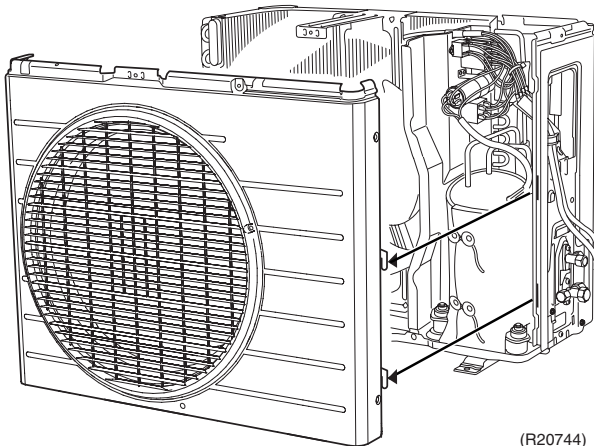

(R20744)

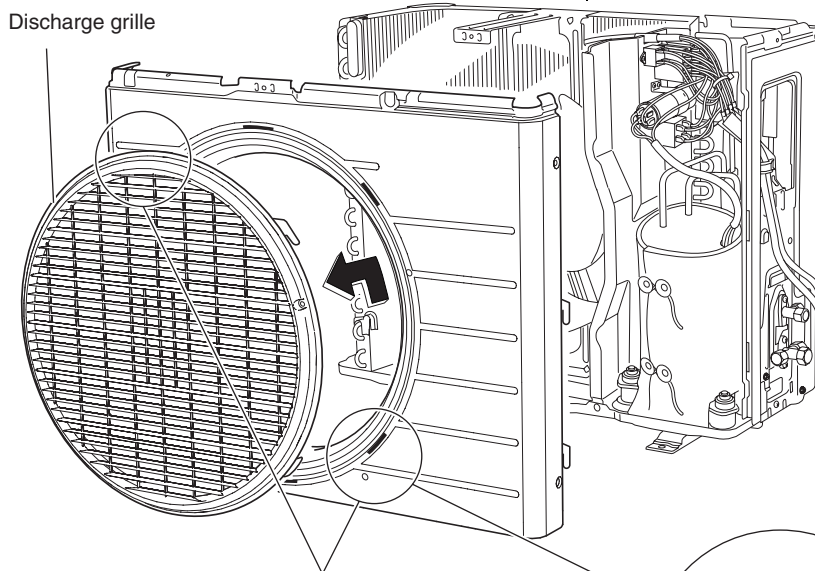

Projection (rear side)

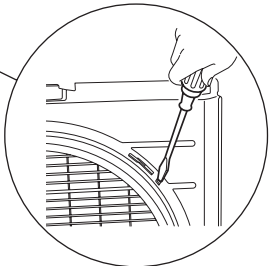

(R16323)

2. Outdoor Fan / Fan Motor



Warning

◆ Be sure to wait for 10 minutes or more after turning off all power supplies before disassembling work.

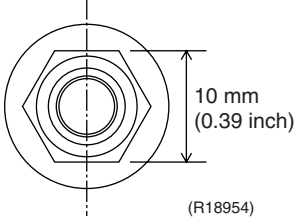
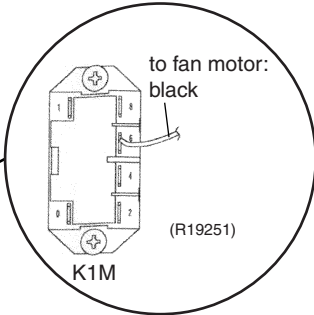
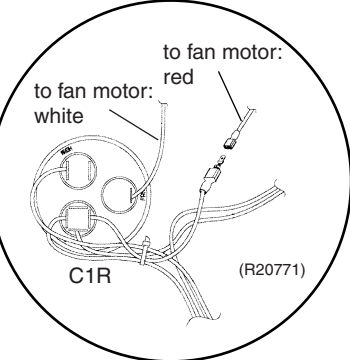
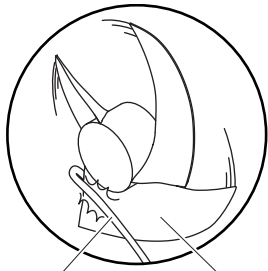
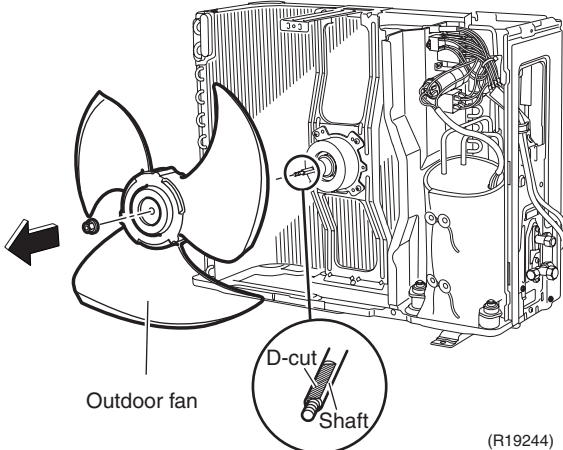
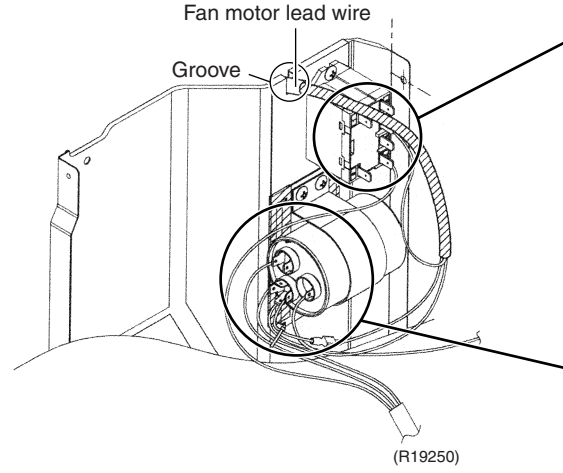
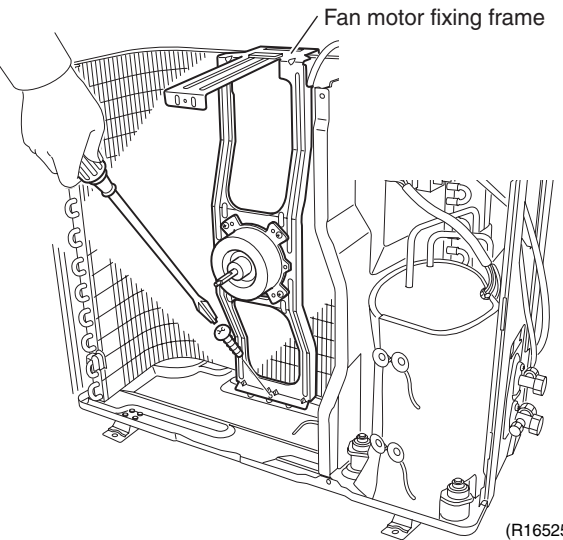
Step	Procedure	Points
1	Remove the nut of the outdoor fan.	<ul style="list-style-type: none"> ■ Nut size: M6
2	Remove the outdoor fan.	 <p>(R18954)</p> <ul style="list-style-type: none"> ■ When reassembling, align the ▼ mark of the outdoor fan with the D-cut section of the motor shaft.
3	Release the fan motor lead wire from the groove.	 <p>(R19251)</p> <p>K1M</p> <p>to fan motor: black</p>
4	Pull out the terminal (black) from the magnetic contactor K1M (6).	 <p>(R20771)</p> <p>C1R</p> <p>to fan motor: red</p> <p>to fan motor: white</p>
5	Pull out the terminal (white) from the compressor capacitor (C1R).	
6	Pull out the relay connector (red) to the fan motor.	
7	Remove the screw to detach the fan motor fixing frame.	<ul style="list-style-type: none"> ■ Put the lead wire through the back of the motor when reassembling so as not to be entangled with the outdoor fan.  <p>(R3249)</p> <p>Lead wire</p> <p>Outdoor fan</p>
	 <p>Outdoor fan</p> <p>D-cut</p> <p>Shaft</p> <p>(R19244)</p>	
	 <p>Fan motor lead wire</p> <p>Groove</p> <p>(R19250)</p>	
	 <p>Fan motor fixing frame</p> <p>(R16525)</p>	

Step	Procedure	Points
8	Remove the fan motor fixing frame.	<ul style="list-style-type: none"> When reassembling, fit the lower hooks into the bottom frame.
9	Remove the 3 screws and remove the fan motor.	<ul style="list-style-type: none"> Screw size: M4 x 16
10	Release the harness from the hooks.	
11	Remove the fan motor.	

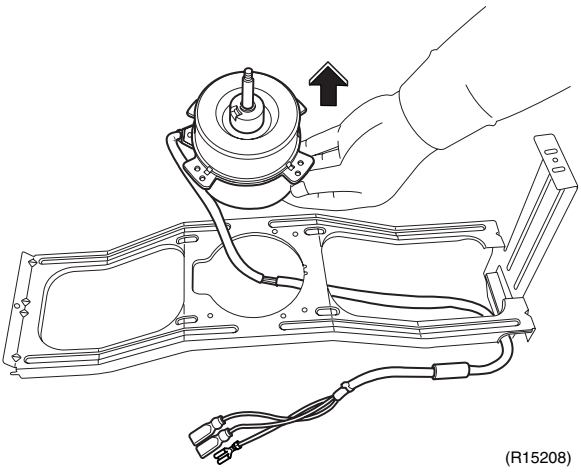
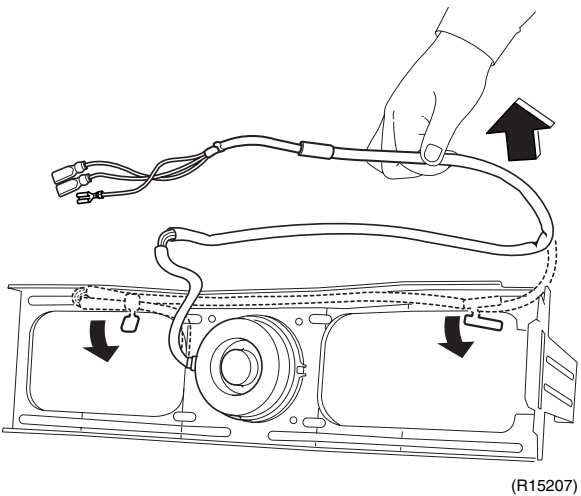
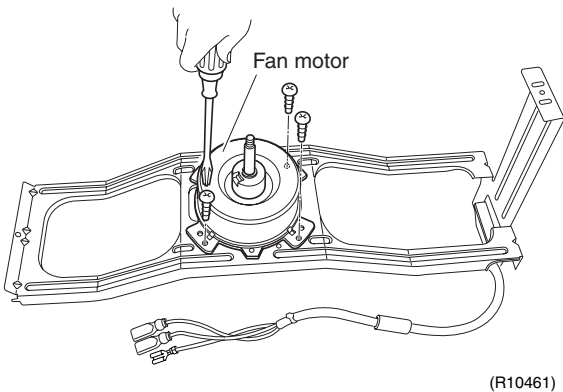
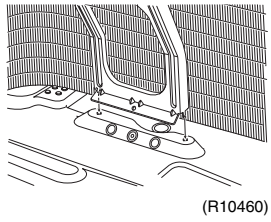
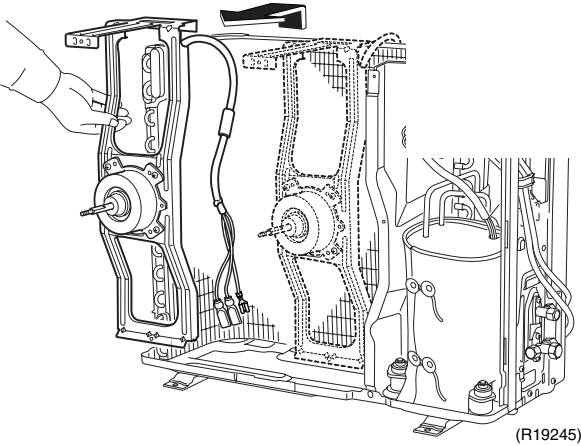

3. Electrical Components



Warning

◆ Be sure to wait for 10 minutes or more after turning off all power supplies before disassembling work.

Step	Procedure	Points
1	Remove the 7 screws on the terminal board and disconnect the connecting wire and the power supply wire.	
2	Remove the screw and remove the wire fixture.	
3	Remove the screw on the rear side.	
4	Remove the 4 screws on the right side.	

Step	Procedure	Points
5	Unfasten the upper hook.	<ul style="list-style-type: none"> When reassembling, make sure to fit the hook.
6	Unfasten the hook and remove the right side panel.	<ul style="list-style-type: none"> When reassembling, make sure to fit the hook.
7	Remove the screw of the terminal board (X1M).	

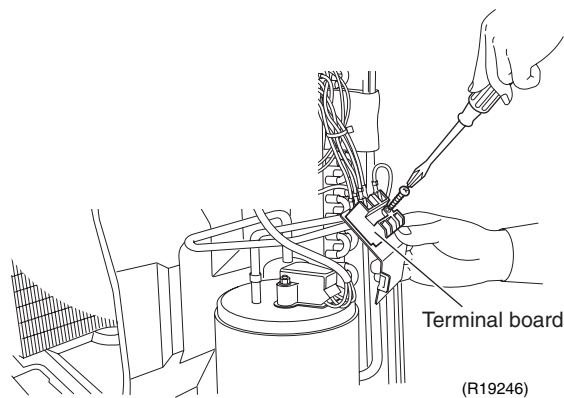
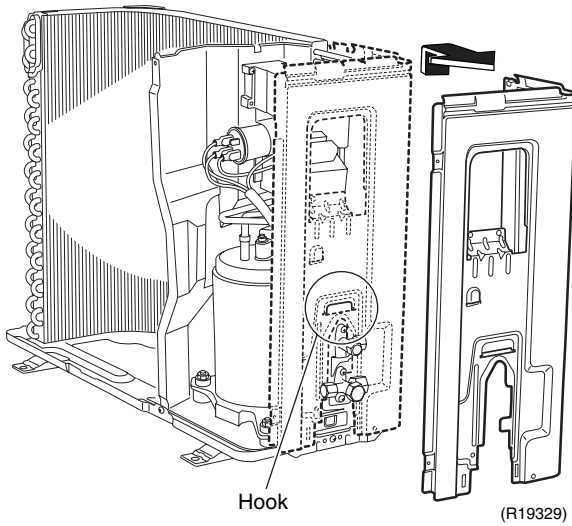
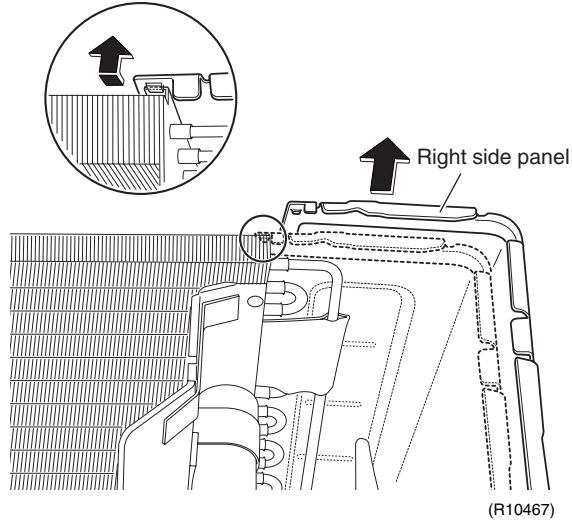

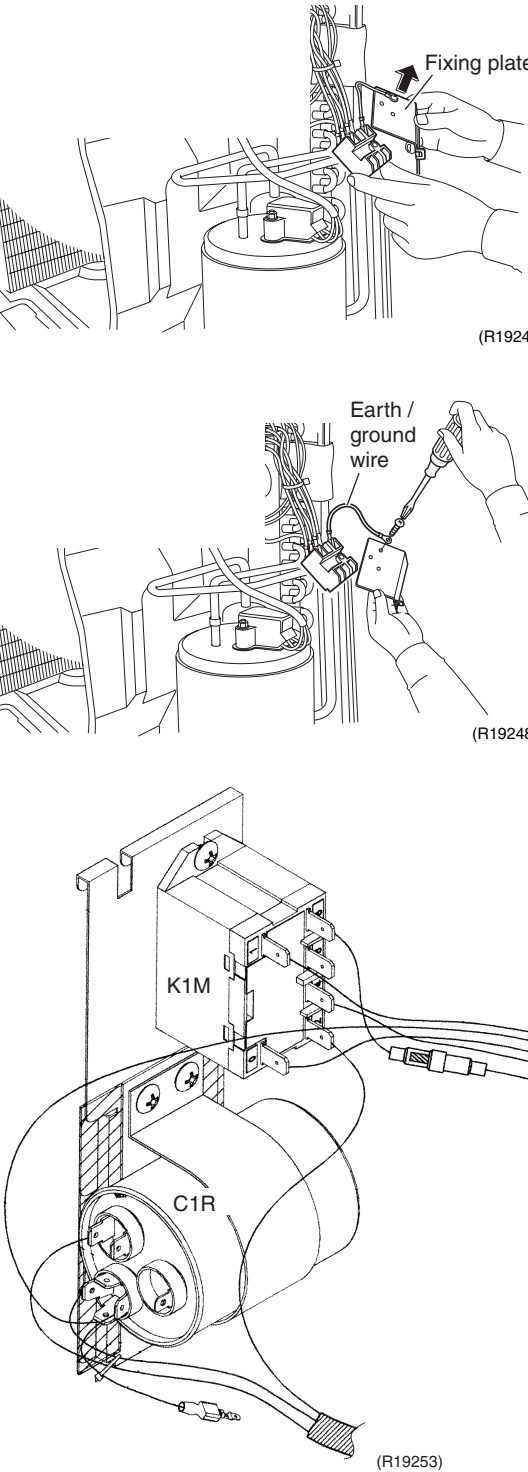
Step	Procedure	Points
8	Detach the fixing plate.	<p data-bbox="1094 987 1270 1016">■ Parts layout</p>
9	Remove the screw of the earth / ground wire.	
		

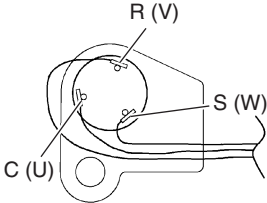
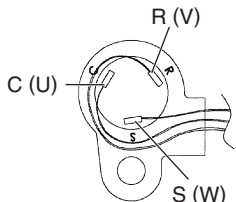
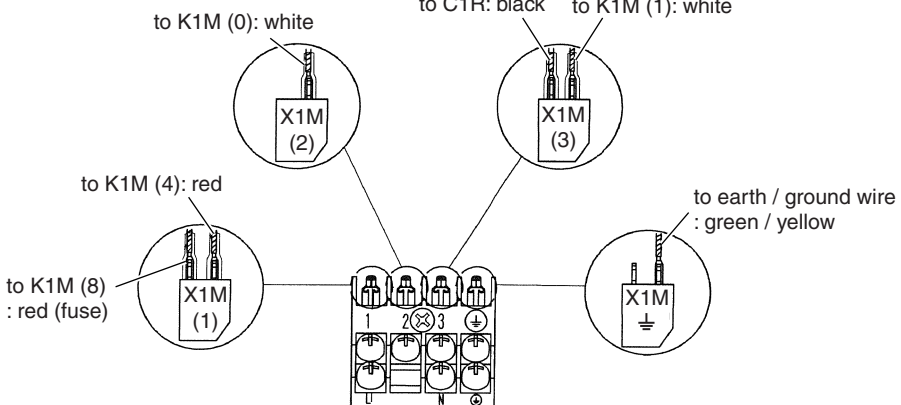
Step	Procedure	Points
10	Pull out the terminals from the magnetic contactor (K1M).	
11	Remove the 2 screws and remove the magnetic contactor (K1M).	
12	Pull out the terminals from the compressor capacitor (C1R).	<p>■ Compressor lead wire</p> <p>For R-410A models</p>  <p>(R15375)</p>
13	Remove the 2 screws to loosen the capacitor fixing band and remove the compressor capacitor (C1R).	<p>For R-32 models</p>  <p>(R20742)</p> <p>S (W): yellow C (U): blue R (V): red</p>
14	Pull out the harnesses from the terminal board (X1M).	 <p>(R20741)</p>

4. Sound Blankets



Warning

◆ Be sure to wait for 10 minutes or more after turning off all power supplies before disassembling work.

Step	Procedure	Points
1	Remove the sound blanket (top).	<ul style="list-style-type: none"> ■ Since the piping ports on the sound blanket are torn easily, remove the sound blanket carefully.
2	Untie the 2 strings and open the sound blanket (body).	<ul style="list-style-type: none"> ■ The design of the sound blankets varies depending on the model.
3	Remove the sound blanket (body).	

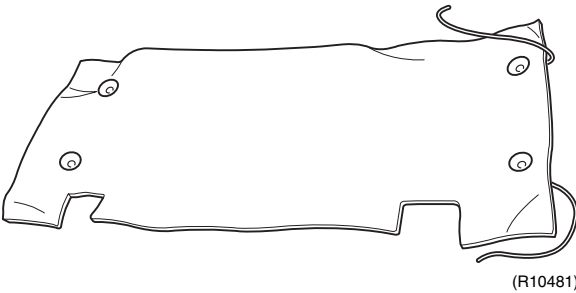
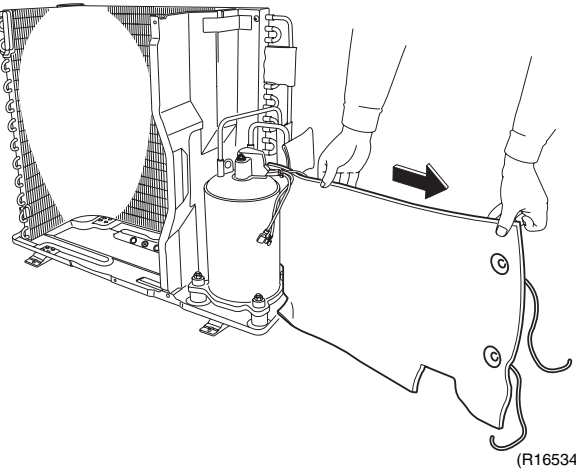
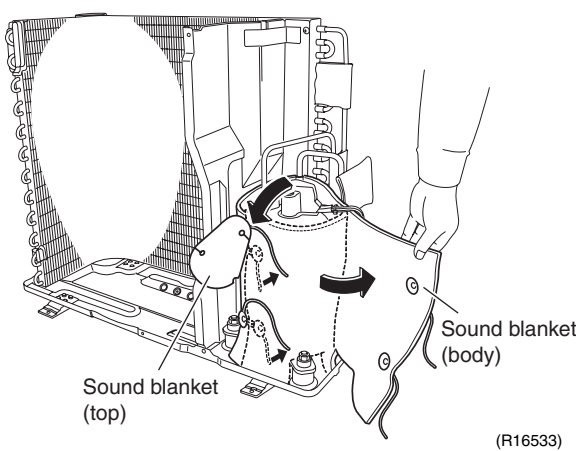

5. Capillary Tube



Warning

- ◆ Be sure to wait for 10 minutes or more after turning off all power supplies before disassembling work.
- ◆ Be careful not to get yourself burnt with the pipes and other parts that are heated by the gas brazing machine.
- ◆ If the refrigerant gas leaks during work, ventilate the room. (If the refrigerant gas is exposed to flames, toxic gas may be generated.)



Caution

- ◆ From the viewpoint of global environment protection, do not discharge the refrigerant gas in the atmosphere. Make sure to collect all the refrigerant gas.
- ◆ Restore the piping by non-oxidation brazing.



Note

- ◆ Before working, make sure that the refrigerant gas is empty in the circuit.
- ◆ Be sure to apply nitrogen replacement when heating up the brazed part.
- ◆ Do not use a metal saw for cutting pipes by all means because the sawdust comes into the circuit.
- ◆ When withdrawing the pipes, be careful not to pinch them firmly with pliers. The pipes may get deformed.
- ◆ Provide a protective sheet or a steel plate so that the brazing flame cannot influence peripheries.
- ◆ Be careful so as not to burn the compressor terminals, the name plate, the outdoor heat exchanger fin.
- ◆ In case of difficulty with gas brazing machine
 1. Disconnect the brazed part where is easy to disconnect and restore.
 2. Cut pipes on the main unit with a tube cutter in order to make it easy to disconnect.

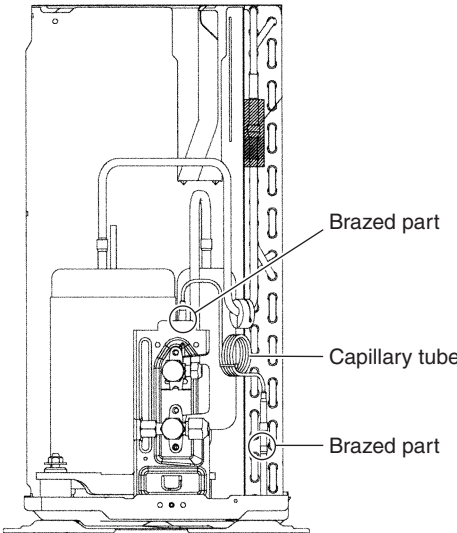
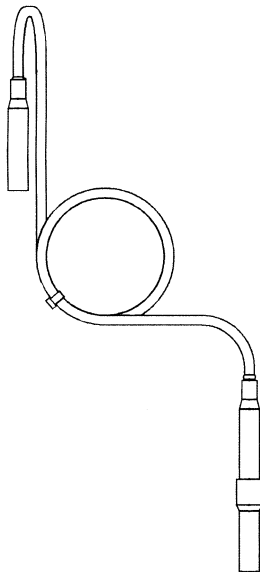
Step	Procedure	Points
<p>1</p>	<p>Remove the putty. Heat up the 2 brazed parts and remove the capillary tube.</p> 	 <p>■ The shape of the capillary tube varies depending on the model.</p>

6. Compressor ASSY



Warning

- ◆ Be sure to wait for 10 minutes or more after turning off all power supplies before disassembling work.
- ◆ Be careful not to get yourself burnt with the pipes and other parts that are heated by the gas brazing machine.
- ◆ If the refrigerant gas leaks during work, ventilate the room. (If the refrigerant gas is exposed to flames, toxic gas may be generated.)
- ◆ Since it may happen that the refrigerant oil in the compressor catches fire, prepare wet cloth so as to extinguish fire immediately.



Caution

- ◆ From the viewpoint of global environment protection, do not discharge the refrigerant gas in the atmosphere. Make sure to collect all the refrigerant gas.
- ◆ Restore the piping by non-oxidation brazing.



Note

- ◆ Before working, make sure that the refrigerant gas is empty in the circuit.
- ◆ Be sure to apply nitrogen replacement when heating up the brazed part.
- ◆ Do not use a metal saw for cutting pipes by all means because the sawdust comes into the circuit.
- ◆ When withdrawing the pipes, be careful not to pinch them firmly with pliers. The pipes may get deformed.
- ◆ Provide a protective sheet or a steel plate so that the brazing flame cannot influence peripheries.
- ◆ Be careful so as not to burn the compressor terminals, the name plate, the outdoor heat exchanger fin.
- ◆ In case of difficulty with gas brazing machine
 1. Disconnect the brazed part where is easy to disconnect and restore.
 2. Cut pipes on the main unit with a tube cutter in order to make it easy to disconnect.

Step	Procedure	Points
1	Remove the nut on the terminal cover.	<div data-bbox="486 1205 1075 1675" data-label="Image"> </div> <div data-bbox="1086 1196 1461 2107"> <ul style="list-style-type: none"> ■ The shape of the terminal cover varies depending on the model. </div>

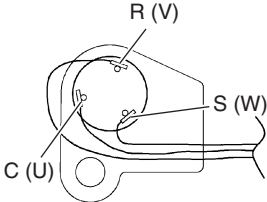
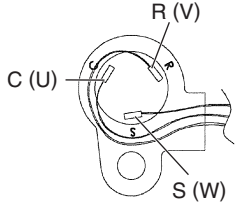
Step	Procedure	Points
2	Remove the terminal cover.	
3	Disconnect the compressor lead wires.	<p>■ Compressor lead wire For R-410A models</p>  <p>(R15375)</p> <p>For R-32 models</p>  <p>(R20742)</p> <p>S (W): yellow C (U): blue R (V): red</p>
4	Remove the 3 nuts of the compressor.	

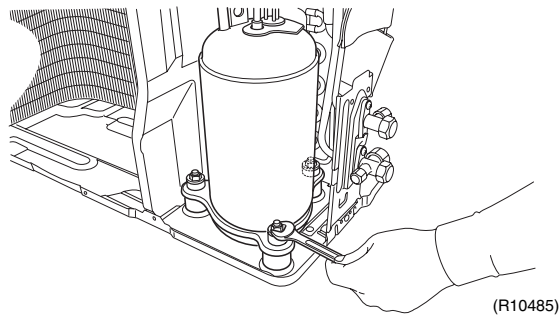
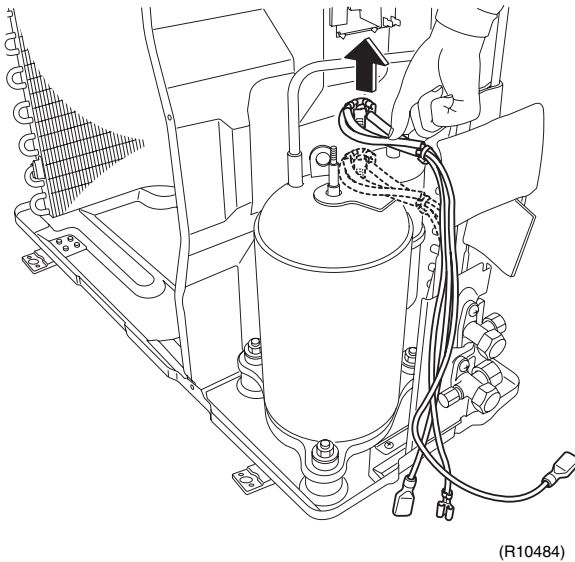
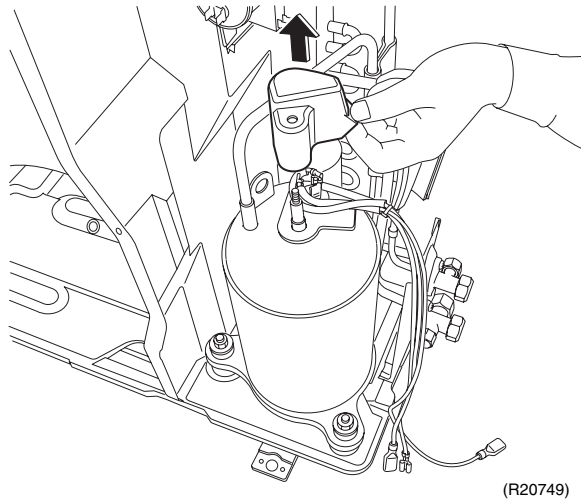

Step	Procedure	Points
5	Heat up the brazed part of the discharge side pipe and disconnect it.	
6	Heat up the brazed part of the suction side pipe and disconnect it.	
7	Lift the compressor ASSY up and remove it.	

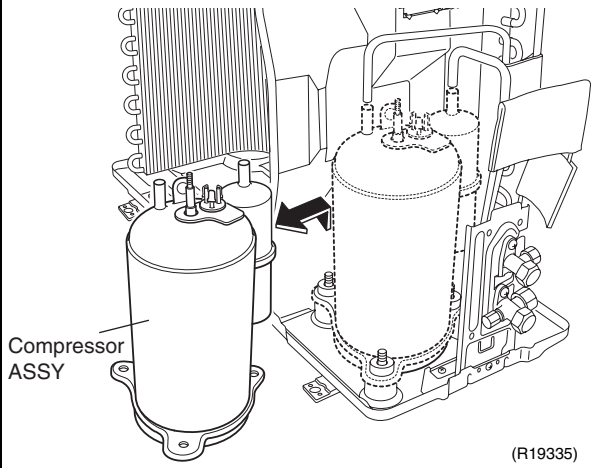
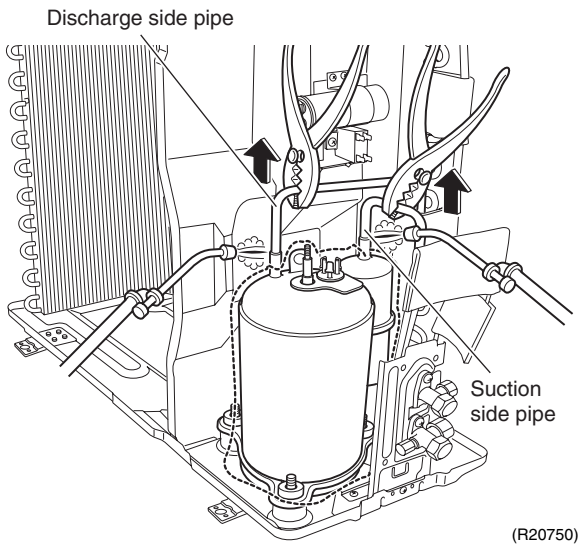

Revision History

Month / Year	Version	Revised contents
08 / 2013	Si011356E	First edition
09 / 2014	Si011356EA	Model addition: ARM09MV2S, RM09NV2S, RM25JV14, RM25KV1V

Warning



- Daikin products are manufactured for export to numerous countries throughout the world. Prior to purchase, please confirm with your local authorised importer, distributor and/or retailer whether this product conforms to the applicable standards, and is suitable for use, in the region where the product will be used. This statement does not purport to exclude, restrict or modify the application of any local legislation.
- Ask a qualified installer or contractor to install this product. Do not try to install the product yourself. Improper installation can result in water or refrigerant leakage, electrical shock, fire or explosion.
- Use only those parts and accessories supplied or specified by Daikin. Ask a qualified installer or contractor to install those parts and accessories. Use of unauthorised parts and accessories or improper installation of parts and accessories can result in water or refrigerant leakage, electrical shock, fire or explosion.
- Read the user's manual carefully before using this product. The user's manual provides important safety instructions and warnings. Be sure to follow these instructions and warnings.

If you have any enquiries, please contact your local importer, distributor and/or retailer.

Cautions on product corrosion

1. Air conditioners should not be installed in areas where corrosive gases, such as acid gas or alkaline gas, are produced.
2. If the outdoor unit is to be installed close to the sea shore, direct exposure to the sea breeze should be avoided. If you need to install the outdoor unit close to the sea shore, contact your local distributor.

Dealer

DAIKIN INDUSTRIES, LTD.

Head Office:
Umeda Center Bldg., 2-4-12, Nakazaki-Nishi,
Kita-ku, Osaka, 530-8323 Japan

Tokyo Office:
JR Shinagawa East Bldg., 2-18-1, Konan,
Minato-ku, Tokyo, 108-0075 Japan

<http://www.daikin.com/products/ac/>

©All rights reserved