



# REMOVAL PROCEDURE



## S E R V I C E M A N U A L

### 1.5/2.0/2.5 kW Class

-  Outdoor Unit
-  Non-Inverter
-  Pair Type

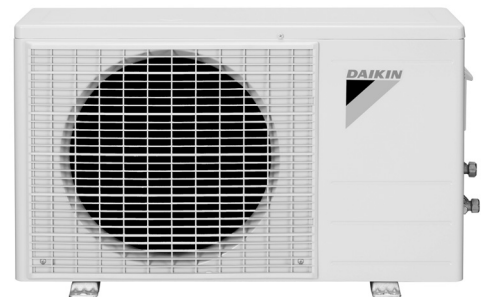

# **Service Manual Removal Procedure**

## **Outdoor Unit**

### **●Cooling Only**

**R15LV14  
R20LV14  
R25LV14**

**RE15LV1  
RE20LV1  
RE25LV1**

**RE20MV1V  
RE25MV1V**

**RNE25LV1**

**RNE15MV1  
RNE20MV1  
RNE25MV1**

**RNE15MV14  
RNE20MV14  
RNE25MV14**

**RNE20MV1V9  
RNE25MV1V9**

# Table of Contents

1. Outer Panels .....	2
2. Outdoor Fan / Fan Motor.....	3
3. Electrical Components .....	5
4. Capillary Tube .....	9
5. Compressor ASSY .....	10



**Note:** ♦ The illustrations may be slightly different depending on the model.

# 1. Outer Panels



**Warning**

◆ Be sure to wait for 10 minutes or more after turning off all power supplies before disassembling work.

Step	Procedure	Points
1	Remove the 4 screws and remove the top panel.	<ul style="list-style-type: none"> <li>■ Some models have only 1 screw on the left side of the top panel.</li> </ul>
2	Remove the 2 screws of the discharge grille.	
3	Unfasten the 6 hooks and remove the discharge grille.	
4	Remove the 5 screws of the front panel.	
5	Unfasten the 4 hooks and remove the front panel.	

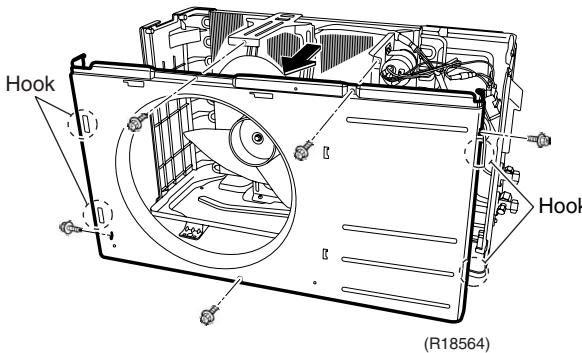
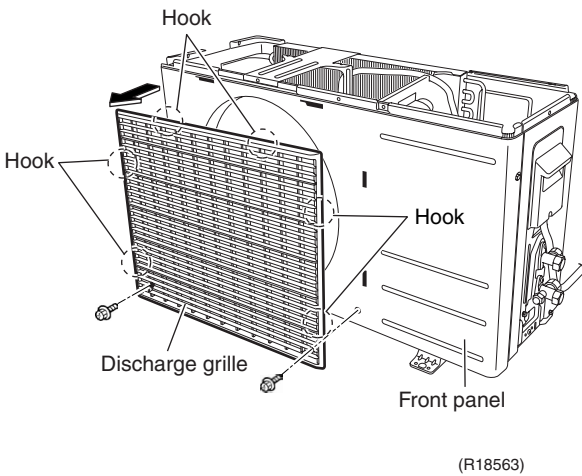
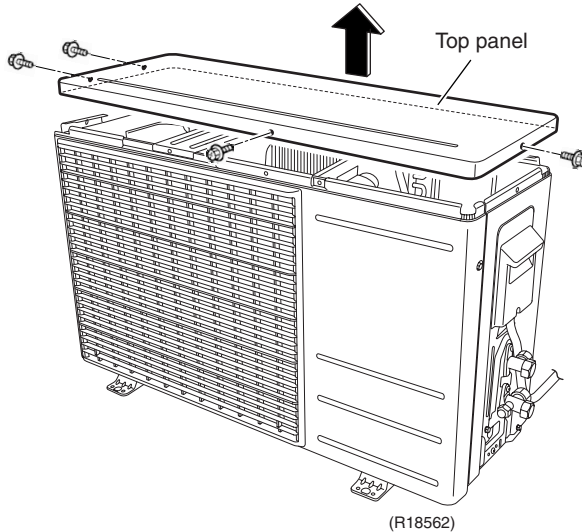

## 2. Outdoor Fan / Fan Motor



**Warning**

◆ Be sure to wait for 10 minutes or more after turning off all power supplies before disassembling work.

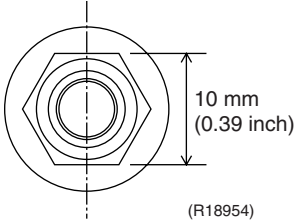
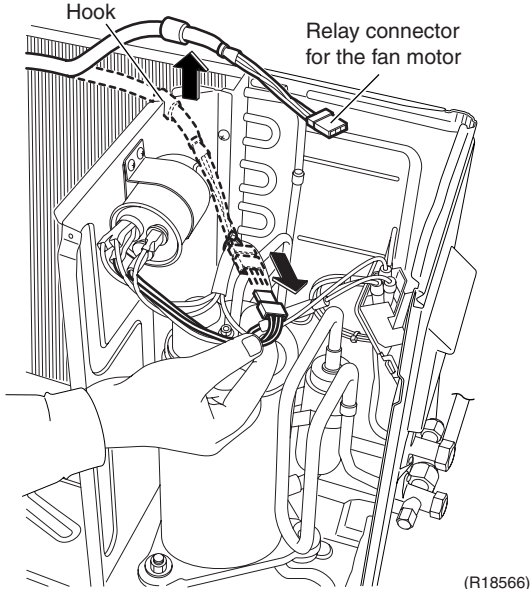
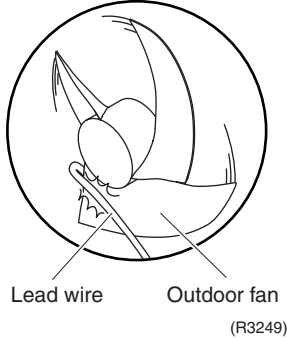
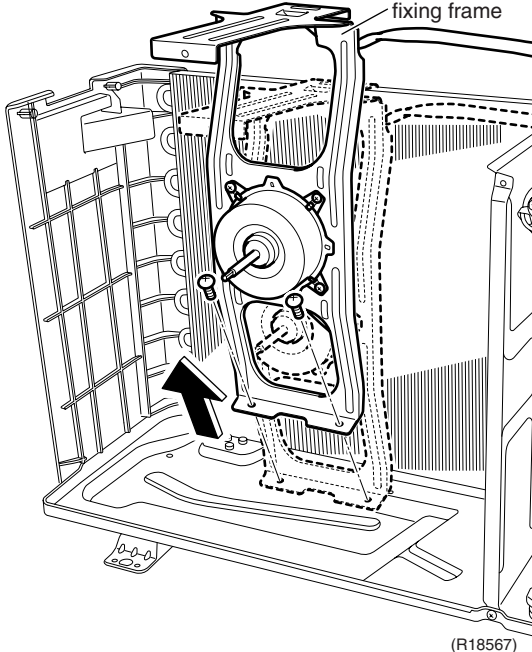
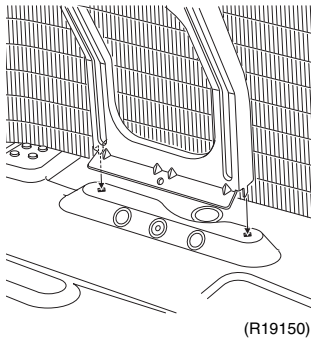
Step	Procedure	Points
1	Remove the nut and remove the outdoor fan.	<p>■ Nut size: M6</p>  <p>■ When reassembling, align the ▼ mark of the outdoor fan with the D-cut section of the motor shaft.</p>
2	Disconnect the relay connector for the fan motor.	<p>■ When reassembling, put the fan motor lead wire through the back of the fan motor so as not to be entangled with the outdoor fan.</p>
3	Release the fan motor lead wire from the hook.	 
4	Remove the 2 screws and remove the fan motor fixing frame.	<p>■ When reassembling, fit the lower hooks into the bottom frame.</p>  

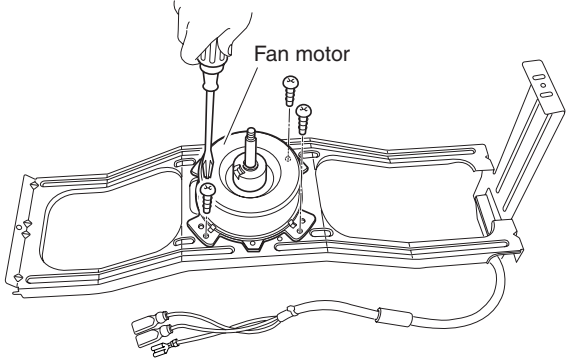
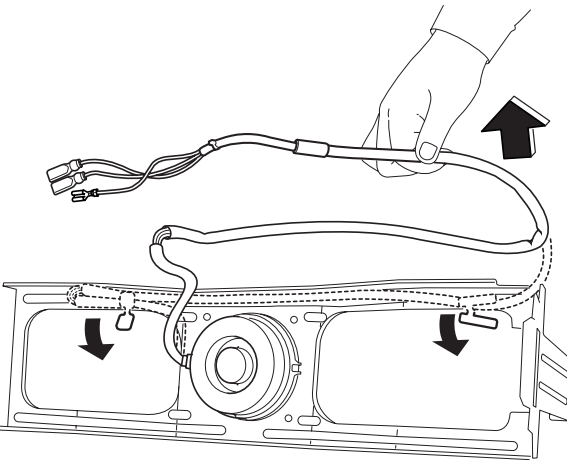
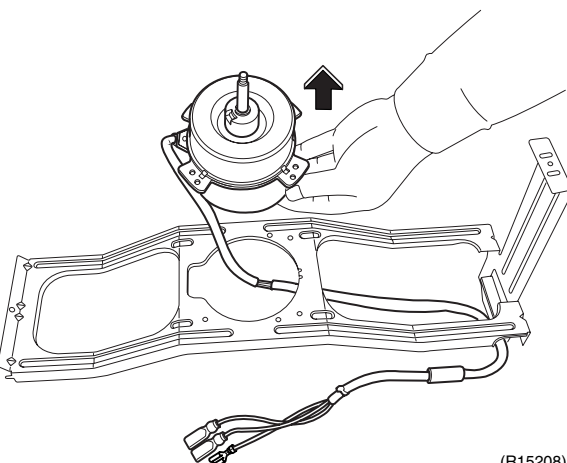
Step	Procedure	Points	Points
5	Remove the 3 screws.	 <p style="text-align: center;">(R10461)</p>	
6	Release the fan motor lead wire from the 2 hooks.	 <p style="text-align: center;">(R15207)</p>	
7	Remove the fan motor.	 <p style="text-align: center;">(R15208)</p>	

### 3. Electrical Components



**Warning**

◆ Be sure to wait for 10 minutes or more after turning off all power supplies before disassembling work.

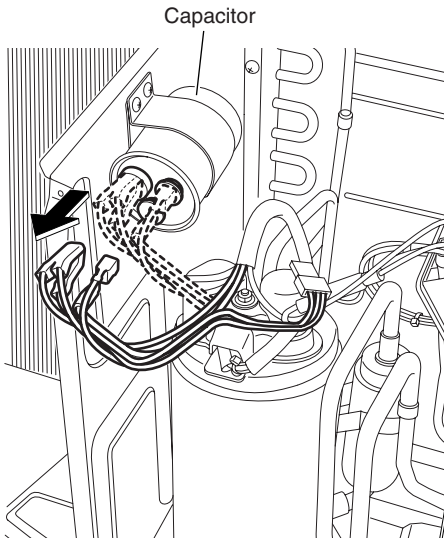
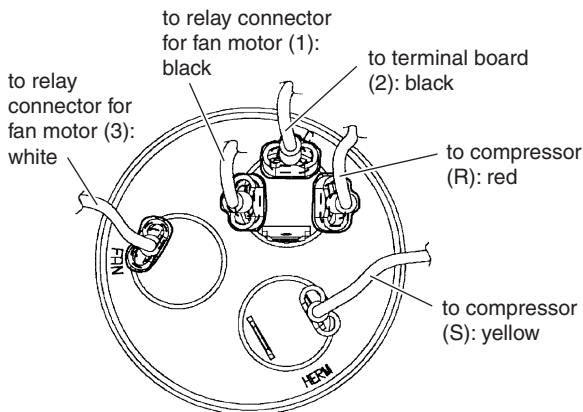
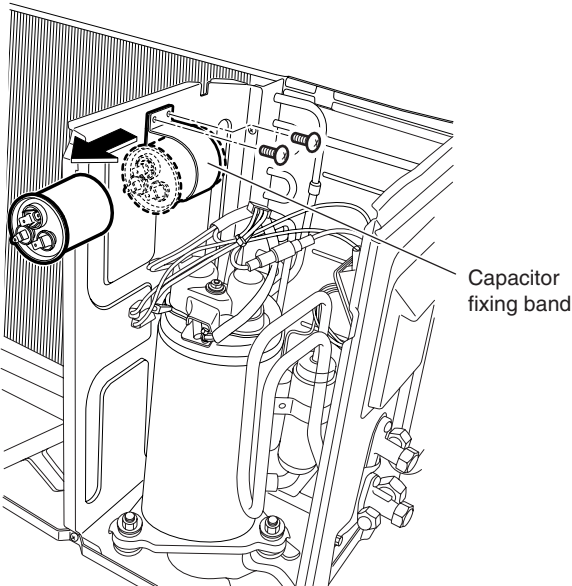
Step	Procedure	Points
1	<p>Pull out the 5 terminals from the capacitor.</p>  <p style="text-align: right;">(R18568)</p>  <p style="text-align: right;">(R19170)</p>	
2	<p>Loosen the 2 screws of the capacitor fixing band and remove the capacitor.</p>  <p style="text-align: right;">(R18569)</p>	

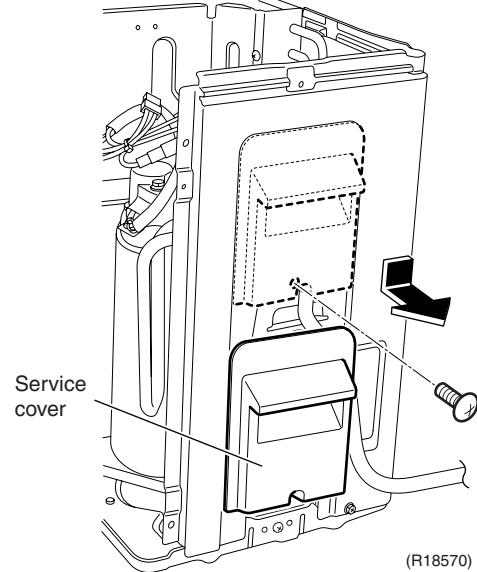
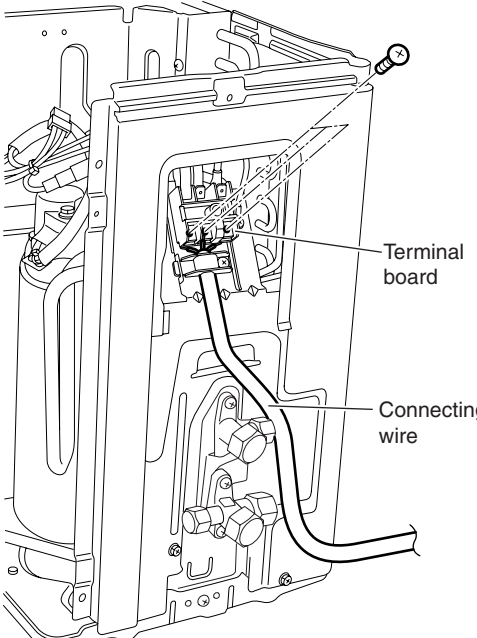
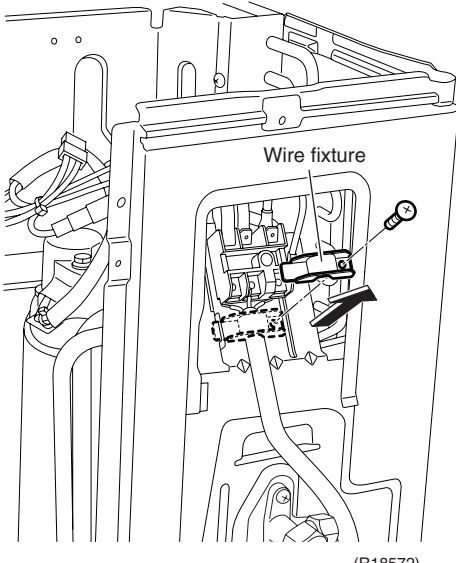
Step	Procedure	Points
3	<p>Remove the screw and remove the service cover sliding downward.</p> 	
4	<p>Remove the 3 screws on the terminal board and disconnect the connecting wire.</p> 	
5	<p>Remove the screw and remove the wire fixture.</p> 	

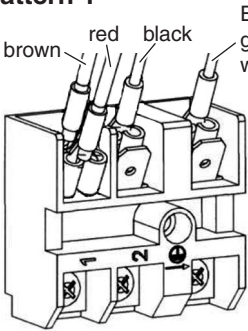
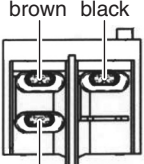

Step	Procedure	Points
6	Remove the screw and detach the earth / ground wire.	<ul style="list-style-type: none"> <li>Some models have no earth / ground wire. When reassembling, confirm the terminal location.</li> </ul>
7	Pull out the remaining terminals from the terminal board.	<p><b>Pattern 1</b></p>  <p>(R21471)</p> <p><b>Pattern 2</b></p>  <p>(R21472)</p>
8	Remove the screw and remove the terminal board.	

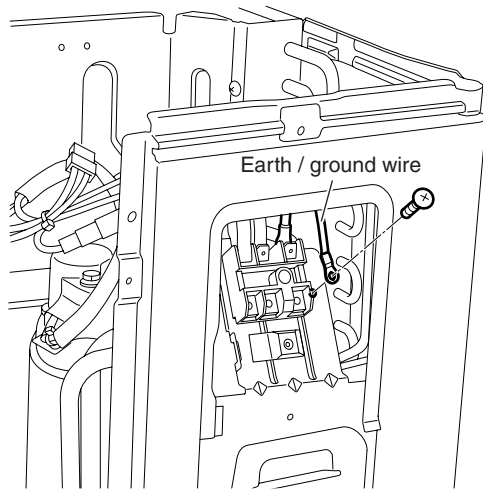

(R18573)

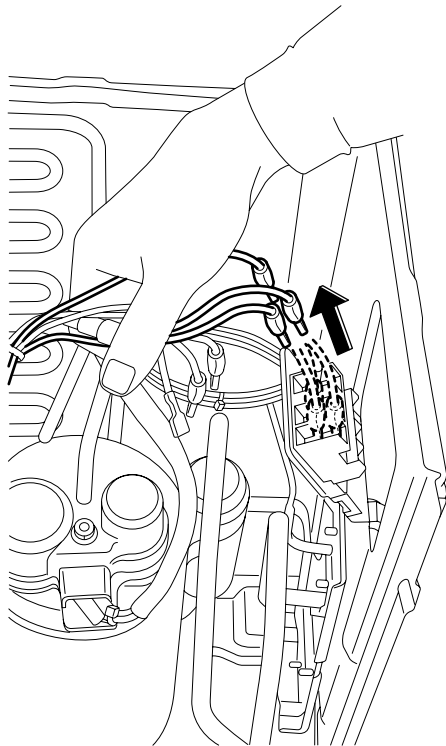

(R18574)

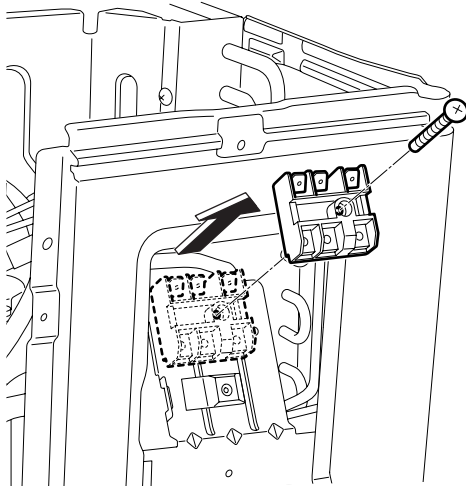

(R18575)

Step	Procedure	Points
9	When replacing the fuse, open the fuse holder.	<ul style="list-style-type: none"> <li>Some models do not have a fuse.</li> </ul>
10	Remove the 4 screws and remove the right side panel.	<ul style="list-style-type: none"> <li>When reassembling, fit the lower hook of the bottom frame into the hole of the partition plate.</li> </ul>
11	Remove the 2 screws and remove the partition plate.	

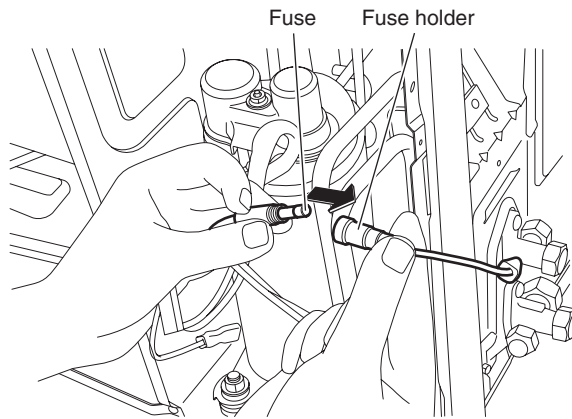

(R18576)

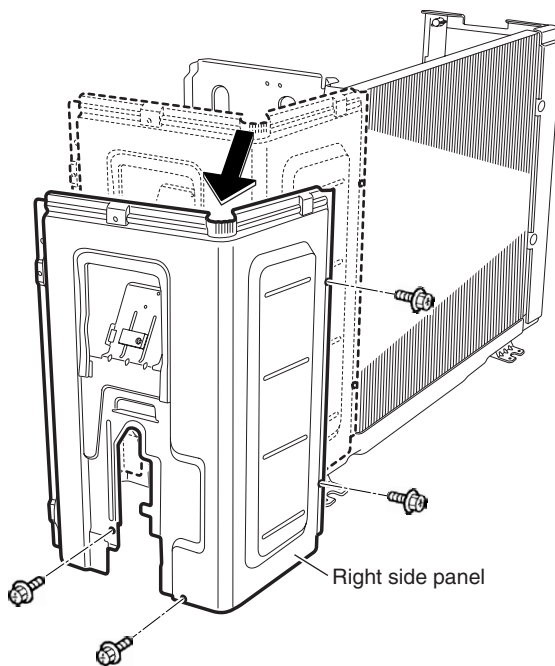

(R19563)

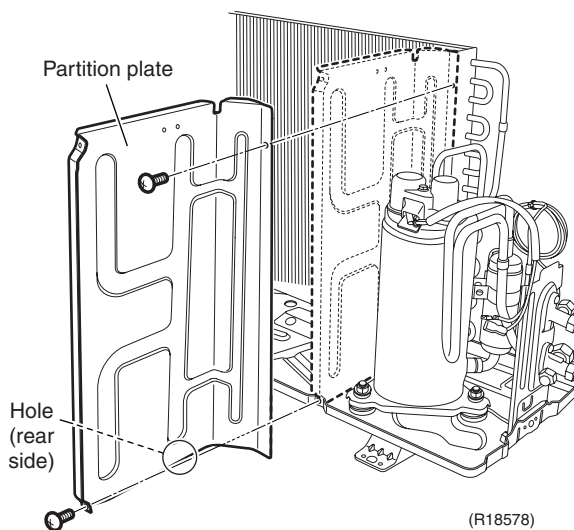

(R18578)

## 4. Capillary Tube



### Warning

- ◆ Be sure to wait for 10 minutes or more after turning off all power supplies before disassembling work.
- ◆ Be careful not to get yourself burnt with the pipes and other parts that are heated by the gas brazing machine.
- ◆ If the refrigerant gas leaks during work, ventilate the room. (If the refrigerant gas is exposed to flames, toxic gas may be generated.)



### Caution

- ◆ From the viewpoint of global environment protection, do not discharge the refrigerant gas in the atmosphere. Make sure to collect all the refrigerant gas.
- ◆ Restore the piping by non-oxidation brazing.



### Note

- ◆ Before working, make sure that the refrigerant gas is empty in the circuit.
- ◆ Be sure to apply nitrogen replacement when heating up the brazed part.
- ◆ Do not use a metal saw for cutting pipes by all means because the sawdust comes into the circuit.
- ◆ When withdrawing the pipes, be careful not to pinch them firmly with pliers. The pipes may get deformed.
- ◆ Provide a protective sheet or a steel plate so that the brazing flame cannot influence peripheries.
- ◆ Be careful so as not to burn the compressor terminals, the name plate, the outdoor heat exchanger fin.
- ◆ In case of difficulty with gas brazing machine
  1. Disconnect the brazed part where is easy to disconnect and restore.
  2. Cut pipes on the main unit with a tube cutter in order to make it easy to disconnect.

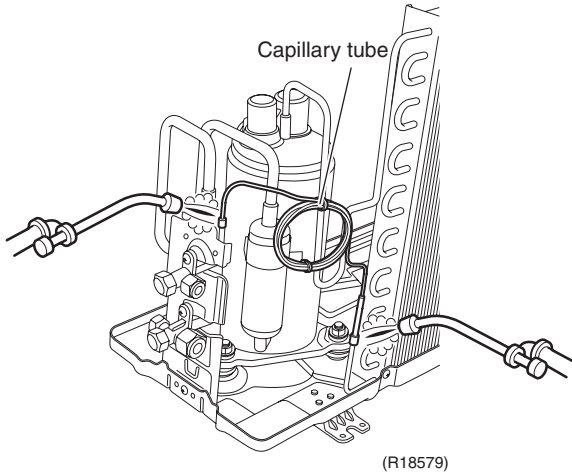
Step	Procedure	Points
1	Heat up the 2 brazed parts and remove the capillary tube. <div style="text-align: center;">  <p>(R18579)</p> </div>	<ul style="list-style-type: none"> <li>■ The design of the capillary tube varies depending on the model.</li> </ul>

## 5. Compressor ASSY



### Warning

- ◆ Be sure to wait for 10 minutes or more after turning off all power supplies before disassembling work.
- ◆ Be careful not to get yourself burnt with the pipes and other parts that are heated by the gas brazing machine.
- ◆ If the refrigerant gas leaks during work, ventilate the room. (If the refrigerant gas is exposed to flames, toxic gas may be generated.)
- ◆ Since it may happen that the refrigerant oil in the compressor catches fire, prepare wet cloth so as to extinguish fire immediately.



### Caution

- ◆ From the viewpoint of global environment protection, do not discharge the refrigerant gas in the atmosphere. Make sure to collect all the refrigerant gas.
- ◆ Restore the piping by non-oxidation brazing.



### Note

- ◆ Before working, make sure that the refrigerant gas is empty in the circuit.
- ◆ Be sure to apply nitrogen replacement when heating up the brazed part.
- ◆ Do not use a metal saw for cutting pipes by all means because the sawdust comes into the circuit.
- ◆ When withdrawing the pipes, be careful not to pinch them firmly with pliers. The pipes may get deformed.
- ◆ Provide a protective sheet or a steel plate so that the brazing flame cannot influence peripheries.
- ◆ Be careful so as not to burn the compressor terminals, the name plate, the outdoor heat exchanger fin.
- ◆ In case of difficulty with gas brazing machine
  1. Disconnect the brazed part where is easy to disconnect and restore.
  2. Cut pipes on the main unit with a tube cutter in order to make it easy to disconnect.

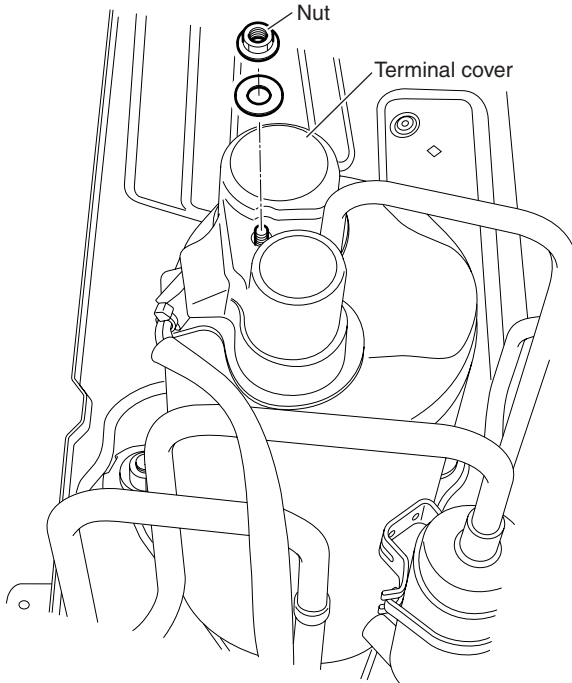
Step	Procedure	Diagram	Points
1	Remove the nut.	 <p style="text-align: center;">(R18580)</p>	
2	Remove the terminal cover.		

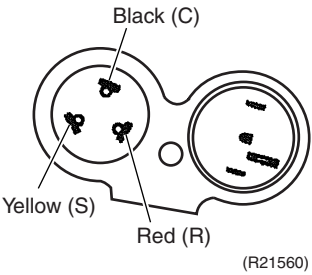
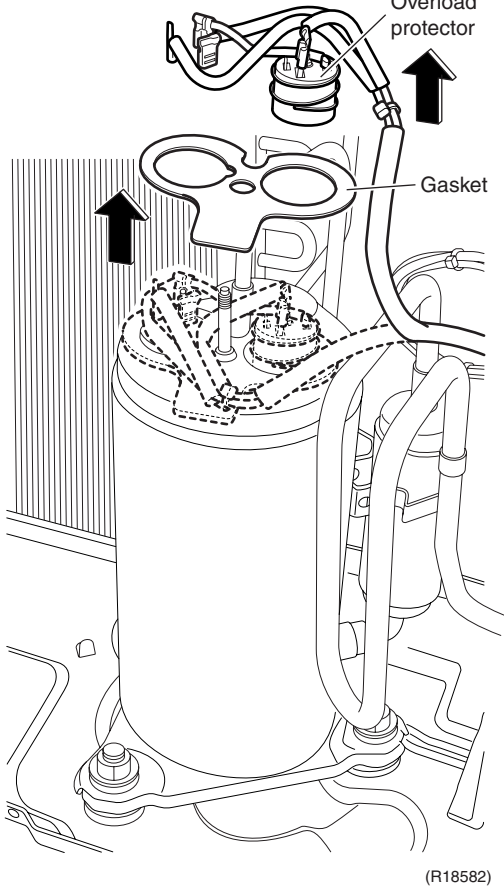
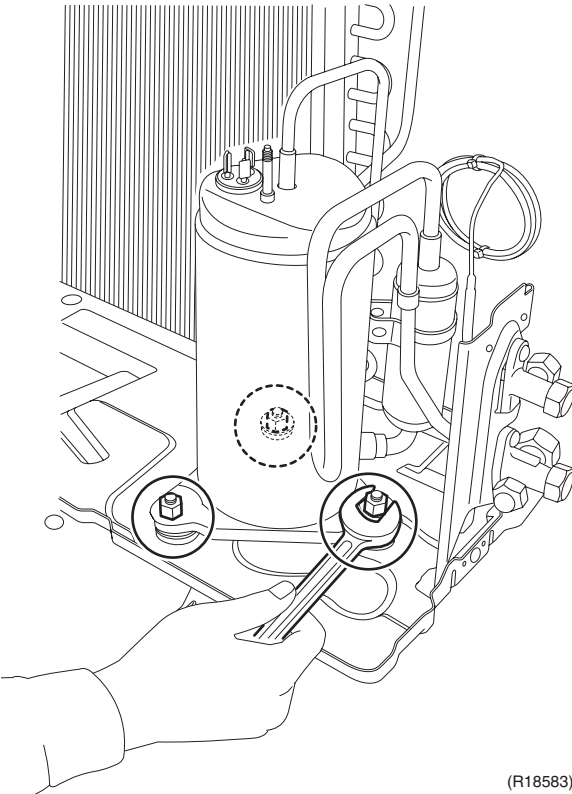
Step	Procedure	Points
3	Disconnect the compressor lead wires and remove the overload protector.	 <p>Black (C) Yellow (S) Red (R) (R21560)</p>
4	Remove the gasket.	 <p>Overload protector Gasket (R18582)</p>
5	Remove the 3 nuts of the compressor.	 <p>(R18583)</p>

Step	Procedure	Points
6	Heat up the 2 brazed parts and disconnect them.	<ul style="list-style-type: none"> <li>■ Before heating up, make sure to remove the sheets of putty so as not to burn them.</li> </ul>
7	Lift up the compressor and remove it.	

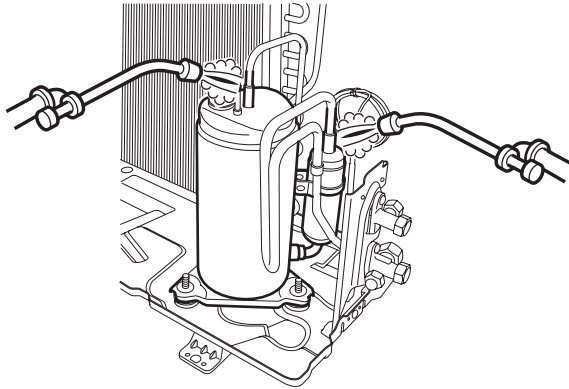

(R18584)

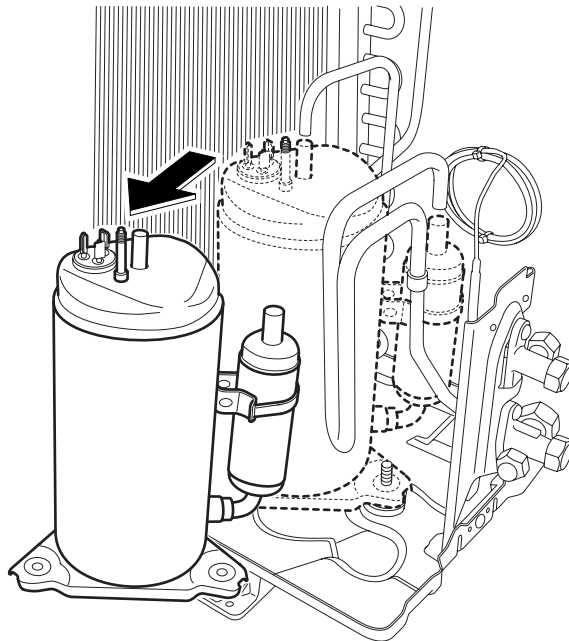

(R18585)

# Revision History

Month / Year	Version	Revised contents
06 / 2013	Si011282E	First edition
12 / 2013	Si011282EA	Model addition: RE15/20/25LV1, RE20/25MV1V
03 / 2015	Si011282EB	Model addition: RNE25LV1, RNE15/20/25MV1, RNE15/20/25MV14, RNE20/25MV1V9

Warning



- Daikin products are manufactured for export to numerous countries throughout the world. Prior to purchase, please confirm with your local authorised importer, distributor and/or retailer whether this product conforms to the applicable standards, and is suitable for use, in the region where the product will be used. This statement does not purport to exclude, restrict or modify the application of any local legislation.
- Ask a qualified installer or contractor to install this product. Do not try to install the product yourself. Improper installation can result in water or refrigerant leakage, electrical shock, fire or explosion.
- Use only those parts and accessories supplied or specified by Daikin. Ask a qualified installer or contractor to install those parts and accessories. Use of unauthorised parts and accessories or improper installation of parts and accessories can result in water or refrigerant leakage, electrical shock, fire or explosion.
- Read the user's manual carefully before using this product. The user's manual provides important safety instructions and warnings. Be sure to follow these instructions and warnings.

If you have any enquiries, please contact your local importer, distributor and/or retailer.

### Cautions on product corrosion

1. Air conditioners should not be installed in areas where corrosive gases, such as acid gas or alkaline gas, are produced.
2. If the outdoor unit is to be installed close to the sea shore, direct exposure to the sea breeze should be avoided. If you need to install the outdoor unit close to the sea shore, contact your local distributor.

### Dealer

### **DAIKIN INDUSTRIES, LTD.**

Head Office:  
Umeda Center Bldg., 2-4-12, Nakazaki-Nishi,  
Kita-ku, Osaka, 530-8323 Japan

Tokyo Office:  
JR Shinagawa East Bldg., 2-18-1, Konan,  
Minato-ku, Tokyo, 108-0075 Japan

<http://www.daikin.com/products/ac/>

©All rights reserved