



# REMOVAL PROCEDURE



## S E R V I C E M A N U A L

### 6.0 kW Class 24000 Btu/h Class

-  Outdoor Unit
-  Non-Inverter
-  Pair Type



# **Service Manual Removal Procedure**

## **Outdoor Unit**

### **Applicable Models**

#### **●Cooling Only**

**RE24MV2S**

**R60HV16**

**RN60HV1G**

# Table of Contents

1. Removal of Outer Panels .....	2
2. Removal of Outdoor Fan / Fan Motor .....	5
3. Removal of Electrical Component ASSY .....	7
4. Removal of Sound Blankets .....	11
5. Removal of Capillary Tube .....	12
6. Removal of Compressor ASSY (Pattern 1) .....	13
7. Removal of Compressor ASSY (Pattern 2) .....	15



**Note:**

- ◆ The illustrations may be slightly different depending on the model.

# 1. Removal of Outer Panels

**Procedure**



**Warning** Be sure to wait for 10 minutes or more after turning off all power supplies before disassembling work.

Step	Procedure	Points
1. Remove the top panel.	<p>Top panel</p> <p>(R5423)</p>	<ul style="list-style-type: none"> <li>■ Piping may be slightly different from the illustrations.</li> </ul>
1 Remove the 8 screws of the top panel.	<p>(R5424)</p>	<ul style="list-style-type: none"> <li>■ Take care not to cut your finger by the fins of the outdoor heat exchanger.</li> </ul>
2 Pull the suction grille to unfasten the hook.	<p>Suction grille</p> <p>(R5425)</p>	
3 Lift up and remove the top panel.	<p>(R5426)</p>	

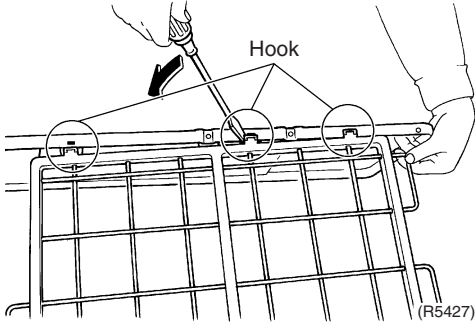
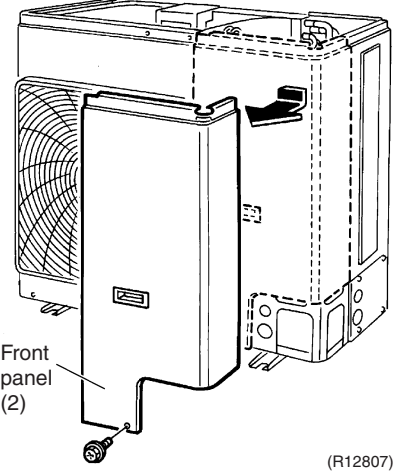
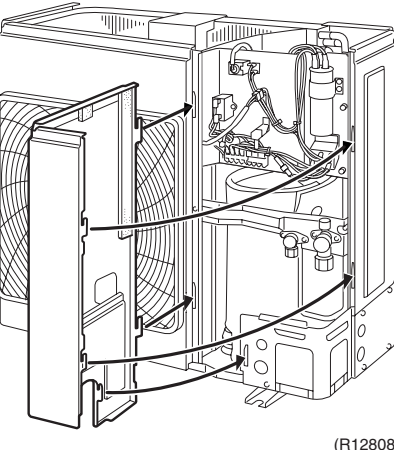
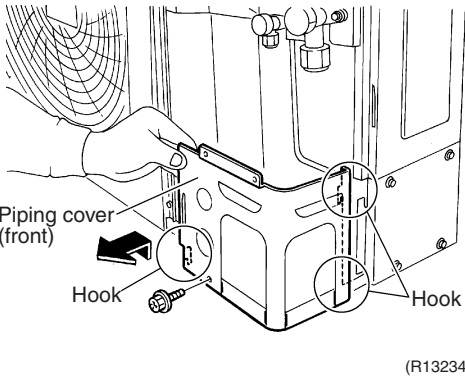
Step	Procedure	Points
4	Unfasten the hooks with a flat screwdriver and remove the suction grille.	
2. Remove the front panel (2).	 <p>(R5427)</p>	<p>■ When reassembling, fit the 5 hooks.</p>
1	Remove the screw and remove the front panel (2).	
3. Remove the piping cover (front).	 <p>Front panel (2)</p> <p>(R12807)</p>  <p>(R12808)</p>	
1	Remove the screw and remove the piping cover (front).	
	 <p>Piping cover (front)</p> <p>Hook</p> <p>Hook</p> <p>(R13234)</p>	

Step	Procedure	Points
4. Remove the front panel (1).	<p>Front panel (1)</p> <p>(R12810)</p> <p>(R5432)</p> <p>(R8322)</p>	

## 2. Removal of Outdoor Fan / Fan Motor

**Procedure**



**Warning** Be sure to wait for 10 minutes or more after turning off all power supplies before disassembling work.

Step	Procedure	Points
1	Disconnect the relay connector for the fan motor.	<p><b>Preparation</b></p> <ul style="list-style-type: none"> <li>Remove the front panel according to the "Removal of Outer Panels".</li> </ul>
2	Unfasten the hook with a flat screwdriver.	<ul style="list-style-type: none"> <li>Put the fan motor lead wire through the back of the fan motor when reassembling so as not to be entangled with the outdoor fan.</li> </ul>
3	Release the fan motor lead wire from the partition plate.	<p>Lead wire      Outdoor fan (R3249)</p>

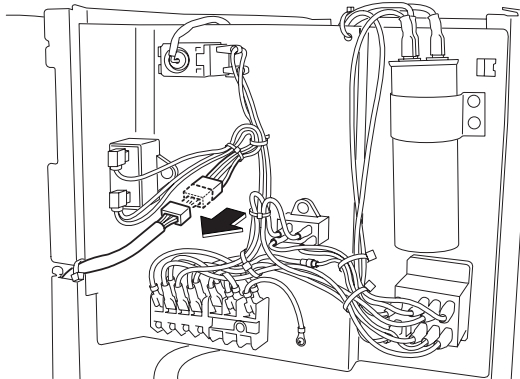

(R15492)

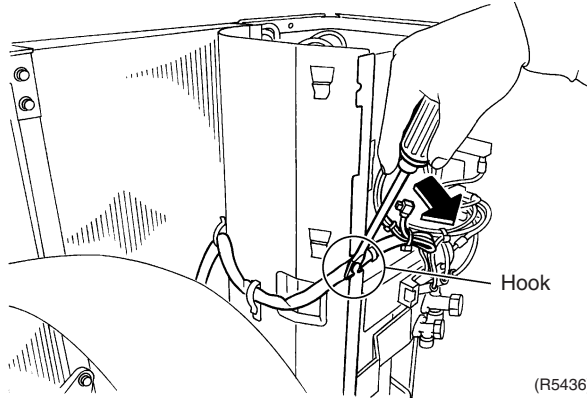

(R5436)

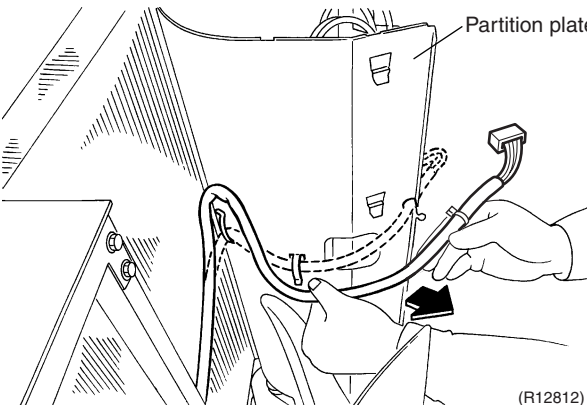

(R12812)

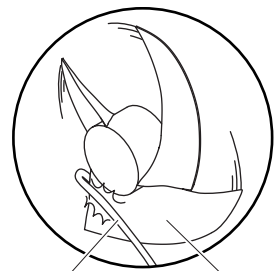

Lead wire      Outdoor fan  
(R3249)

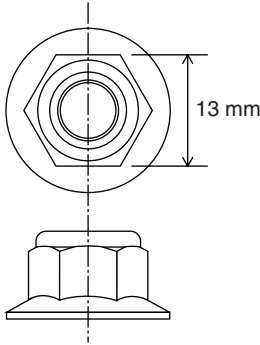
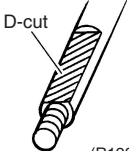
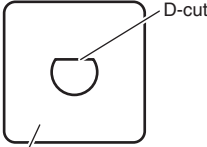
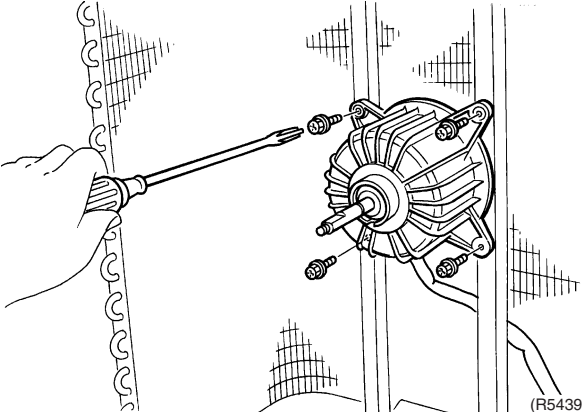
Step	Procedure	Points
4	Remove the nut and remove the outdoor fan.	<ul style="list-style-type: none"> <li>■ Nut size : M8</li> </ul>  <p style="text-align: right;">(R12301)</p> <ul style="list-style-type: none"> <li>■ When reassembling, fit the D-cuts of the lock washer and the shaft of fan motor.</li> </ul>  <p style="text-align: right;">(R12834)</p>  <p style="text-align: right;">(R12835)</p>
5	Remove the 4 screws and remove the fan motor.	 <p style="text-align: right;">(R5439)</p> <ul style="list-style-type: none"> <li>■ Be sure to remove the lower screws first. If the upper screws are removed first, the fan motor may tilt or fall because the center of its gravity is toward the front. It may cause injuries.</li> <li>■ M5 × 16</li> </ul>



### 3. Removal of Electrical Component ASSY

#### Procedure

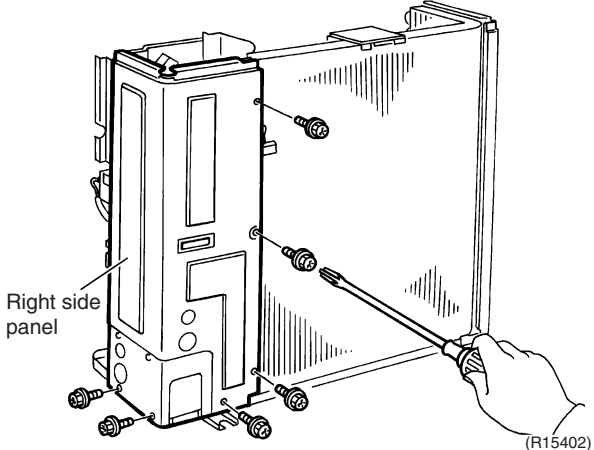
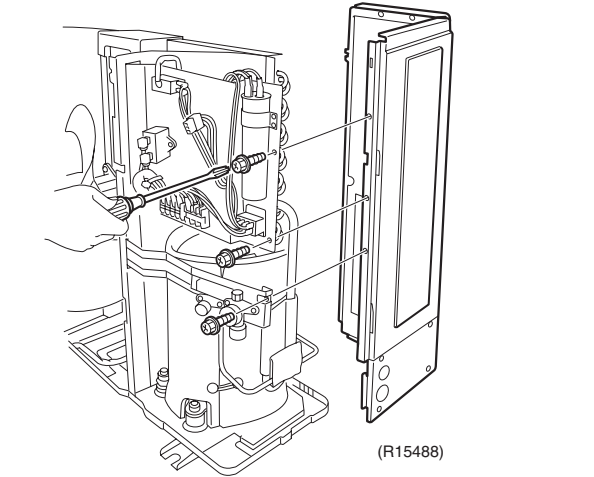
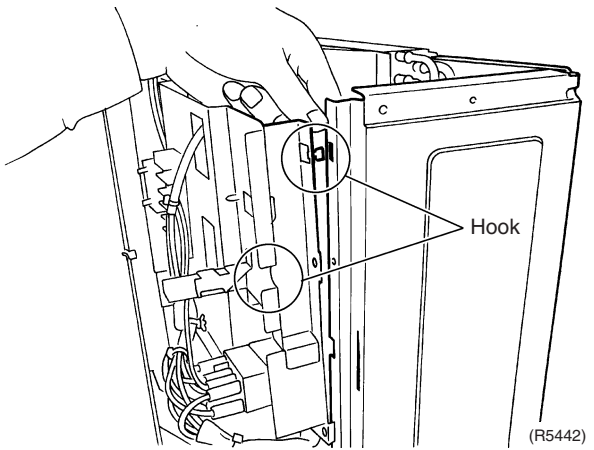

**Warning** Be sure to wait for 10 minutes or more after turning off all power supplies before disassembling work.

Step	Procedure	Points
1. Remove the side panel.	 <p>Right side panel</p> <p>(R15402)</p>  <p>(R15488)</p>  <p>Hook</p> <p>(R5442)</p>	<p><b>Preparation</b></p> <ul style="list-style-type: none"> <li>Remove the top panel, front panel (1) (2), and piping cover (front) according to the "Removal of Outer Panels".</li> </ul>

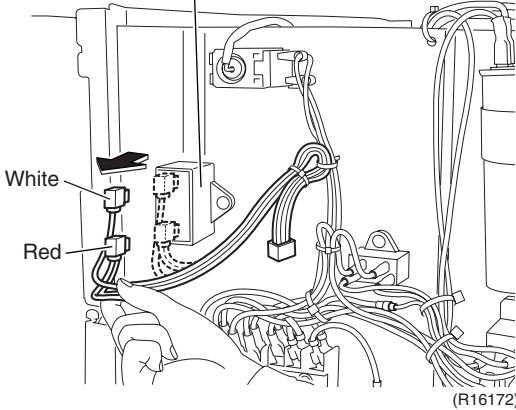
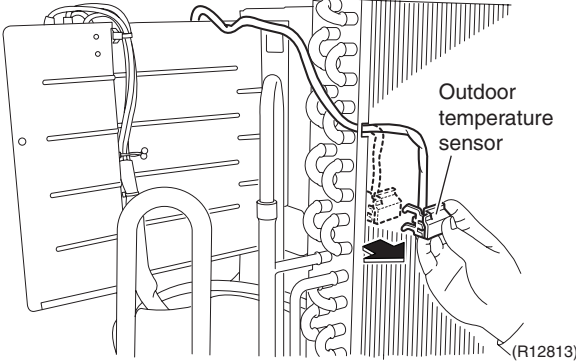
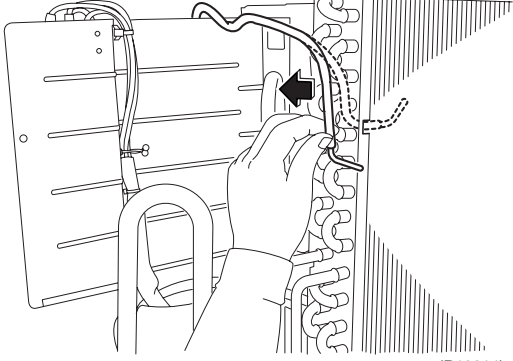
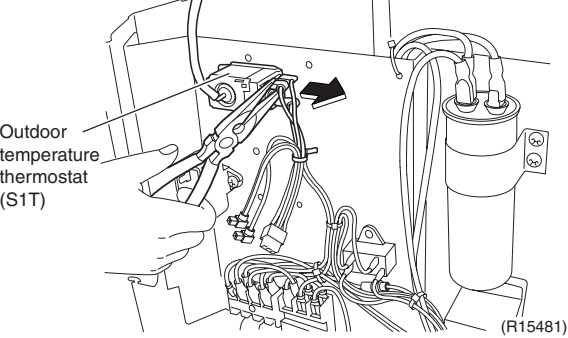
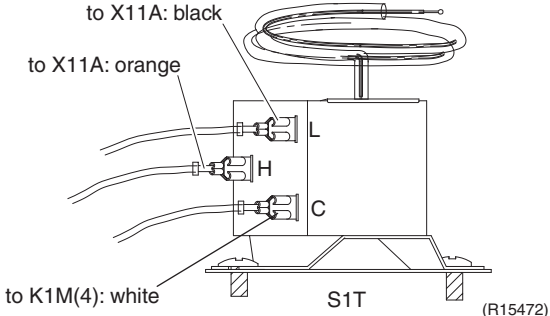
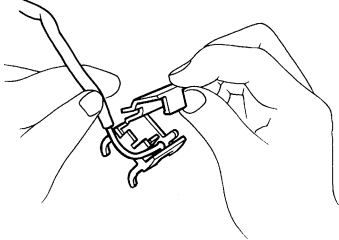
Step	Procedure	Points
2. Remove the electrical component ASSY.	<p data-bbox="628 226 895 255">Fan motor capacitor (C12R)</p>  <p data-bbox="970 651 1038 680">(R16172)</p> <p data-bbox="150 674 475 734">1 Disconnect the 2 terminals from the fan motor capacitor (C12R).</p> <p data-bbox="150 674 475 734">2 Detach the outdoor temperature sensor.</p>  <p data-bbox="932 770 1046 837">Outdoor temperature sensor</p> <p data-bbox="1002 1032 1070 1061">(R12813)</p>  <p data-bbox="963 1429 1032 1458">(R12814)</p> <p data-bbox="150 1458 475 1585">3 Disconnect the terminals of the outdoor temperature thermostat (S1T).</p>  <p data-bbox="491 1592 584 1682">Outdoor temperature thermostat (S1T)</p> <p data-bbox="991 1794 1059 1823">(R15481)</p>  <p data-bbox="584 1816 724 1845">to X11A: black</p> <p data-bbox="523 1868 679 1897">to X11A: orange</p> <p data-bbox="501 2101 657 2130">to K1M(4): white</p> <p data-bbox="826 2101 868 2130">S1T</p> <p data-bbox="979 2114 1048 2143">(R15472)</p>	 <p data-bbox="1094 994 1422 1055">■ Remove the sensor fixing plate.</p>

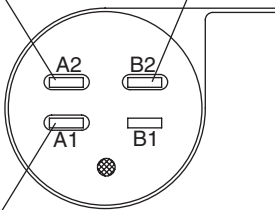
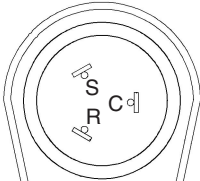
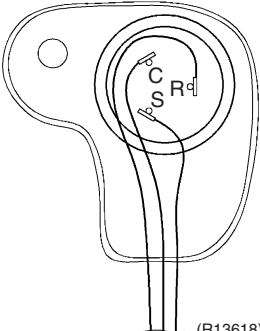
Step	Procedure	Points
4	Remove the screw and remove the outdoor temperature thermostat.	
5	Disconnect the terminals from the capacitor (C11R).	<p>■ Compressor capacitor (C11R)</p> <p>to compressor (R terminal) : red (S terminal) : yellow</p>  <p>to magnetic contactor K1M(6): red (R17612)</p>
6	Cut the 3 clamps.	<p>■ Compressor lead wire Pattern 1</p>  <p>(R12819)</p>
7	Disconnect the blue terminal: K1M (2).	<p>S : yellow C : blue R : red</p> <p>Pattern 2</p>  <p>(R13618)</p> <p>S : yellow C : blue R : red</p>

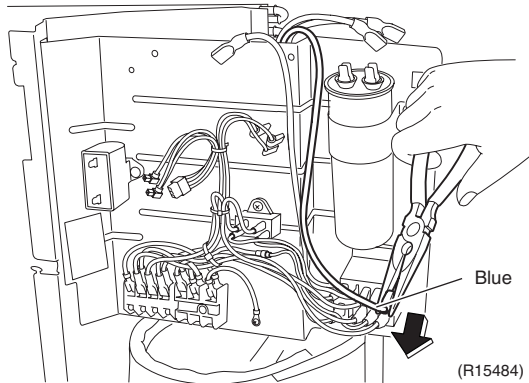
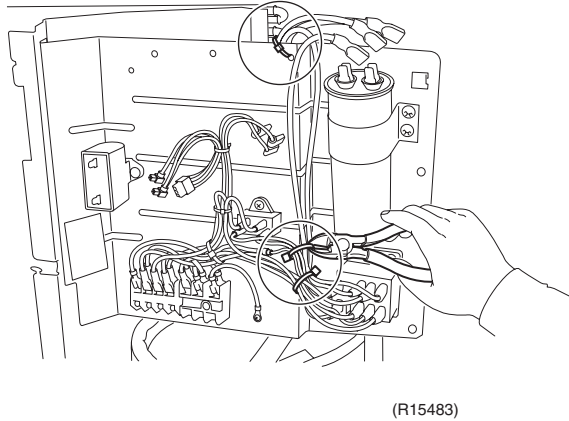
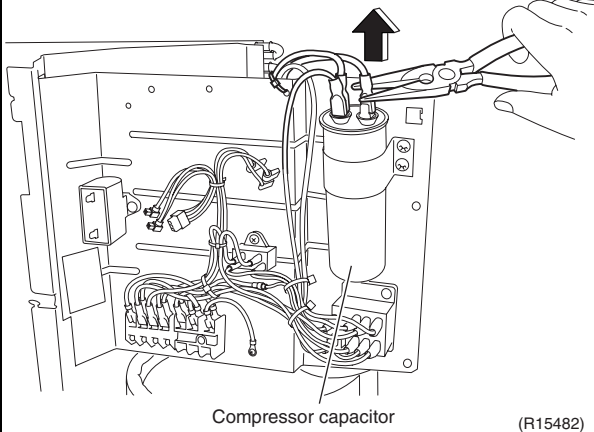
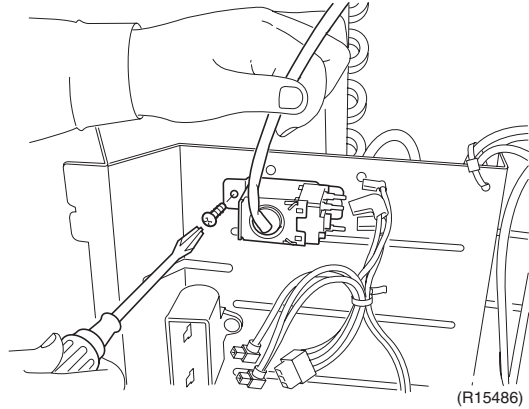

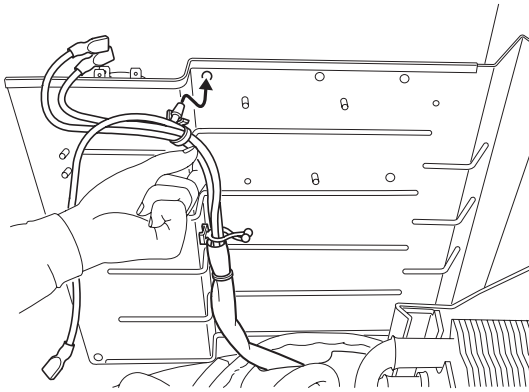
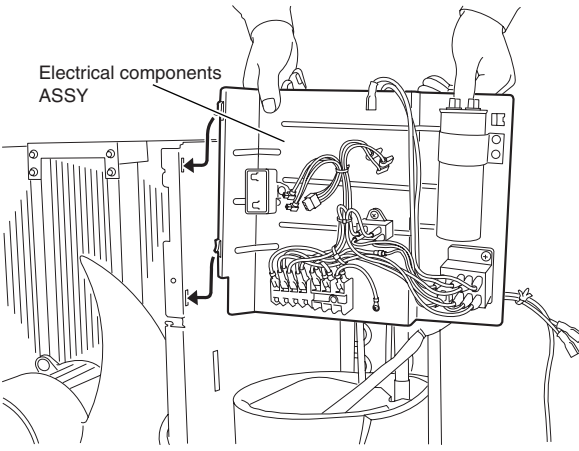
Step	Procedure	Points
8	Detach the clamp for the compressor lead wire (rear side).	
	 <p>(R6749)</p>	
9	Lift the electrical components ASSY to unfasten the 2 hooks and remove it.	
	 <p>Electrical components ASSY</p> <p>(R15485)</p>	

## 4. Removal of Sound Blankets

### Procedure

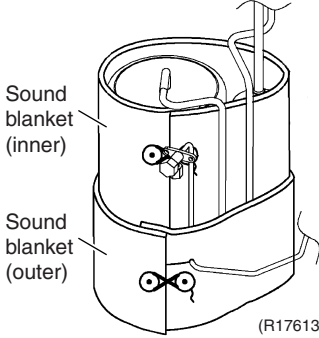

**Warning** Be sure to wait for 10 minutes or more after turning off all power supplies before disassembling work.

Step	Procedure	Points
1	Remove the sound blanket (top).	<p><b>Preparation</b></p> <ul style="list-style-type: none"> <li>■ Remove the electrical components ASSY according to the "Removal of Electrical Components ASSY".</li> <li>■ Since the piping ports on the sound blanket are torn easily, remove the blanket carefully.</li> </ul>
2	Remove the sound blanket (body).	<ul style="list-style-type: none"> <li>■ Some models have outer and inner sound blankets.</li> </ul> 

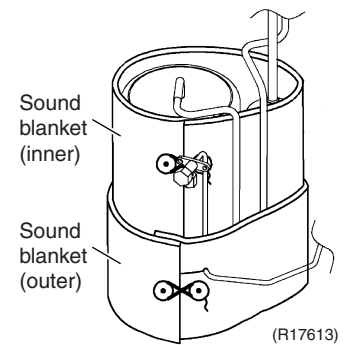
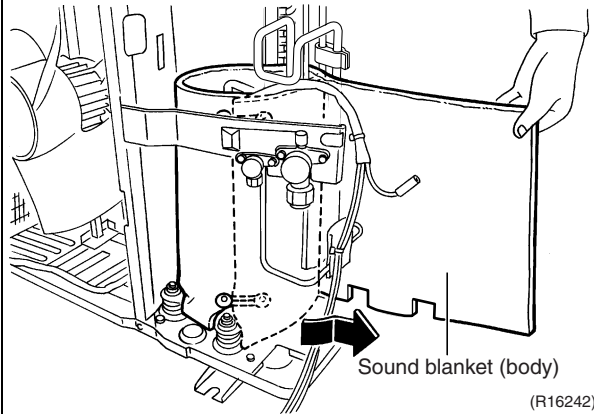
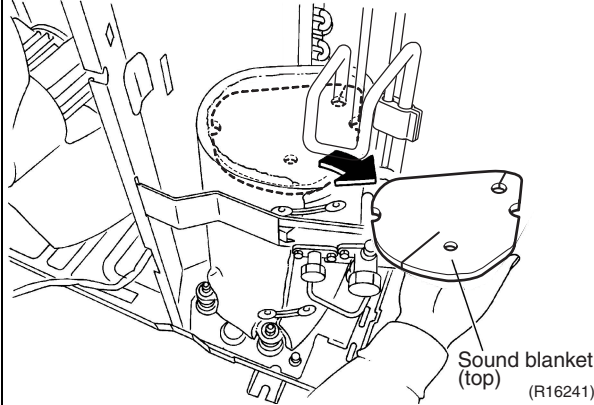

# 5. Removal of Capillary Tube

**Procedure**



**Warning** Be sure to wait for 10 minutes or more after turning off all power supplies before disassembling work.

Step	Procedure	Points
<ul style="list-style-type: none"> <li>■ Before working, make sure that the refrigerant gas is empty in the circuit.</li> <li>■ Be sure to apply nitrogen replacement when heating up the brazed part.</li> </ul>	<p style="text-align: right;">(R16175)</p>	<p><b>Warning</b> Be careful not to get yourself burnt with the pipes and other parts that are heated by the gas brazing machine.</p>
<p>1 Heat up the 2 brazed parts and remove the capillary tube.</p>	<p style="text-align: right;">(R16176)</p>	<p><b>Warning</b> If the refrigerant gas leaks during work, ventilate the room. (If the refrigerant gas is exposed to flames, toxic gas may be generated.)</p>
<p><b>Note:</b></p> <ul style="list-style-type: none"> <li>■ Do not use a metal saw for cutting pipes by all means because the sawdust comes into the circuit.</li> <li>■ When withdrawing the pipes, be careful not to pinch them firmly with pliers. The pipes may get deformed.</li> <li>■ Provide a protective sheet or a steel plate so that the brazing flame cannot influence peripheries.</li> <li>■ Be careful so as not to burn the compressor terminals, the name plate, the heat exchanger fin.</li> </ul>		<p><b>Caution</b> From the viewpoint of global environment protection, do not discharge the refrigerant gas in the atmosphere. Make sure to collect all the refrigerant gas.</p>
		<p><b>Cautions for restoration</b></p> <ol style="list-style-type: none"> <li>1. Restore the piping by non-oxidation brazing.</li> <li>2. Avoid excessive heating. (Keep below 120°C)</li> </ol>
		<p><b>In case of difficulty with gas brazing machine</b></p> <ol style="list-style-type: none"> <li>1. Disconnect the brazed part where is easy to disconnect and restore.</li> <li>2. Cut pipes on the main unit with a tube cutter in order to make it easy to disconnect.</li> </ol>

# 6. Removal of Compressor ASSY (Pattern 1)

**Procedure**



**Warning** Be sure to wait for 10 minutes or more after turning off all power supplies before disassembling work.

Step	Procedure	Procedure	Points
1	Remove the terminal cover.	<p>Terminal cover</p> <p>(R5455)</p> <p>Terminal cover fixture</p> <p>(R5456)</p>	
2	Disconnect the compressor lead wires.	<p>Red (R)</p> <p>Blue (C)</p> <p>Yellow (S)</p> <p>(R5457)</p>	<p>■ Be careful so as not to burn the compressor terminals or the name plate.</p> <p>(R12819)</p>
3	Remove the gasket.	<p>Gasket</p> <p>(R5458)</p>	<p>S : yellow C : blue R : red</p>

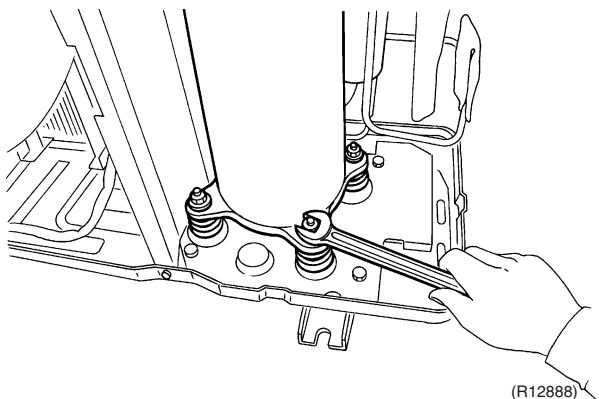
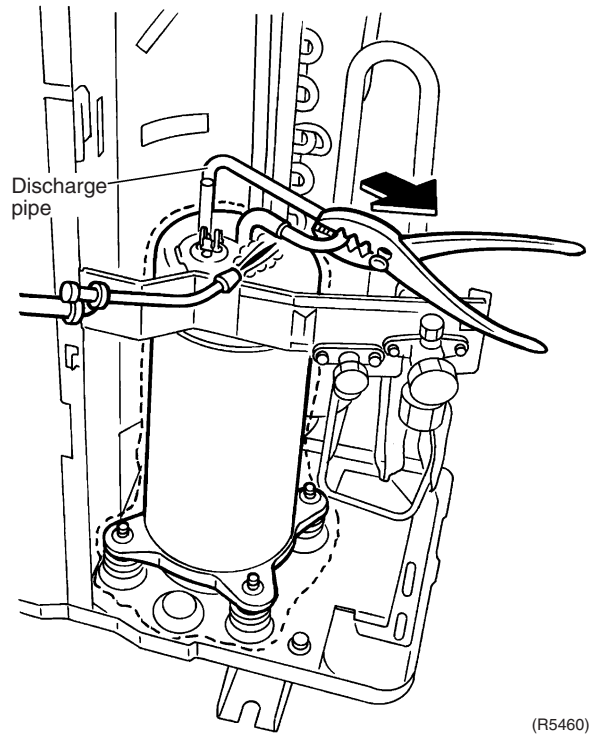
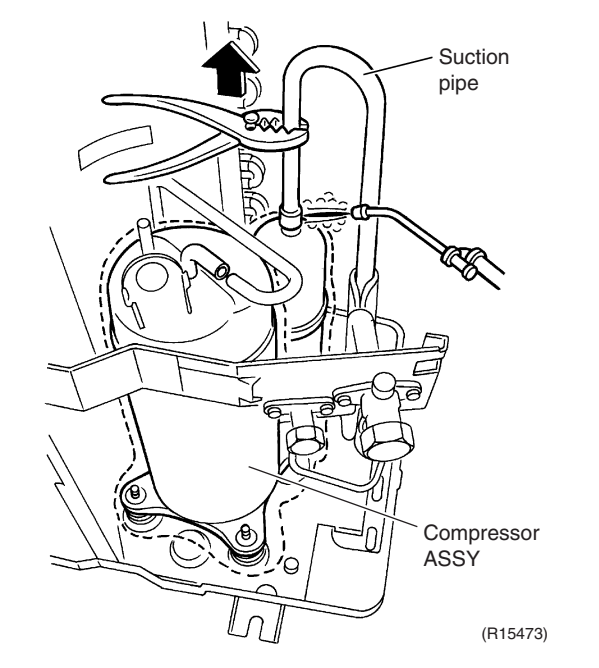
Step	Procedure	Points
4	Remove the 4 nuts of the compressor.	<p><b>Warning</b> Be careful not to get yourself burnt with the pipes and other parts that are heated by the gas brazing machine.</p>
<ul style="list-style-type: none"> <li>■ Before working, make sure that the refrigerant gas is empty in the circuit.</li> <li>■ Be sure to apply nitrogen replacement when heating up the brazed part.</li> </ul>	 <p style="text-align: right;">(R12888)</p>	<p><b>Warning</b> If the refrigerant gas leaks during work, ventilate the room. (If the refrigerant gas is exposed to flames, toxic gas may be generated.)</p>
5	Heat up the brazed part of the discharge side and disconnect.	<p><b>Warning</b> Since it may happen that the refrigerant oil in the compressor catches fire, prepare wet cloth so as to extinguish fire immediately.</p>
6	Heat up the brazed part of the suction side and disconnect.	<p><b>Caution</b> From the viewpoint of global environment protection, do not discharge the refrigerant gas in the atmosphere. Make sure to collect all the refrigerant gas.</p>
7	Lift the compressor ASSY up and remove it.	<p><b>Cautions for restoration</b></p> <ol style="list-style-type: none"> <li>1. Restore the piping by non-oxidation brazing.</li> <li>2. Avoid excessive heating. (Keep below 120°C)</li> </ol>
<p><b>Note:</b></p> <ul style="list-style-type: none"> <li>■ Do not use a metal saw for cutting pipes by all means because the sawdust comes into the circuit.</li> <li>■ When withdrawing the pipes, be careful not to pinch them firmly with pliers. The pipes may get deformed.</li> <li>■ Provide a protective sheet or a steel plate so that the brazing flame cannot influence peripheries.</li> <li>■ Be careful so as not to burn the compressor terminals, the name plate, the heat exchanger fin.</li> </ul>	 <p style="text-align: right;">(R5460)</p>  <p style="text-align: right;">(R15473)</p>	<p><b>In case of difficulty with gas brazing machine</b></p> <ol style="list-style-type: none"> <li>1. Disconnect the brazed part where is easy to disconnect and restore.</li> <li>2. Cut pipes on the main unit with a tube cutter in order to make it easy to disconnect.</li> </ol>



# 7. Removal of Compressor ASSY (Pattern 2)

**Procedure**

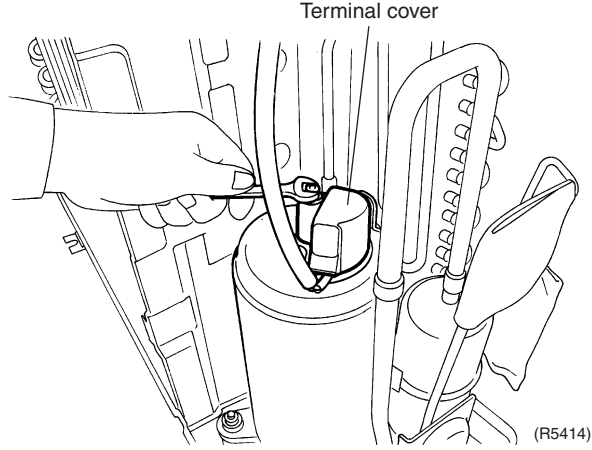
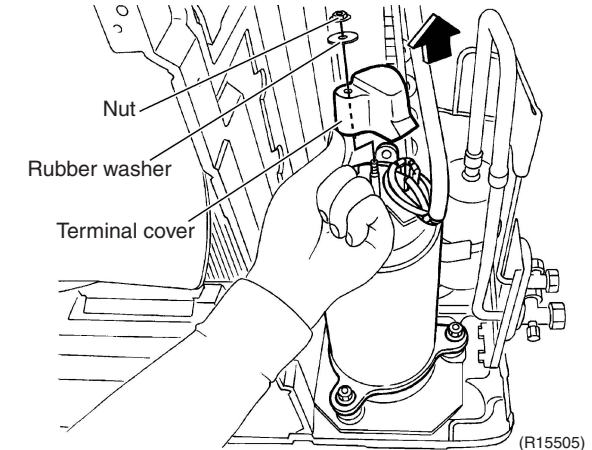
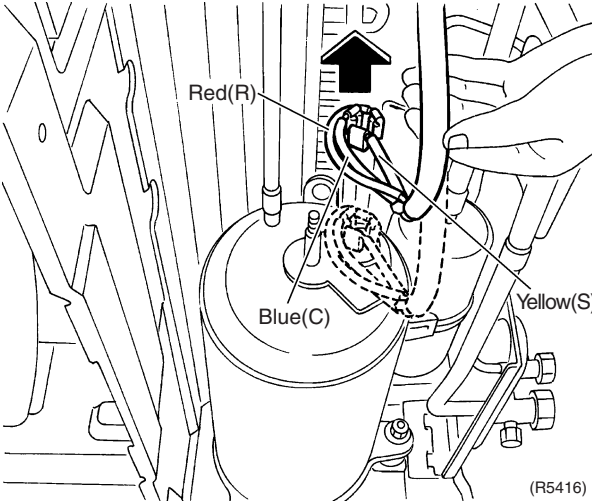
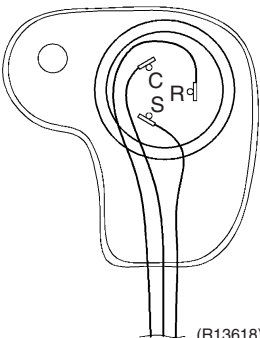

**Warning** Be sure to wait for 10 minutes or more after turning off all power supplies before disassembling work.

Step	Procedure	Points
1	Remove the nut and remove the terminal cover.	 <p>(R5414)</p>  <p>(R15505)</p>
2	Disconnect the compressor lead wires.	 <p>(R5416)</p>  <p>(R13618)</p> <p>S : yellow C : blue R : red</p>

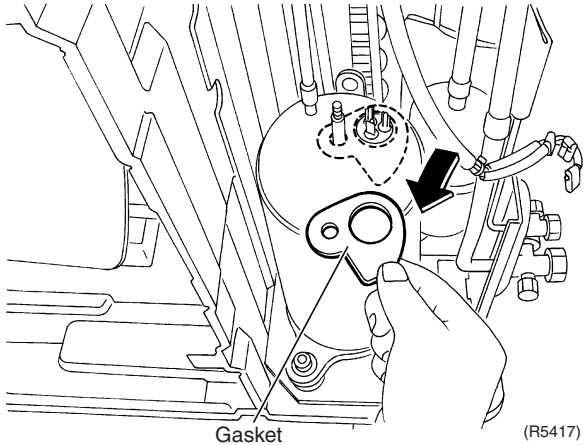
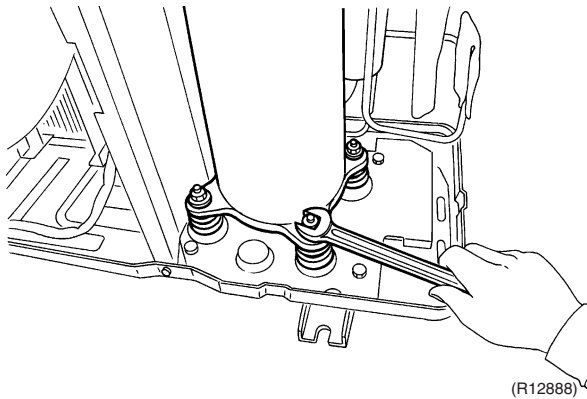
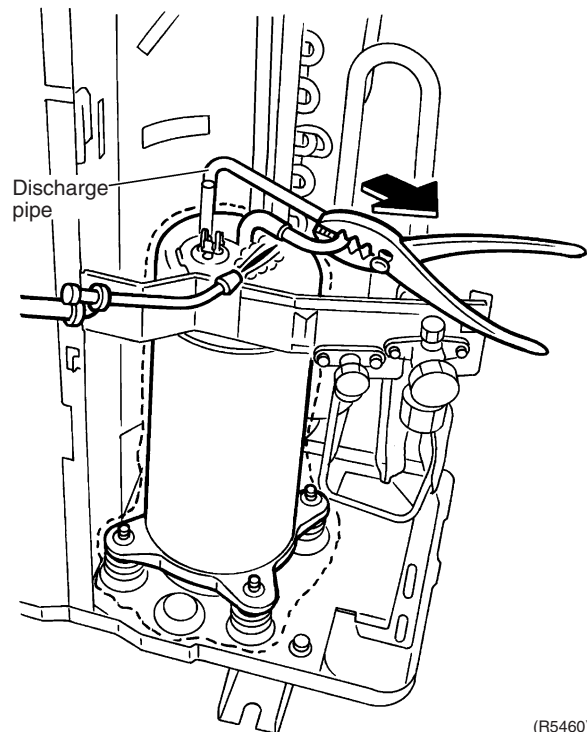
Step	Procedure	Points
3	Remove the gasket.	<p><b>Warning</b> Be careful not to get yourself burnt with the pipes and other parts that are heated by the gas brazing machine.</p>
4	Remove the 4 nuts of the compressor.	<p><b>Warning</b> If the refrigerant gas leaks during work, ventilate the room. (If the refrigerant gas is exposed to flames, toxic gas may be generated.)</p>
<ul style="list-style-type: none"> <li>■ Before working, make sure that the refrigerant gas is empty in the circuit.</li> <li>■ Be sure to apply nitrogen replacement when heating up the brazed part.</li> </ul>	 <p style="text-align: center;">Gasket (R5417)</p>  <p style="text-align: center;">(R12888)</p>	<p><b>Warning</b> Since it may happen that the refrigerant oil in the compressor catches fire, prepare wet cloth so as to extinguish fire immediately.</p>
	 <p style="text-align: center;">Discharge pipe (R5460)</p>	<p><b>Caution</b> From the viewpoint of global environment protection, do not discharge the refrigerant gas in the atmosphere. Make sure to collect all the refrigerant gas.</p>
5	Heat up the brazed part of the discharge side and disconnect.	<p><b>Cautions for restoration</b></p> <ol style="list-style-type: none"> <li>1. Restore the piping by non-oxidation brazing.</li> <li>2. Avoid excessive heating. (Keep below 120°C)</li> </ol>
6	Heat up the brazed part of the suction side and disconnect.	<p><b>In case of difficulty with gas brazing machine</b></p> <ol style="list-style-type: none"> <li>1. Disconnect the brazed part where is easy to disconnect and restore.</li> <li>2. Cut pipes on the main unit with a tube cutter in order to make it easy to disconnect.</li> </ol>

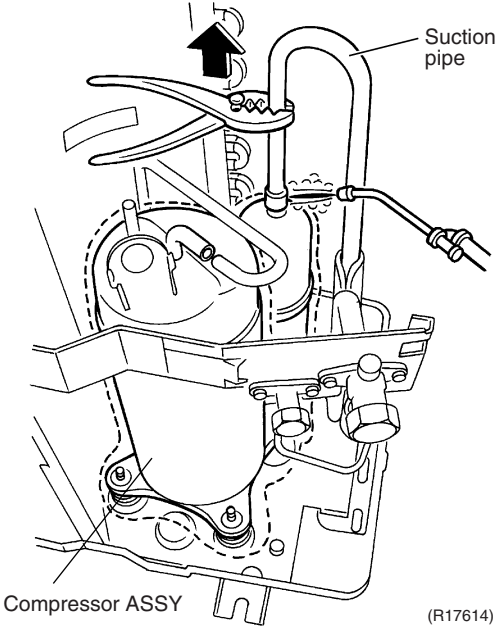
Step	Procedure	Points
	 <p>The diagram illustrates the removal of the compressor assembly. A suction pipe is shown being cut with a metal saw. The compressor assembly is labeled 'Compressor ASSY' and the diagram is identified as '(R17614)'. An arrow points to the suction pipe being cut.</p>	<p><b>Note:</b></p> <ul style="list-style-type: none"><li>■ Do not use a metal saw for cutting pipes by all means because the sawdust comes into the circuit.</li><li>■ When withdrawing the pipes, be careful not to pinch them firmly with pliers. The pipes may get deformed.</li><li>■ Provide a protective sheet or a steel plate so that the brazing flame cannot influence peripheries.</li><li>■ Be careful so as not to burn the compressor terminals, the name plate, the heat exchanger fins.</li></ul>

# Revision History

Month / Year	Version	Revised contents
08/2012	Si011197	First edition

Warning



- Daikin products are manufactured for export to numerous countries throughout the world. Prior to purchase, please confirm with your local authorised importer, distributor and/or retailer whether this product conforms to the applicable standards, and is suitable for use, in the region where the product will be used. This statement does not purport to exclude, restrict or modify the application of any local legislation.
- Ask a qualified installer or contractor to install this product. Do not try to install the product yourself. Improper installation can result in water or refrigerant leakage, electrical shock, fire or explosion.
- Use only those parts and accessories supplied or specified by Daikin. Ask a qualified installer or contractor to install those parts and accessories. Use of unauthorised parts and accessories or improper installation of parts and accessories can result in water or refrigerant leakage, electrical shock, fire or explosion.
- Read the User's Manual carefully before using this product. The User's Manual provides important safety instructions and warnings. Be sure to follow these instructions and warnings.

If you have any enquiries, please contact your local importer, distributor and/or retailer.

### Cautions on product corrosion

1. Air conditioners should not be installed in areas where corrosive gases, such as acid gas or alkaline gas, are produced.
2. If the outdoor unit is to be installed close to the sea shore, direct exposure to the sea breeze should be avoided. If you need to install the outdoor unit close to the sea shore, contact your local distributor.

### Dealer

### **DAIKIN INDUSTRIES, LTD.**

Head Office:  
Umeda Center Bldg., 2-4-12, Nakazaki-Nishi,  
Kita-ku, Osaka, 530-8323 Japan

Tokyo Office:  
JR Shinagawa East Bldg., 2-18-1, Konan,  
Minato-ku, Tokyo, 108-0075 Japan

[http://www.daikin.com/global\\_ac/](http://www.daikin.com/global_ac/)

©All rights reserved