



REMOVAL PROCEDURE



S E R V I C E M A N U A L

5.0 kW Class 18000 Btu/h Class

-  Outdoor Unit
-  Non-Inverter
-  Pair Type



Service Manual Removal Procedure

Outdoor Unit

Applicable Models

●Cooling Only

R18LV2S

RE18NV2S

AR18KV2S

R50HV1

R50HV14

R50JV1V

R50MV16

Table of Contents

1. Removal of Outer Panels	2
2. Removal of Outdoor Fan / Fan Motor (Pattern 1)	4
3. Removal of Outdoor Fan / Fan Motor (Pattern 2)	6
4. Removal of Electrical Components (Pattern 1)	8
5. Removal of Electrical Components (Pattern 2)	16
6. Removal of Sound Blankets	24
7. Removal of Capillary Tube (Pattern 1)	25
8. Removal of Capillary Tube (Pattern 2)	26
9. Removal of Compressor ASSY	27



Note:

- ◆ The illustrations may be slightly different depending on the model.

1. Removal of Outer Panels

Procedure



Warning Be sure to wait for 10 minutes or more after turning off all power supplies before disassembling work.

Step	Procedure	Procedure	Points
1	Remove the 4 screws and remove the top panel.	<p style="text-align: center;">Top panel</p> <p style="text-align: right;">(R15386)</p> <p style="text-align: right;">(R15384)</p>	<ul style="list-style-type: none"> ■ Take care not to cut your finger by the fins of the outdoor heat exchanger.
2	Remove the 7 screws of the front panel.	<p style="text-align: left;">Front panel</p> <p style="text-align: right;">(R15387)</p>	

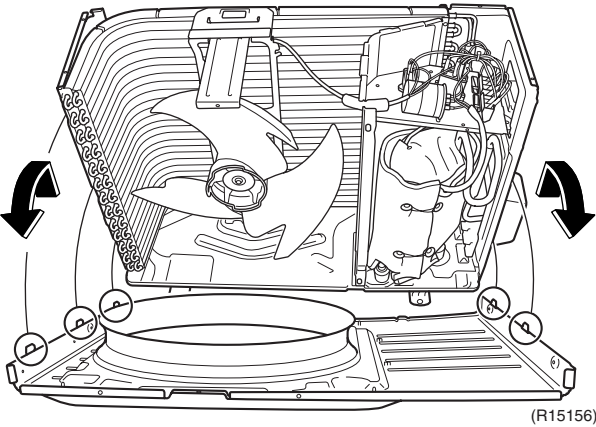
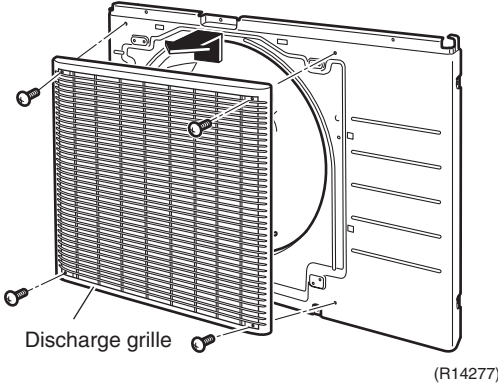
Step	Procedure	Points
3	Lift the front panel and unfasten the 3 hooks of the left side and 2 hooks of the right side.	
	 <p>(R15156)</p>	
4	Remove the 4 screws and remove the discharge grille.	
	 <p>Discharge grille</p> <p>(R14277)</p>	

2. Removal of Outdoor Fan / Fan Motor (Pattern 1)

Procedure

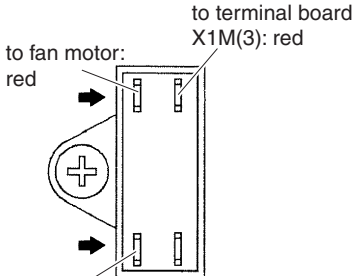
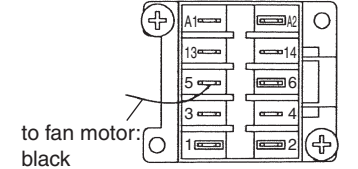
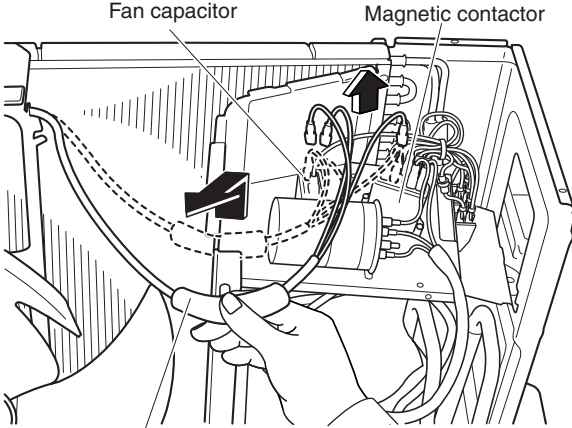
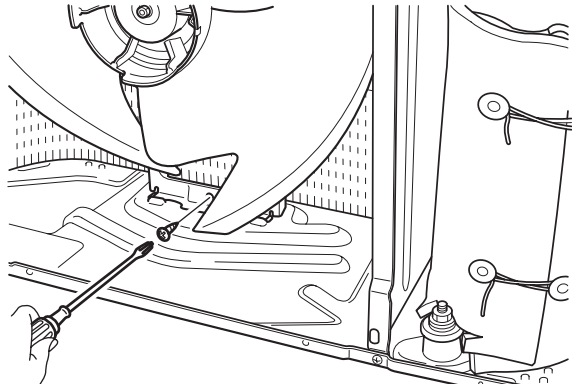
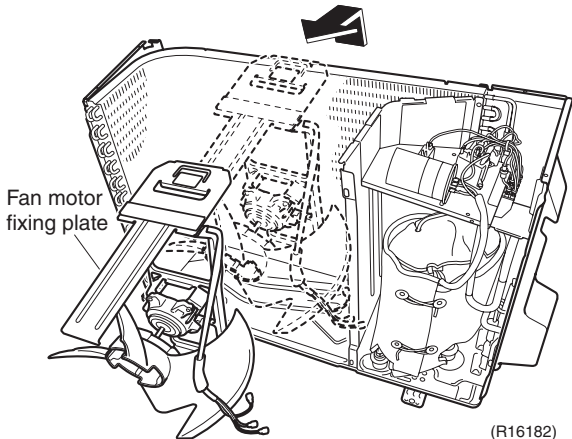
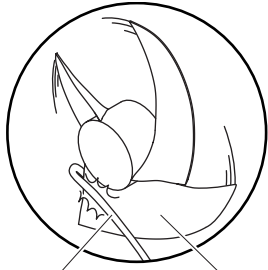

Warning Be sure to wait for 10 minutes or more after turning off all power supplies before disassembling work.

Step	Procedure	Points
1	Pull out the 2 terminals from the fan capacitor (C2R).	<p>■ Fan capacitor (C2R)</p>  <p>to fan motor: red</p> <p>to terminal board X1M(3): red</p> <p>to fan motor: white</p> <p>(R17459)</p>
2	Pull out the terminal [5] from the magnetic contactor (K1M).	<p>■ Magnetic contactor (K1M)</p>  <p>to fan motor: black</p> <p>(R17460)</p>
3	Release the fan motor lead wire from the hook.	<p>■ Be careful so as not to damage the top part of the outdoor heat exchanger fins.</p> <p>■ Put the fan motor lead wire through the back of the fan motor when reassembling so as not to be entangled with the outdoor fan.</p>  <p>Fan capacitor</p> <p>Magnetic contactor</p> <p>Fan motor lead wire</p> <p>(R16343)</p>  <p>(R15158)</p>
4	Remove the screw of the fan motor fixing plate.	 <p>Fan motor fixing plate</p> <p>(R16182)</p>  <p>Lead wire</p> <p>Outdoor fan</p> <p>(R3249)</p>
5	Remove the fan motor fixing plate.	

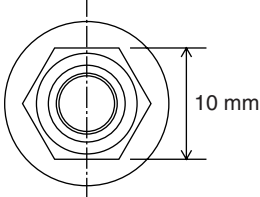
Step	Procedure	Points
6	Remove the nut and remove the outdoor fan.	<ul style="list-style-type: none"> When reassembling, fit the lower hooks into the bottom frame.
7	Unfasten the 2 hooks. Release the fan motor lead wire.	<ul style="list-style-type: none"> Nut size: M6  <p>(R17447)</p> <ul style="list-style-type: none"> Align the ▼ mark of the outdoor fan with the D-cut section of the motor shaft when reassembling.
8	Remove the 4 screws and remove the fan motor.	<ul style="list-style-type: none"> Screw size: M4 x 16

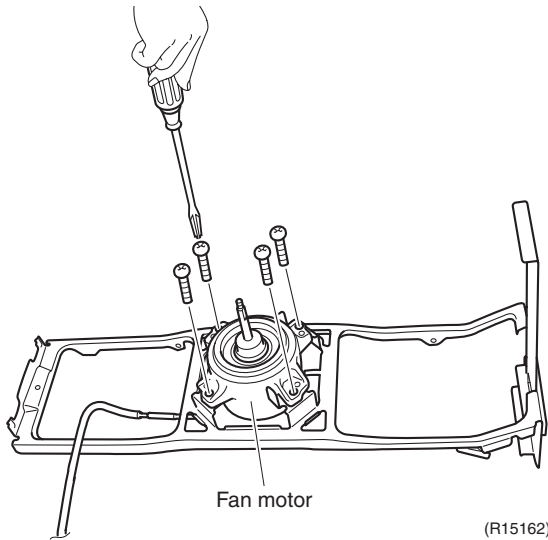
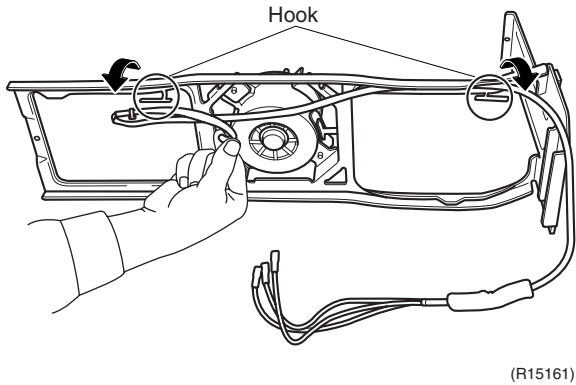
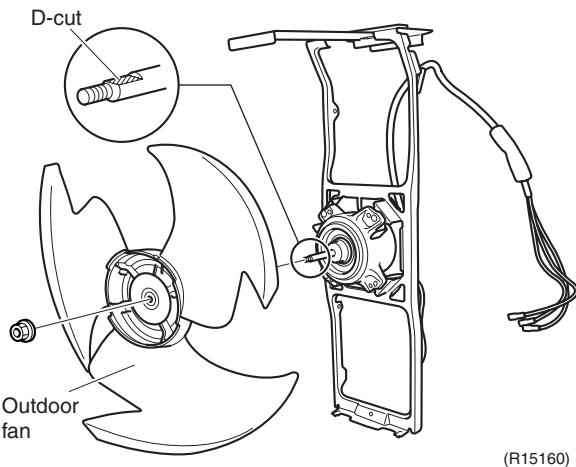
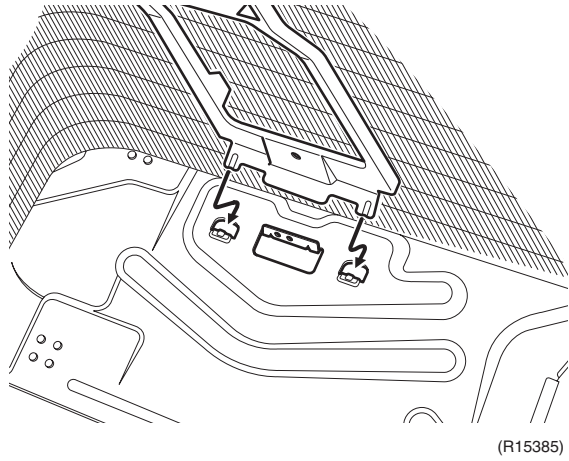

3. Removal of Outdoor Fan / Fan Motor (Pattern 2)

Procedure



Warning Be sure to wait for 10 minutes or more after turning off all power supplies before disassembling work.

Step	Procedure	Procedure	Points
<p>1 Pull out the 2 terminals from the fan capacitor (C2R).</p> <p>2 Pull out the terminal [5] from the magnetic contactor (K1M).</p> <p>3 Release the fan motor lead wire from the hook.</p>		<p>(R16343)</p>	<p>■ Fan capacitor (C2R)</p> <p>to fan motor: red</p> <p>to fan motor: white</p> <p>(R17634)</p>
<p>4 Remove the screw of the fan motor fixing plate.</p>		<p>(R15158)</p>	<p>■ Magnetic contactor (K1M)</p> <p>to fan motor: black</p> <p>(R17635)</p>
<p>5 Remove the fan motor fixing plate.</p>		<p>Fan motor fixing plate</p> <p>(R16182)</p>	<p>■ Be careful so as not to damage the top part of the outdoor heat exchanger fins.</p> <p>■ Put the lead wire through the back of the motor when reassembling so as not to be entangled with the outdoor fan.</p> <p>Lead wire Outdoor fan</p> <p>(R3249)</p>

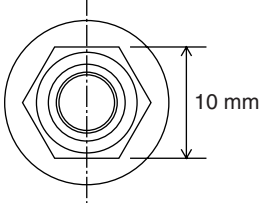
Step	Procedure	Points
6	Remove the nut and remove the outdoor fan.	<ul style="list-style-type: none"> When reassembling, fit the lower hooks into the bottom frame.
7	Unfasten the 2 hooks. Release the fan motor lead wire.	<ul style="list-style-type: none"> Nut size: M6  <ul style="list-style-type: none"> Align the ▼ mark of the outdoor fan with the D-cut section of the motor shaft when reassembling.
8	Remove the 4 screws and remove the fan motor.	<ul style="list-style-type: none"> Screw size: M4 × 16

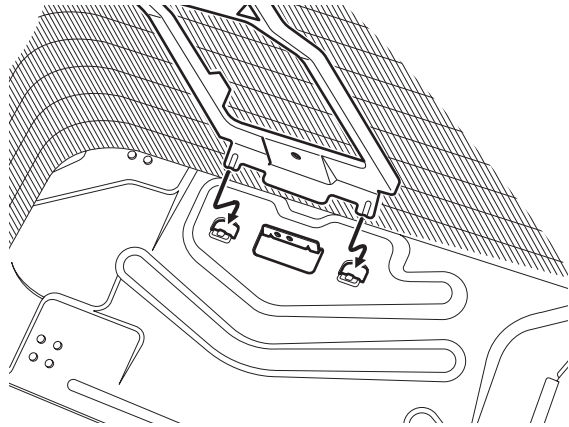

(R15385)

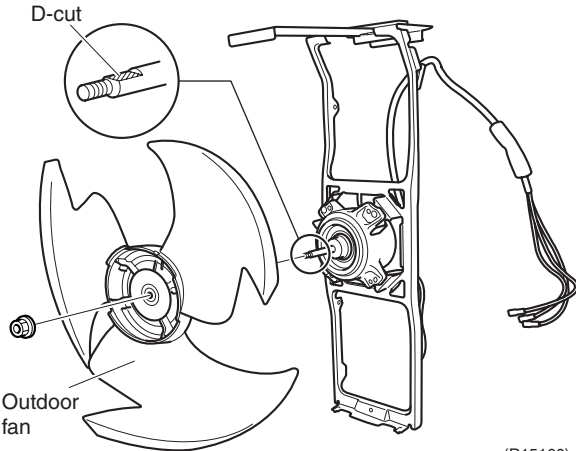

(R15160)

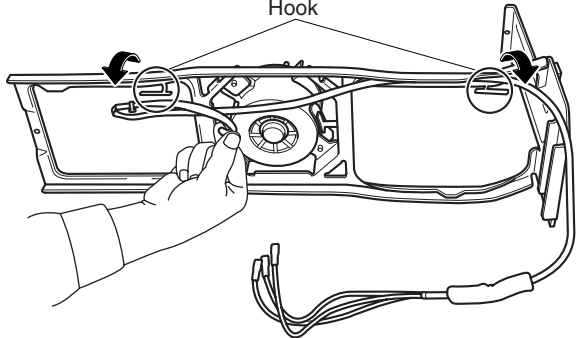

(R15161)

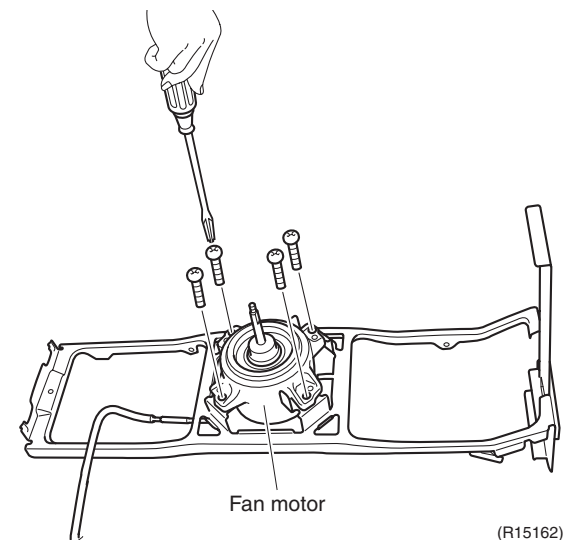

(R15162)

4. Removal of Electrical Components (Pattern 1)

Procedure



Warning Be sure to wait for 10 minutes or more after turning off all power supplies before disassembling work.

Step	Procedure	Points
1. Remove the right side panel.	<p style="text-align: center;">Stop valve cover</p> <p style="text-align: right;">(R16344)</p> <p style="text-align: right;">(R16345)</p>	<p>■ The stop valve cover has 3 hooks.</p>
2 Remove the 3 screws and remove the wire clamp.	<p style="text-align: center;">Wire clamp</p> <p style="text-align: right;">(R15165)</p>	

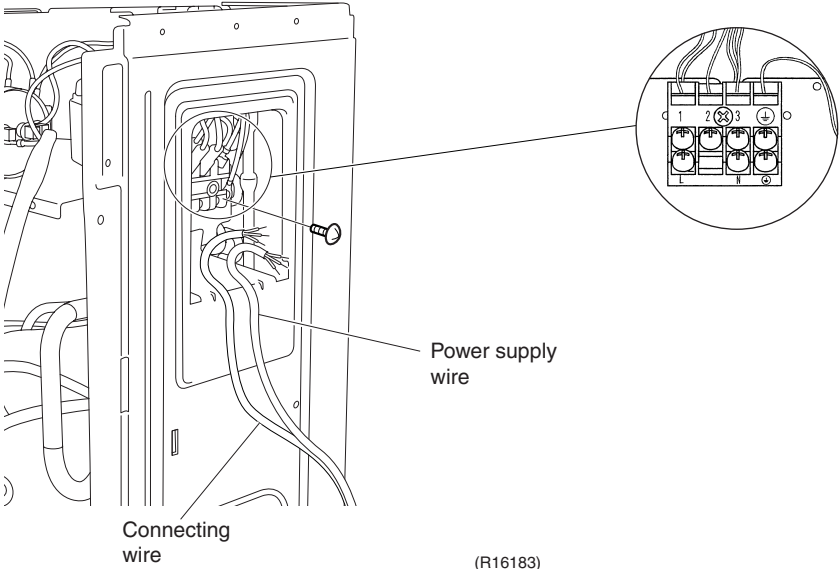
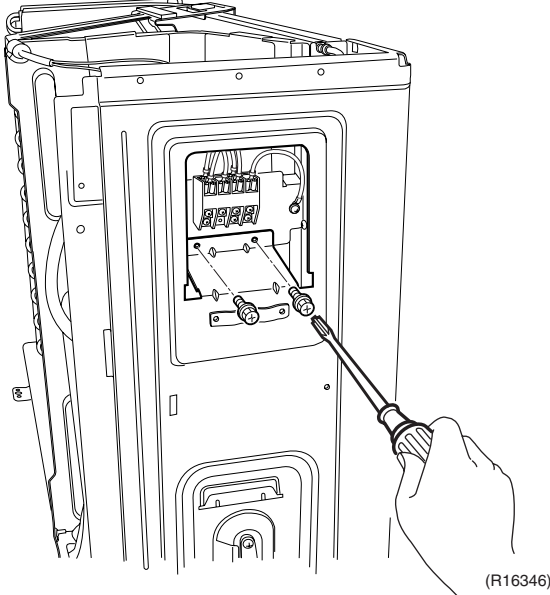
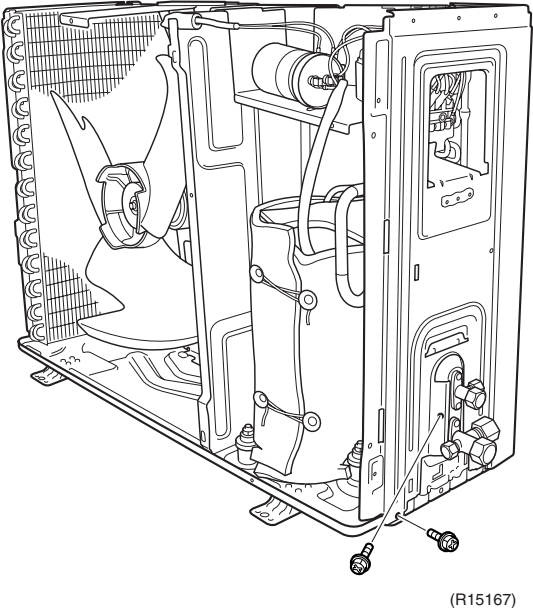
Step	Procedure	Points
3	Remove the 7 screws on the terminal board and disconnect the connecting wire and the power supply wire.	 <p>Connecting wire</p> <p>Power supply wire</p> <p>(R16183)</p>
4	Remove the 2 screws on the right side (upper).	 <p>(R16346)</p>
5	Remove the 2 screws on the right side (lower).	 <p>(R15167)</p>

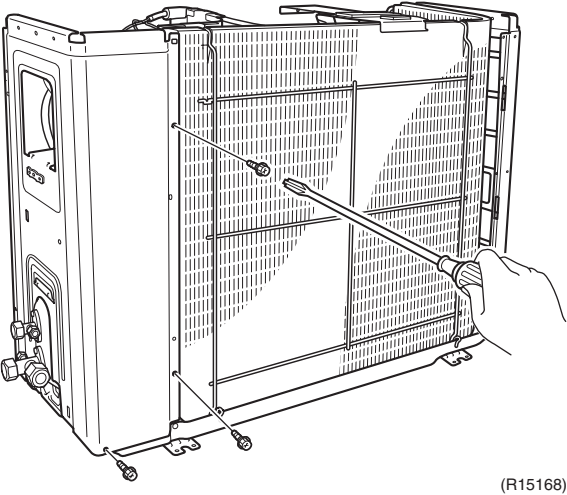
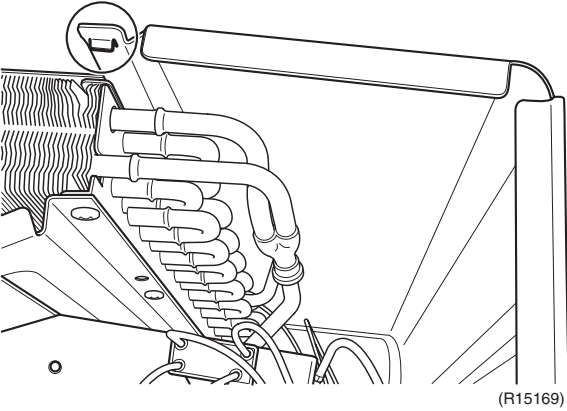
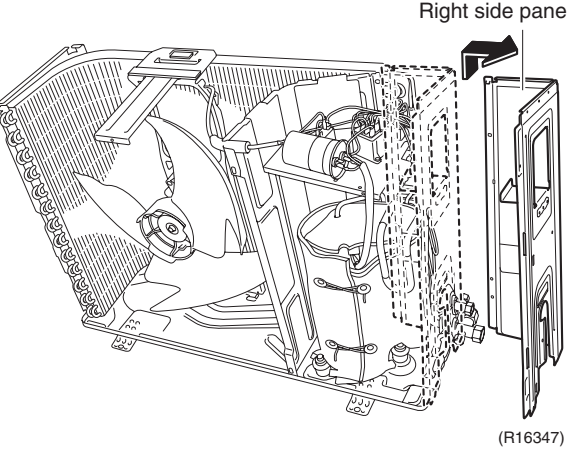
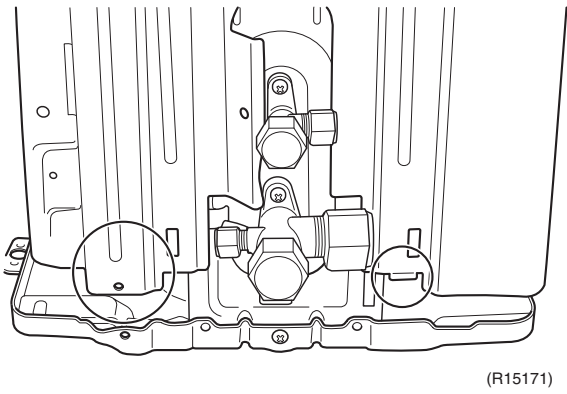
Step	Procedure	Points
6	Remove the 3 screws on the rear side.	
	 <p style="text-align: right;">(R15168)</p>	
7	Unfasten the hook.	
	 <p style="text-align: right;">(R15169)</p>	
8	Remove the right side panel.	
	 <p style="text-align: right;">(R16347)</p>	
	 <p style="text-align: right;">(R15171)</p>	<p>■ The right side panel has 2 hooks at the bottom.</p>

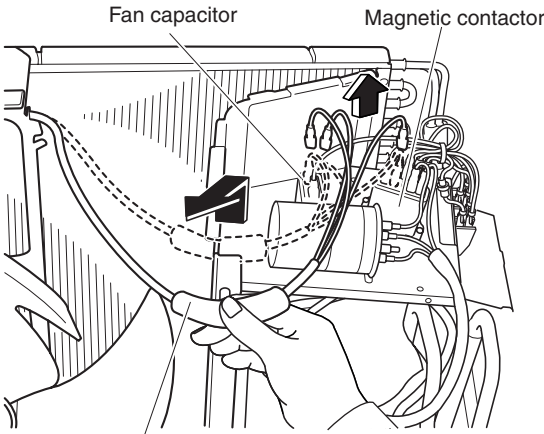
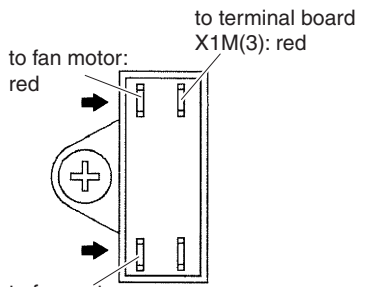
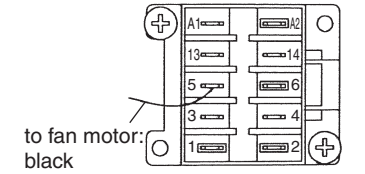
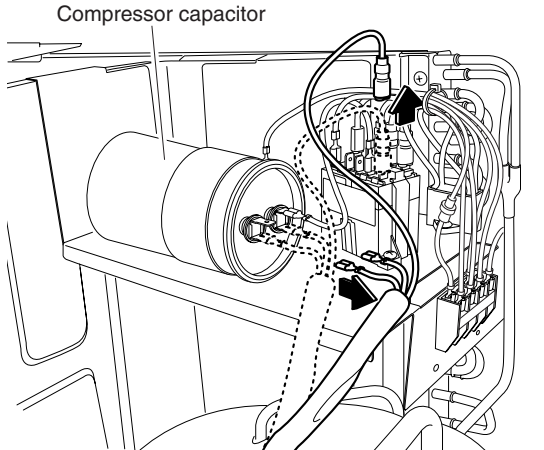
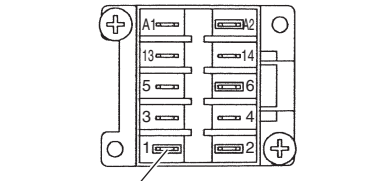
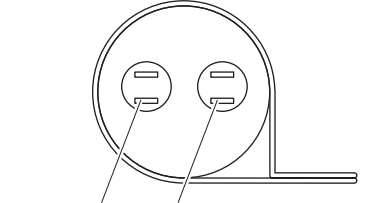
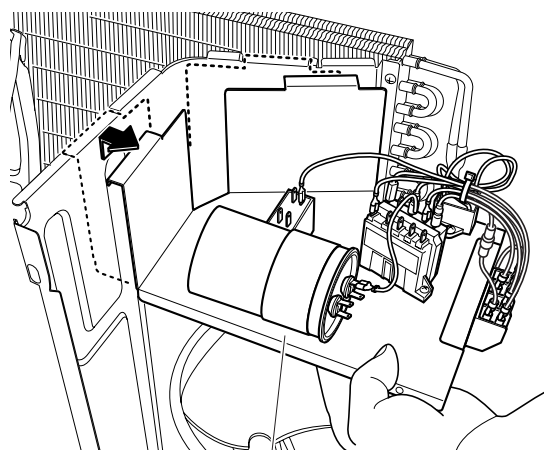
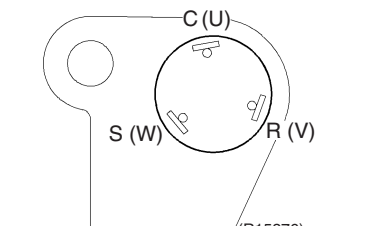
Step	Procedure	Points
<p>2. Remove the electrical component ASSY.</p>		<p>■ Fan capacitor (C2R)</p>  <p>(R17459)</p>
<p>1 Pull out the 2 terminals from the fan capacitor (C2R).</p>	<p>Fan motor lead wire</p>	<p>■ Magnetic contactor (K1M)</p>  <p>(R17460)</p>
<p>2 Pull out the terminal [5] from the magnetic contactor (K1M).</p>		<p>■ The design of magnetic contactor varies depending on the model.</p> <p>■ Magnetic contactor (K1M)</p>  <p>(R17461)</p>
<p>3 Release the fan motor lead wire from the hook.</p>	<p>(R16343)</p>	<p>■ Compressor capacitor (C1R)</p>  <p>(R17462)</p>
<p>4 Pull out the terminal [1] from the magnetic contactor (K1M).</p>		<p>■ Compressor lead wire</p>  <p>(R15376)</p> <p>S (W): yellow C (U): blue R (V): red</p>
<p>5 Pull out the 2 terminals from the compressor capacitor (C1R).</p>	<p>(R16348)</p>	
<p>6 Lift and remove the electrical component ASSY.</p>	<p>(R16350)</p>	

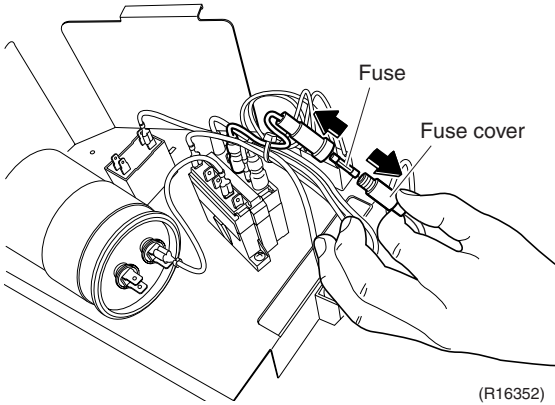
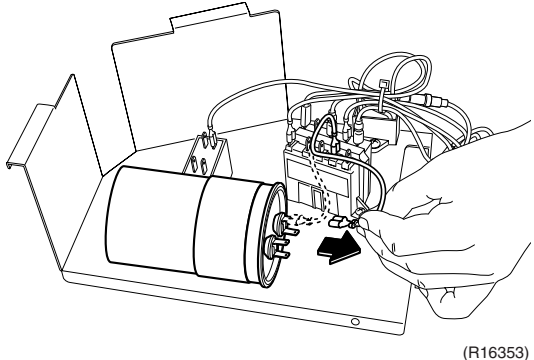
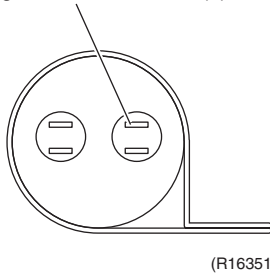
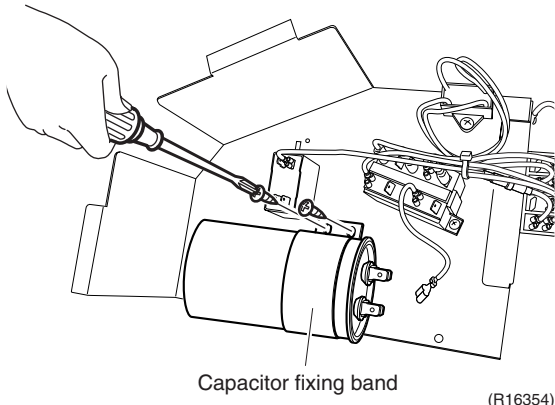
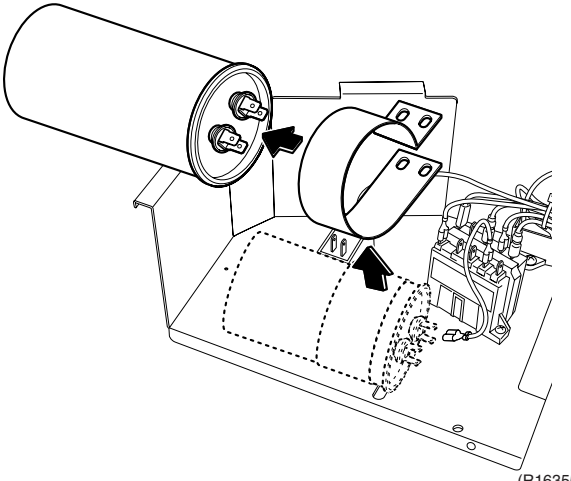
Step	Procedure	Points
3. Remove the electrical components.		
1	Open the fuse cover and remove the fuse.	
	 <p>(R16352)</p>	
2	Pull out the remaining terminal from the compressor capacitor (C1R).	<p>■ Compressor capacitor (C1R) to magnetic contactor K1M(3): red</p>
	 <p>(R16353)</p>	 <p>(R16351)</p>
3	Remove the 2 screws of the capacitor fixing band.	
	 <p>Capacitor fixing band</p> <p>(R16354)</p>	
4	Remove the compressor capacitor.	
	 <p>(R16355)</p>	

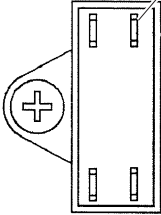
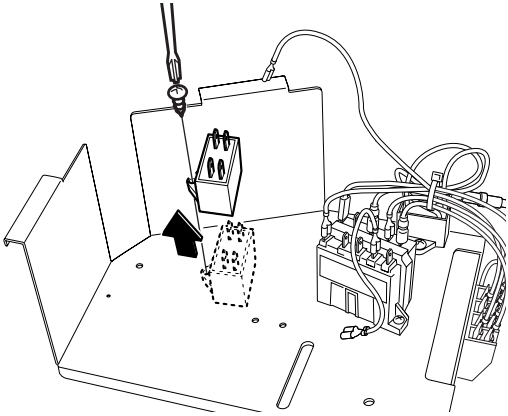
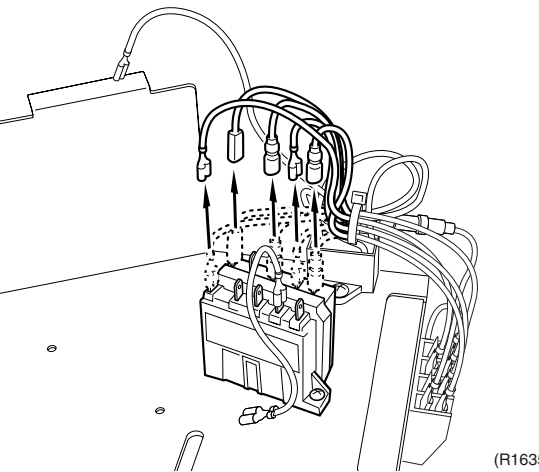
Step	Procedure	Points
5	Pull out the terminal from the fan capacitor (C2R).	<p>■ Fan capacitor (C2R) to terminal board X1M(3): red</p>  <p>(R16184)</p>
6	Remove the screw and remove the fan capacitor.	 <p>(R16356)</p>
7	Pull out the terminals [2] [4] [6] [A1] [A2] from the magnetic contactor (K1M).	 <p>(R16358)</p>

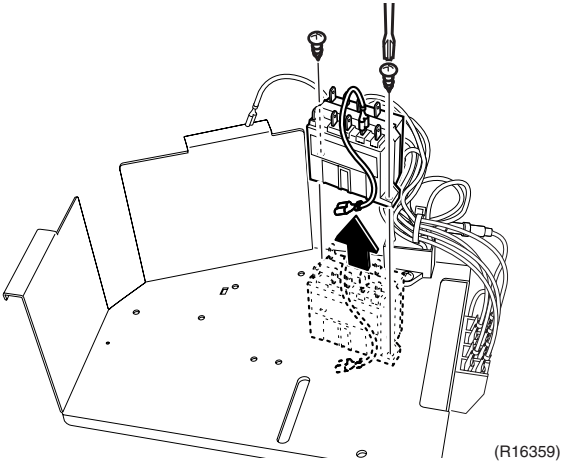
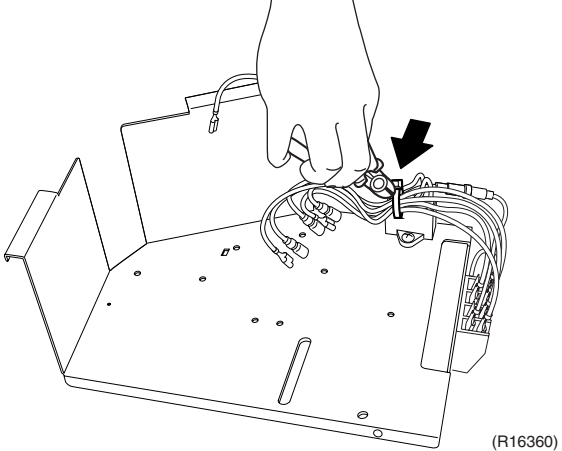
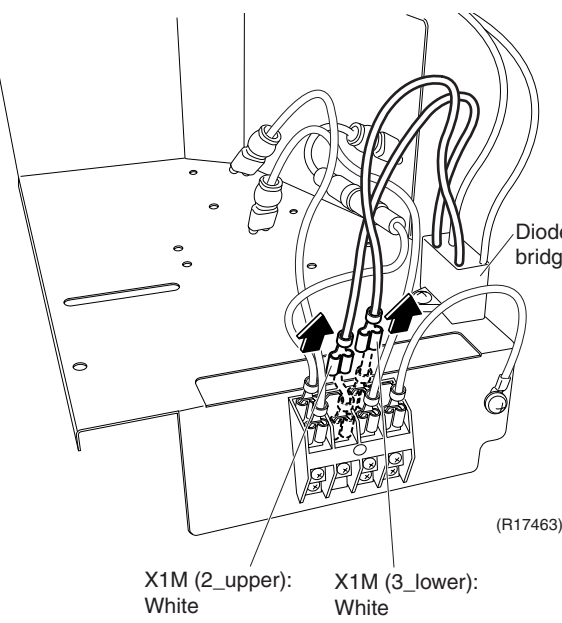
Step	Procedure	Points
8	Remove the 2 screws and remove the magnetic contactor.	
		
9	Cut the clamp.	
		
10	Pull out the 2 terminals for the diode bridge (V1R) from the terminal board.	
	 <p data-bbox="644 1805 794 1856">X1M (2_upper): White</p> <p data-bbox="836 1805 986 1856">X1M (3_lower): White</p> <p data-bbox="1018 1464 1082 1503">Diode bridge</p> <p data-bbox="995 1756 1066 1771">(R17463)</p>	

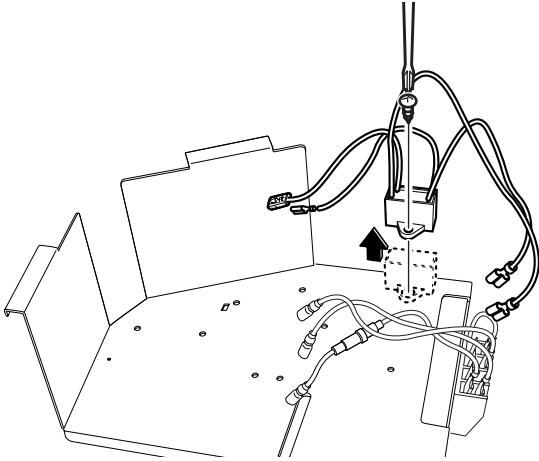
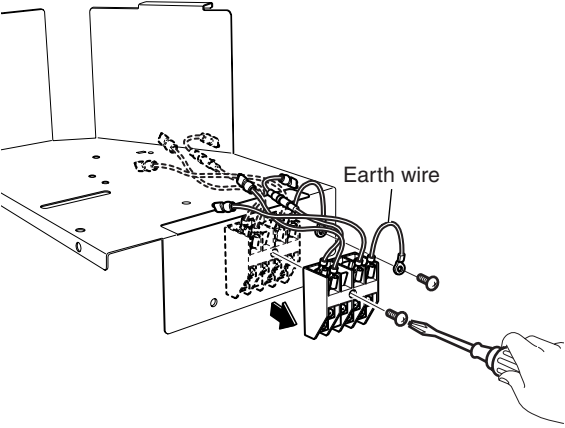
Step	Procedure	Points
11	Remove the screw and remove the diode bridge.	 <p>(R17185)</p>
12	Remove the screw of the earth wire and the screw of the terminal board.	 <p>Earth wire</p> <p>(R17152)</p>
13	Remove the terminal board.	

5. Removal of Electrical Components (Pattern 2)

Procedure



Warning Be sure to wait for 10 minutes or more after turning off all power supplies before disassembling work.

Step	Procedure	Points
1. Remove the right side panel.	<p style="text-align: center;">Stop valve cover</p> <p style="text-align: right;">(R16344)</p> <p style="text-align: right;">(R16345)</p>	<p>■ The stop valve cover has 3 hooks.</p>
2 Remove the 3 screws and remove the wire clamp.	<p style="text-align: center;">Wire clamp</p> <p style="text-align: right;">(R15165)</p>	

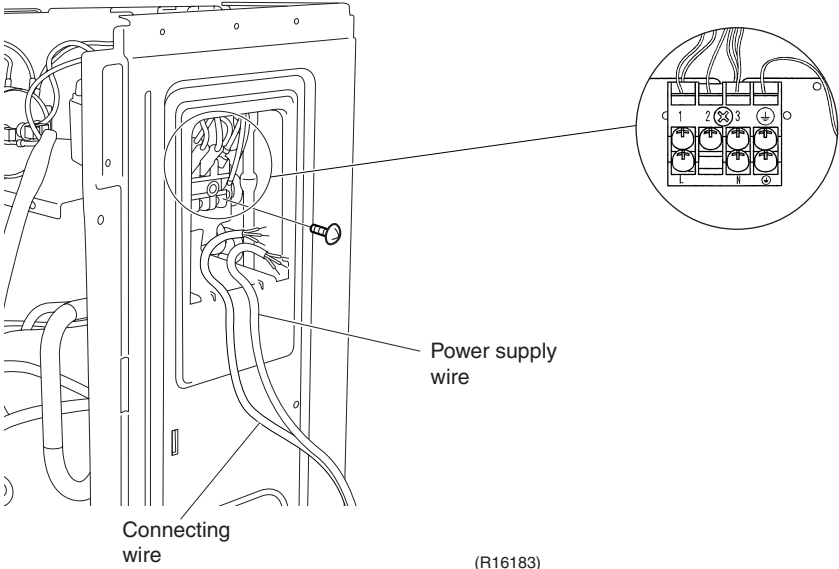
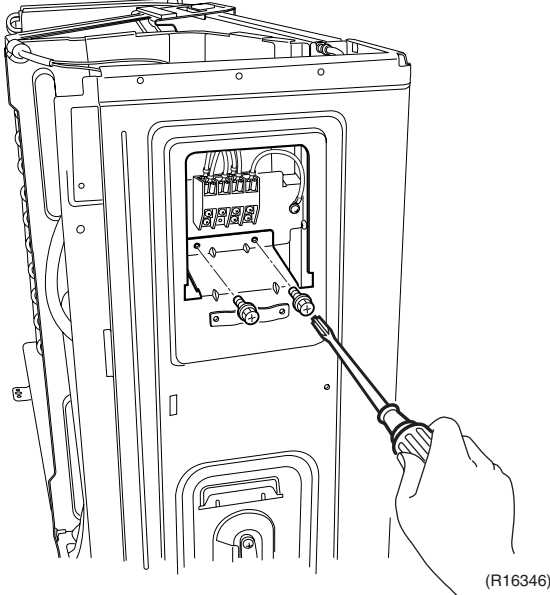
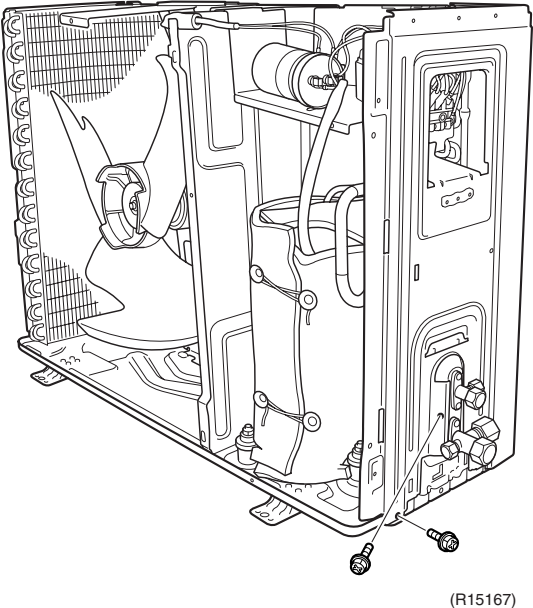
Step	Procedure	Points
3	Remove the 7 screws on the terminal board and disconnect the connecting wire and the power supply wire.	 <p>Connecting wire</p> <p>Power supply wire</p> <p>(R16183)</p>
4	Remove the 2 screws on the right side (upper).	 <p>(R16346)</p>
5	Remove the 2 screws on the right side (lower).	 <p>(R15167)</p>

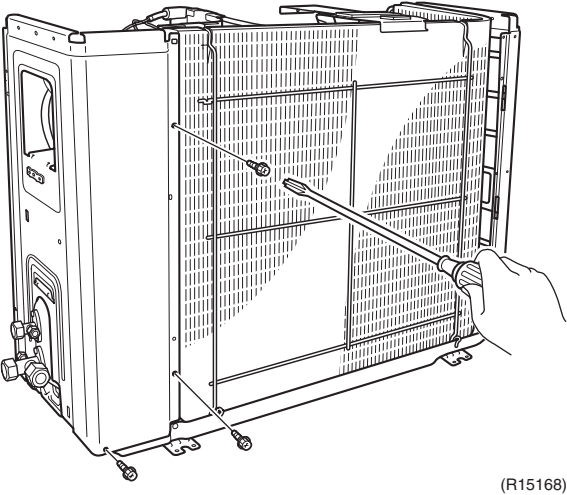
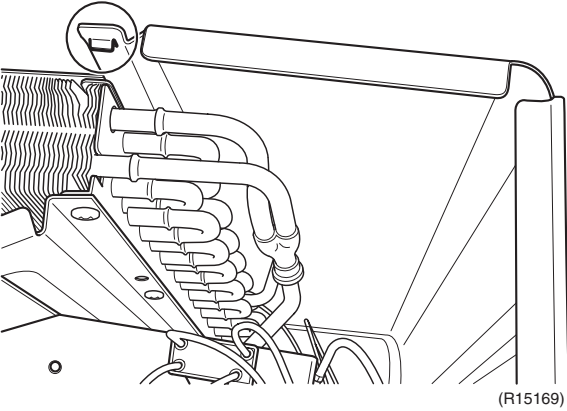
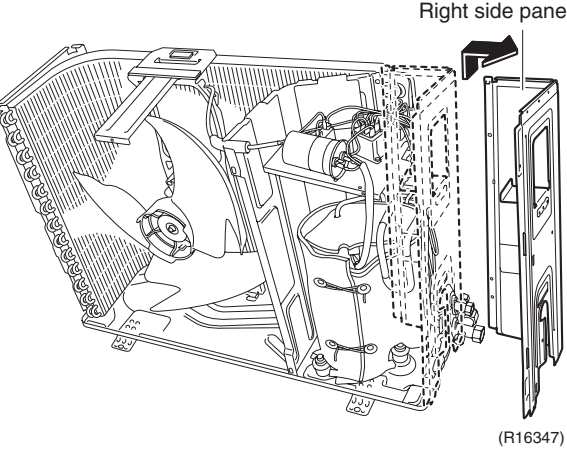
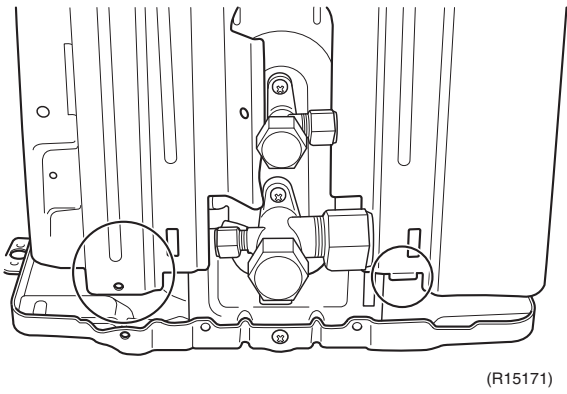
Step	Procedure	Points
6	Remove the 3 screws on the rear side.	
	 <p style="text-align: right;">(R15168)</p>	
7	Unfasten the hook.	
	 <p style="text-align: right;">(R15169)</p>	
8	Remove the right side panel.	
	 <p style="text-align: right;">(R16347)</p>	
	 <p style="text-align: right;">(R15171)</p>	<p>■ The right side panel has 2 hooks at the bottom.</p>

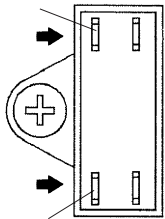
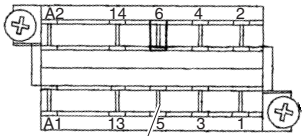
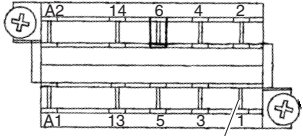
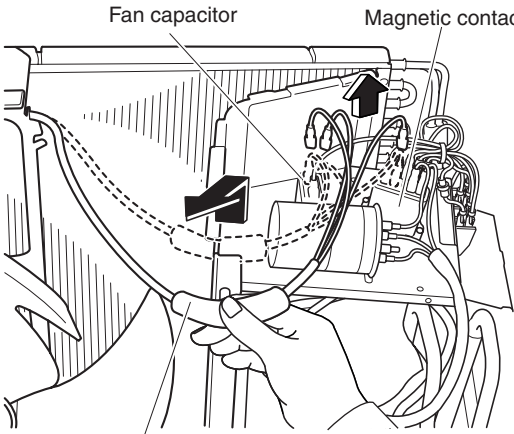
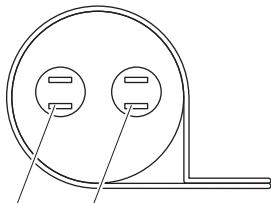
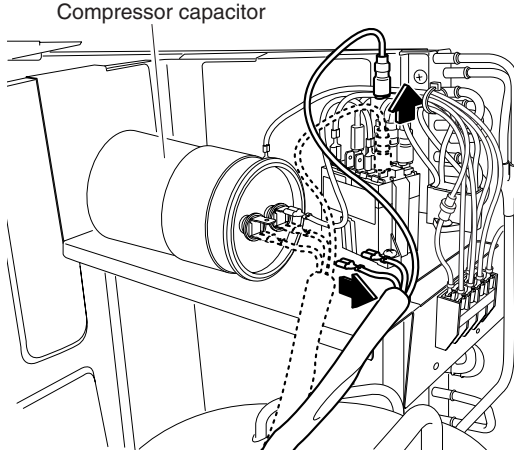
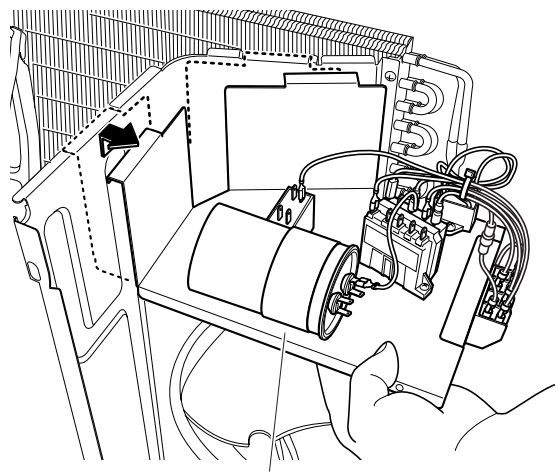
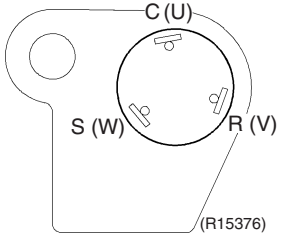
Step	Procedure	Points
2.	Remove the electrical component ASSY.	<ul style="list-style-type: none"> ■ Fan capacitor (C2R)
1	Pull out the 2 terminals from the fan capacitor (C2R).	<p>to fan motor: red</p>  <p>to fan motor: white</p> <p>(R17634)</p>
2	Pull out the terminal [5] from the magnetic contactor (K1M).	<ul style="list-style-type: none"> ■ Magnetic contactor (K1M)
3	Release the fan motor lead wire from the hook.	 <p>to fan motor: black</p> <p>(R17635)</p>
4	Pull out the terminal [1] from the magnetic contactor (K1M).	<ul style="list-style-type: none"> ■ Magnetic contactor (K1M)
5	Pull out the 2 terminals from the compressor capacitor (C1R).	 <p>to compressor: blue</p> <p>(R17636)</p>
6	Lift and remove the electrical component ASSY.	<ul style="list-style-type: none"> ■ Compressor capacitor (C1R)
	 <p>Fan capacitor</p> <p>Magnetic contactor</p> <p>Fan motor lead wire</p> <p>(R16343)</p>	 <p>to compressor (S terminal): yellow</p> <p>to compressor (R terminal): red</p> <p>(R17462)</p>
	 <p>Compressor capacitor</p> <p>(R16348)</p>	<ul style="list-style-type: none"> ■ Compressor lead wire
	 <p>Electrical component ASSY</p> <p>(R16350)</p>	 <p>S (W): yellow</p> <p>C (U): blue</p> <p>R (V): red</p> <p>(R15376)</p>

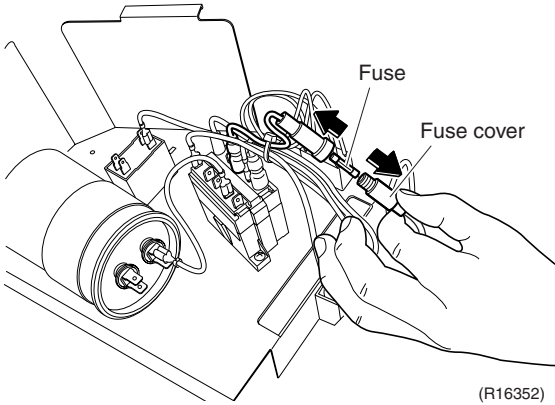
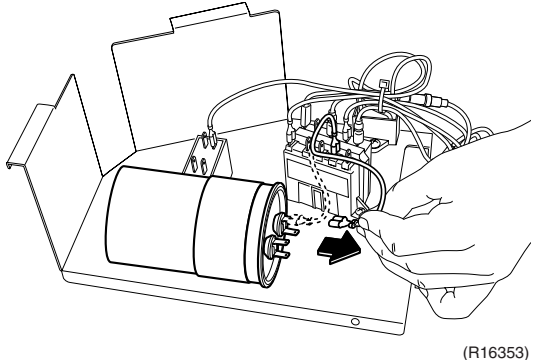
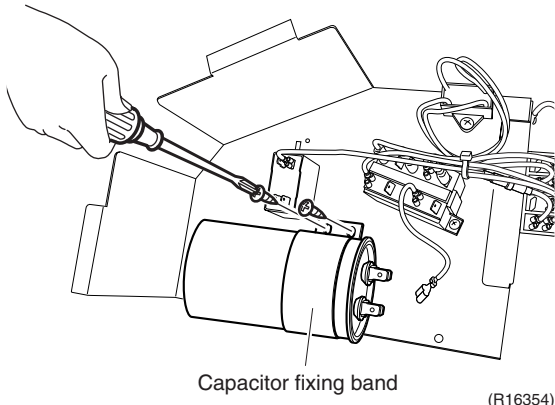
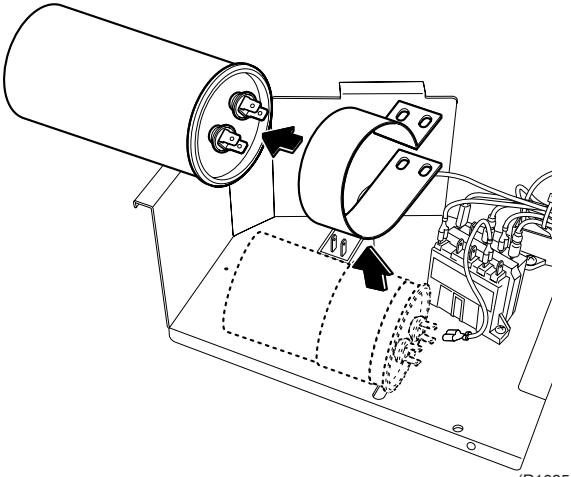
Step	Procedure	Points
3. Remove the electrical components.		
1 Open the fuse cover and remove the fuse.	 <p style="text-align: center;">(R16352)</p>	
2 Pull out the remaining terminal from the compressor capacitor (C1R).	 <p style="text-align: center;">(R16353)</p>	<p>■ Compressor capacitor (C1R) to magnetic contactor K1M(3): red</p> <p style="text-align: right;">(R16351)</p>
3 Remove the 2 screws of the capacitor fixing band.	 <p style="text-align: center;">(R16354)</p>	
4 Remove the compressor capacitor.	 <p style="text-align: center;">(R16355)</p>	

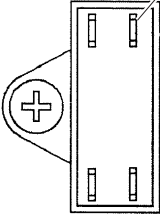
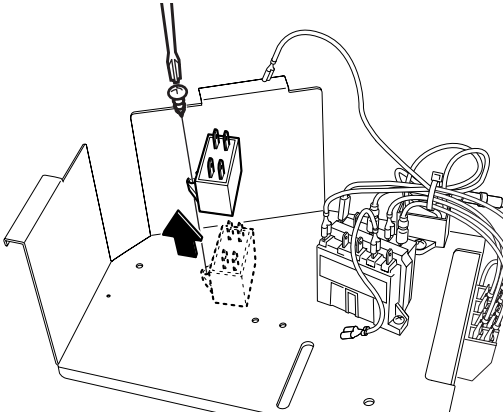
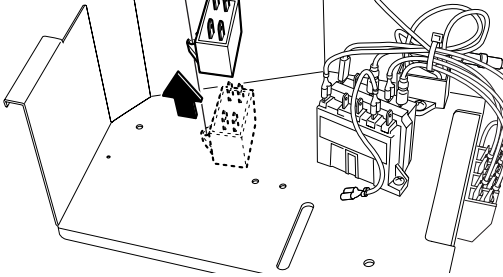
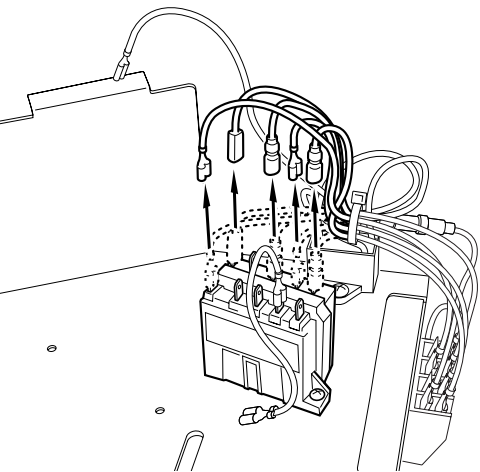
Step	Procedure	Points
5	Pull out the terminal from the fan capacitor (C2R).	<p>■ Fan capacitor (C2R) to terminal board X1M(3): red</p>  <p>(R16184)</p>
6	Remove the screw and remove the fan capacitor.	 <p>(R16356)</p>  <p>(R16357)</p>
7	Pull out the terminals [2] [4] [6] [A1] [A2] from the magnetic contactor (K1M).	 <p>(R16358)</p>

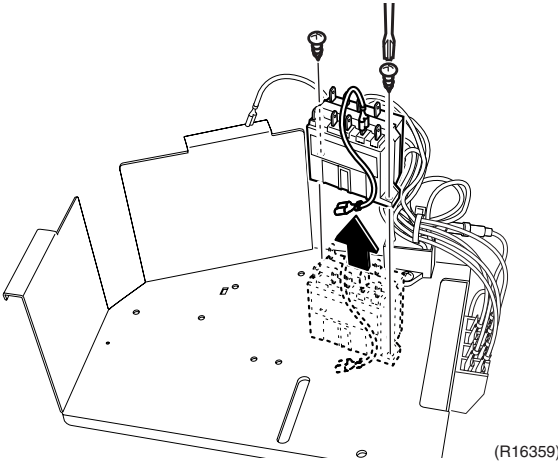
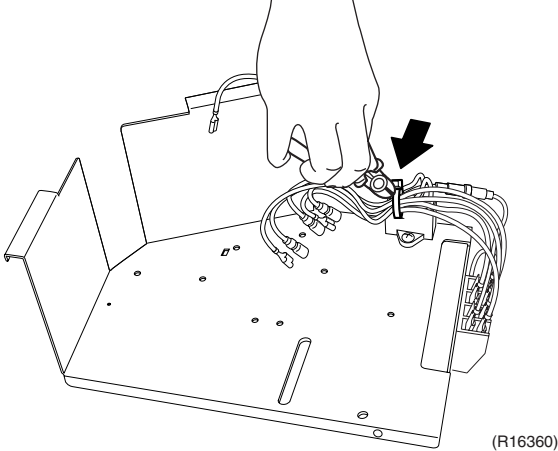
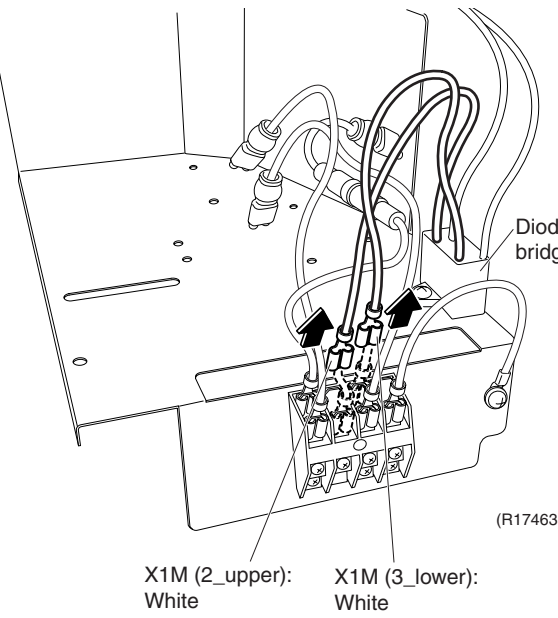
Step	Procedure	Points
8	Remove the 2 screws and remove the magnetic contactor.	
		
9	Cut the clamp.	
		
10	Pull out the 2 terminals for the diode bridge (V1R) from the terminal board.	
	 <p data-bbox="644 1805 794 1856">X1M (2_upper): White</p> <p data-bbox="836 1805 986 1856">X1M (3_lower): White</p>	

Step	Procedure	Points
11	Remove the screw and remove the diode bridge.	
12	Remove the screw of the earth wire and the screw of the terminal board.	
13	Remove the terminal board.	

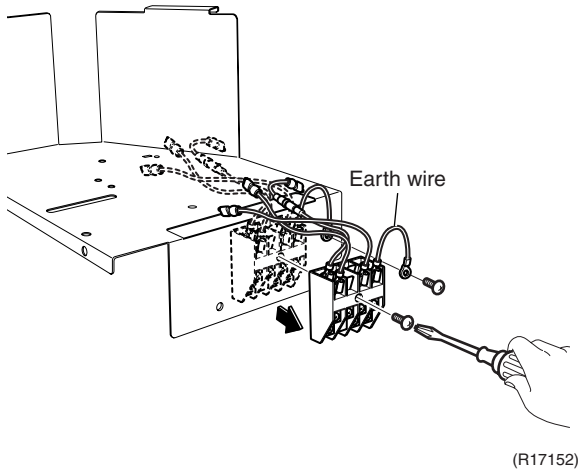
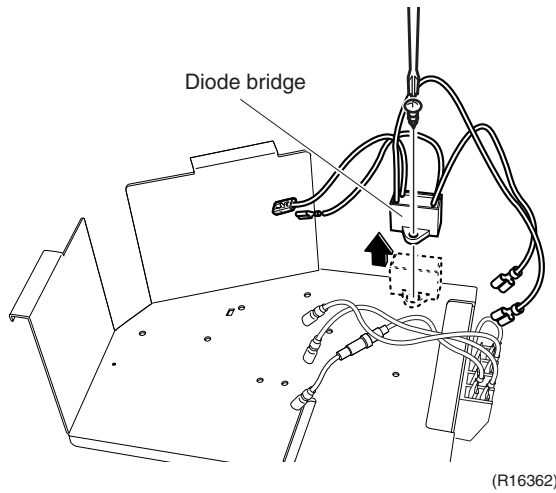

6. Removal of Sound Blankets

Procedure



Warning Be sure to wait for 10 minutes or more after turning off all power supplies before disassembling work.

Step	Procedure	Points
1	Remove the sound blanket (top).	<p>Preparation</p> <ul style="list-style-type: none"> ■ Remove the outer panels according to the “Removal of Outer Panels”. ■ Remove the electrical components ASSY according to the “Removal of Electrical Components”.
2	Remove the sound blanket (body).	<ul style="list-style-type: none"> ■ Since the piping ports on the sound blanket are torn easily, remove the sound blanket carefully.

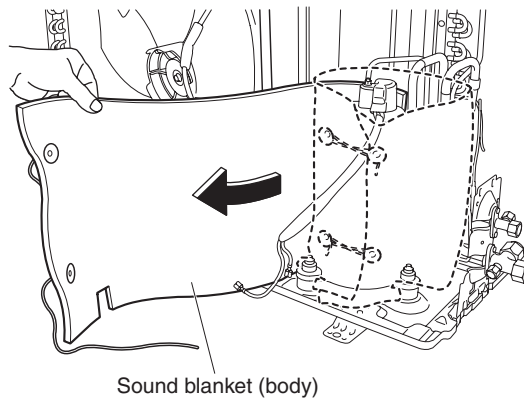
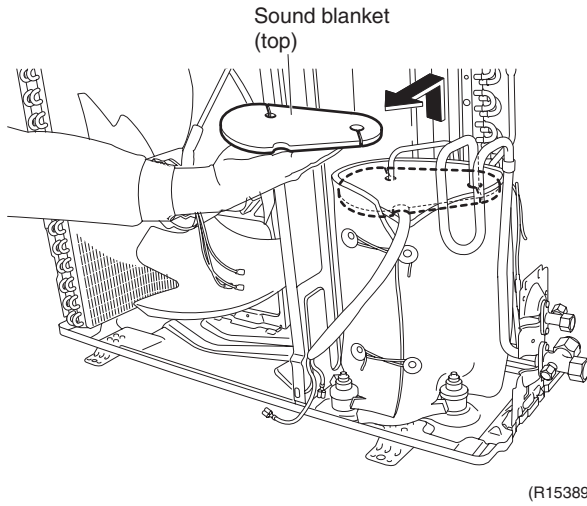

7. Removal of Capillary Tube (Pattern 1)

Procedure

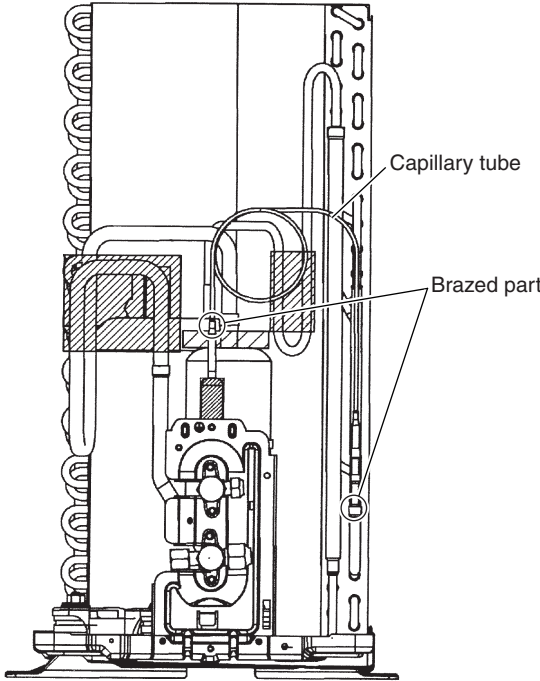
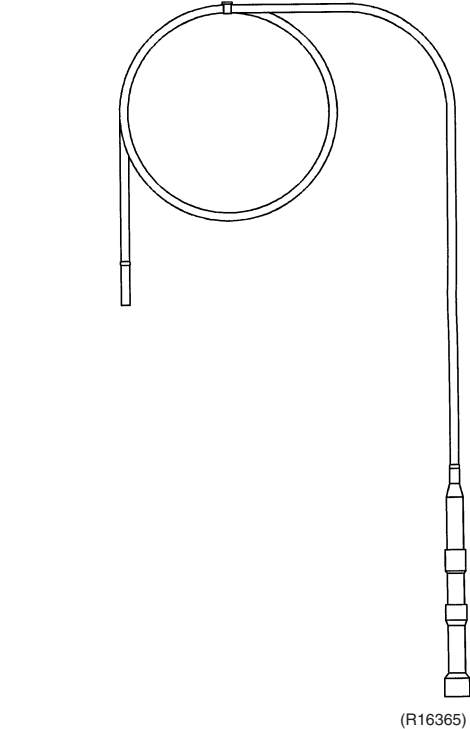

Warning Be sure to wait for 10 minutes or more after turning off all power supplies before disassembling work.

Step	Procedure	Points
<ul style="list-style-type: none"> ■ Before working, make sure that the refrigerant gas is empty in the circuit. ■ Be sure to apply nitrogen replacement when heating up the brazed part. 		<p>Warning Be careful not to get yourself burnt with the pipes and other parts that are heated by the gas brazing machine.</p> <p>Warning If the refrigerant gas leaks during work, ventilate the room. (If the refrigerant gas is exposed to flames, toxic gas may be generated.)</p> <p>Caution From the viewpoint of global environment protection, do not discharge the refrigerant gas in the atmosphere. Make sure to collect all the refrigerant gas.</p>
<p>1 Heat up the 2 brazed parts and remove the capillary tube.</p>		<p>Cautions for restoration</p> <ol style="list-style-type: none"> 1. Restore the piping by non-oxidation brazing. 2. Avoid excessive heating. (Keep below 120°C) <p>In case of difficulty with gas brazing machine</p> <ol style="list-style-type: none"> 1. Disconnect the brazed part where is easy to disconnect and restore. 2. Cut pipes on the main unit with a tube cutter in order to make it easy to disconnect.
<p>Note:</p> <ul style="list-style-type: none"> ■ Do not use a metal saw for cutting pipes by all means because the sawdust comes into the circuit. ■ When withdrawing the pipes, be careful not to pinch them firmly with pliers. The pipes may get deformed. ■ Provide a protective sheet or a steel plate so that the brazing flame cannot influence peripheries. ■ Be careful so as not to burn the compressor terminals, the name plate, the heat exchanger fin. 		

8. Removal of Capillary Tube (Pattern 2)

Procedure



Warning Be sure to wait for 10 minutes or more after turning off all power supplies before disassembling work.

Step	Procedure	Points
<ul style="list-style-type: none"> ■ Before working, make sure that the refrigerant gas is empty in the circuit. ■ Be sure to apply nitrogen replacement when heating up the brazed part. 	<p style="text-align: right;">Capillary tube</p> <p style="text-align: right;">Brazed part</p> <p style="text-align: right;">(R16844)</p>	<p>Warning Be careful not to get yourself burnt with the pipes and other parts that are heated by the gas brazing machine.</p>
<p>1 Heat up the 2 brazed parts and remove the capillary tube.</p>	<p style="text-align: right;">Brazed part</p> <p style="text-align: right;">(R17186)</p>	<p>Warning If the refrigerant gas leaks during work, ventilate the room. (If the refrigerant gas is exposed to flames, toxic gas may be generated.)</p>
<p>Note:</p> <ul style="list-style-type: none"> ■ Do not use a metal saw for cutting pipes by all means because the sawdust comes into the circuit. ■ When withdrawing the pipes, be careful not to pinch them firmly with pliers. The pipes may get deformed. ■ Provide a protective sheet or a steel plate so that the brazing flame cannot influence peripheries. ■ Be careful so as not to burn the compressor terminals, the name plate, the heat exchanger fin. 	<p style="text-align: center;">(R16833)</p>	<p>Caution From the viewpoint of global environment protection, do not discharge the refrigerant gas in the atmosphere. Make sure to collect all the refrigerant gas.</p>
		<p>Cautions for restoration</p> <ol style="list-style-type: none"> 1. Restore the piping by non-oxidation brazing. 2. Avoid excessive heating. (Keep below 120°C)
		<p>In case of difficulty with gas brazing machine</p> <ol style="list-style-type: none"> 1. Disconnect the brazed part where is easy to disconnect and restore. 2. Cut pipes on the main unit in order to make it easy to disconnect.

9. Removal of Compressor ASSY

Procedure



Warning Be sure to wait for 10 minutes or more after turning off all power supplies before disassembling work.

Step	Procedure	Points
1	Remove the nut.	
2	Remove the terminal cover.	
3	Disconnect the compressor lead wires.	<p>(R15376)</p>

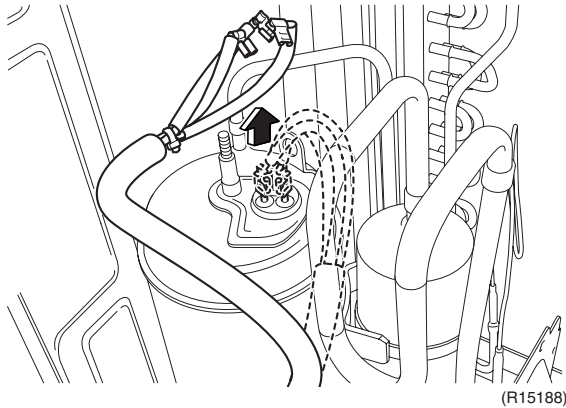
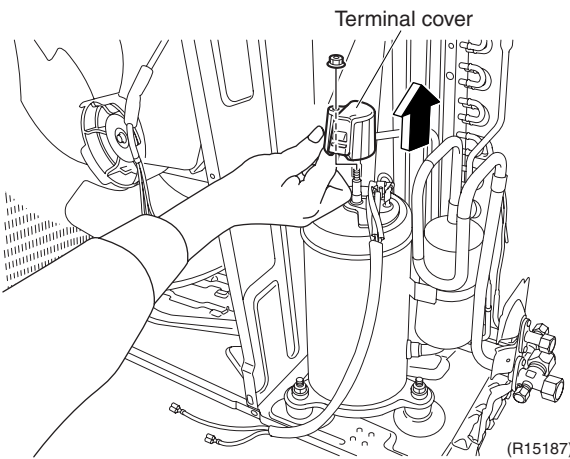
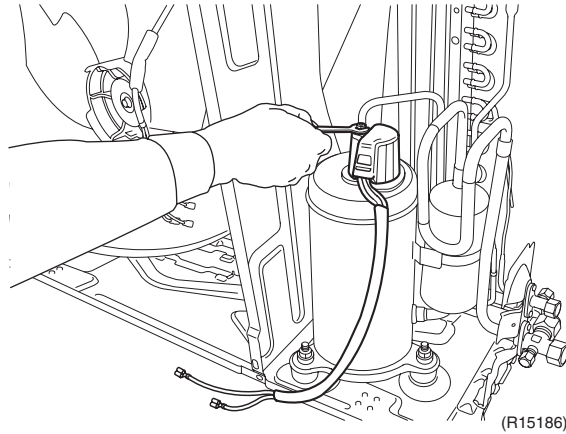

S (W): yellow
 C (U): blue
 R (V): red

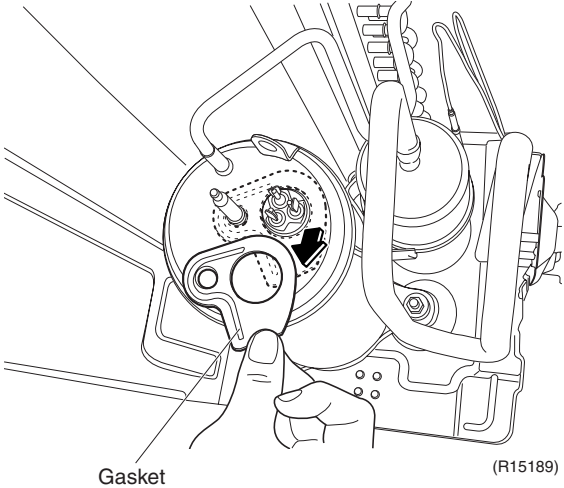
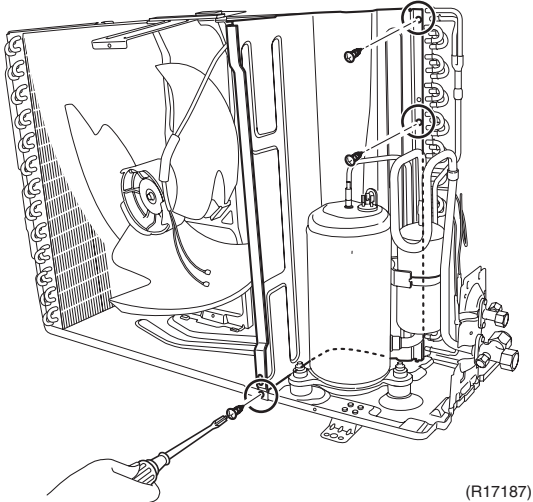
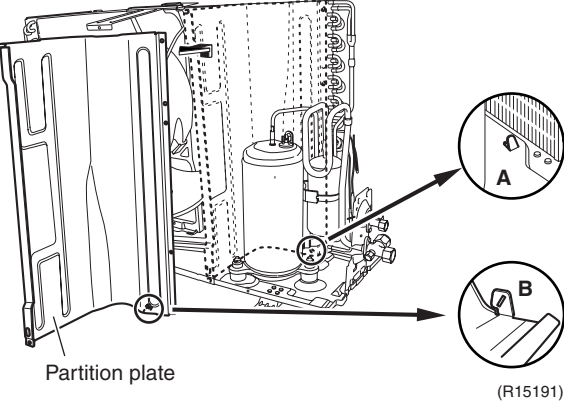
Step	Procedure	Points
4	Remove the gasket.	
	 <p>Gasket (R15189)</p>	
5	Remove the 3 screws of the partition plate.	
	 <p>(R17187)</p>	
6	Remove the partition plate.	<p>■ When reassembling, insert A into B.</p>
	 <p>Partition plate (R15191)</p>	

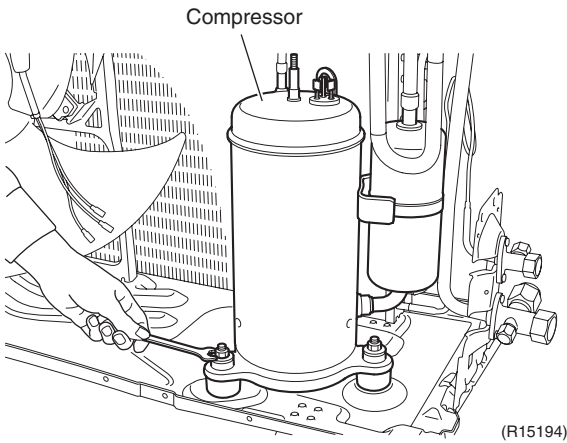
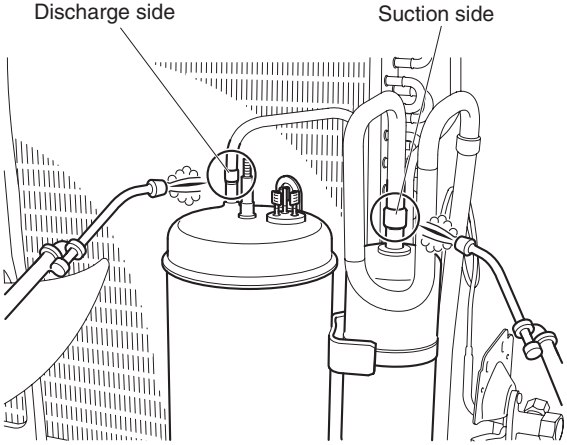
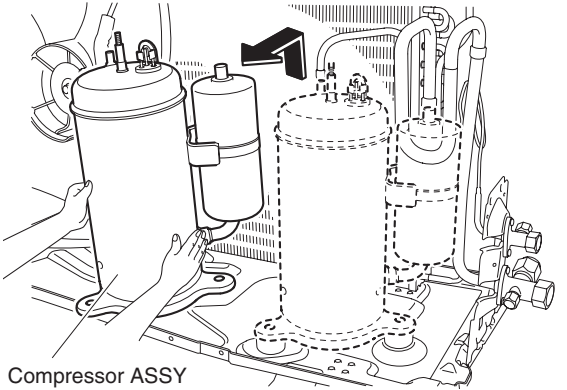
Step	Procedure	Points
7	Remove the 3 nuts of the compressor.	<p>Warning Be careful not to get yourself burnt with the pipes and other parts that are heated by the gas brazing machine.</p>
<ul style="list-style-type: none"> ■ Before working, make sure that the refrigerant gas is empty in the circuit. ■ Be sure to apply nitrogen replacement when heating up the brazed part. 	 <p style="text-align: right;">(R15194)</p>	<p>Warning If the refrigerant gas leaks during work, ventilate the room. (If the refrigerant gas is exposed to flames, toxic gas may be generated.)</p>
8	Heat up the brazed part of the discharge side and disconnect.	<p>Warning Since it may happen that the refrigerant oil in the compressor catches fire, prepare wet cloth so as to extinguish fire immediately.</p>
9	Heat up the brazed part of the suction side and disconnect.	<p>Caution From the viewpoint of global environment protection, do not discharge the refrigerant gas in the atmosphere. Make sure to collect all the refrigerant gas.</p>
10	Lift the compressor ASSY up and remove it.	<p>Cautions for restoration</p> <ol style="list-style-type: none"> 1. Restore the piping by non-oxidation brazing. 2. Avoid excessive heating. (Keep below 120°C) <p>In case of difficulty with gas brazing machine</p> <ol style="list-style-type: none"> 1. Disconnect the brazed part where is easy to disconnect and restore. 2. Cut pipes on the main unit with a tube cutter in order to make it easy to disconnect.
<p>Note:</p> <ul style="list-style-type: none"> ■ Do not use a metal saw for cutting pipes by all means because the sawdust comes into the circuit. ■ When withdrawing the pipes, be careful not to pinch them firmly with pliers. The pipes may get deformed. ■ Provide a protective sheet or a steel plate so that the brazing flame cannot influence peripheries. ■ Be careful so as not to burn the compressor terminals, the name plate, the heat exchanger fin. 	 <p style="text-align: right;">(R15195)</p>  <p style="text-align: right;">(R15196)</p>	

Revision History

Month / Year	Version	Revised contents
08/2012	Si011191	First edition

Warning



- Daikin products are manufactured for export to numerous countries throughout the world. Prior to purchase, please confirm with your local authorised importer, distributor and/or retailer whether this product conforms to the applicable standards, and is suitable for use, in the region where the product will be used. This statement does not purport to exclude, restrict or modify the application of any local legislation.
- Ask a qualified installer or contractor to install this product. Do not try to install the product yourself. Improper installation can result in water or refrigerant leakage, electrical shock, fire or explosion.
- Use only those parts and accessories supplied or specified by Daikin. Ask a qualified installer or contractor to install those parts and accessories. Use of unauthorised parts and accessories or improper installation of parts and accessories can result in water or refrigerant leakage, electrical shock, fire or explosion.
- Read the User's Manual carefully before using this product. The User's Manual provides important safety instructions and warnings. Be sure to follow these instructions and warnings.

If you have any enquiries, please contact your local importer, distributor and/or retailer.

Cautions on product corrosion

1. Air conditioners should not be installed in areas where corrosive gases, such as acid gas or alkaline gas, are produced.
2. If the outdoor unit is to be installed close to the sea shore, direct exposure to the sea breeze should be avoided. If you need to install the outdoor unit close to the sea shore, contact your local distributor.

Dealer

DAIKIN INDUSTRIES, LTD.

Head Office:
Umeda Center Bldg., 2-4-12, Nakazaki-Nishi,
Kita-ku, Osaka, 530-8323 Japan

Tokyo Office:
JR Shinagawa East Bldg., 2-18-1, Konan,
Minato-ku, Tokyo, 108-0075 Japan

http://www.daikin.com/global_ac/

©All rights reserved