



REMOVAL PROCEDURE



S E R V I C E M A N U A L

5.0 kW Class 18000 Btu/h Class

-  Outdoor Unit
-  Non-inverter
-  Pair Type



Service Manual Removal Procedure

Outdoor Unit

●Cooling Only

RE18KV2S

R50GV1G6

Table of Contents

1. Removal of Outer Panels	2
2. Removal of Fan Motor / Outdoor Fan	5
3. Removal of Sound Blankets.....	7
4. Removal of Electrical Components ASSY	9
5. Removal of Compressor	11



Note: ♦ The illustrations may be slightly different depending on the model.

1. Removal of Outer Panels

Procedure



Warning Be sure to wait 10 minutes or more after turning off all power supplies before disassembling work.

Step	Procedure	Points
1	Remove the 4 screws and remove the top panel.	<ul style="list-style-type: none"> Take care not to cut your finger by the fins of the outdoor heat exchanger.
2	Remove the 4 screws and remove the discharge grille.	

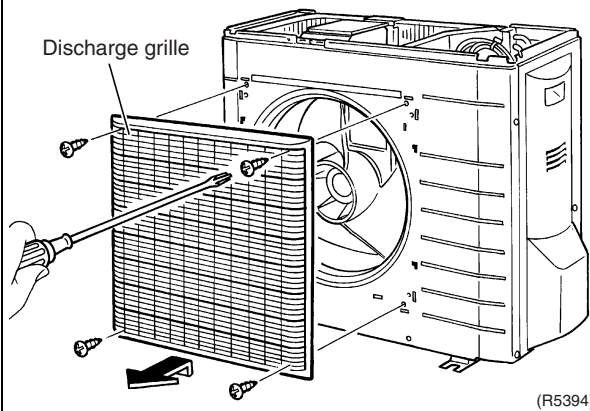
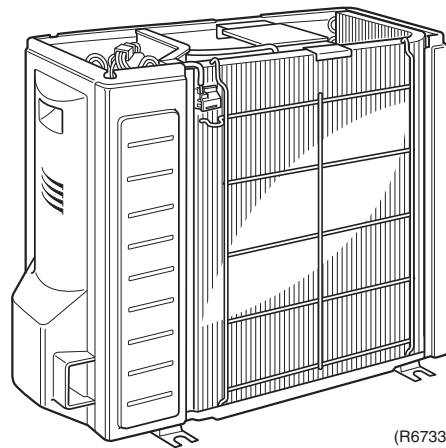
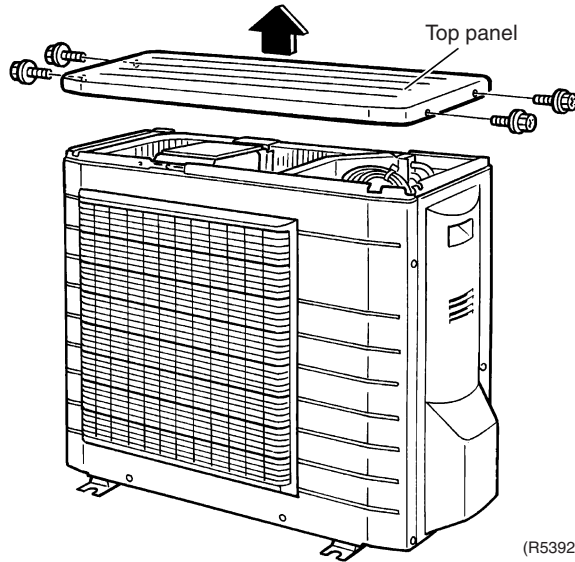

Step	Procedure	Points
3	Remove the 6 screws of the front panel.	
4	Unfasten the center hooks in the order of ① to ②.	
5	Lift the left side of the front panel and unfasten the 3 hooks.	

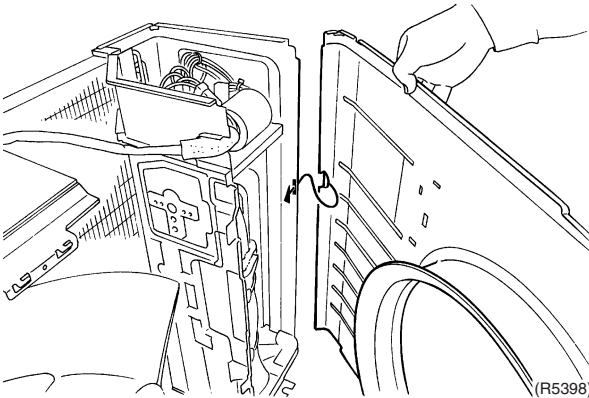
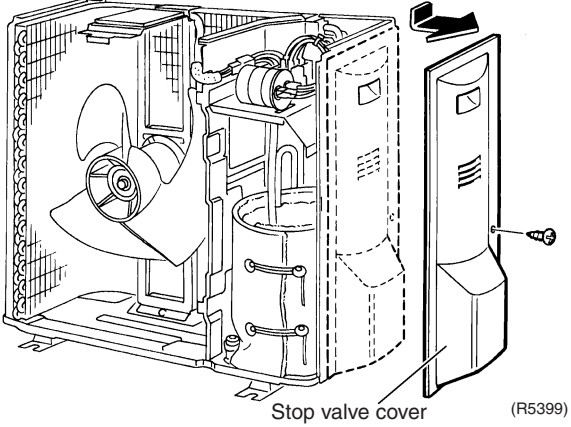
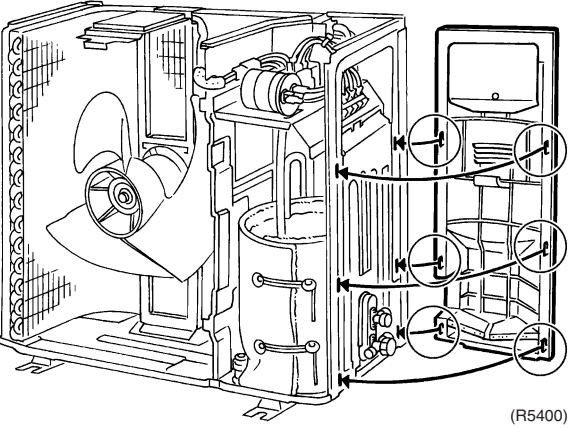
Step	Procedure	Points
6	Unfasten the hook on the right side and remove the front panel.	
	 <p>(R5398)</p>	
7	Remove the screw and remove the stop valve cover.	
	 <p>Stop valve cover (R5399)</p>	
	 <p>(R5400)</p>	<p>■ The stop valve cover has 6 hooks.</p>

2. Removal of Fan Motor / Outdoor Fan

Procedure



Warning

Be sure to wait 10 minutes or more after turning off all power supplies before disassembling work.

Step	Procedure	Points
1	Disconnect the relay connector for the fan motor.	(R5401)
2	Remove the 2 screws of the fan motor fixing plate.	(R5402)
3	Lift up and remove the fan motor fixing plate.	<ul style="list-style-type: none"> ■ Be careful so as not to damage the top part of the outdoor heat exchanger fins.

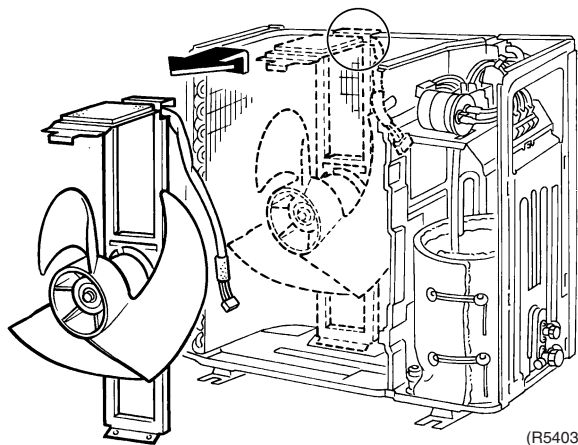
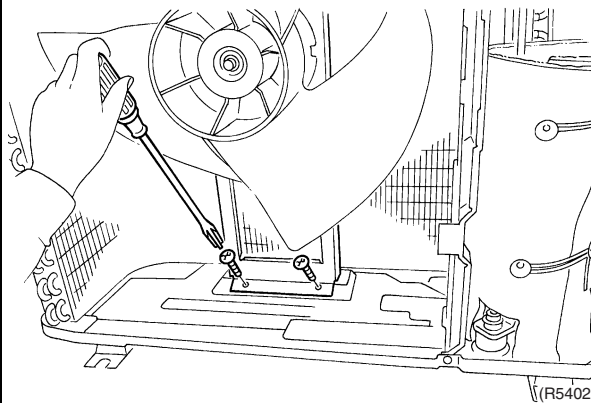
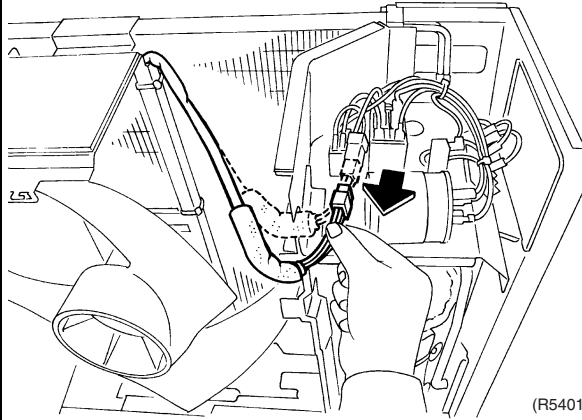

Step	Procedure	Points
4	Cut the 3 clamps and release the fan motor lead wire.	<ul style="list-style-type: none"> Put the fan motor lead wire through the back of the fan motor when reassembling so as not to be entangled with the outdoor fan.
5	Remove the nut and remove the outdoor fan.	<ul style="list-style-type: none"> Nut size: M6 <p>10 mm</p> <ul style="list-style-type: none"> When reassembling, align the ▼ mark of the outdoor fan with the D-cut section of the motor shaft.
6	Remove the 4 screws and remove the fan motor.	

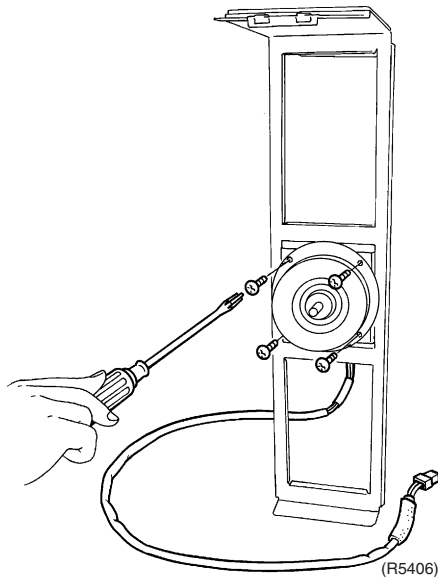
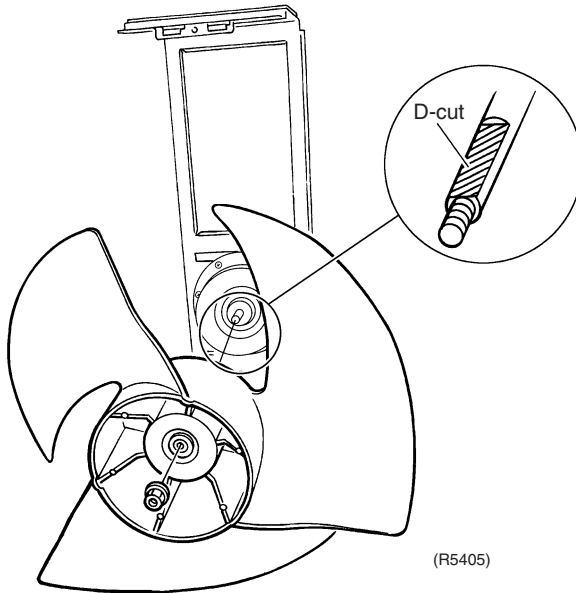
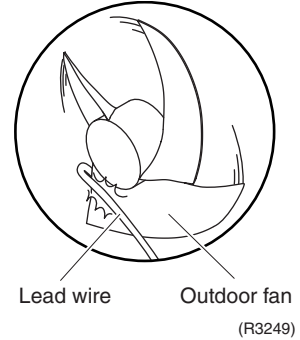
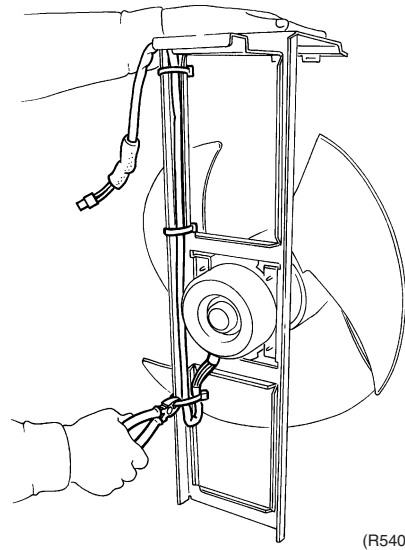

3. Removal of Sound Blankets

Procedure

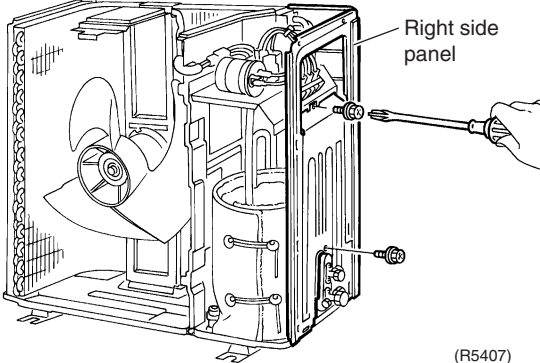
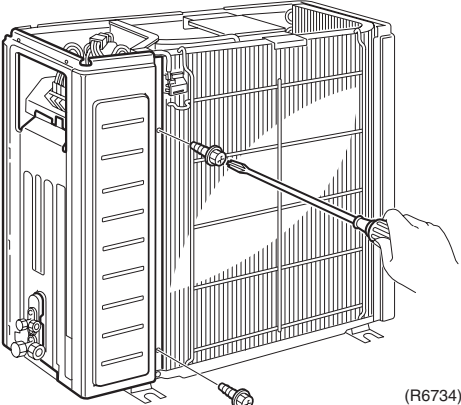
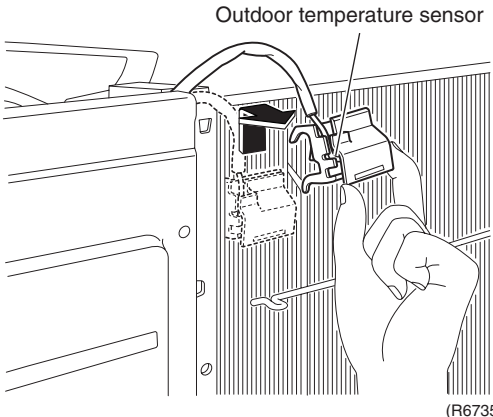
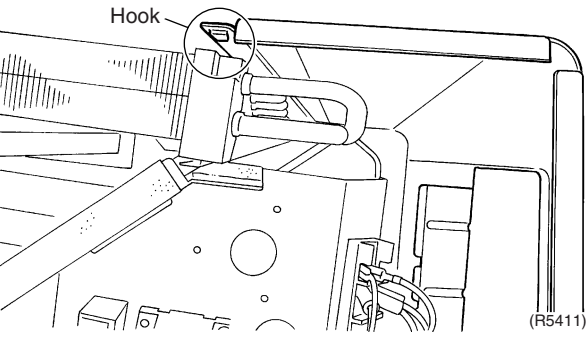

Warning Be sure to wait 10 minutes or more after turning off all power supplies before disassembling work.

Step	Procedure	Points
1. Remove the right side panel.	 <p>Right side panel</p> <p>(R5407)</p>	
1 Remove the 4 screws.	 <p>(R6734)</p>	
2 Detach the outdoor temperature sensor.	 <p>Outdoor temperature sensor</p> <p>(R6735)</p>	
3 Unfasten the hook at the rear side.	 <p>Hook</p> <p>(R5411)</p>	

Step	Procedure	Points
4	Lift up and remove the right side panel.	<ul style="list-style-type: none"> ■ When reassembling, fit the 2 lower hooks.
2. Remove the sound blankets.		
1	Remove the sound blanket (top).	
2	Remove the sound blanket (body).	

4. Removal of Electrical Components ASSY

Procedure

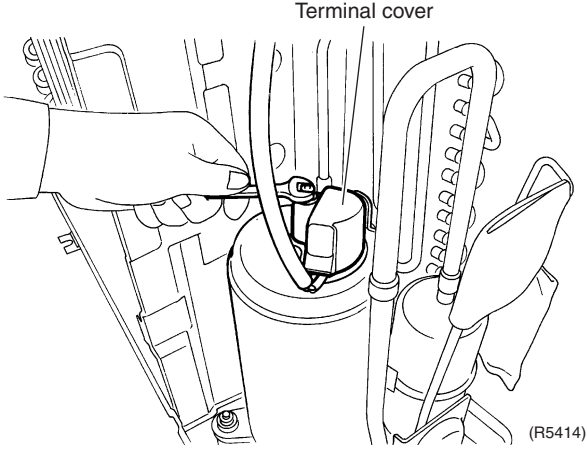
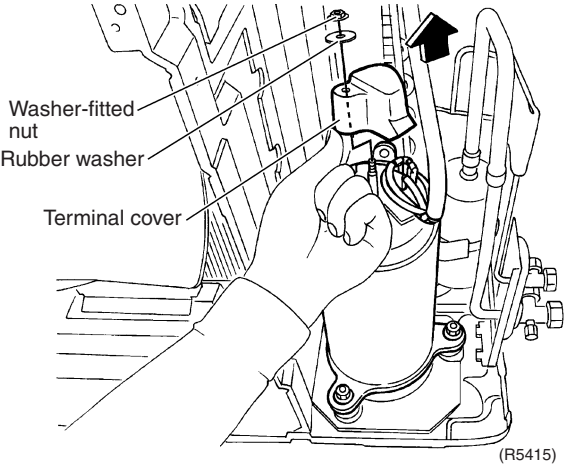
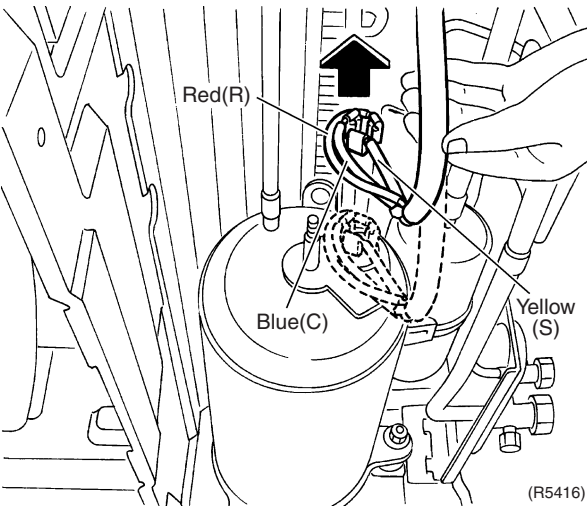

Warning Be sure to wait 10 minutes or more after turning off all power supplies before disassembling work.

Step	Procedure	Points
1	Remove the nut and remove the terminal cover.	 <p>Terminal cover</p> <p>(R5414)</p>  <p>Washer-fitted nut</p> <p>Rubber washer</p> <p>Terminal cover</p> <p>(R5415)</p>
2	Disconnect the compressor lead wires.	 <p>Red(R)</p> <p>Blue(C)</p> <p>Yellow(S)</p> <p>(R5416)</p>

■ Be careful so as not to burn the compressor terminals or the name plate.

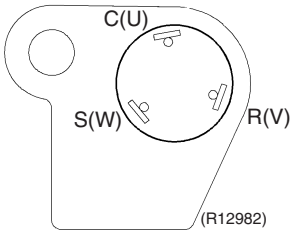
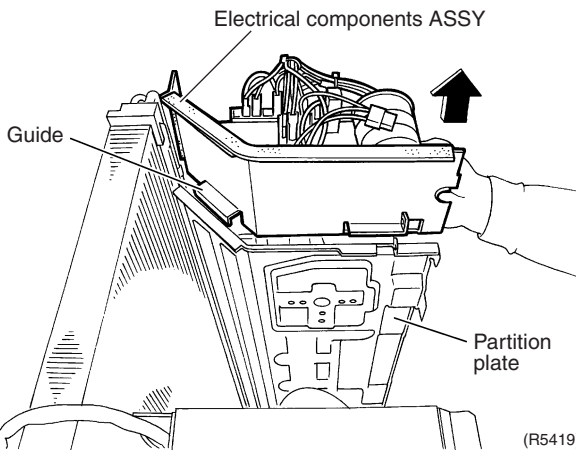
Step	Procedure	Points
3	Remove the gasket.	 <p>C(U) S(W) R(V) R12982</p>
4	Remove the screw of the electrical components ASSY.	<p>S(W) : Yellow C(U) : Blue R(V) : Red</p>
5	Lift up the electrical components ASSY and unfasten the guide for the partition plate. Remove the electrical components ASSY.	 <p>Electrical components ASSY Guide Partition plate R5419</p>

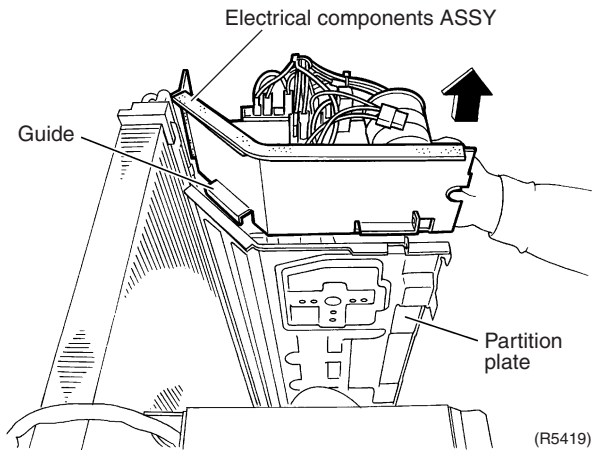
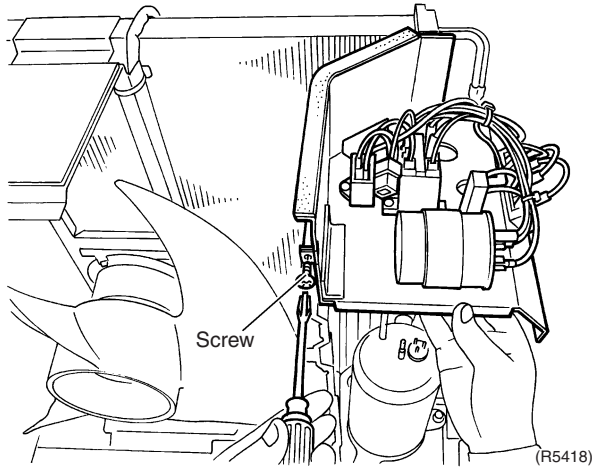
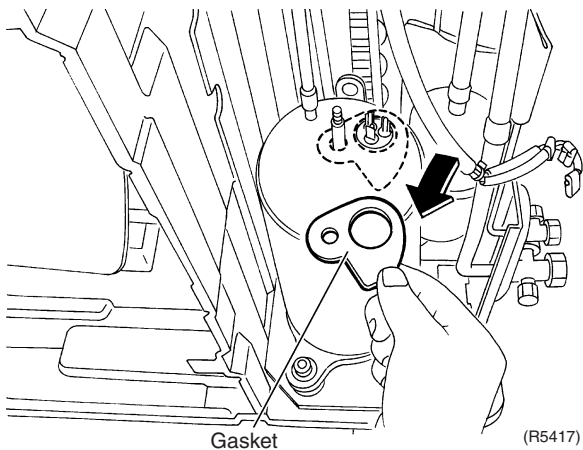







5. Removal of Compressor

Procedure

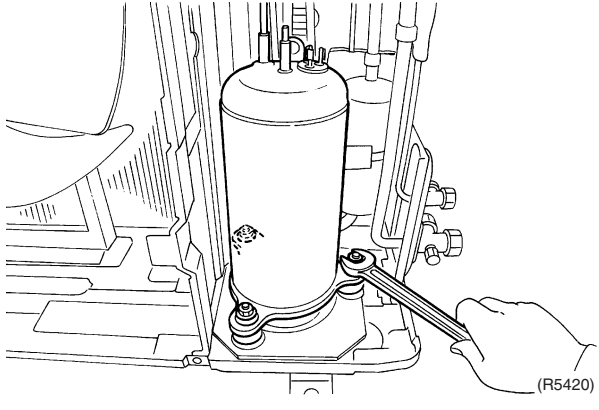

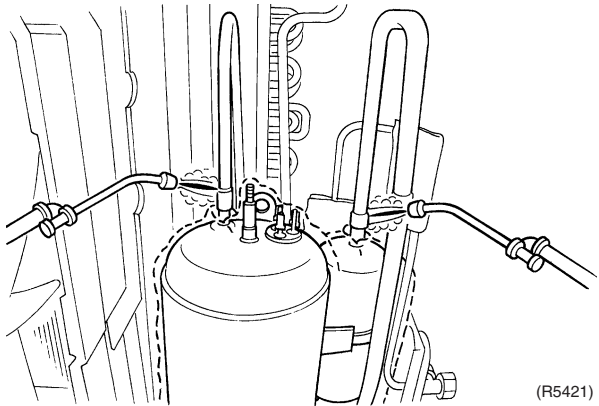
Warning

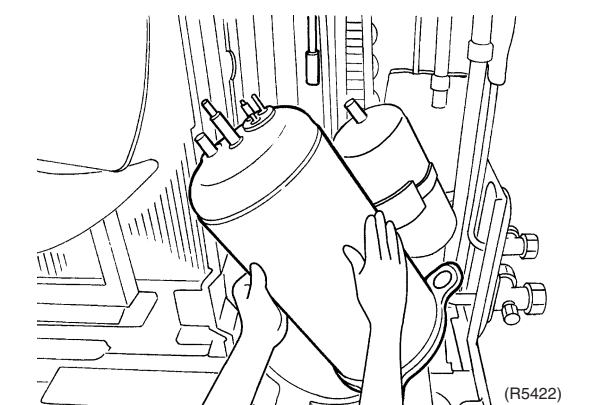
Be sure to wait 10 minutes or more after turning off all power supplies before disassembling work.

Step	Procedure	Points
1	Remove the 3 nuts of the compressor.	 Warning Be careful not to get yourself burnt with the pipes and other parts that are heated by the gas brazing machine.
<ul style="list-style-type: none"> ■ Before working, make sure that the refrigerant is empty in the circuit. ■ Be sure to apply nitrogen replacement when heating up the brazed part. 	 <p style="text-align: right;">(R5420)</p>	 Warning If the refrigerant gas leaks during work, ventilate the room. (If the refrigerant gas is exposed to flames, toxic gas may be generated.)
2 Heat up the brazed part of the discharge side and disconnect. 3 Heat up the brazed part of the suction side and disconnect. 4 Lift the compressor up and remove it.	 <p style="text-align: right;">(R5421)</p>	 Warning Since it may happen that the refrigerant oil in the compressor catches fire, prepare wet cloth so as to extinguish fire immediately.
Note: <ul style="list-style-type: none"> ■ Do not use a metal saw for cutting pipes by all means because the sawdust comes into the circuit. ■ When withdrawing the pipes, be careful not to pinch them firmly with pliers. The pipes may get deformed. ■ Provide a protective sheet or a steel plate so that the brazing flame cannot influence peripheries. ■ Be careful so as not to burn the compressor terminals, the name plate, the heat exchanger fin. 	 <p style="text-align: right;">(R5422)</p>	 Caution From the viewpoint of global environment protection, do not discharge the refrigerant gas in the atmosphere. Make sure to collect all the refrigerant gas.
		Cautions for restoration <ol style="list-style-type: none"> 1. Restore the piping by non-oxidation brazing. 2. It is required to prevent the carbonization of the oil inside the four way valve and the deterioration of the gaskets affected by heat. (Keep below 120°C.) For the sake of this, wrap the four way valve with wet cloth and provide water so that the cloth does not dry. In case of difficulty with gas brazing machine <ol style="list-style-type: none"> 1. Disconnect the brazed part where is easy to disconnect and restore. 2. Cut pipes on the main unit with a tube cutter in order to make it easy to disconnect.

Revision History

Month / Year	Version	Revised contents
01 / 2013	Si011085	First edition

Warning



- Daikin products are manufactured for export to numerous countries throughout the world. Prior to purchase, please confirm with your local authorised importer, distributor and/or retailer whether this product conforms to the applicable standards, and is suitable for use, in the region where the product will be used. This statement does not purport to exclude, restrict or modify the application of any local legislation.
- Ask a qualified installer or contractor to install this product. Do not try to install the product yourself. Improper installation can result in water or refrigerant leakage, electrical shock, fire or explosion.
- Use only those parts and accessories supplied or specified by Daikin. Ask a qualified installer or contractor to install those parts and accessories. Use of unauthorised parts and accessories or improper installation of parts and accessories can result in water or refrigerant leakage, electrical shock, fire or explosion.
- Read the User's Manual carefully before using this product. The User's Manual provides important safety instructions and warnings. Be sure to follow these instructions and warnings.

If you have any enquiries, please contact your local importer, distributor and/or retailer.

Cautions on product corrosion

1. Air conditioners should not be installed in areas where corrosive gases, such as acid gas or alkaline gas, are produced.
2. If the outdoor unit is to be installed close to the sea shore, direct exposure to the sea breeze should be avoided. If you need to install the outdoor unit close to the sea shore, contact your local distributor.

Dealer

DAIKIN INDUSTRIES, LTD.

Head Office:
Umeda Center Bldg., 2-4-12, Nakazaki-Nishi,
Kita-ku, Osaka, 530-8323 Japan

Tokyo Office:
JR Shinagawa East Bldg., 2-18-1, Konan,
Minato-ku, Tokyo, 108-0075 Japan

http://www.daikin.com/global_ac/

©All rights reserved