



REMOVAL PROCEDURE



SERVICE
MANUAL

S E R V I C E M A N U A L

2.5/3.5 kW Class

-  Outdoor Unit
-  Non-inverter
-  Pair Type

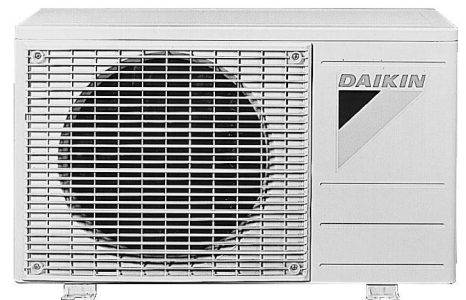

Service Manual Removal Procedure

Outdoor Unit

●Cooling Only

RWN25JV1

RWN35JV1

Table of Contents

1. Removal of Outer Panel.....	2
2. Removal of Electrical Component ASSY	3
3. Removal of Outdoor Fan / Fan Motor	6
4. Removal of Partition Plate.....	7
5. Removal of Compressor	8



Note: ♦ The illustrations may be slightly different depending on the model.

1. Removal of Outer Panel

Procedure



Warning Be sure to wait 10 minutes or more after turning off all power supplies before disassembling work.

Step	Procedure	Points
1	Remove the 3 screws and remove the top panel.	
2	Remove the 2 screws of the discharge grille.	
3	Unfasten the each 2 hooks at part A, part B, part C. Slide the discharge grille to the direction shown by the arrow and remove it.	
4	Remove the 6 screws and remove the front panel.	

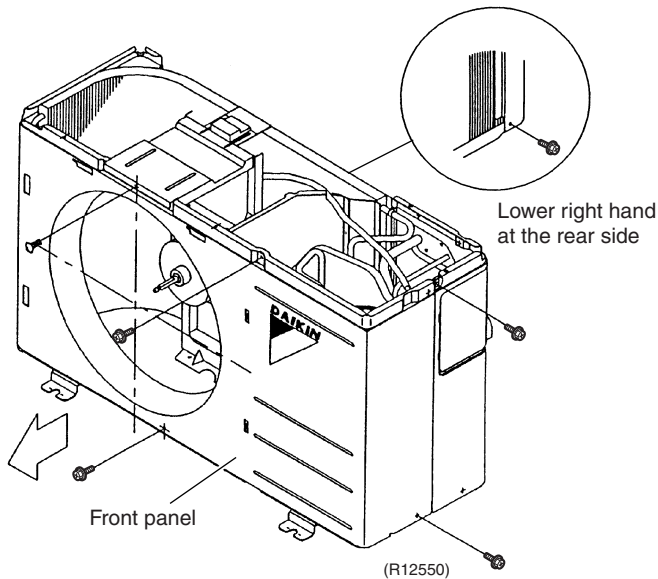
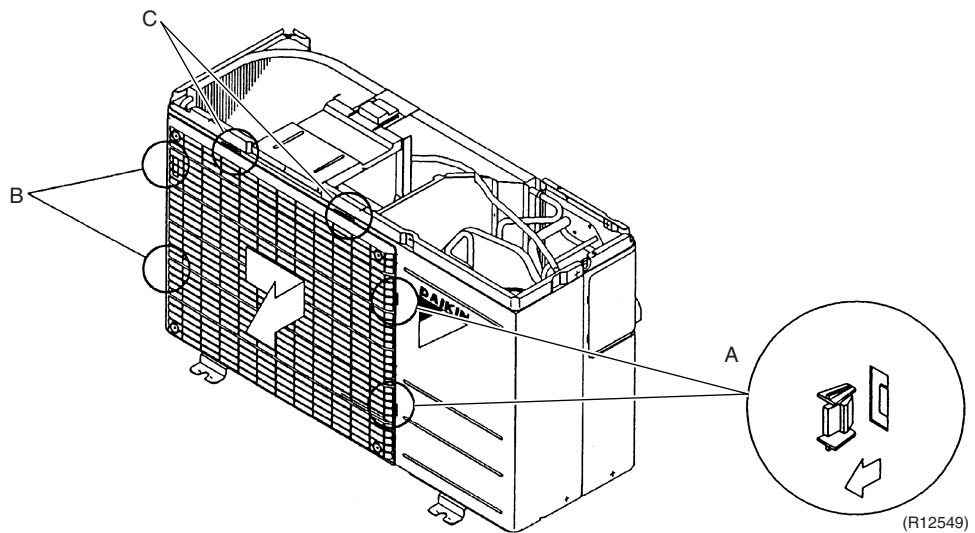
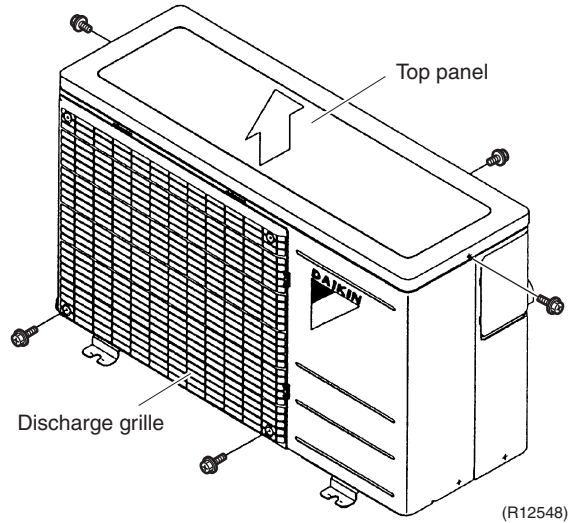

2. Removal of Electrical Component ASSY

Procedure



Warning Be sure to wait 10 minutes or more after turning off all power supplies before disassembling work.

Step	Procedure	Points
In case of service work without top panel		
1	Remove the screw and remove the service cover.	
<p>Service cover (R12730)</p>		
2	Remove the 2 screws of the electrical component ASSY.	
<p>(R12553)</p>		
3	Lift up and remove the electrical component ASSY.	
<p>Electrical component ASSY (R12551)</p>		
4	Cut the clamp and disconnect the 3 connectors for the fan motor lead wire.	
<p>Fan motor lead wire (Red) Clamp Fan motor lead wire (Black) Fan motor lead wire (White) (R12552)</p>		<p>(R12738)</p>

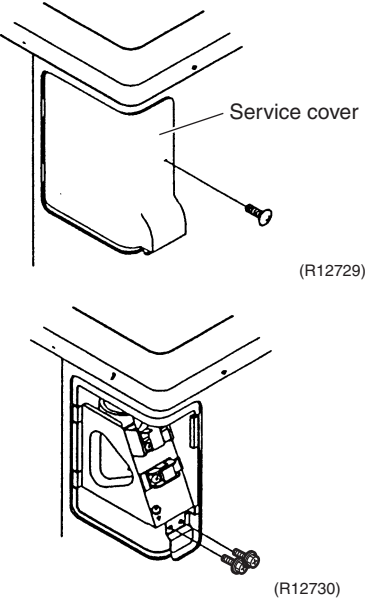
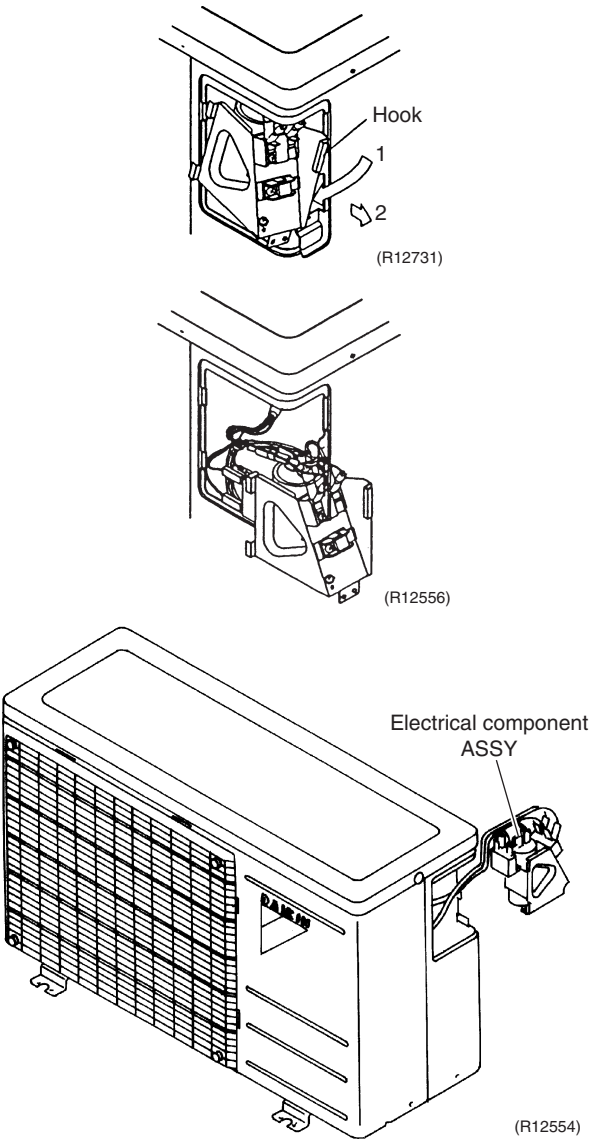
Step	Procedure	Points
<p>In case of service work with top panel</p> <p>1 Remove the screw and remove the service cover.</p> <p>2 Remove the 2 screws of the electrical component ASSY.</p>	 <p>Service cover</p> <p>(R12729)</p> <p>(R12730)</p>	
<p>1. Remove the electrical component ASSY.</p> <p>1 Unfasten the hook as shown with arrow 1 in the illustration.</p> <p>2 Pull out the electrical component ASSY as shown with arrow 2 in the illustration.</p>	 <p>Hook</p> <p>1</p> <p>2</p> <p>(R12731)</p> <p>(R12556)</p> <p>Electrical component ASSY</p> <p>(R12554)</p>	

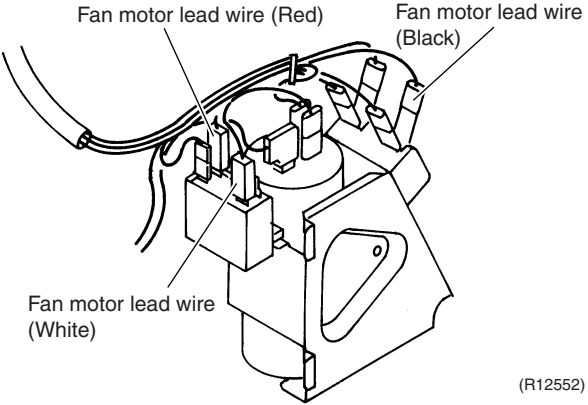
Step	Procedure	Points
2.	Disconnect the fan motor lead wires.	
1	<p data-bbox="199 286 475 414">Cut the clamp and disconnect the 3 connectors for the fan motor lead wire.</p>  <p data-bbox="1005 667 1077 689">(R12552)</p>	

3. Removal of Outdoor Fan / Fan Motor

Procedure



Warning Be sure to wait 10 minutes or more after turning off all power supplies before disassembling work.

Step	Procedure	Points
<p>1 Remove the washer-fitted nut and remove the outdoor fan.</p> <p>2 Remove the 2 screws and remove the fan motor fixing frame.</p>	<p style="text-align: right;">(R12557)</p>	<p>■ Nut size: M6</p> <p style="text-align: right;">(R12236)</p> <p>■ When reassembling, align the ▼ mark of the outdoor fan with the D-cut section of the motor shaft.</p>
<p>3 Remove the 2 screws and remove the fan motor.</p> <p>4 Cut the 3 clamps and release the fan motor lead wire.</p>	<p style="text-align: right;">(R12558)</p>	
<p>5 Cut the clamp and disconnect the connectors for the fan motor lead wire.</p>	<p style="text-align: right;">(R12552)</p>	

4. Removal of Partition Plate

Procedure



Warning Be sure to wait 10 minutes or more after turning off all power supplies before disassembling work.

Step	Procedure	Points
1	Remove the 2 screws of the partition plate.	
2	Unfasten the hooks of the bottom frame and remove the partition plate.	

5. Removal of Compressor

Procedure



Warning Be sure to wait 10 minutes or more after turning off all power supplies before disassembling work.

Step	Procedure	Points
<ul style="list-style-type: none">■ Before working, make sure that the refrigerant is empty in the circuit.■ Be sure to apply nitrogen replacement when heating up the brazed part.		
1 Remove the sound blankets.		
2 Disconnect the compressor wire harnesses.		

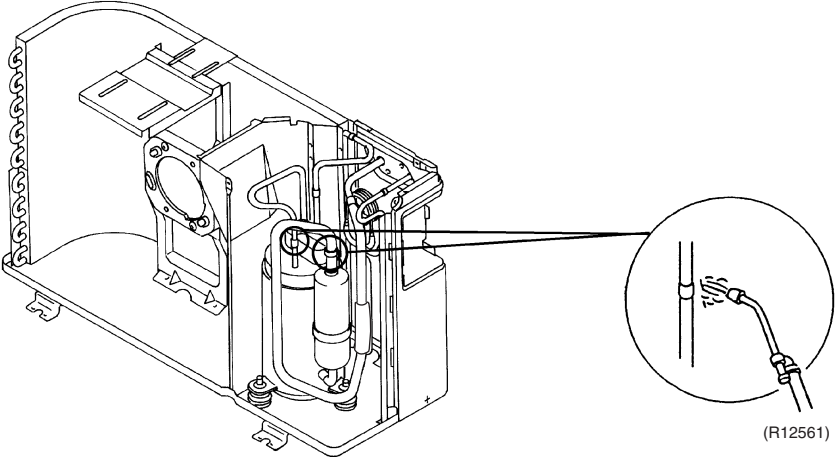
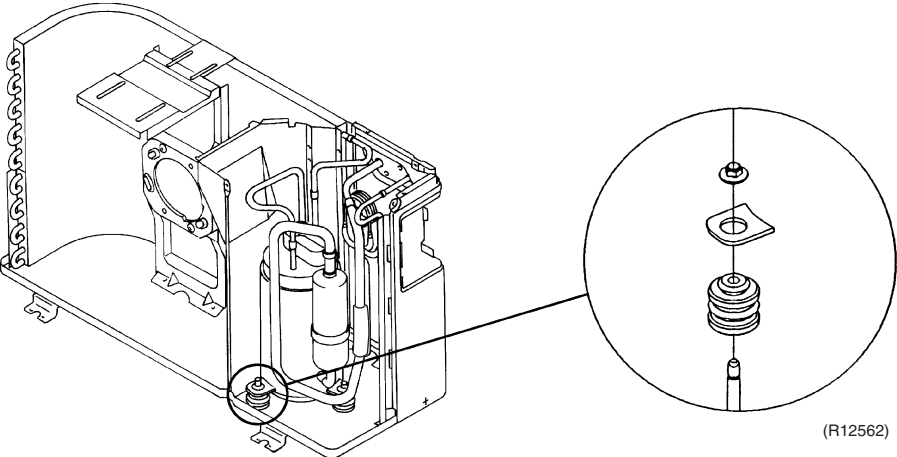
Step	Procedure	Points
3	Heat up the 2 brazed parts and disconnect them.	 <p>(R12561)</p>
4	Remove the 3 nuts and remove the compressor.	 <p>(R12562)</p>

Revision History

Month / Year	Version	Revised contents
01 / 2013	Si011082	First edition

Warning



- Daikin products are manufactured for export to numerous countries throughout the world. Prior to purchase, please confirm with your local authorised importer, distributor and/or retailer whether this product conforms to the applicable standards, and is suitable for use, in the region where the product will be used. This statement does not purport to exclude, restrict or modify the application of any local legislation.
- Ask a qualified installer or contractor to install this product. Do not try to install the product yourself. Improper installation can result in water or refrigerant leakage, electrical shock, fire or explosion.
- Use only those parts and accessories supplied or specified by Daikin. Ask a qualified installer or contractor to install those parts and accessories. Use of unauthorised parts and accessories or improper installation of parts and accessories can result in water or refrigerant leakage, electrical shock, fire or explosion.
- Read the User's Manual carefully before using this product. The User's Manual provides important safety instructions and warnings. Be sure to follow these instructions and warnings.

If you have any enquiries, please contact your local importer, distributor and/or retailer.

Cautions on product corrosion

1. Air conditioners should not be installed in areas where corrosive gases, such as acid gas or alkaline gas, are produced.
2. If the outdoor unit is to be installed close to the sea shore, direct exposure to the sea breeze should be avoided. If you need to install the outdoor unit close to the sea shore, contact your local distributor.

Dealer

DAIKIN INDUSTRIES, LTD.

Head Office:
Umeda Center Bldg., 2-4-12, Nakazaki-Nishi,
Kita-ku, Osaka, 530-8323 Japan

Tokyo Office:
JR Shinagawa East Bldg., 2-18-1, Konan,
Minato-ku, Tokyo, 108-0075 Japan

http://www.daikin.com/global_ac/

©All rights reserved