



REMOVAL PROCEDURE



SERVICE
MANUAL

S E R V I C E M A N U A L

2.5/3.5 kW Class

-  Outdoor Unit
-  Non-Inverter
-  Pair Type



Service Manual Removal Procedure

Outdoor Unit

●Cooling Only

RE25KV16

RE35KV16

Table of Contents

1. Removal of Outer Panels	2
2. Removal of Bellmouth	4
3. Removal of Electrical Components ASSY	5
4. Removal of Outdoor Fan / Fan Motor	6
5. Removal of Sound Blanket.....	8
6. Removal of Partition Plate.....	9
7. Removal of Compressor	10



Note: ♦ The illustrations may be slightly different depending on the model.

1. Removal of Outer Panels

Procedure



Warning Be sure to wait 10 minutes or more after turning off all power supplies before disassembling work.

Step	Procedure	Points
1	Remove the screw and remove the stop valve cover.	
2	The top panel and the front panel are constructed in a monoblock. Remove the 3 screws at the right side and the 2 screws at the front side.	
3	Remove the 3 screws at the left side.	

(R1847)

- As the stop valve cover has 3 hooks, slide the cover downward to remove.

Step	Procedure	Points
4	Remove the screw at the rear of the top panel. Once lift the panel ASSY and then remove it forward.	<ul style="list-style-type: none"> ■ The left side plate and the bellmouth can be removed all at once. ■ When restoring the panel ASSY, move it horizontally and get it down for the easy work.
5	Remove the screw and remove the left side panel.	<ul style="list-style-type: none"> ■ Sectional view

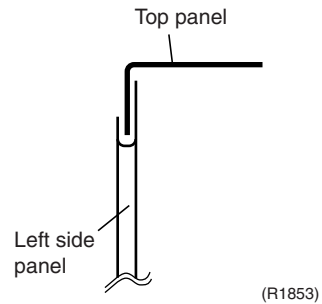
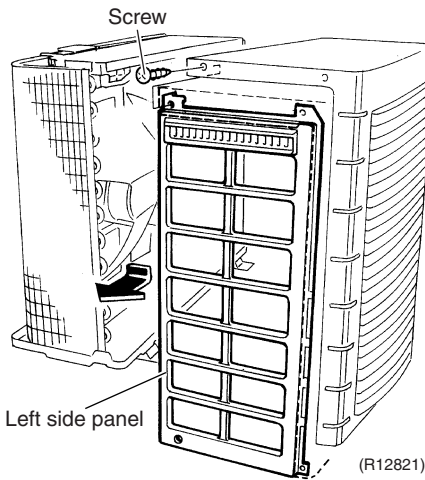
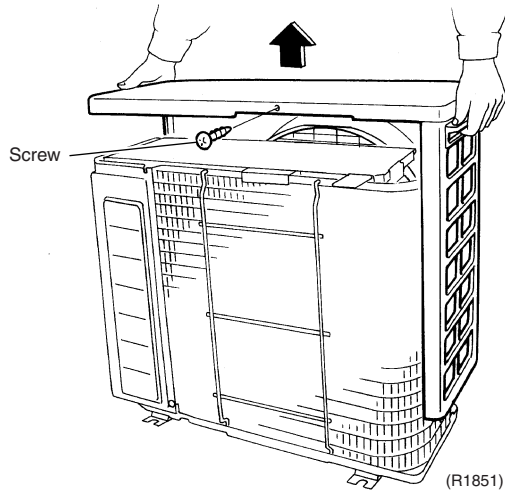

2. Removal of Bellmouth

Procedure



Warning Be sure to wait 10 minutes or more after turning off all power supplies before disassembling work.

Step	Procedure	Points
1	The bellmouth is attached with 2 screws and 4 hooks.	
	<p>(R1854)</p>	
2	Remove the 2 screws and slide the bellmouth in the arrow direction to disengage the hook B. Remove the bellmouth.	
	<p>(R12796)</p>	

3. Removal of Electrical Components ASSY

Procedure

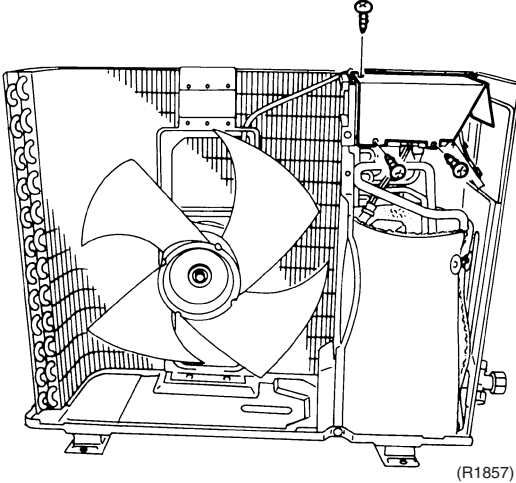
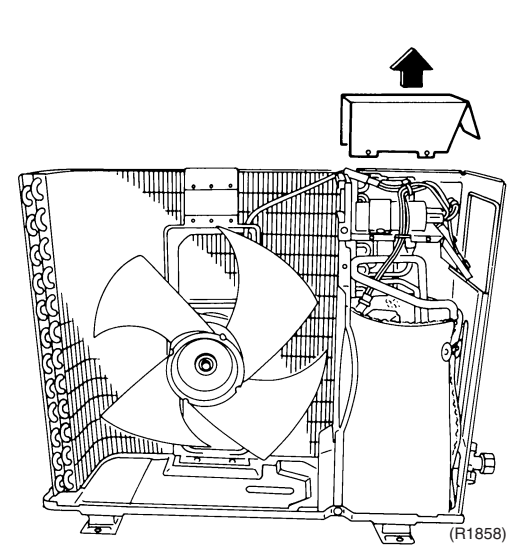
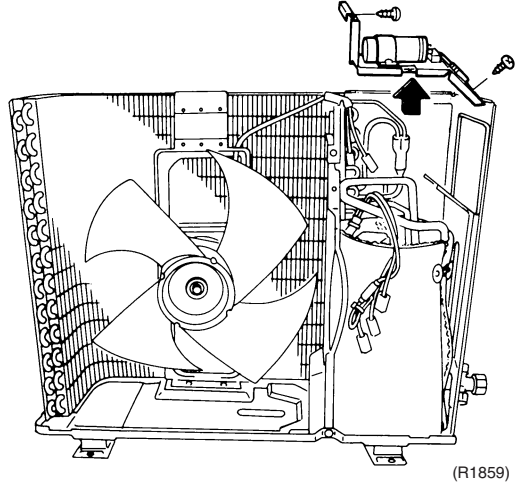

Warning Be sure to wait 10 minutes or more after turning off all power supplies before disassembling work.

Step	Procedure	Points
1. Remove the drip proof plate.	 <p>(R1857)</p>	
1 Remove the 3 screws of the drip proof plate.	 <p>(R1858)</p>	
2 Remove the drip proof plate.	 <p>(R1859)</p>	
2. Remove the electrical components ASSY.	1 Disconnect all the harnesses.	
1	2 Remove the 2 screws of electrical components ASSY.	
2	3 Remove the electrical components ASSY.	
3		

4. Removal of Outdoor Fan / Fan Motor

Procedure



Warning Be sure to wait 10 minutes or more after turning off all power supplies before disassembling work.

Step	Procedure	Points
1	Disconnect the 3 terminals of the fan motor lead wire. (2 from the fan motor capacitor, 1 from the magnetic contactor)	
2	Remove the nut and remove the outdoor fan.	<p> Nut size: M6 </p>
3	Open the 2 hooks and release the fan motor lead wire.	<p> When reassembling, align the ▼ mark of the outdoor fan with the D-cut section of the motor shaft. </p>
4	Remove the 2 screws of the fan motor.	<p> The fan motor should be restored so that the mark ▼ will be at upper side. </p>

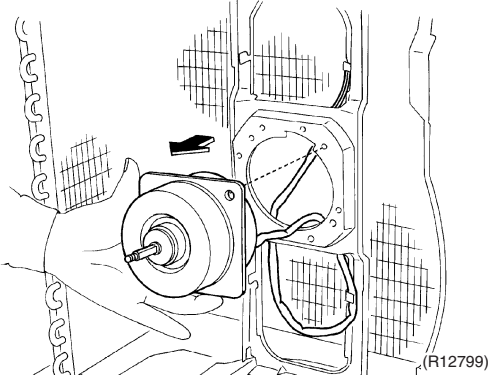
Step	Procedure	Points
5	Remove the fan motor.	
		

5. Removal of Sound Blanket

Procedure

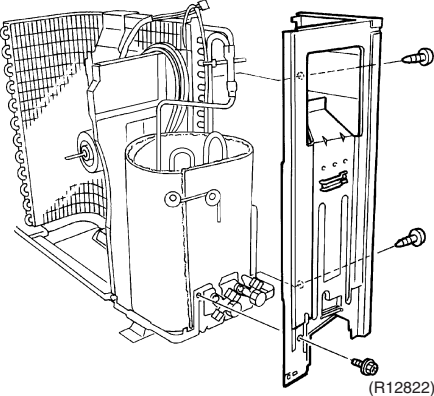
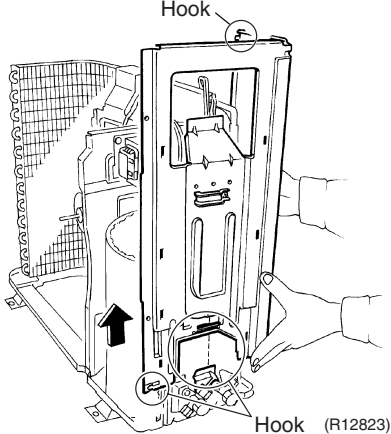
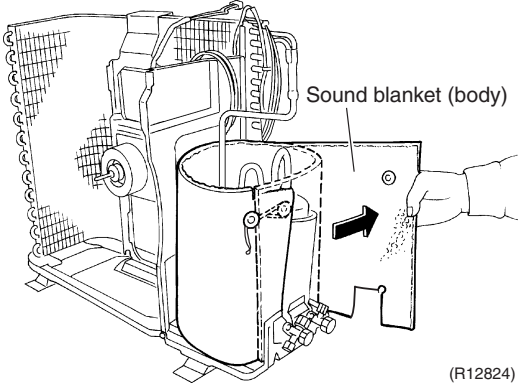
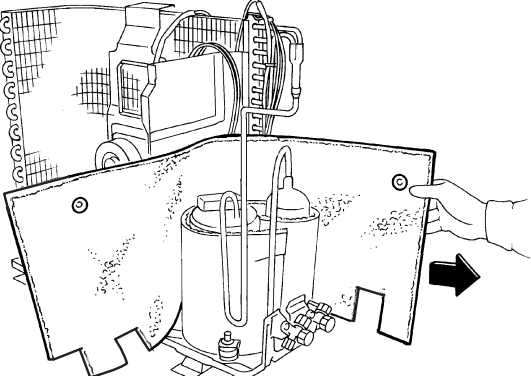

Warning Be sure to wait 10 minutes or more after turning off all power supplies before disassembling work.

Step	Procedure	Points
<p>1. Remove the right side panel.</p> <p>1 Remove the 3 screws of the right side panel.</p> <p>2 Lift up and remove the right side panel.</p>	 <p>(R12822)</p>  <p>Hook (R12823)</p>	<ul style="list-style-type: none"> ■ When reassembling, fit the 3 hooks.
<p>2. Remove the sound blanket.</p> <p>1 Untie the string and open the sound blanket (body).</p> <p>2 Pull out the sound blanket (body).</p>	 <p>Sound blanket (body)</p> <p>(R12824)</p>  <p>(R12837)</p>	<ul style="list-style-type: none"> ■ Since the piping ports are torn easily, remove the sound blanket carefully. ■ When restoring, the sound blanket should pass the internal side of the piping. ■ Some models also have a sound blanket (top).

6. Removal of Partition Plate

Procedure



Warning

Be sure to wait 10 minutes or more after turning off all power supplies before disassembling work.

Step	Procedure	Points
1	Disengage the compressor lead wires from the wire clip.	
	<p>(R12800)</p>	
2	Remove the 2 screws of the partition plate.	
	<p>(R1871)</p>	
3	Pull and remove the partition plate.	
	<p>(R12801)</p>	
4	When restoring the partition plate, put the hook into the bottom frame.	
	<p>(R1873)</p>	

7. Removal of Compressor

Procedure



Warning Be sure to wait 10 minutes or more after turning off all power supplies before disassembling work.

Step	Procedure	Points
<ul style="list-style-type: none"> ■ Before working, make sure that the refrigerant is empty in the circuit. ■ Be sure to apply nitrogen replacement when heating up the brazed part. 		<p>Warning Be careful not to get yourself burnt with the pipes and other parts that are heated by the gas brazing machine.</p> <p>Warning If the refrigerant gas leaks during work, ventilate the room. (If the refrigerant gas is exposed to flames, toxic gas may be generated.)</p> <p>Warning Since it may happen that the refrigerant oil in the compressor catches fire, prepare wet cloth so as to extinguish fire immediately.</p> <p>Caution From the viewpoint of global environment protection, do not discharge the refrigerant gas in the atmosphere. Make sure to collect all the refrigerant gas.</p>
<p>1 Remove the terminal cover and the partition plate.</p> <p>2 Disconnect the compressor lead wires.</p>		<p>Warning Be careful not to get yourself burnt with the pipes and other parts that are heated by the gas brazing machine.</p> <p>Warning If the refrigerant gas leaks during work, ventilate the room. (If the refrigerant gas is exposed to flames, toxic gas may be generated.)</p> <p>Warning Since it may happen that the refrigerant oil in the compressor catches fire, prepare wet cloth so as to extinguish fire immediately.</p> <p>Caution From the viewpoint of global environment protection, do not discharge the refrigerant gas in the atmosphere. Make sure to collect all the refrigerant gas.</p>
<p>3 Remove the 3 nuts of the compressor.</p>		<p>Cautions for restoration</p> <ol style="list-style-type: none"> 1. Restore the piping by non-oxidation brazing. 2. It is required to prevent the carbonization of the oil inside the four way valve and the deterioration of the gaskets affected by heat. (Keep below 120°C.) For the sake of this, wrap the four way valve with wet cloth and provide water so that the cloth does not dry. <p>In case of difficulty with gas brazing machine</p> <ol style="list-style-type: none"> 1. Disconnect the brazed part where is easy to disconnect and restore. 2. Cut pipes on the main unit with a tube cutter in order to make it easy to disconnect.

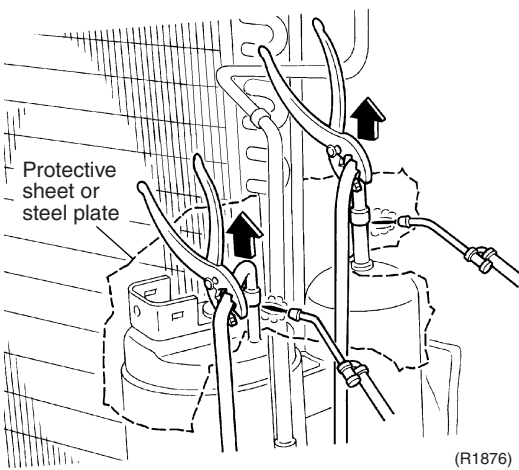
Step	Procedure	Points
4	Heat up the brazed part of the discharge side and disconnect.	Note: ■ Do not use a metal saw for cutting pipes by all means because the sawdust comes into the circuit.
5	Heat up the brazed part of the suction side and disconnect.	■ When withdrawing the pipes, be careful not to pinch them firmly with pliers. The pipes may get deformed.
6	Lift the compressor up and remove it.	■ Provide a protective sheet or a steel plate so that the brazing flame cannot influence peripheries.
	 <p data-bbox="518 369 630 436">Protective sheet or steel plate</p> <p data-bbox="957 660 1013 680">(R1876)</p>	■ Be careful so as not to burn the compressor terminals, the name plate, the heat exchanger fin.

Revision History

Month / Year	Version	Revised contents
01 / 2013	Si011052	First edition

Warning



- Daikin products are manufactured for export to numerous countries throughout the world. Prior to purchase, please confirm with your local authorised importer, distributor and/or retailer whether this product conforms to the applicable standards, and is suitable for use, in the region where the product will be used. This statement does not purport to exclude, restrict or modify the application of any local legislation.
- Ask a qualified installer or contractor to install this product. Do not try to install the product yourself. Improper installation can result in water or refrigerant leakage, electrical shock, fire or explosion.
- Use only those parts and accessories supplied or specified by Daikin. Ask a qualified installer or contractor to install those parts and accessories. Use of unauthorised parts and accessories or improper installation of parts and accessories can result in water or refrigerant leakage, electrical shock, fire or explosion.
- Read the User's Manual carefully before using this product. The User's Manual provides important safety instructions and warnings. Be sure to follow these instructions and warnings.

If you have any enquiries, please contact your local importer, distributor and/or retailer.

Cautions on product corrosion

1. Air conditioners should not be installed in areas where corrosive gases, such as acid gas or alkaline gas, are produced.
2. If the outdoor unit is to be installed close to the sea shore, direct exposure to the sea breeze should be avoided. If you need to install the outdoor unit close to the sea shore, contact your local distributor.

Dealer

DAIKIN INDUSTRIES, LTD.

Head Office:
Umeda Center Bldg., 2-4-12, Nakazaki-Nishi,
Kita-ku, Osaka, 530-8323 Japan

Tokyo Office:
JR Shinagawa East Bldg., 2-18-1, Konan,
Minato-ku, Tokyo, 108-0075 Japan

http://www.daikin.com/global_ac/

©All rights reserved