





Si01-983

# REMOVAL PROCEDURE



S E R V I C E M A N U A L

## 12000/18000 Btu/h Class

-  Outdoor Unit
-  Non-Inverter
-  Pair Type



# **Service Manual Removal Procedure**

## **Outdoor Unit**

### **●Cooling Only**

**RE12JV2S**

**RE18JV2S**

# Table of Contents

1. Removal of Outer Panels / Fan Motor.....	2
2. Removal of Electrical Components .....	10
3. Removal of Sound Blankets.....	14
4. Removal of Capillary Tube (Pattern 1).....	15
5. Removal of Capillary Tube (Pattern 2).....	16
6. Removal of Compressor ASSY .....	17



**Note:** ♦ The illustrations may be slightly different depending on the model.

# 1. Removal of Outer Panels / Fan Motor

**Procedure**



**Warning** Be sure to wait for 10 minutes or more after turning off all power supplies before disassembling work.

Step	Procedure	Points
<p>1. Appearance features</p>	<p>(R15226)</p> <p>(R16332)</p>	<ul style="list-style-type: none"> <li>■ Take care not to cut your finger by the fins of the outdoor heat exchanger.</li> </ul>
<p>2. Remove the panels.</p> <p>1 Remove the screw of the stop valve cover. Pull down the stop valve cover and remove it.</p>	<p>Stop valve cover</p> <p>Shield plate</p> <p>Hook</p> <p>(R7188)</p> <p>(R15256)</p>	<ul style="list-style-type: none"> <li>■ The stop valve cover is united with the shield plate.</li> <li>■ When reassembling, make sure to fit the 5 hooks.</li> </ul>

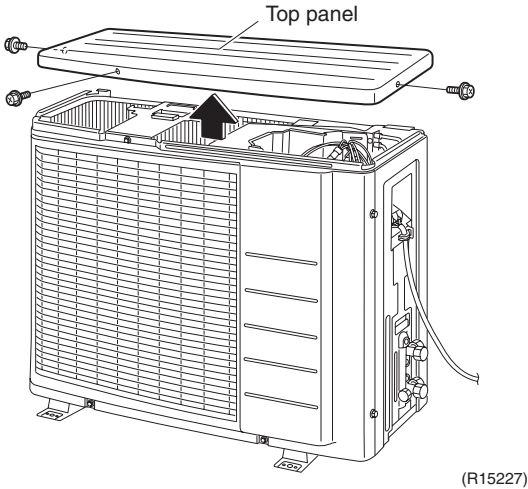
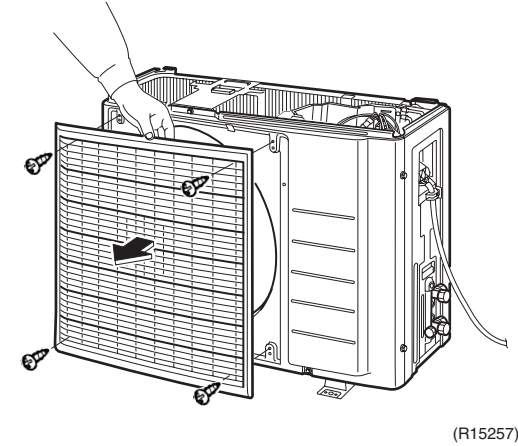
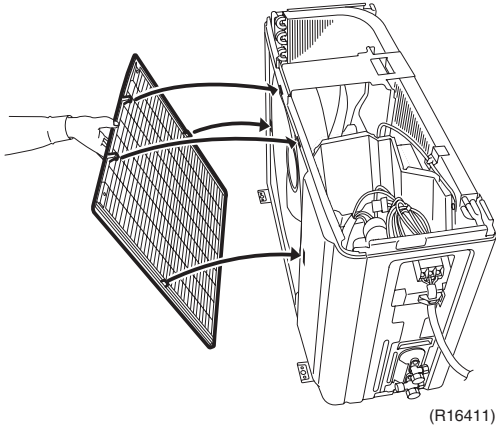
Step	Procedure	Points
2	Remove the 3 screws and remove the top panel.	
	 <p style="text-align: center;">Top panel</p> <p style="text-align: right;">(R15227)</p>	
3	Remove the 4 screws and remove the discharge grille.	
	 <p style="text-align: right;">(R15257)</p>	
	 <p style="text-align: right;">(R16411)</p>	<p>■ The discharge grille has 4 hooks.</p>

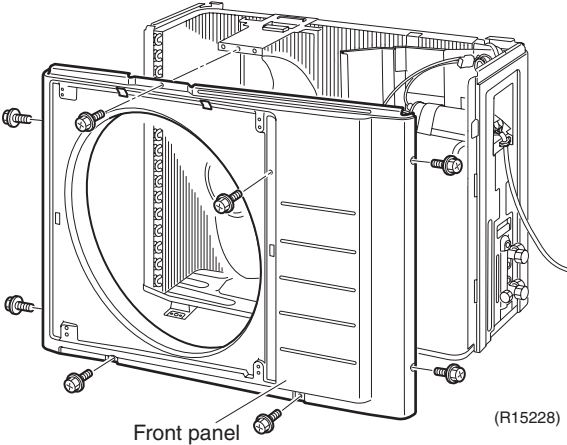
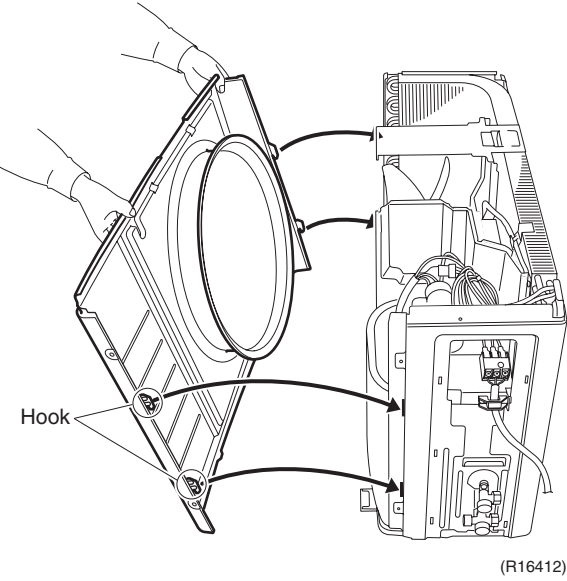
Step	Procedure	Points
4	Remove the 8 screws and remove the front panel.	
	 <p style="text-align: right;">(R15228)</p>	
5	Unfasten the hooks. Pull and remove the front panel.	<ul style="list-style-type: none"> <li>■ The front panel has 4 hooks.</li> </ul>
	 <p style="text-align: right;">(R16412)</p>	

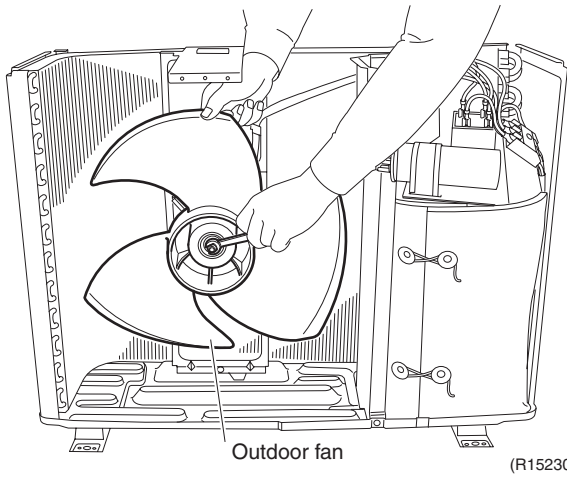
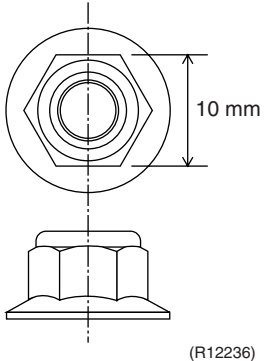
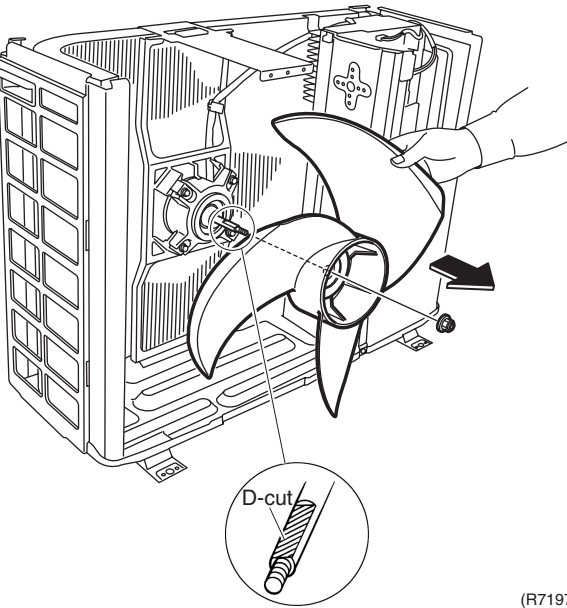
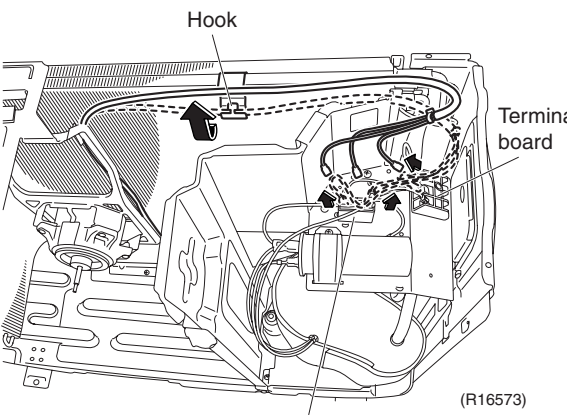
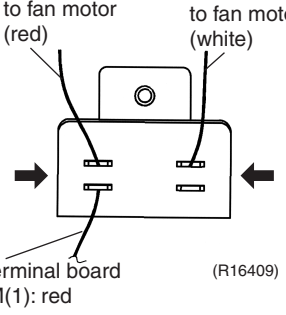
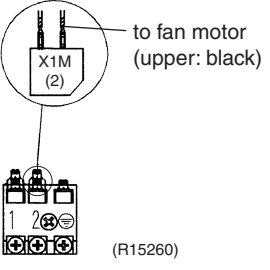
Step	Procedure	Points
3. Remove the fan motor.		
1 Remove the nut of the outdoor fan.		<ul style="list-style-type: none"> <li>■ Nut size: M6</li> </ul> 
2 Remove the outdoor fan.		<ul style="list-style-type: none"> <li>■ Align the ▼ mark of the outdoor fan with the D-cut section of the motor shaft when reassembling.</li> </ul>
3 Pull out the 2 terminals (red, white) from the fan capacitor (C2R).		<ul style="list-style-type: none"> <li>■ Fan capacitor (C2R)</li> </ul> 
4 Pull out the terminal (black) from the terminal board X1M (2).		
5 Release the fan motor lead wire from the hook.		
		<ul style="list-style-type: none"> <li>■ Terminal board (X1M)</li> </ul> 

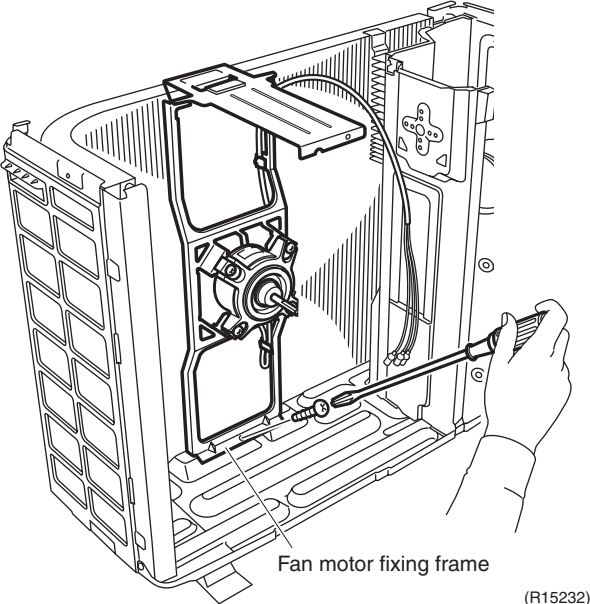
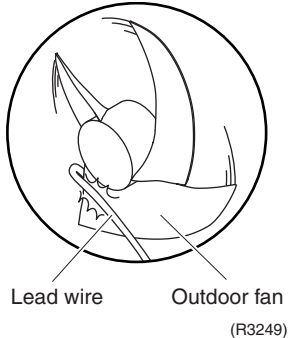
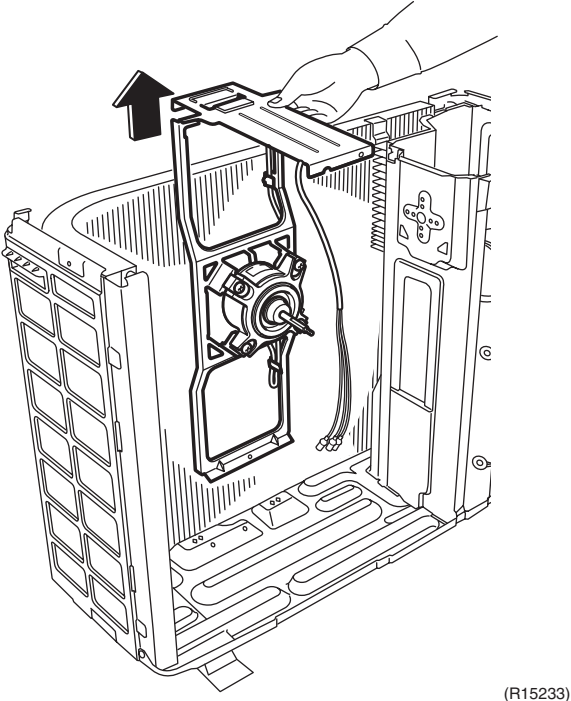
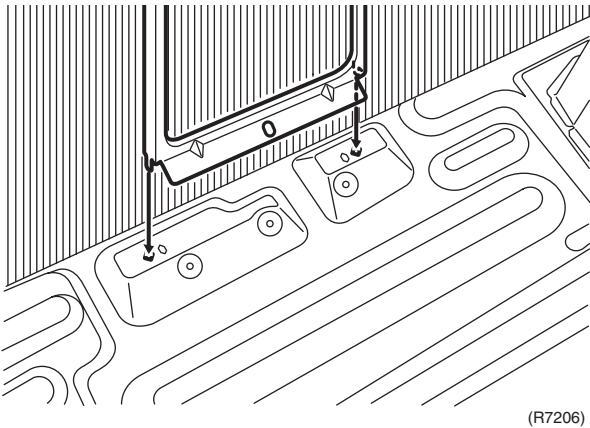
Step	Procedure	Points
6	Remove the screw and remove the fan motor fixing frame.	<ul style="list-style-type: none"> <li>Put the fan motor lead wire through the back of the fan motor when reassembling so as not to be entangled with the outdoor fan.</li> </ul>
	 <p>Fan motor fixing frame (R15232)</p>	 <p>Lead wire Outdoor fan (R3249)</p>
	 <p>(R15233)</p>	
	 <p>(R7206)</p>	<ul style="list-style-type: none"> <li>When reassembling, fit the lower hooks into the bottom frame.</li> </ul>

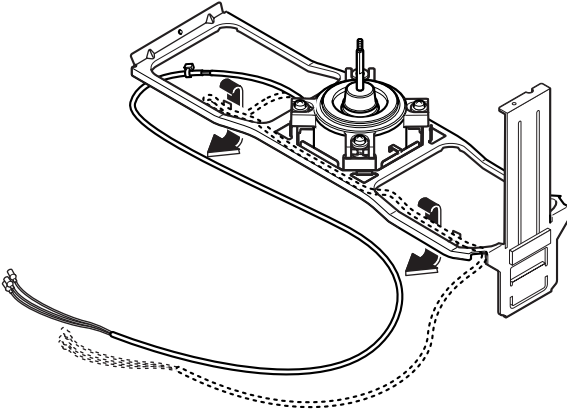
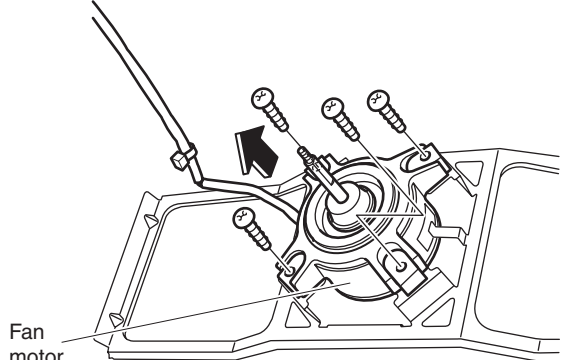

Step	Procedure	Points
7	Release the fan motor lead wire from the hooks.	
	 <p>(R15234)</p>	
8	Remove the 4 screws and remove the fan motor.	
	 <p>Fan motor</p> <p>(R15235)</p>	

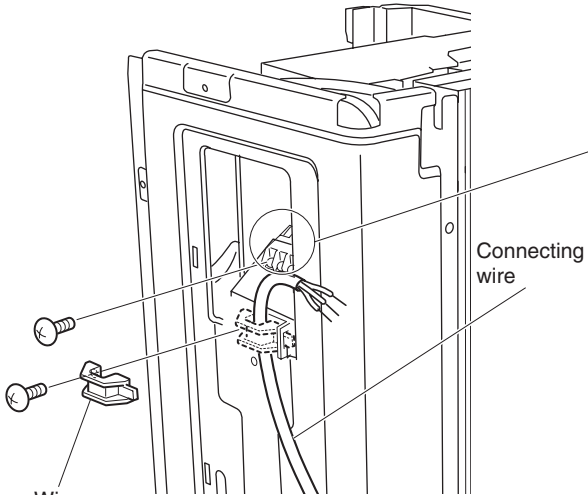
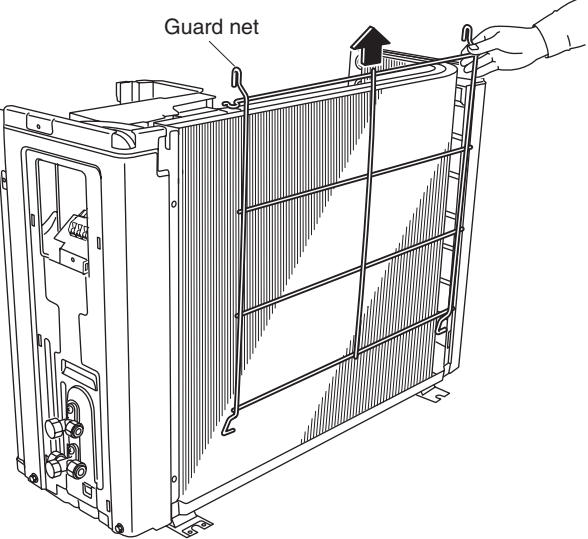
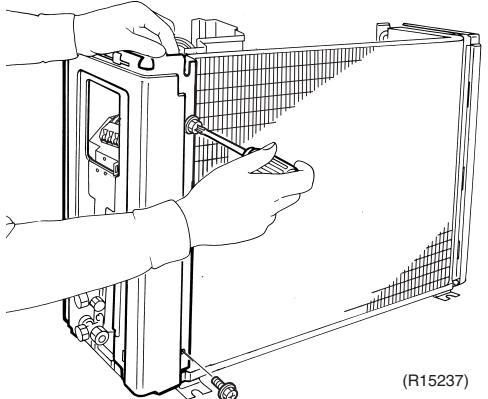
Step	Procedure	Points
4. Remove the right side panel.	 <p>Connecting wire</p> <p>Wire clamp</p> <p>(R15377)</p>	
3. Lift up and remove the guard net.	 <p>Guard net</p> <p>(R8284)</p>	
4. Remove the 2 screws on the rear side.	 <p>(R15237)</p>	

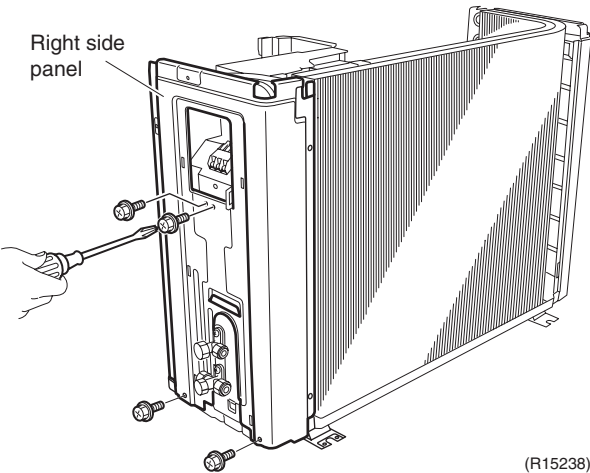
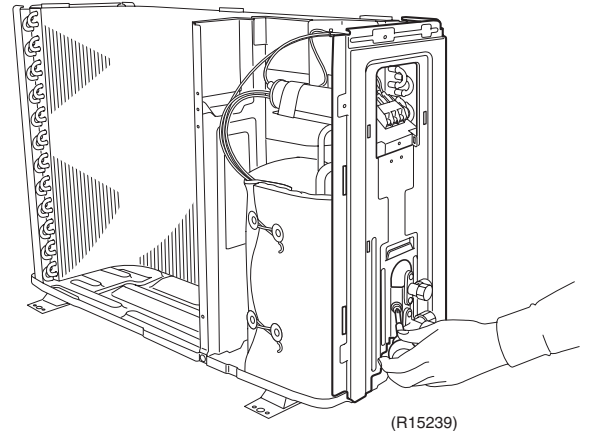
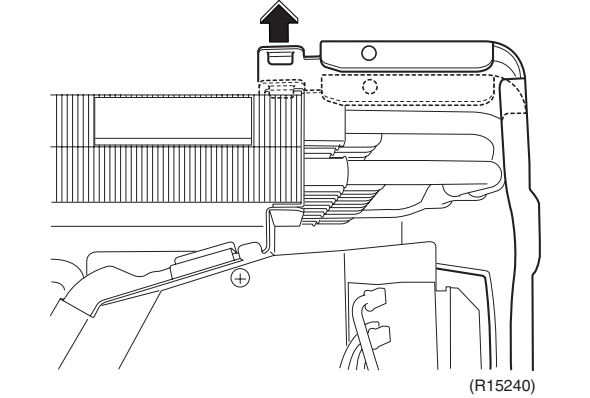
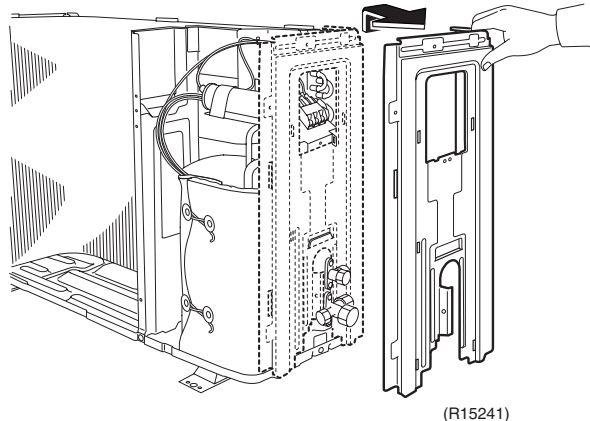
Step	Procedure	Points
5	Remove the 4 screws on the right side.	
	 <p>Right side panel</p> <p>(R15238)</p>	
6	Remove the screw near the connection port.	
	 <p>(R15239)</p>	
7	Unfasten the hook of the right side panel.	<p>■ When reassembling, make sure to fit the hook.</p>
	 <p>(R15240)</p>	
8	Remove the right side panel.	
	 <p>(R15241)</p>	

## 2. Removal of Electrical Components

**Procedure**

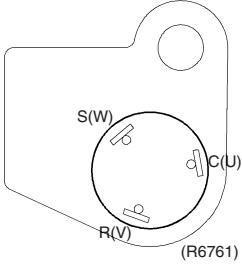

**Warning** Be sure to for wait for 10 minutes or more after turning off all power supplies before disassembling work.

Step	Procedure	Points
1	Remove the nut and remove the terminal cover.	<p><b>Preparation</b></p> <ul style="list-style-type: none"> <li>Remove the outer panels and disconnect the connector for the fan motor according to the "Removal of Outer Panels / Fan Motor".</li> </ul>
2	Disconnect the compressor lead wires.	
3	Lift and remove the electrical components ASSY.	<p>S(W) : Yellow C(U) : Blue R(V) : Red</p>

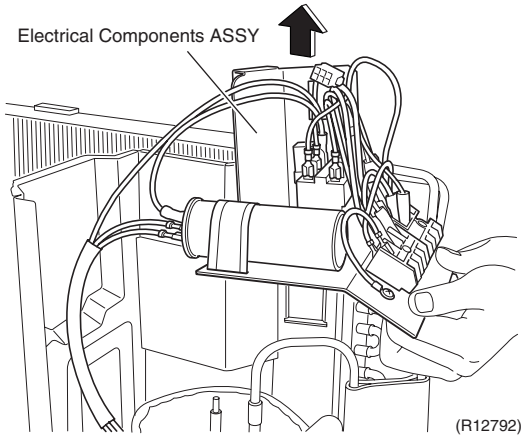
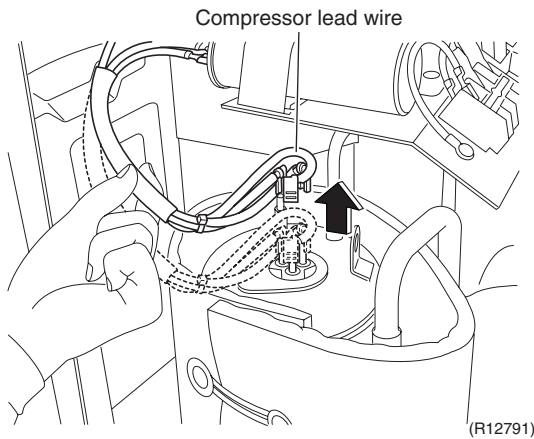
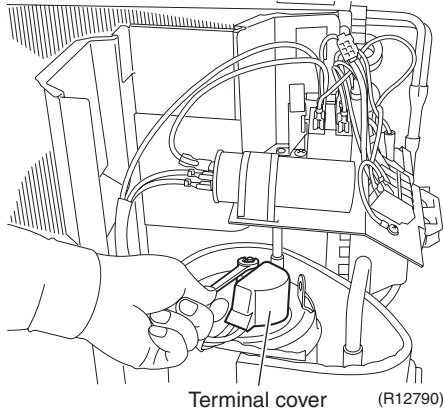

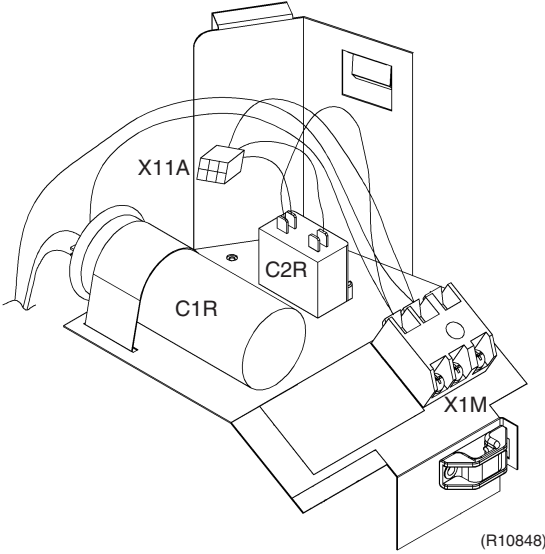
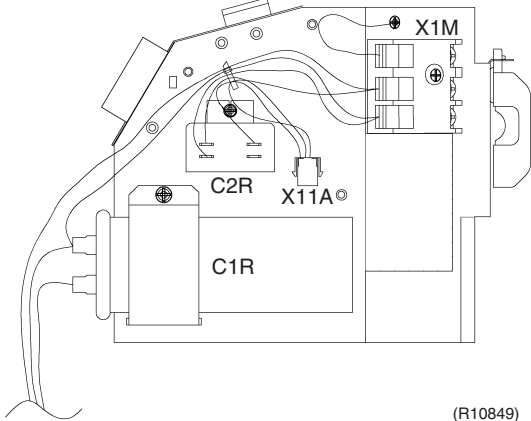
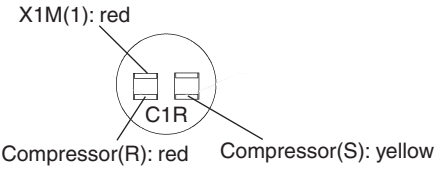
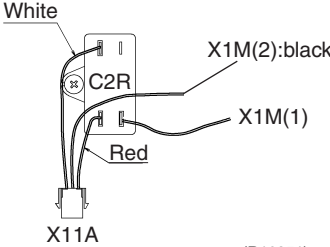
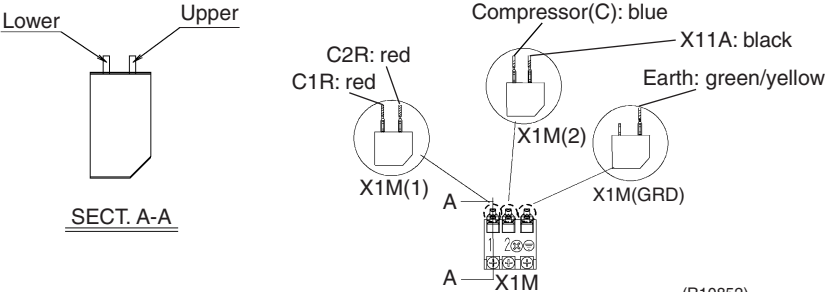
Step	Procedure	Points
<p>4</p> <p>The layout of the electrical components and connectors is different by models.</p>	<p><b>Pattern 1</b></p>  <p>(R10848)</p>  <p>(R10849)</p>  <p>(R10850)</p>  <p>(R10851)</p>  <p>(R10852)</p>	

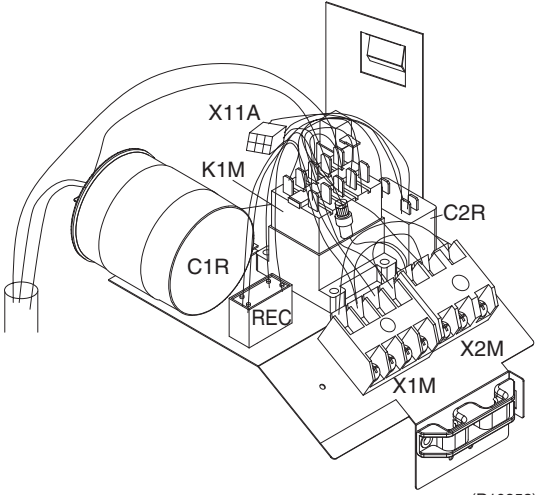
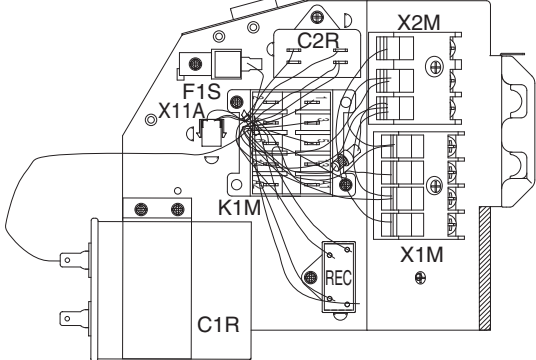
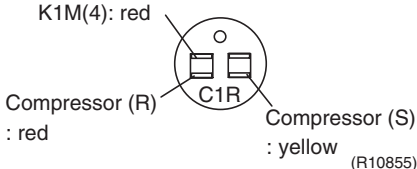
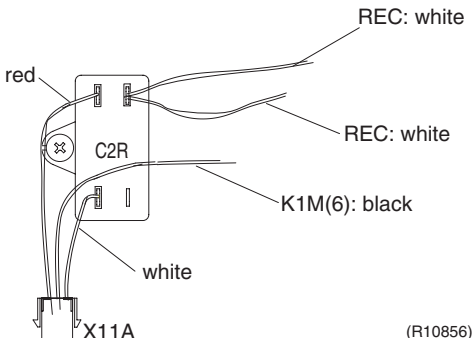
Step	Procedure	Points
	<p><b>Pattern 2</b></p>  <p>(R10853)</p>  <p>(R10854)</p>  <p>(R10855)</p>  <p>(R10856)</p>	

Step	Procedure	Points
	<p>(R10857)</p>	<p>(R10858)</p>

### 3. Removal of Sound Blankets

**Procedure**



**Warning** Be sure to wait for 10 minutes or more after turning off all power supplies before disassembling work.

Step	Procedure	Points
<p>1 Remove the sound blanket (top).</p> <p>2 Untie the 2 strings and open the sound blanket (body).</p>	<p>(R15242)</p>	<p><b>Preparation</b></p> <ul style="list-style-type: none"> <li>■ Remove the outer panels according to the "Removal of Outer Panels / Fan Motor".</li> <li>■ Remove the electrical components ASSY according to the "Removal of Electrical Components ASSY".</li> </ul>
<p>3 Remove the sound blanket (body).</p>	<p>(R15243)</p>	<ul style="list-style-type: none"> <li>■ Since the piping ports on the sound blanket are torn easily, remove the sound blanket carefully.</li> </ul>



## 4. Removal of Capillary Tube (Pattern 1)

### Procedure



**Warning** Be sure to wait for 10 minutes or more after turning off all power supplies before disassembling work.

Step	Procedure	Points
<ul style="list-style-type: none"> <li>■ Before working, make sure that the refrigerant gas is empty in the circuit.</li> <li>■ Be sure to apply nitrogen replacement when heating up the brazed part.</li> </ul>		<p><b>Warning</b> Be careful not to get yourself burnt with the pipes and other parts that are heated by the gas brazing machine.</p> <p><b>Warning</b> If the refrigerant gas leaks during work, ventilate the room. (If the refrigerant gas is exposed to flames, toxic gas may be generated.)</p> <p><b>Caution</b> From the viewpoint of global environment protection, do not discharge the refrigerant gas in the atmosphere. Make sure to collect all the refrigerant gas.</p>
<p>1 Remove the putty. Heat up the 2 brazed parts and remove the capillary tube.</p>		<p><b>Cautions for restoration</b></p> <ol style="list-style-type: none"> <li>1. Restore the piping by non-oxidation brazing.</li> <li>2. Avoid excessive heating. (Keep below 120°C)</li> </ol>
<p><b>Note:</b></p> <ul style="list-style-type: none"> <li>■ Do not use a metal saw for cutting pipes by all means because the sawdust comes into the circuit.</li> <li>■ When withdrawing the pipes, be careful not to pinch them firmly with pliers. The pipes may get deformed.</li> <li>■ Provide a protective sheet or a steel plate so that the brazing flame cannot influence peripheries.</li> <li>■ Be careful so as not to burn the compressor terminals, the name plate, the heat exchanger fin.</li> </ul>		<p><b>In case of difficulty with gas brazing machine</b></p> <ol style="list-style-type: none"> <li>1. Disconnect the brazed part where is easy to disconnect and restore.</li> <li>2. Cut pipes on the main unit with a tube cutter in order to make it easy to disconnect.</li> </ol>

# 5. Removal of Capillary Tube (Pattern 2)

**Procedure**



**Warning** Be sure to wait for 10 minutes or more after turning off all power supplies before disassembling work.

Step	Procedure	Points
<ul style="list-style-type: none"> <li>■ Before working, make sure that the refrigerant gas is empty in the circuit.</li> <li>■ Be sure to apply nitrogen replacement when heating up the brazed part.</li> </ul>	<p style="text-align: right;">(R15460)</p>	<p><b>Warning</b> Be careful not to get yourself burnt with the pipes and other parts that are heated by the gas brazing machine.</p> <p><b>Warning</b> If the refrigerant gas leaks during work, ventilate the room. (If the refrigerant gas is exposed to flames, toxic gas may be generated.)</p> <p><b>Caution</b> From the viewpoint of global environment protection, do not discharge the refrigerant gas in the atmosphere. Make sure to collect all the refrigerant gas.</p>
<p>1 Remove the putty. Heat up the 2 brazed parts and remove the capillary tube.</p>	<p style="text-align: right;">(R15461)</p>	<p><b>Cautions for restoration</b></p> <ol style="list-style-type: none"> <li>1. Restore the piping by non-oxidation brazing.</li> <li>2. Avoid excessive heating. (Keep below 120°C)</li> </ol>
<p><b>Note:</b></p> <ul style="list-style-type: none"> <li>■ Do not use a metal saw for cutting pipes by all means because the sawdust comes into the circuit.</li> <li>■ When withdrawing the pipes, be careful not to pinch them firmly with pliers. The pipes may get deformed.</li> <li>■ Provide a protective sheet or a steel plate so that the brazing flame cannot influence peripheries.</li> <li>■ Be careful so as not to burn the compressor terminals, the name plate, the heat exchanger fin.</li> </ul>	<p style="text-align: right;">(R15490)</p>	<p><b>In case of difficulty with gas brazing machine</b></p> <ol style="list-style-type: none"> <li>1. Disconnect the brazed part where is easy to disconnect and restore.</li> <li>2. Cut pipes on the main unit in order to make it easy to disconnect.</li> </ol>

# 6. Removal of Compressor ASSY

**Procedure**

**Warning** Be sure to wait for 10 minutes or more after turning off all power supplies before disassembling work.

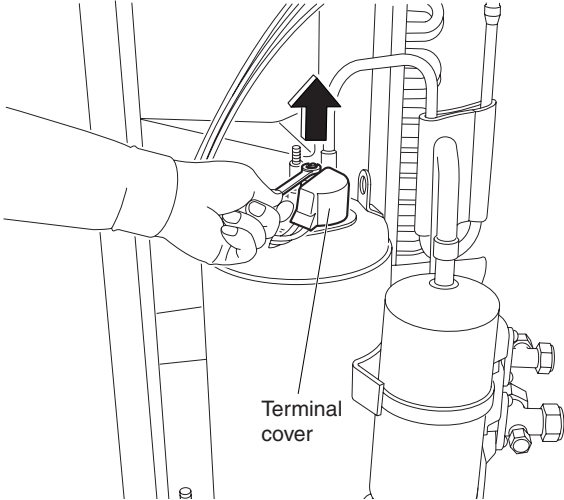
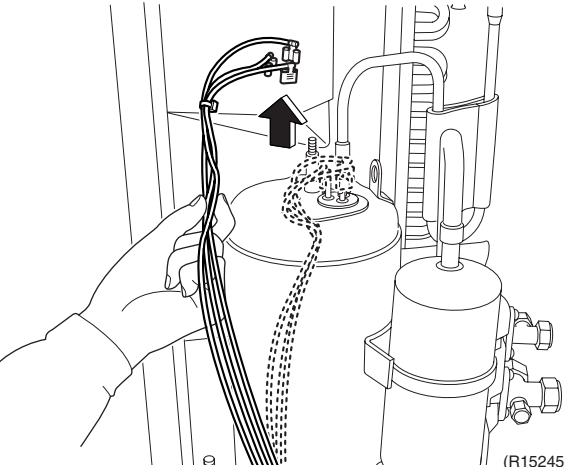
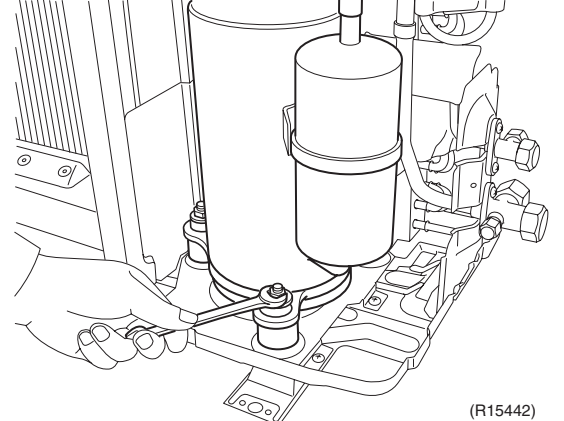
Step	Procedure	Points
1	Remove the nut and remove the terminal cover.	 <p>(R15244)</p>
2	Disconnect the compressor lead wires.	 <p>(R15245)</p> <p>S(W) : yellow C(U) : blue R(V) : red</p> <p>(R15393)</p>
3	Remove the 3 nuts of the compressor.	 <p>(R15442)</p>

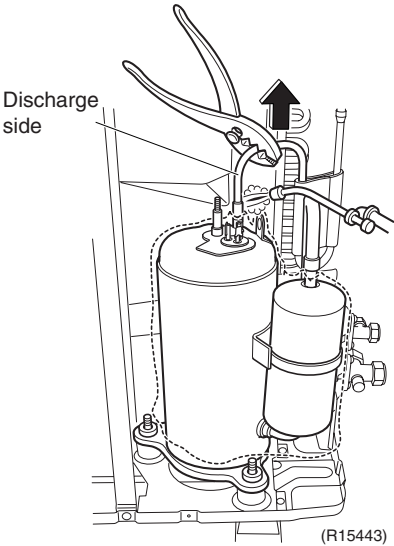
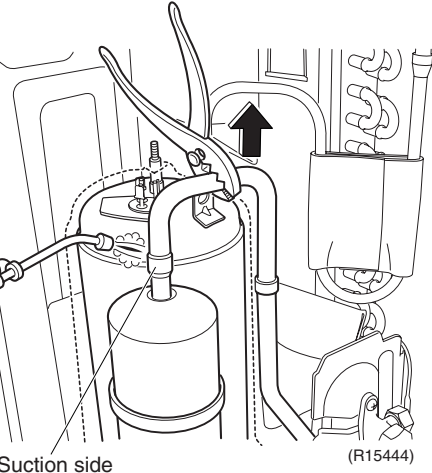
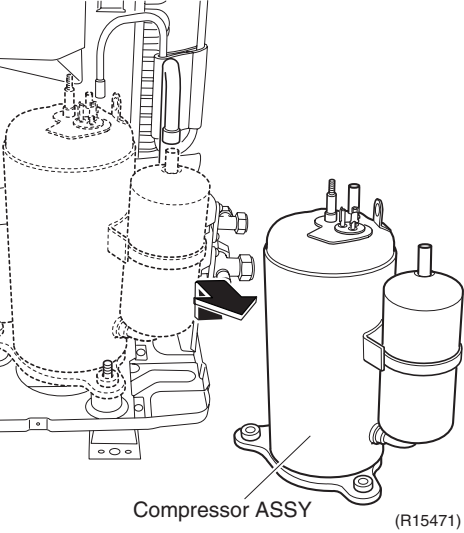
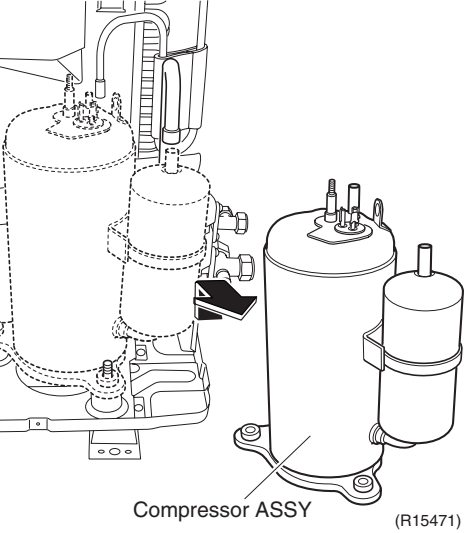
Step	Procedure	Points
<ul style="list-style-type: none"> <li>■ Before working, make sure that the refrigerant gas is empty in the circuit.</li> <li>■ Be sure to apply nitrogen replacement when heating up the brazed part.</li> </ul>	 <p style="text-align: center;">Discharge side (R15443)</p>	<p><b>Warning</b> Be careful not to get yourself burnt with the pipes and other parts that are heated by the gas brazing machine.</p>
<p>4 Heat up the brazed part of the discharge side and disconnect.</p>	 <p style="text-align: center;">Suction side (R15444)</p>	<p><b>Warning</b> If the refrigerant gas leaks during work, ventilate the room. (If the refrigerant gas is exposed to flames, toxic gas may be generated.)</p>
<p>5 Heat up the brazed part of the suction side and disconnect.</p>	 <p style="text-align: center;">Compressor ASSY (R15471)</p>	<p><b>Warning</b> Since it may happen that the refrigerant oil in the compressor catches fire, prepare wet cloth so as to extinguish fire immediately.</p> <p><b>Caution</b> From the viewpoint of global environment protection, do not discharge the refrigerant gas in the atmosphere. Make sure to collect all the refrigerant gas.</p> <p><b>Cautions for restoration</b></p> <ol style="list-style-type: none"> <li>1. Restore the piping by non-oxidation brazing.</li> <li>2. Avoid excessive heating. (Keep below 120°C)</li> </ol>
<p>6 Lift the compressor ASSY up and remove it.</p> <p><b>Note:</b></p> <ul style="list-style-type: none"> <li>■ Do not use a metal saw for cutting pipes by all means because the sawdust comes into the circuit.</li> <li>■ When withdrawing the pipes, be careful not to pinch them firmly with pliers. The pipes may get deformed.</li> <li>■ Provide a protective sheet or a steel plate so that the brazing flame cannot influence peripheries.</li> <li>■ Be careful so as not to burn the compressor terminals, the name plate, the heat exchanger fin.</li> </ul>	 <p style="text-align: center;">Compressor ASSY (R15471)</p>	<p><b>In case of difficulty with gas brazing machine</b></p> <ol style="list-style-type: none"> <li>1. Disconnect the brazed part where is easy to disconnect and restore.</li> <li>2. Cut pipes on the main unit with a tube cutter in order to make it easy to disconnect.</li> </ol>

# Revision History

Month / Year	Version	Revised contents
02 / 2013	Si01-983	First edition

Warning



- Daikin products are manufactured for export to numerous countries throughout the world. Prior to purchase, please confirm with your local authorised importer, distributor and/or retailer whether this product conforms to the applicable standards, and is suitable for use, in the region where the product will be used. This statement does not purport to exclude, restrict or modify the application of any local legislation.
- Ask a qualified installer or contractor to install this product. Do not try to install the product yourself. Improper installation can result in water or refrigerant leakage, electrical shock, fire or explosion.
- Use only those parts and accessories supplied or specified by Daikin. Ask a qualified installer or contractor to install those parts and accessories. Use of unauthorised parts and accessories or improper installation of parts and accessories can result in water or refrigerant leakage, electrical shock, fire or explosion.
- Read the User's Manual carefully before using this product. The User's Manual provides important safety instructions and warnings. Be sure to follow these instructions and warnings.

If you have any enquiries, please contact your local importer, distributor and/or retailer.

### Cautions on product corrosion

1. Air conditioners should not be installed in areas where corrosive gases, such as acid gas or alkaline gas, are produced.
2. If the outdoor unit is to be installed close to the sea shore, direct exposure to the sea breeze should be avoided. If you need to install the outdoor unit close to the sea shore, contact your local distributor.

### Dealer

### **DAIKIN INDUSTRIES, LTD.**

Head Office:  
Umeda Center Bldg., 2-4-12, Nakazaki-Nishi,  
Kita-ku, Osaka, 530-8323 Japan

Tokyo Office:  
JR Shinagawa East Bldg., 2-18-1, Konan,  
Minato-ku, Tokyo, 108-0075 Japan

[http://www.daikin.com/global\\_ac/](http://www.daikin.com/global_ac/)

©All rights reserved