



# REMOVAL PROCEDURE



## S E R V I C E M A N U A L

### 6.0 kW Class

-  Outdoor Unit
-  Non-Inverter
-  Pair Type



# **Service Manual Removal Procedure**

## **Outdoor Unit**

●Cooling Only  
R60GAV1A8

# Table of Contents

1. Removal of Outer Panels .....	2
2. Removal of Electrical Components ASSY .....	3
3. Removal of Compressor .....	6

# 1. Removal of Outer Panels

**Procedure**



**Warning**

Be sure to wait 10 minutes or more after turning off all power supplies before disassembling work.

Step	Procedure	Points
1	Remove the 4 screws (A) and remove the top panel.	
2	Remove the 6 screws (B) and remove the front panel.	
3	Remove the 2 screws and remove the service cover.	
4	Remove the 6 screws (C) and remove the side panel.	

## 2. Removal of Electrical Components ASSY

**Procedure**



**Warning** Be sure to wait 10 minutes or more after turning off all power supplies before disassembling work.

Step	Procedure	Points
1	Disconnect the relay connector for the fan motor.	
2	Detach the outdoor temperature thermistor and the outdoor heat exchanger thermistor.	

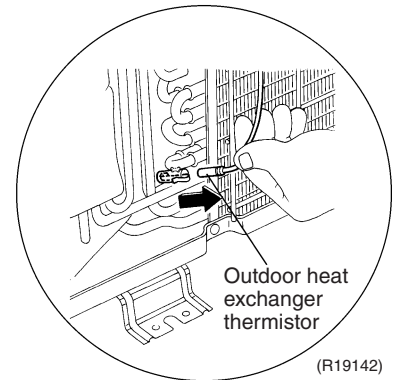
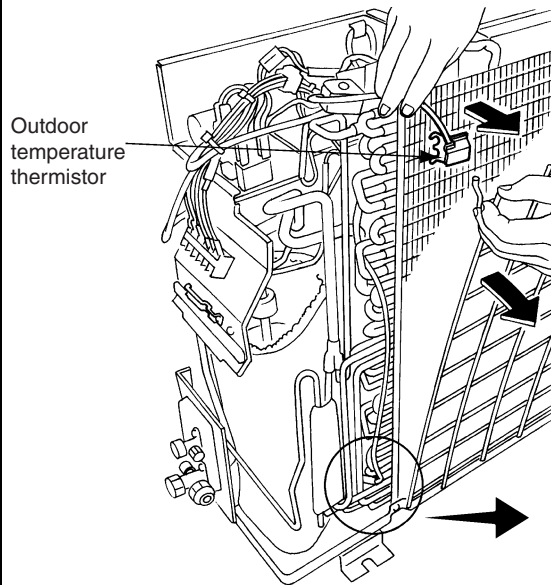
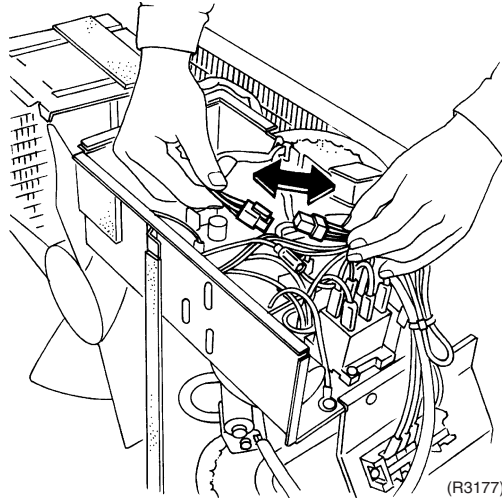

Step	Procedure	Points
3	Remove the sound blanket (top).	
4	Remove the terminal cover.	
5	Remove the overload protector and the 3 lead wires for the compressor together with mounting plate.	

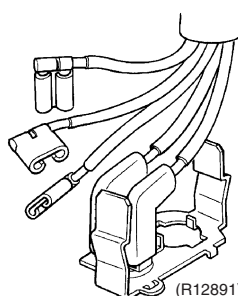
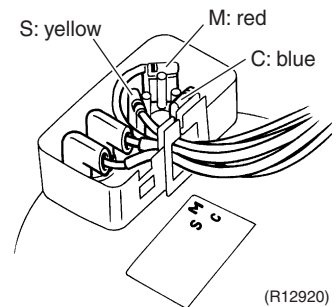
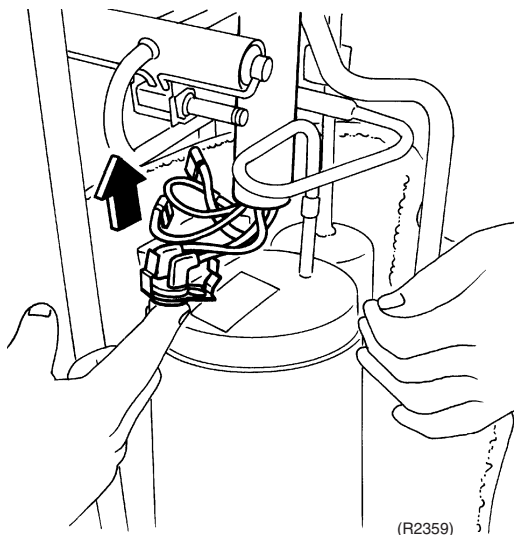
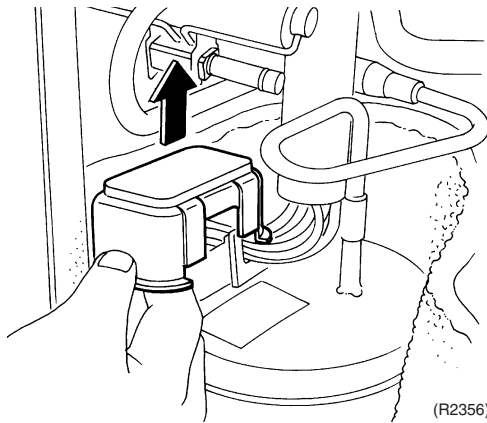
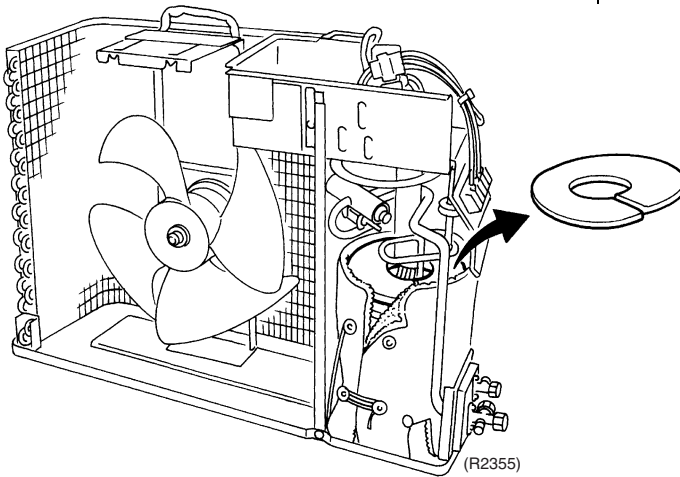

Step	Procedure	Points
6	Remove the screw.	
7	Lift up and remove the electrical components ASSY.	

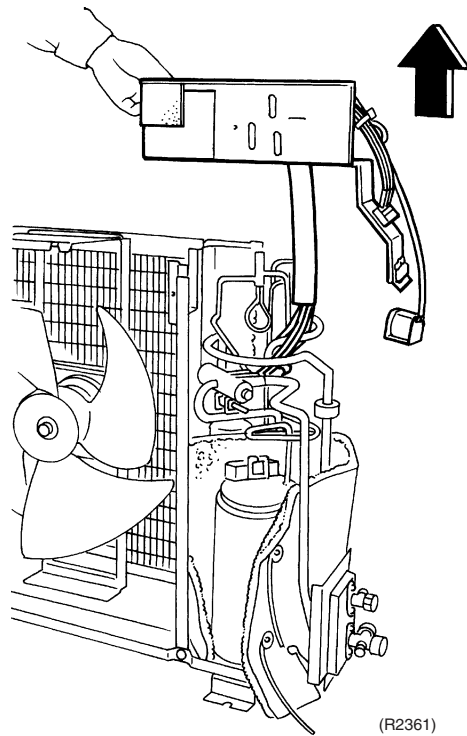
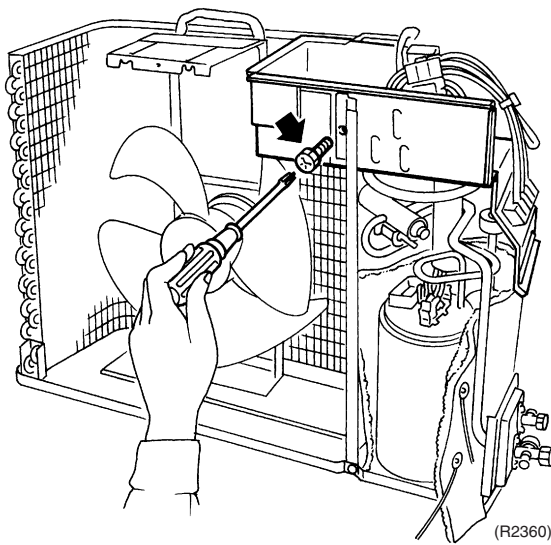

# 3. Removal of Compressor

**Procedure**



**Warning** Be sure to wait 10 minutes or more after turning off all power supplies before disassembling work.

Step	Procedure	Points
<ul style="list-style-type: none"> <li>■ Before working, make sure that the refrigerant is empty in the circuit.</li> <li>■ Be sure to apply nitrogen replacement when heating up the brazed part.</li> </ul>	<p style="text-align: right;">(R12805)</p>	<p><b>Warning</b> Be careful not to get yourself burnt with the pipes and other parts that are heated by the gas brazing machine.</p>
<p>1 Remove the sound blankets (top and body).</p>	<p style="text-align: right;">(R2363)</p>	<p><b>Warning</b> If the refrigerant gas leaks during work, ventilate the room. (If the refrigerant gas is exposed to flames, toxic gas may be generated.)</p>
<p>2 Disconnect the suction pipe and discharge pipe of the compressor at brazed sections.</p>	<p style="text-align: right;">(R2364)</p>	<p><b>Warning</b> Since it may happen that the refrigerant oil in the compressor catches fire, prepare wet cloth so as to extinguish fire immediately.</p>
		<p><b>Caution</b> From the viewpoint of global environment protection, do not discharge the refrigerant gas in the atmosphere. Make sure to collect all the refrigerant gas.</p>
		<p><b>Cautions for restoration</b></p> <ol style="list-style-type: none"> <li>1. Restore the piping by non-oxidation brazing.</li> <li>2. It is required to prevent the carbonization of the oil inside the four way valve and the deterioration of the gaskets affected by heat. (Keep below 120°C.) For the sake of this, wrap the four way valve with wet cloth and provide water so that the cloth does not dry.</li> </ol>
		<p><b>In case of difficulty with gas brazing machine</b></p> <ol style="list-style-type: none"> <li>1. Disconnect the brazed part where is easy to disconnect and restore.</li> <li>2. Cut pipes on the main unit with a tube cutter in order to make it easy to disconnect.</li> </ol>



Step	Procedure	Points
3	Remove the 3 nuts of the compressor.	<b>Note:</b> <ul style="list-style-type: none"><li>■ Do not use a metal saw for cutting pipes by all means because the sawdust comes into the circuit.</li><li>■ When withdrawing the pipes, be careful not to pinch them firmly with pliers. The pipes may get deformed.</li><li>■ Provide a protective sheet or a steel plate so that the brazing flame cannot influence peripheries.</li><li>■ Be careful so as not to burn the compressor terminals, the name plate, the heat exchanger fin.</li></ul>
4	Lift the compressor up and remove it.	

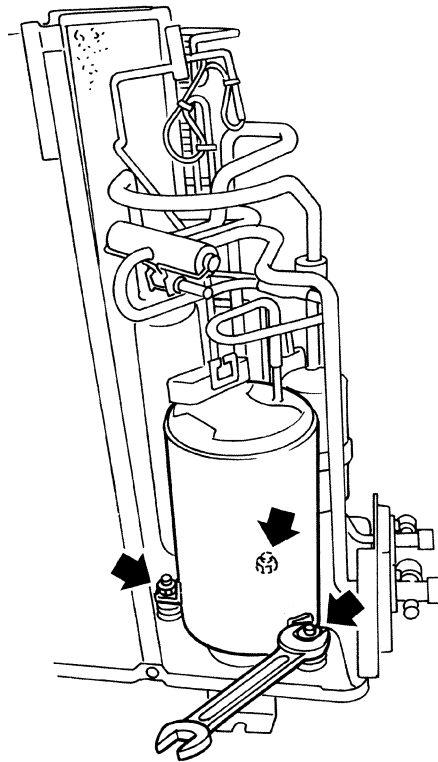

(R12806)

# Revision History

Month / Year	Version	Revised contents
06 / 2013	Si01-878	First edition

Warning



- Daikin products are manufactured for export to numerous countries throughout the world. Prior to purchase, please confirm with your local authorised importer, distributor and/or retailer whether this product conforms to the applicable standards, and is suitable for use, in the region where the product will be used. This statement does not purport to exclude, restrict or modify the application of any local legislation.
- Ask a qualified installer or contractor to install this product. Do not try to install the product yourself. Improper installation can result in water or refrigerant leakage, electrical shock, fire or explosion.
- Use only those parts and accessories supplied or specified by Daikin. Ask a qualified installer or contractor to install those parts and accessories. Use of unauthorised parts and accessories or improper installation of parts and accessories can result in water or refrigerant leakage, electrical shock, fire or explosion.
- Read the User's Manual carefully before using this product. The User's Manual provides important safety instructions and warnings. Be sure to follow these instructions and warnings.

If you have any enquiries, please contact your local importer, distributor and/or retailer.

### Cautions on product corrosion

1. Air conditioners should not be installed in areas where corrosive gases, such as acid gas or alkaline gas, are produced.
2. If the outdoor unit is to be installed close to the sea shore, direct exposure to the sea breeze should be avoided. If you need to install the outdoor unit close to the sea shore, contact your local distributor.

### Dealer

### **DAIKIN INDUSTRIES, LTD.**

Head Office:  
Umeda Center Bldg., 2-4-12, Nakazaki-Nishi,  
Kita-ku, Osaka, 530-8323 Japan

Tokyo Office:  
JR Shinagawa East Bldg., 2-18-1, Konan,  
Minato-ku, Tokyo, 108-0075 Japan

[http://www.daikin.com/global\\_ac/](http://www.daikin.com/global_ac/)

©All rights reserved