



REMOVAL PROCEDURE



S E R V I C E M A N U A L

6.0 kW Class

24000/28000 Btu/h Class

-  Outdoor Unit
-  Non-Inverter
-  Pair Type



Service Manual Removal Procedure

Outdoor Unit

●Cooling Only

R24GV2S

R28GV2S

RD60FV1K

Table of Contents

1. Removal of Outer Panels	2
2. Removal of Fan Motor / Outdoor Fan	5
3. Removal of Electrical Components ASSY	7
4. Removal of Sound Blankets	11
5. Removal of Compressor	12



Note: ♦ The illustrations may be slightly different depending on the model.

1. Removal of Outer Panels

Procedure



Warning

Be sure to wait 10 minutes or more after turning off all power supplies before disassembling work.

Step	Procedure	Points
1. Remove the top panel.	<p>(R5423)</p>	
1 Remove the 8 screws of the top panel.	<p>(R5424)</p>	
2 Pull the suction grille to unfasten the hook.	<p>(R5425)</p>	<ul style="list-style-type: none"> ■ Take care not to cut your finger by the fins of the outdoor heat exchanger.
3 Lift up and remove the top panel.	<p>(R5426)</p>	

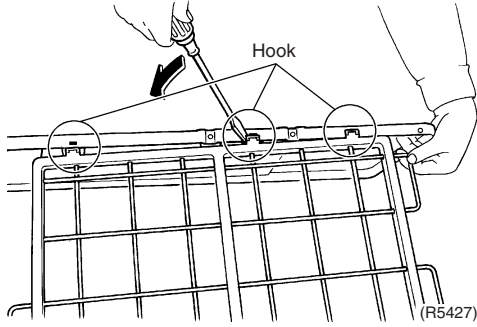
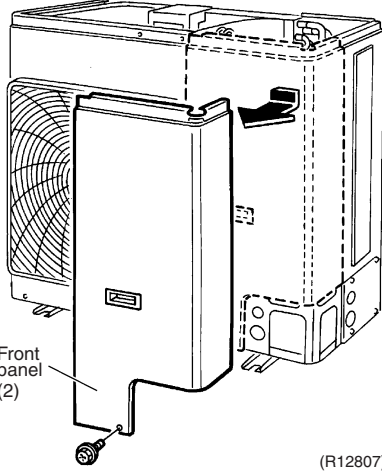
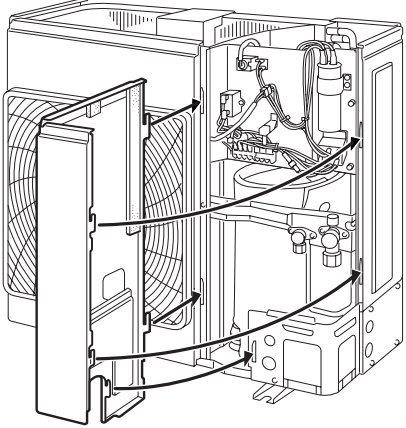
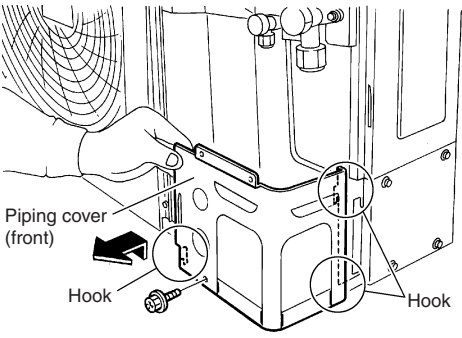
Step	Procedure	Points
4	Unfasten the hooks with a flat screwdriver and remove the suction grille.	
2. Remove the front panel (2).	 <p>(R5427)</p>  <p>Front panel (2)</p> <p>(R12807)</p>  <p>(R12808)</p>	<ul style="list-style-type: none"> ■ When reassembling, fit the 5 hooks.
3. Remove the piping cover (front).	 <p>Piping cover (front)</p> <p>Hook</p> <p>Hook</p> <p>(R13234)</p>	

Step	Procedure	Points
4. Remove the front panel (1).	<p>Front panel (1)</p> <p>(R12810)</p> <p>(R5432)</p> <p>(R8322)</p>	
1 Remove the 6 screws and remove the front panel (1).		

2. Removal of Fan Motor / Outdoor Fan

Procedure



Warning Be sure to wait 10 minutes or more after turning off all power supplies before disassembling work.

Step	Procedure	Points
1. Disconnect the each wire harness.	<p style="text-align: right;">(R6739)</p>	<p>Preparation</p> <ul style="list-style-type: none"> Remove the front panel according to the "Removal of the Outer Panels".
1 Loosen the 5 screws of the terminal board.	<p style="text-align: right;">(R6740)</p>	
2 Disconnect the 2 terminals for the fan motor capacitor.	<p style="text-align: right;">(R5436)</p>	<ul style="list-style-type: none"> Put the fan motor lead wire through the back of the fan motor when reassembling so as not to be entangled with the outdoor fan.
3 Unfasten the hook with a flat screwdriver.	<p style="text-align: right;">(R5437)</p>	<p style="text-align: right;">(R3249)</p>
4 Release the fan motor lead wire from the partition plate.		

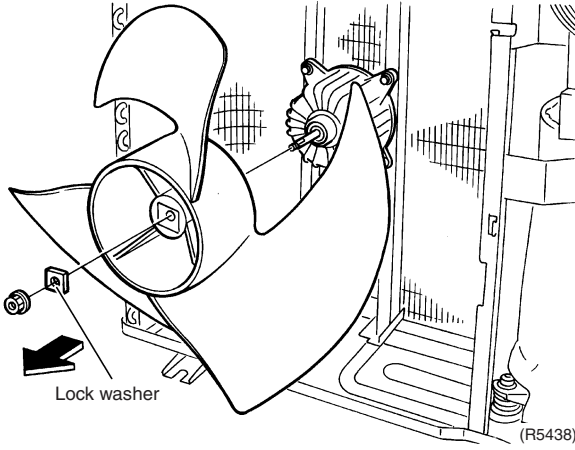
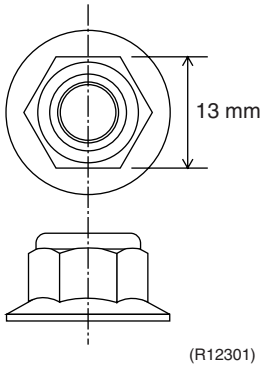
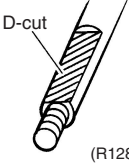
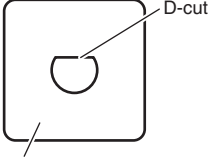
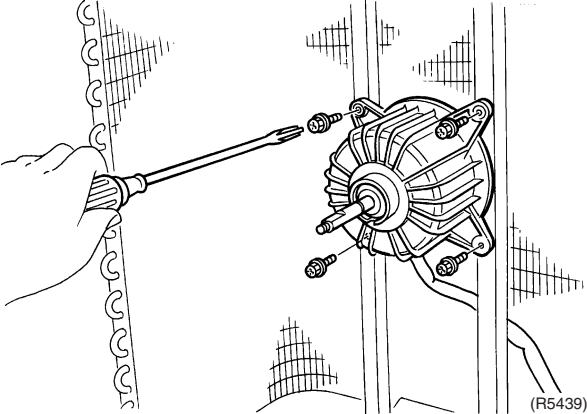
Step	Procedure	Points
<p>2. Remove the outdoor fan.</p> <p>1 Remove the nut and remove the outdoor fan.</p>	 <p>Lock washer</p> <p>(R5438)</p>	<ul style="list-style-type: none"> ■ Nut size : M8  <p>13 mm</p> <p>(R12301)</p> <ul style="list-style-type: none"> ■ When reassembling, fit the D-cuts of the lock washer and the shaft of fan motor.  <p>D-cut</p> <p>(R12834)</p>  <p>D-cut</p> <p>Lock washer</p> <p>(R12835)</p>
<p>3. Remove the fan motor.</p> <p>1 Remove the 4 screws and remove the fan motor.</p>	 <p>(R5439)</p>	<ul style="list-style-type: none"> ■ Be sure to remove the lower screws first. If the upper screws are removed first, the fan motor may tilt or fall because the center of its gravity is toward the front. It may cause injuries.

3. Removal of Electrical Components ASSY

Procedure



Warning Be sure to wait 10 minutes or more after turning off all power supplies before disassembling work.

Step	Procedure	Points
1. Remove the side panel.	<p>Side panel</p> <p>(R5440)</p> <p>Side panel</p> <p>(R8333)</p> <p>Hook</p> <p>(R5442)</p>	<p>Preparation</p> <ul style="list-style-type: none"> Remove the top panel, front panel (1) (2), and piping cover (front) according to the "Removal of Outer Panels".

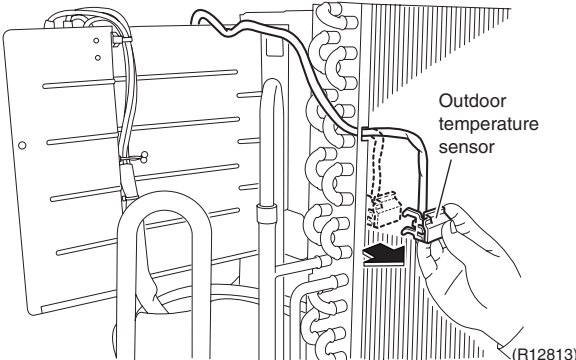
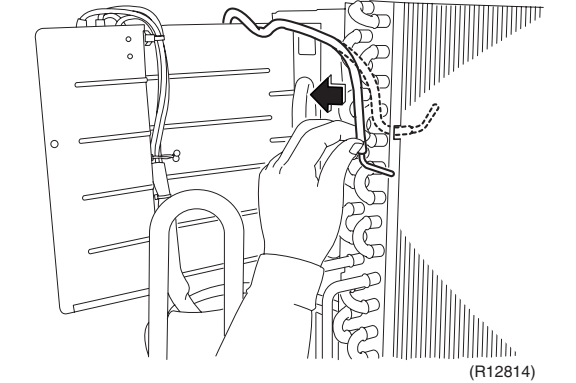
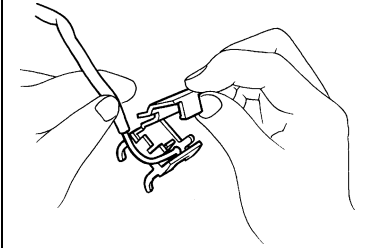
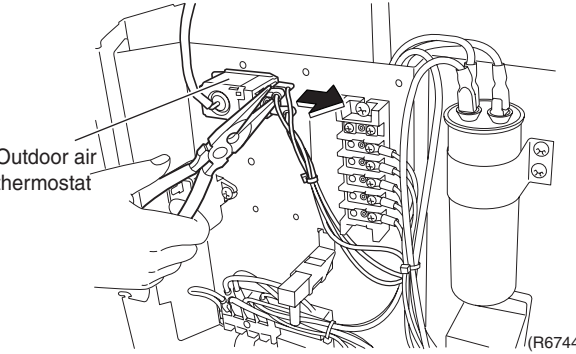
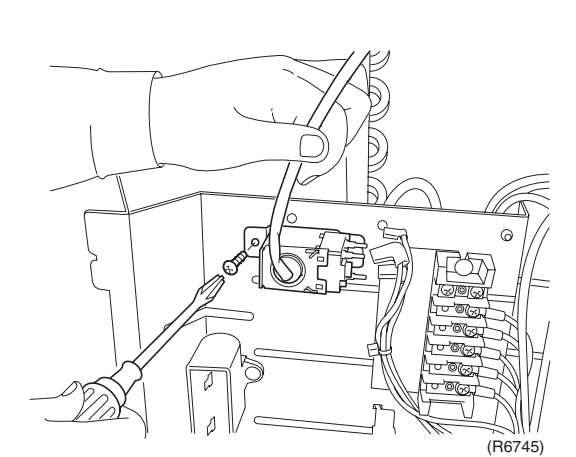
Step	Procedure	Points
2. Remove the outdoor temperature thermostat.	 	 <p>■ Remove the sensor fixing plate.</p>
1 Detach the outdoor temperature sensor.		
2 Disconnect the flag shape terminals of the outdoor air thermostat.		
3 Loosen the screw and remove the main unit of the outdoor air thermostat.		
4 Remove the outdoor air thermostat.		

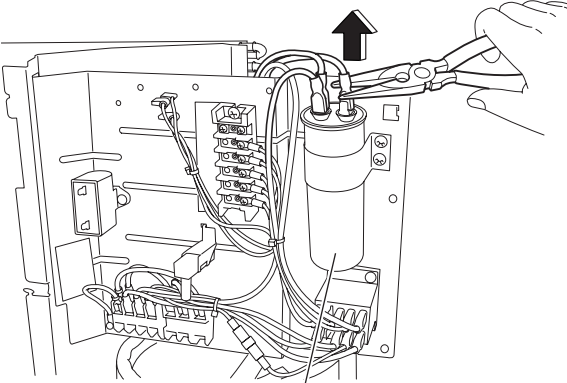
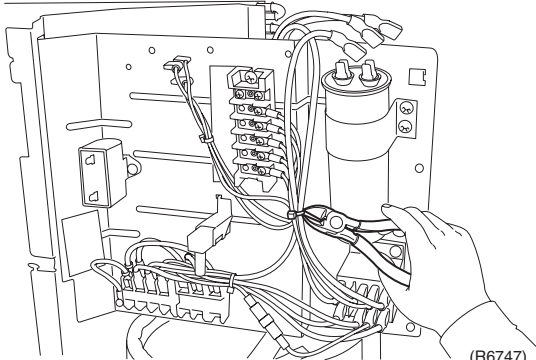
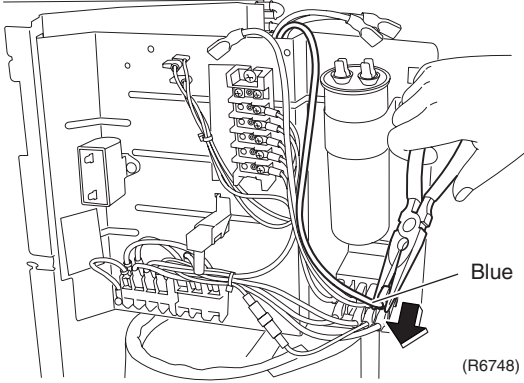
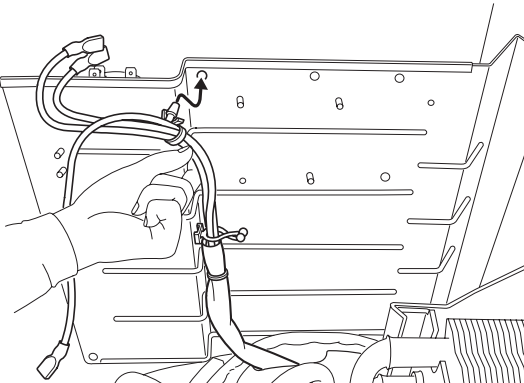
Step	Procedure	Points
3. Remove the capacitor.	<p data-bbox="153 248 451 344">1 Disconnect the terminals from the capacitor.</p>  <p data-bbox="746 651 842 674">Capacitor</p> <p data-bbox="1007 658 1066 680">(R6746)</p>	
4. Disconnect the each wire harness.	<p data-bbox="153 770 368 799">1 Cut the clamp.</p>  <p data-bbox="979 1167 1038 1189">(R6747)</p> <p data-bbox="153 1211 424 1267">2 Disconnect the blue terminal.</p>  <p data-bbox="979 1615 1038 1637">(R6748)</p> <p data-bbox="153 1659 440 1760">3 Detach the clamp for the compressor lead wire (rear side).</p>  <p data-bbox="979 2085 1038 2107">(R6749)</p>	

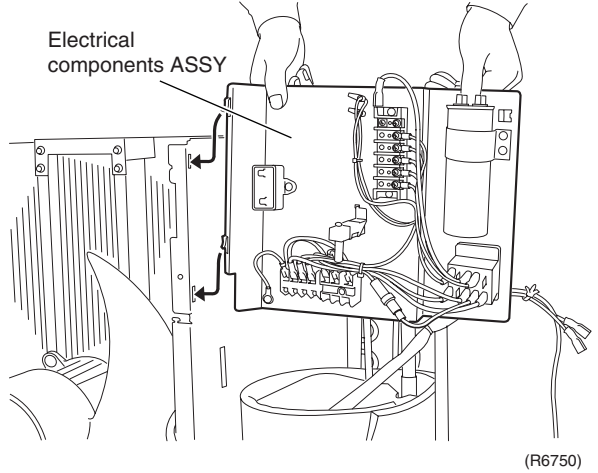
Step	Procedure	Points
<p>5. Remove the electrical components ASSY.</p>	<p>1 Lift the electrical components ASSY to unfasten the 2 hooks and remove it.</p>  <p>Electrical components ASSY</p> <p>(R6750)</p>	

4. Removal of Sound Blankets

Procedure



Warning

Be sure to wait 10 minutes or more after turning off all power supplies before disassembling work.

Step	Procedure	Points
1	Remove the sound blanket (top).	<p>Preparation</p> <ul style="list-style-type: none"> ■ Remove the electrical box according to the "Removal of Electrical Components ASSY". ■ Since the piping ports on the sound blanket are torn easily, remove the blanket carefully.
2	Remove the sound blanket (body).	

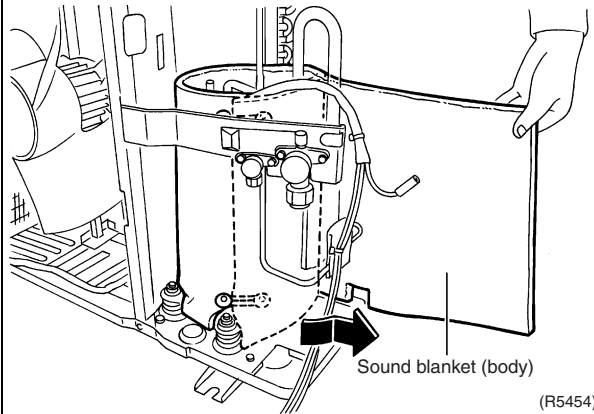
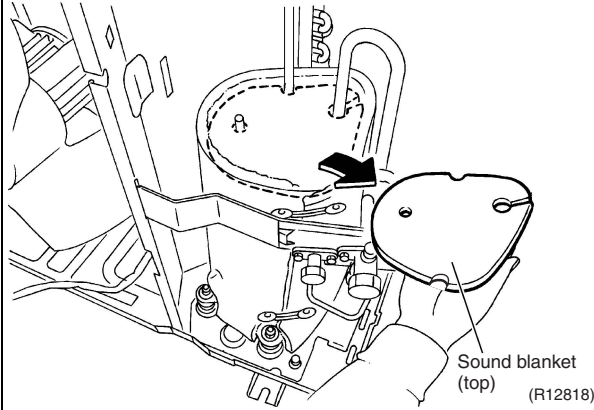

5. Removal of Compressor

Procedure



Warning Be sure to wait 10 minutes or more after turning off all power supplies before disassembling work.

Step	Procedure	Points
1	Remove the terminal cover.	<p>Terminal cover</p> <p>(R5455)</p> <p>Terminal cover fixture</p> <p>(R5456)</p>
2	Disconnect the compressor lead wires.	<p>Red (R)</p> <p>Blue (C)</p> <p>Yellow (S)</p> <p>(R5457)</p> <p>■ Be careful so as not to burn the compressor terminals or the name plate.</p> <p>(R12819)</p>
3	Remove the gasket.	<p>Gasket</p> <p>(R5458)</p> <p>S : Yellow C : Blue R : Red</p>

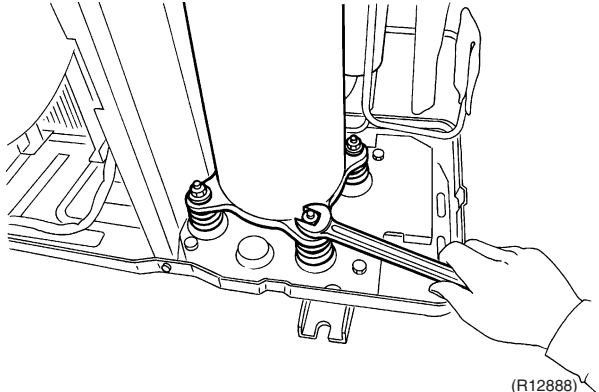
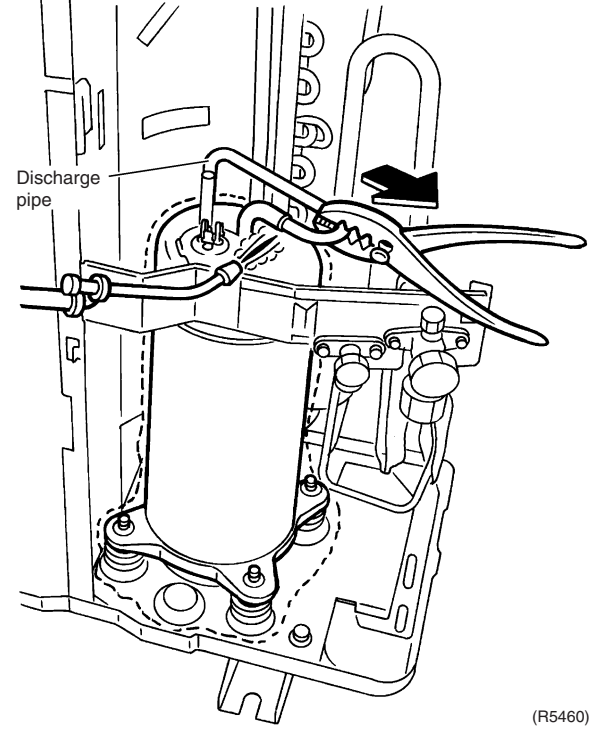
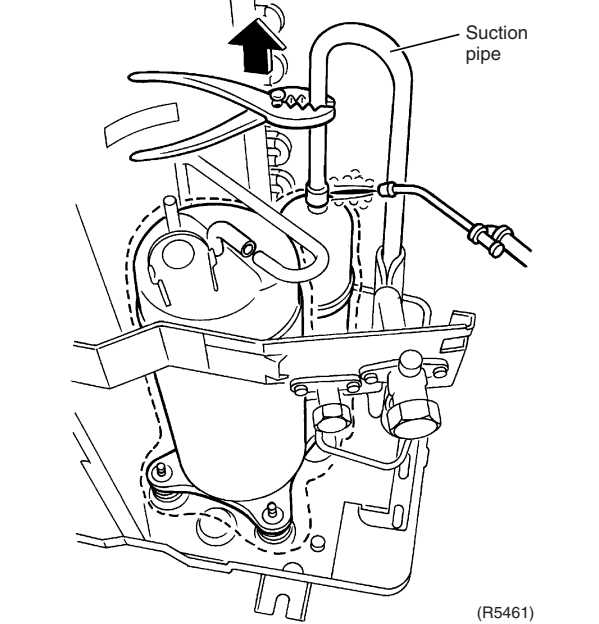
Step	Procedure	Points
4	Remove the 4 nuts of the compressor.	<p>Warning Be careful not to get yourself burnt with the pipes and other parts that are heated by the gas brazing machine.</p>
<ul style="list-style-type: none"> ■ Before working, make sure that the refrigerant is empty in the circuit. ■ Be sure to apply nitrogen replacement when heating up the brazed part. 	 <p style="text-align: right;">(R12888)</p>	<p>Warning If the refrigerant gas leaks during work, ventilate the room. (If the refrigerant gas is exposed to flames, toxic gas may be generated.)</p>
5	Heat up the brazed part of the discharge side and disconnect.	<p>Warning Since it may happen that the refrigerant oil in the compressor catches fire, prepare wet cloth so as to extinguish fire immediately.</p>
<p>Note:</p> <ul style="list-style-type: none"> ■ Do not use a metal saw for cutting pipes by all means because the sawdust comes into the circuit. ■ When withdrawing the pipes, be careful not to pinch them firmly with pliers. The pipes may get deformed. ■ Provide a protective sheet or a steel plate so that the brazing flame cannot influence peripheries. ■ Be careful so as not to burn the compressor terminals, the name plate, the heat exchanger fin. 	 <p style="text-align: right;">(R5460)</p>  <p style="text-align: right;">(R5461)</p>	<p>Caution From the viewpoint of global environment protection, do not discharge the refrigerant gas in the atmosphere. Make sure to collect all the refrigerant gas.</p> <p>Cautions for restoration</p> <ol style="list-style-type: none"> 1. Restore the piping by non-oxidation brazing. 2. It is required to prevent the carbonization of the oil inside the four way valve and the deterioration of the gaskets affected by heat. (Keep below 120°C.) For the sake of this, wrap the four way valve with wet cloth and provide water so that the cloth does not dry. <p>In case of difficulty with gas brazing machine</p> <ol style="list-style-type: none"> 1. Disconnect the brazed part where is easy to disconnect and restore. 2. Cut pipes on the main unit with a tube cutter in order to make it easy to disconnect.

Revision History

Month / Year	Version	Revised contents
07 / 2013	Si01-782	First edition

Warning



- Daikin products are manufactured for export to numerous countries throughout the world. Prior to purchase, please confirm with your local authorised importer, distributor and/or retailer whether this product conforms to the applicable standards, and is suitable for use, in the region where the product will be used. This statement does not purport to exclude, restrict or modify the application of any local legislation.
- Ask a qualified installer or contractor to install this product. Do not try to install the product yourself. Improper installation can result in water or refrigerant leakage, electrical shock, fire or explosion.
- Use only those parts and accessories supplied or specified by Daikin. Ask a qualified installer or contractor to install those parts and accessories. Use of unauthorised parts and accessories or improper installation of parts and accessories can result in water or refrigerant leakage, electrical shock, fire or explosion.
- Read the User's Manual carefully before using this product. The User's Manual provides important safety instructions and warnings. Be sure to follow these instructions and warnings.

If you have any enquiries, please contact your local importer, distributor and/or retailer.

Cautions on product corrosion

1. Air conditioners should not be installed in areas where corrosive gases, such as acid gas or alkaline gas, are produced.
2. If the outdoor unit is to be installed close to the sea shore, direct exposure to the sea breeze should be avoided. If you need to install the outdoor unit close to the sea shore, contact your local distributor.

Dealer

DAIKIN INDUSTRIES, LTD.

Head Office:
Umeda Center Bldg., 2-4-12, Nakazaki-Nishi,
Kita-ku, Osaka, 530-8323 Japan

Tokyo Office:
JR Shinagawa East Bldg., 2-18-1, Konan,
Minato-ku, Tokyo, 108-0075 Japan

http://www.daikin.com/global_ac/

©All rights reserved