

REMOVAL PROCEDURE



SERVICE
MANUAL

S E R V I C E M A N U A L

12000 Btu/h Class

-  Outdoor Unit
-  Inverter
-  Pair Type

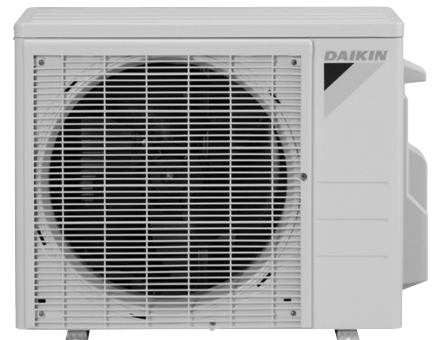

Service Manual Removal Procedure

Outdoor Unit

●Heat Pump
RXL12QMVJU

Table of Contents

1. Outer Panels	2
2. Outdoor Fan / Fan Motor.....	4
3. Drain Pan Heater (Option)	6
4. Electrical Box / PCB.....	8
5. Thermistor ASSY	12
6. Sound Blankets / Partition Plate.....	16
7. Electronic Expansion Valve Coil / Four Way Valve.....	18
8. Compressor.....	21

1. Outer Panels



Warning

◆ Be sure to wait for 10 minutes or more after turning off all power supplies before disassembling work.

Step	Procedure	Points
1	Remove the 3 screws and remove the top panel.	
2	Remove the 4 screws of the front panel.	
3	Unfasten the 3 left side hooks, and then the 2 right side hooks.	
4	Remove the front panel.	
5	Remove the 4 screws.	

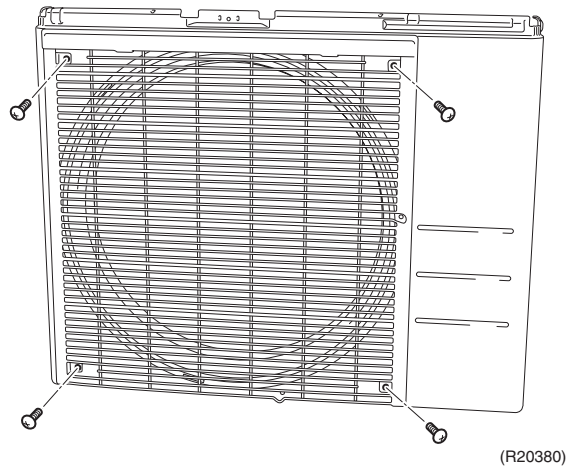
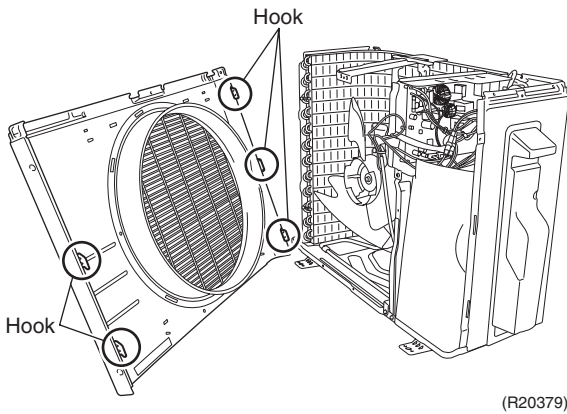
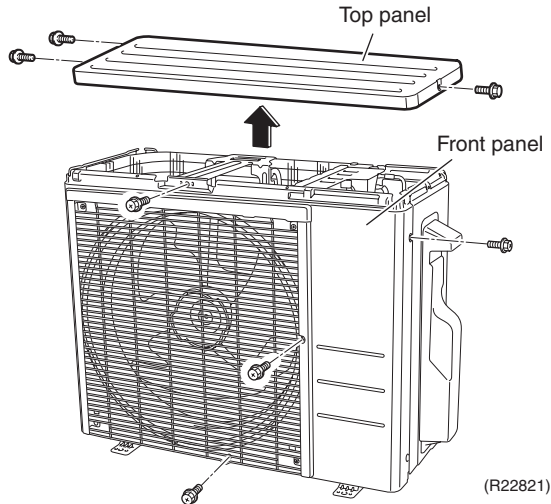

■ When reassembling, make sure that the 5 hooks are securely fastened.

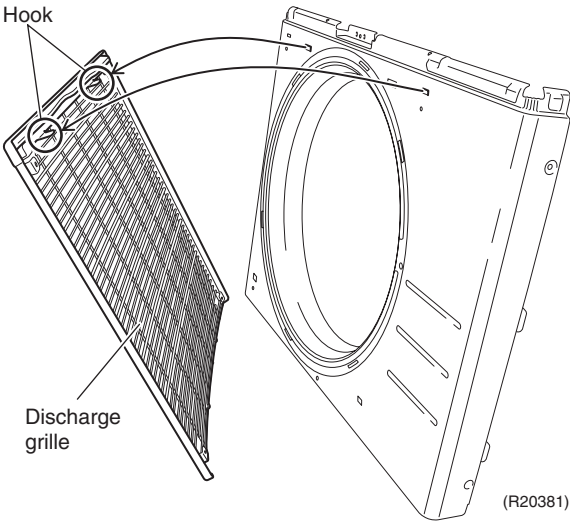
Step	Procedure	Points
6	Unfasten the 2 hooks on the top and remove the discharge grille.	
		

2. Outdoor Fan / Fan Motor



Warning

- ◆ Be sure to wait for 10 minutes or more after turning off all power supplies before disassembling work.

Step	Procedure	Points
1	Disconnect the connector [S70] and remove the filament tape.	[S70]: fan motor
2	Release the fan motor lead wire from the groove.	<ul style="list-style-type: none"> ■ When reassembling, put the fan motor lead wire through the back of the fan motor so as not to be entangled with the outdoor fan.
3	Remove the nut of the outdoor fan.	■ Nut size: M6
4	Remove the outdoor fan.	<ul style="list-style-type: none"> ■ Align the ▼ mark of the outdoor fan with the D-cut section of the motor shaft when reassembling.

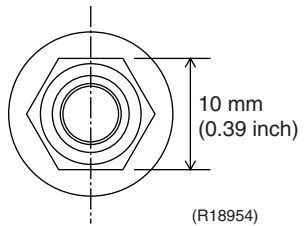
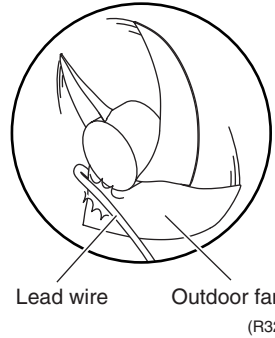
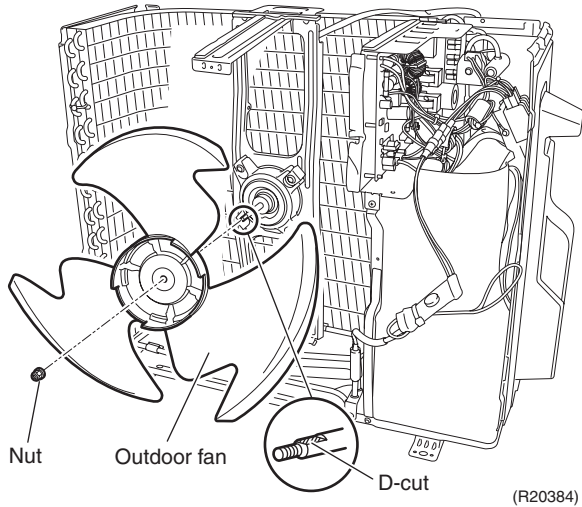
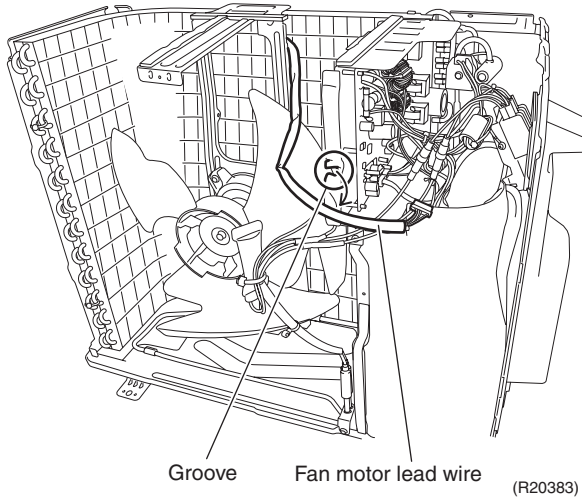
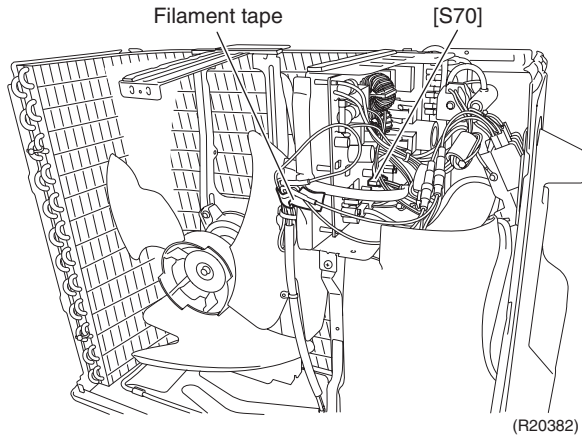

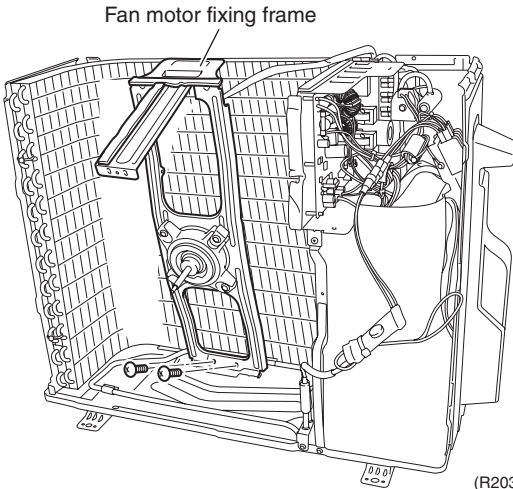
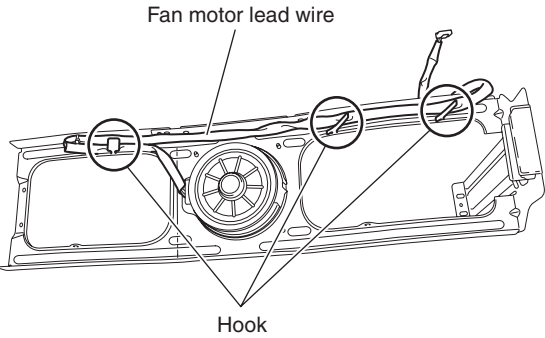
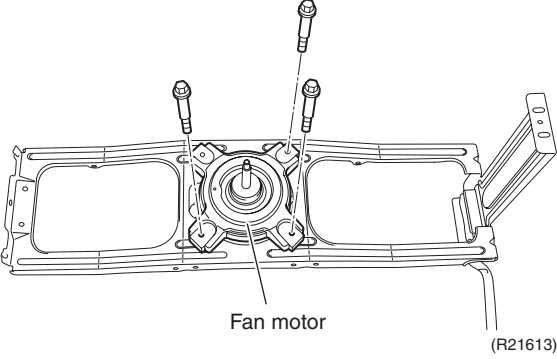
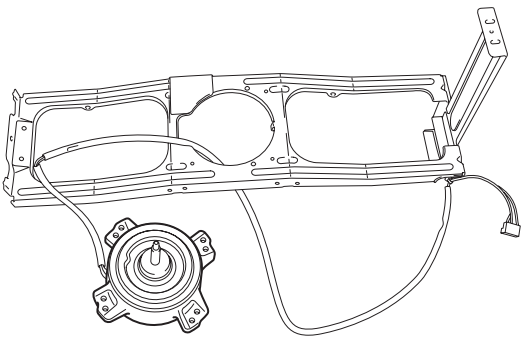
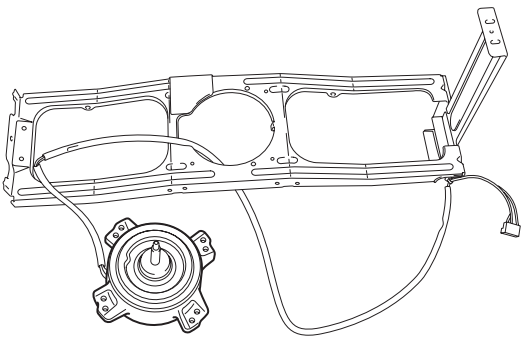
Step	Procedure	Points
5	Remove the 2 screws and remove the fan motor fixing frame.	<ul style="list-style-type: none"> ■ When reassembling, fit the 2 lower hooks into the bottom frame.
6	Open the 3 hooks and release the fan motor lead wire.	 
7	Remove the 3 screws from the fan motor.	
8	Remove the fan motor.	 

3. Drain Pan Heater (Option)



Warning

◆ Be sure to wait for 10 minutes or more after turning off all power supplies before disassembling work.

Step	Procedure	Points
1	Disconnect the 2 connectors from the terminal board.	1: black, back 2: white, back
2	Remove the screw from the partition plate.	(R20387)
3	Remove the 3 screws.	(R20388)

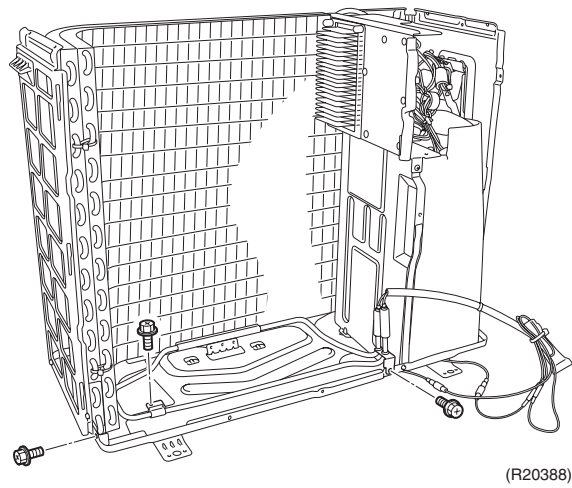
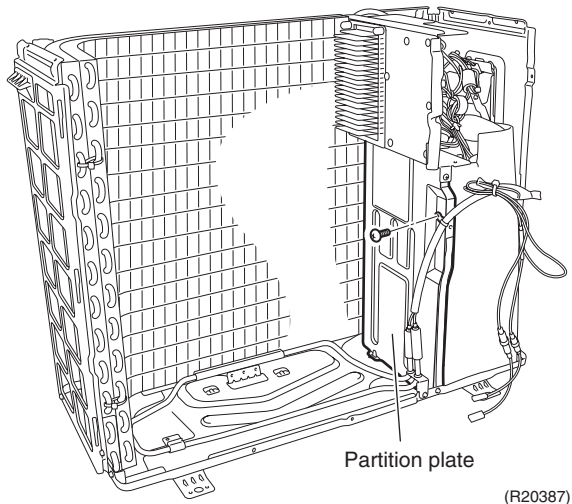
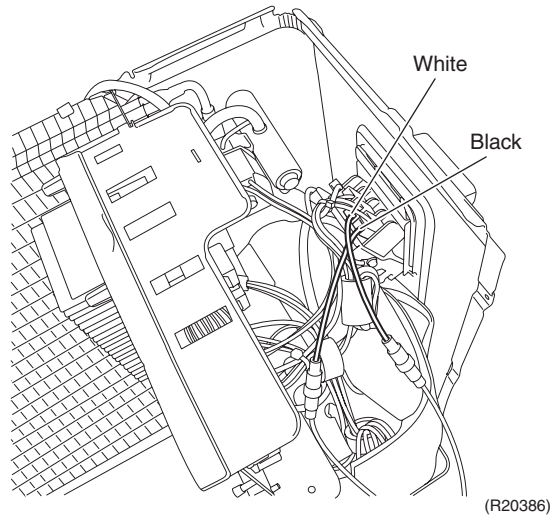

Step	Procedure	Points
4	Lift the outdoor heat exchanger slightly upward and pull the drain pan heater forward to remove it.	■ Be careful not to get cut by heat exchanger fins.

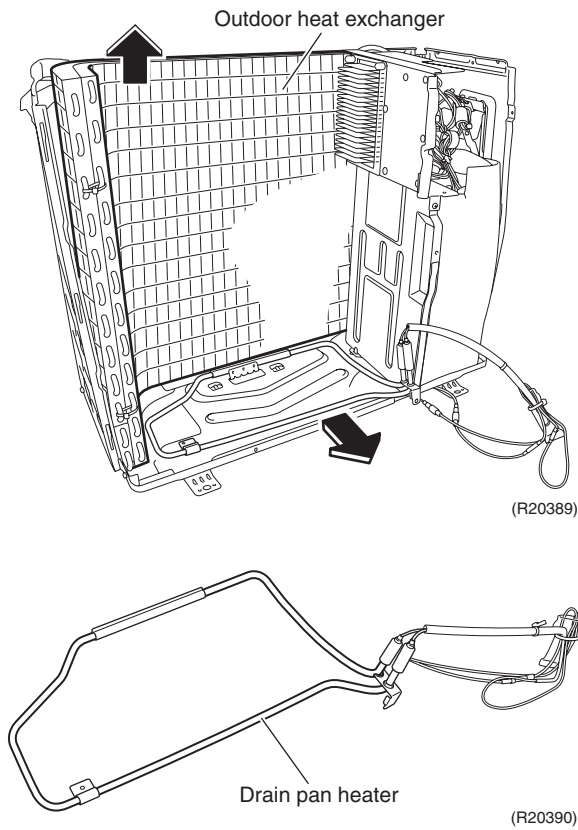

4. Electrical Box / PCB



Warning

◆ Be sure to wait for 10 minutes or more after turning off all power supplies before disassembling work.

Step	Procedure	Points
1. Remove the electrical box.	<p>Clamp Connector</p> <p>(R20391)</p>	<p>1: black, front 2: white, front 3: red, front</p> <ul style="list-style-type: none"> ■ When reassembling, wind the earth / ground wire around other wires and fix them with a clamp. ■ Make sure the wires do not touch the four way valve.
2. Remove the screw and detach the earth / ground wire.	<p>Earth / ground wire</p> <p>(R20392)</p>	<p>Four way valve</p> <p>Earth / ground wire (R20393)</p>
3. Disconnect the connector [S80].	<p>[S80]</p> <p>(R20394)</p>	<p>[S80]: four way valve coil</p>

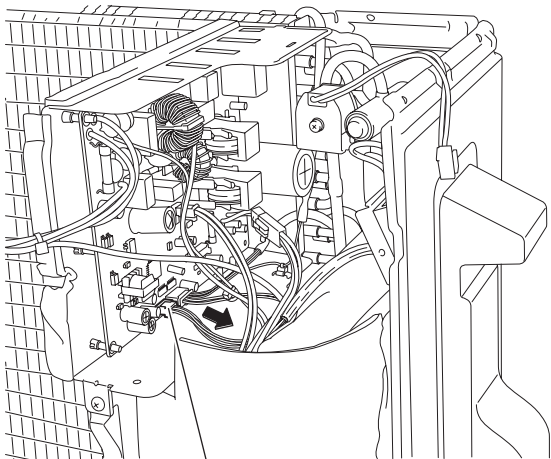
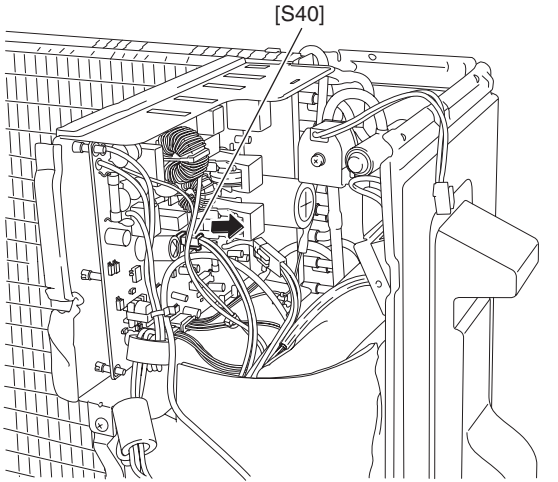
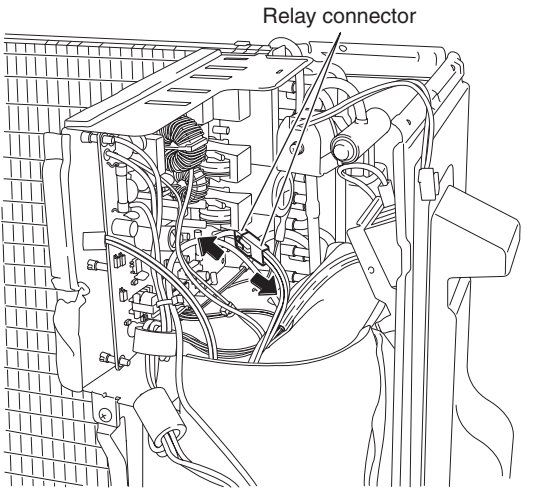
Step	Procedure	Points
4	Disconnect the connector [S20].	[S20]: electronic expansion valve coil
	 <p data-bbox="692 712 743 734">[S20]</p> <p data-bbox="995 712 1062 734">(R20395)</p>	
5	Disconnect the connector [S40].	[S40]: overload protector
	 <p data-bbox="772 792 823 815">[S40]</p> <p data-bbox="995 1272 1062 1294">(R20396)</p>	
6	Disconnect the relay connector for compressor.	
	 <p data-bbox="778 1346 932 1368">Relay connector</p> <p data-bbox="995 1832 1062 1854">(R20397)</p>	

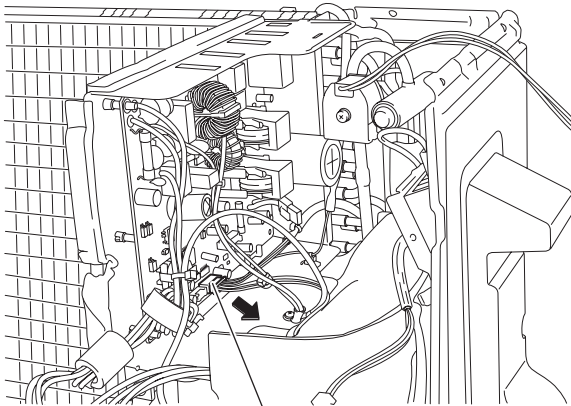
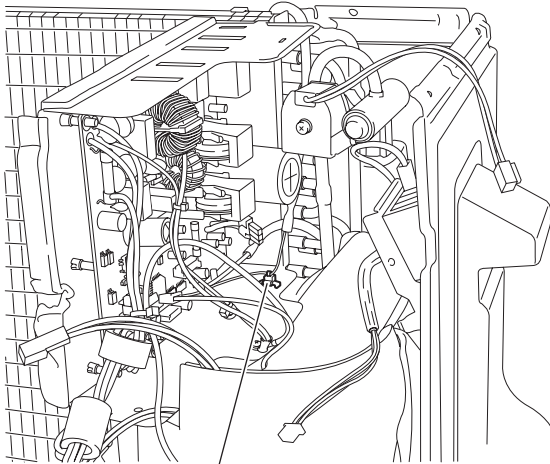
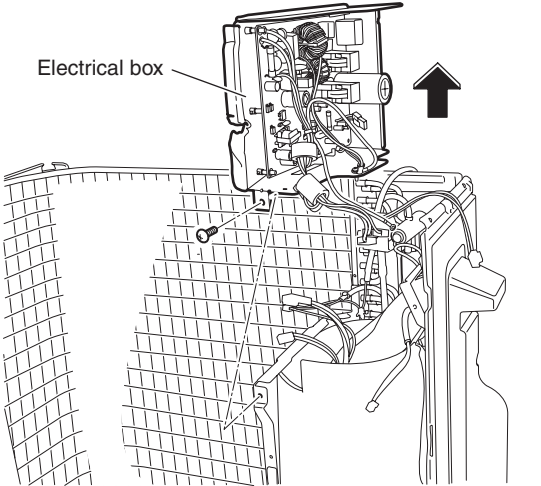
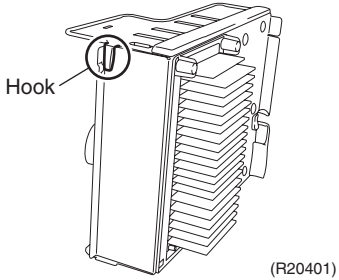
Step	Procedure	Points
7	Disconnect the connector [S90].	[S90]: thermistors
	 <p>[S90] (R20398)</p>	
8	Pull out the clamp from the bottom.	
	 <p>Clamp (R20399)</p>	
9	Remove the screw and lift up the electrical box to remove it.	<p>■ When reassembling, make sure to catch the hook at the top back of the electrical box.</p>
	 <p>Electrical box (R20400)</p>	 <p>Hook (R20401)</p>

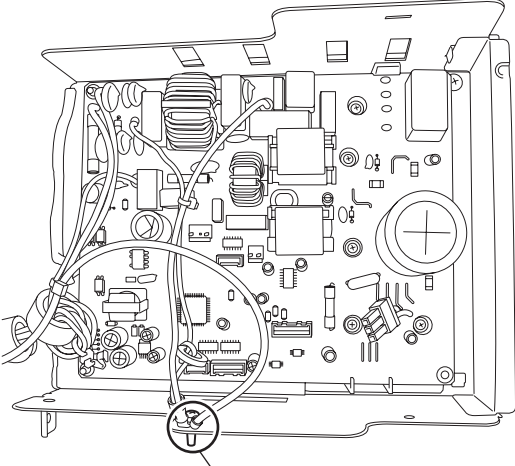
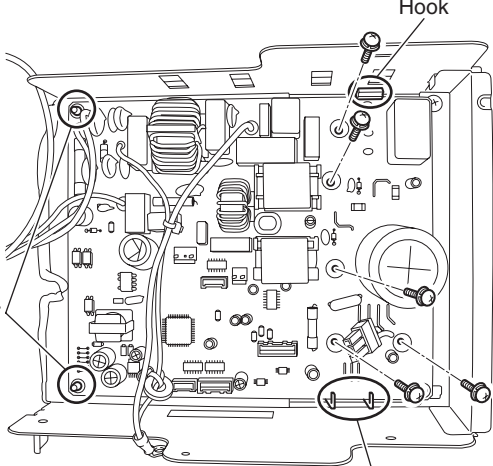
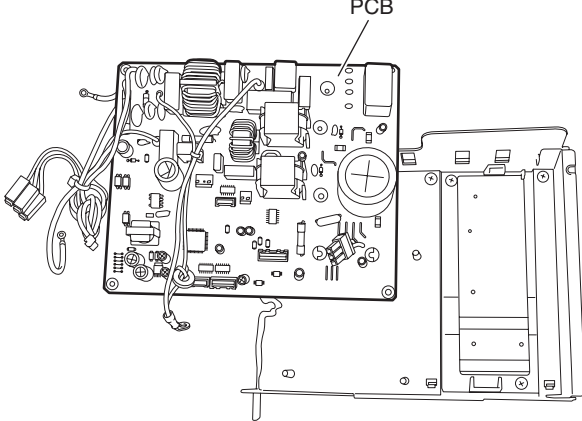
Step	Procedure	Points
2. Remove the PCB.	 <p data-bbox="635 712 831 741">Earth / ground screw</p> <p data-bbox="995 719 1066 741">(R20402)</p>	
<p data-bbox="150 770 448 831">2 Remove the 5 screws of the PCB.</p> <p data-bbox="150 869 464 965">3 Unfasten the 2 spacers and the 3 hooks from the PCB.</p>	 <p data-bbox="963 792 1018 815">Hook</p> <p data-bbox="496 1093 564 1115">Spacer</p> <p data-bbox="916 1272 986 1294">Hook</p> <p data-bbox="995 1279 1066 1301">(R20403)</p>	
4 Remove the PCB.	 <p data-bbox="836 1352 884 1375">PCB</p> <p data-bbox="995 1771 1066 1794">(R20404)</p>	

5. Thermistor ASSY



Warning

◆ Be sure to wait for 10 minutes or more after turning off all power supplies before disassembling work.

Step	Procedure	Points
1	Remove the screw of the stop valve cover.	
2	Slide the stop valve cover downward and remove it.	<ul style="list-style-type: none"> ■ When reassembling, make sure that the 4 hooks are securely fastened.
3	Remove the 2 screws and lift up the protection plate to remove it.	<ul style="list-style-type: none"> ■ When reassembling, make sure to fit the 2 hooks at the back of the protection plate.

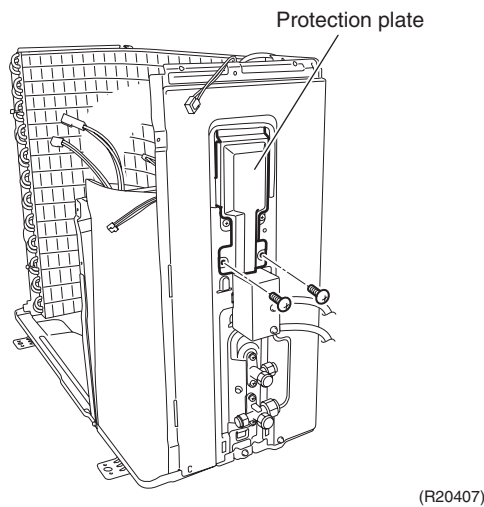
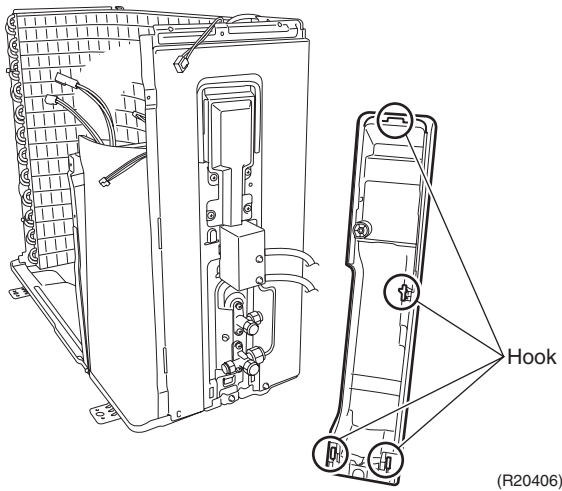
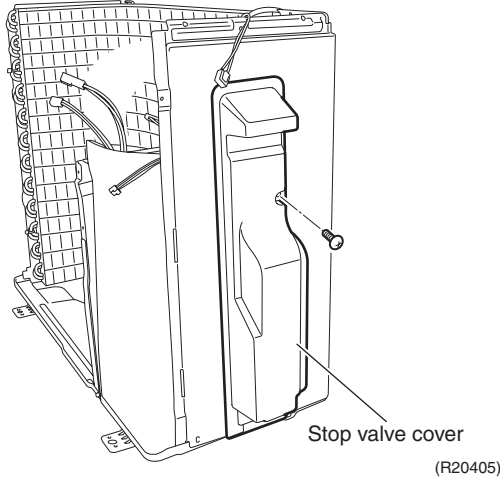

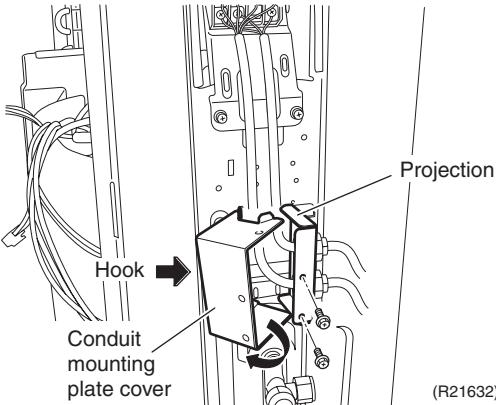
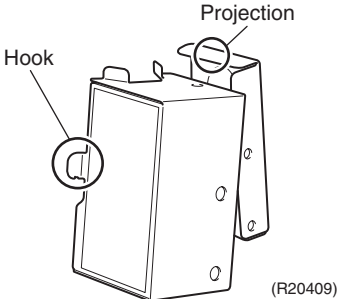
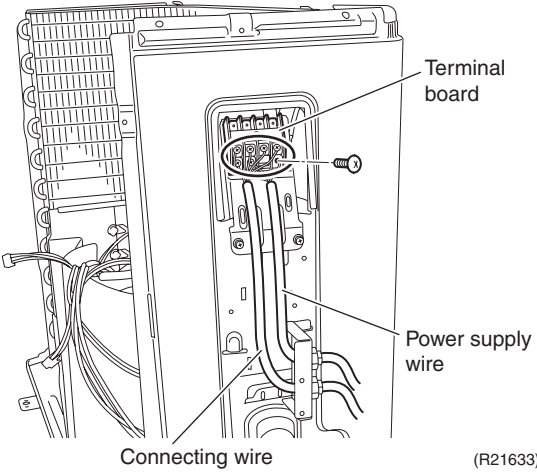
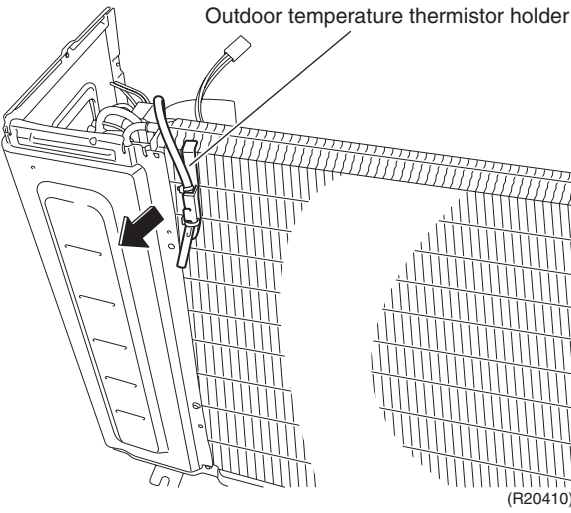
Step	Procedure	Points
4	Remove the 2 screws and open the conduit mounting plate cover to the left, then remove it.	<ul style="list-style-type: none"> ■ The conduit mounting plate cover has a hook on the left and a projection on top. Be sure to catch them all when reassembling.
	 <p>(R21632)</p>	 <p>(R20409)</p>
5	Remove the 7 screws on the terminal board and disconnect the connecting wire and the power supply wire.	
	 <p>(R21633)</p>	
6	Pull out the outdoor temperature thermistor holder.	
	 <p>(R20410)</p>	

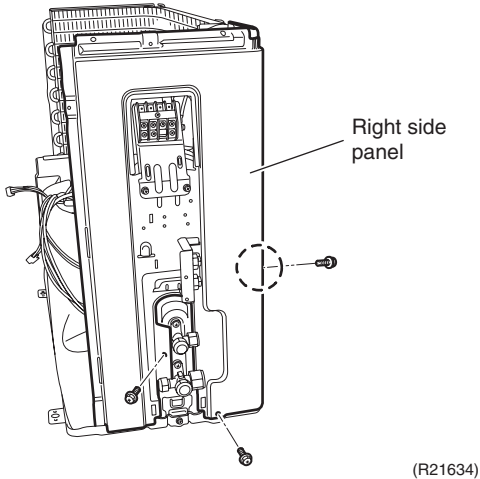
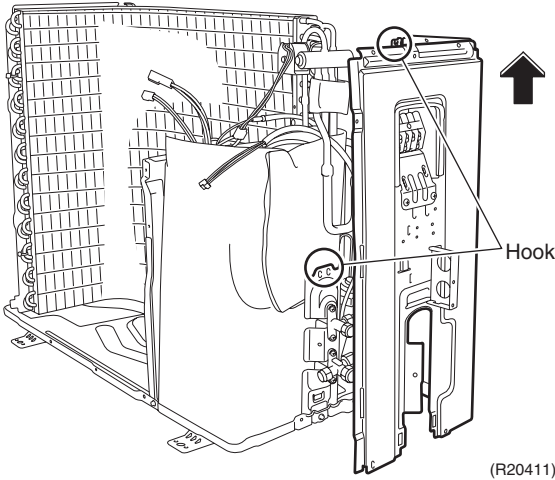
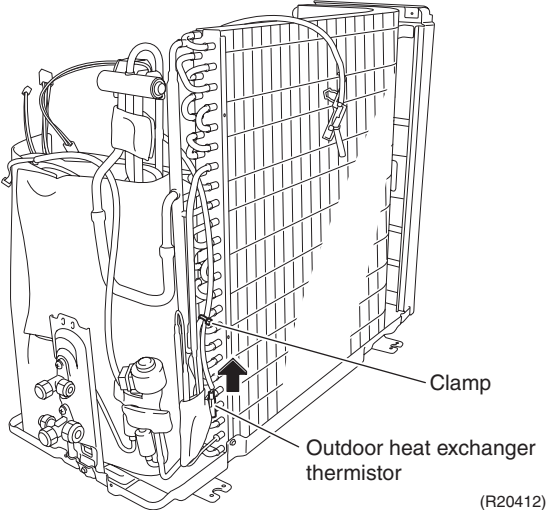
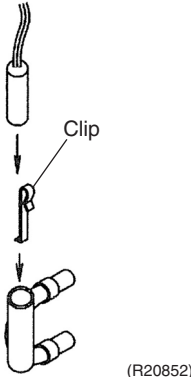
Step	Procedure	Points
7	Remove the 3 screws of the right side panel.	
		
8	Slide up the right side panel to unfasten the 2 hooks.	
9	Remove the right side panel.	
		<ul style="list-style-type: none"> ■ When reassembling, make sure that the 2 hooks are securely fastened.
10	Cut the clamp.	
11	Pull out the outdoor heat exchanger thermistor.	
		<ul style="list-style-type: none"> ■ Be careful not to lose the clip for the thermistor.
		

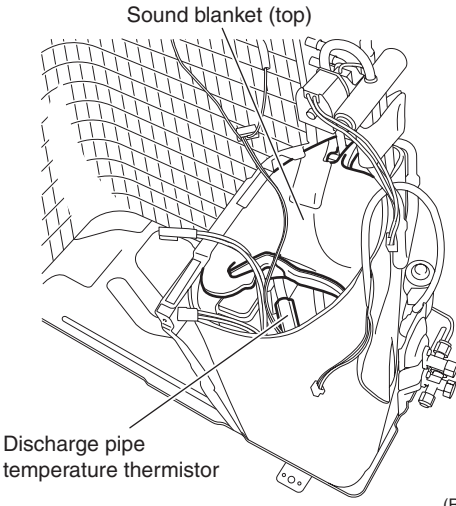
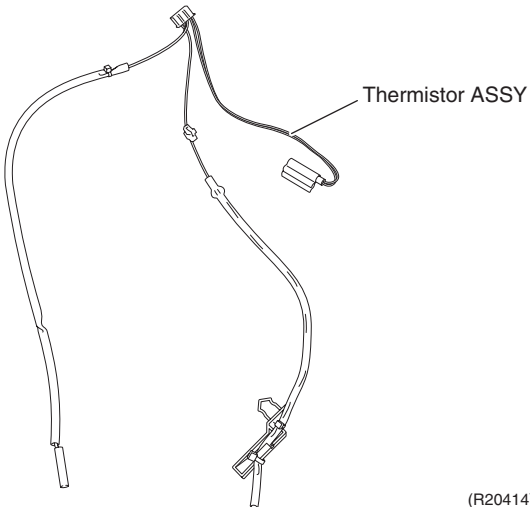
Step	Procedure	Points
12	<p>Open the sound blanket (top) and pull out the discharge pipe temperature thermistor.</p>	<p>■ Be careful not to lose the fixture for the thermistor.</p> 
13	<p>Remove the thermistor ASSY.</p>	

6. Sound Blankets / Partition Plate



Warning

◆ Be sure to wait for 10 minutes or more after turning off all power supplies before disassembling work.

Step	Procedure	Points
1. Remove the sound blankets.		
1 Remove the sound blanket (top).	<p style="text-align: right;">(R20415)</p>	<p>■ Since the piping ports on the sound blanket are torn easily, remove the blanket carefully.</p>
2 Detach the fastener and pull out the sound blanket (outer).	<p style="text-align: right;">(R20416)</p>	
3 Pull out the sound blanket (inner).	<p style="text-align: right;">(R20417)</p>	

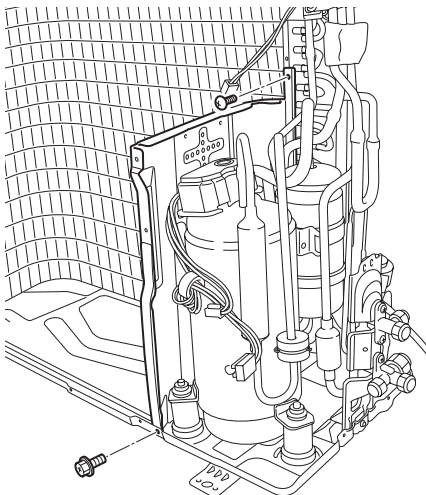
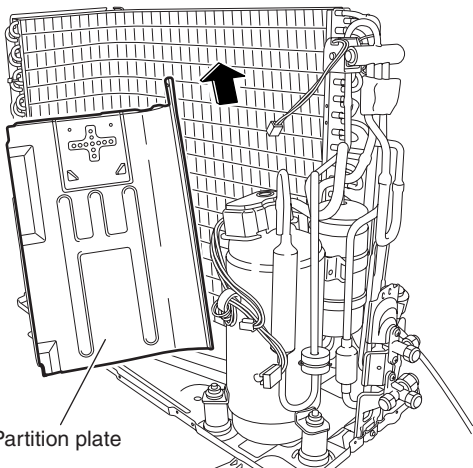
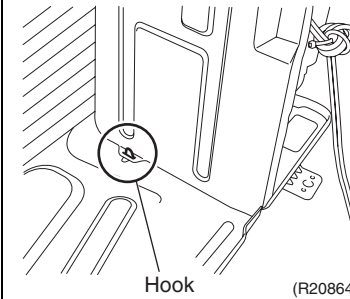
Step	Procedure	Points
2. Remove the partition plate.	 <p>(R20418)</p>	<p>■ When reassembling, fit the hook on the bottom frame.</p>
1 Remove the 2 screws.	 <p>Partition plate</p> <p>(R20419)</p>	 <p>Hook</p> <p>(R20864)</p>

7. Electronic Expansion Valve Coil / Four Way Valve



Warning

- ◆ Be sure to wait for 10 minutes or more after turning off all power supplies before disassembling work.
- ◆ Be careful not to get yourself burnt with the pipes and other parts that are heated by the gas brazing machine.
- ◆ If the refrigerant gas leaks during work, ventilate the room. (If the refrigerant gas is exposed to flames, toxic gas may be generated.)



Caution

- ◆ From the viewpoint of global environment protection, do not discharge the refrigerant gas in the atmosphere. Make sure to collect all the refrigerant gas.
- ◆ Cautions for restoration
 1. Restore the piping by non-oxidation brazing.
 2. It is required to prevent the carbonization of the oil inside the four way valve and the deterioration of the gaskets affected by heat. (Keep below 120°C (248°F).) For the sake of this, wrap the four way valve with wet cloth and provide water so that the cloth does not dry.



Note

- ◆ Before working, make sure that the refrigerant gas is empty in the circuit.
- ◆ Be sure to apply nitrogen replacement when heating up the brazed part.
- ◆ Do not use a metal saw for cutting pipes by all means because the sawdust comes into the circuit.
- ◆ When withdrawing the pipes, be careful not to pinch them firmly with pliers. The pipes may get deformed.
- ◆ Provide a protective sheet or a steel plate so that the brazing flame cannot influence peripheries.
- ◆ Be careful so as not to burn the compressor terminals, the name plate, the outdoor heat exchanger fin.
- ◆ In case of difficulty with gas brazing machine
 1. Disconnect the brazed part where is easy to disconnect and restore.
 2. Cut pipes on the main unit with a tube cutter in order to make it easy to disconnect.

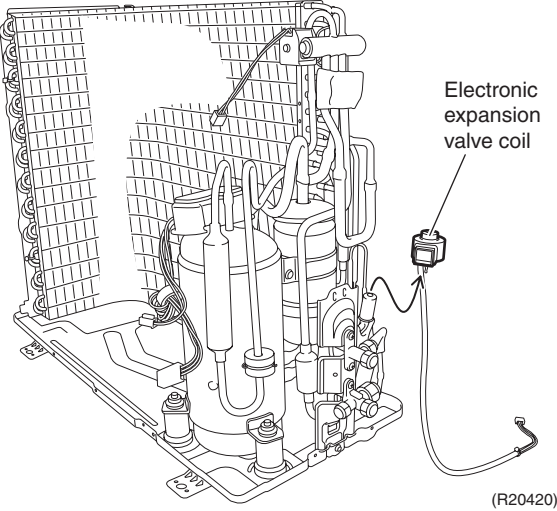
Step	Procedure	Points
<p>1</p>	<p>Pull out the electronic expansion valve coil.</p> 	

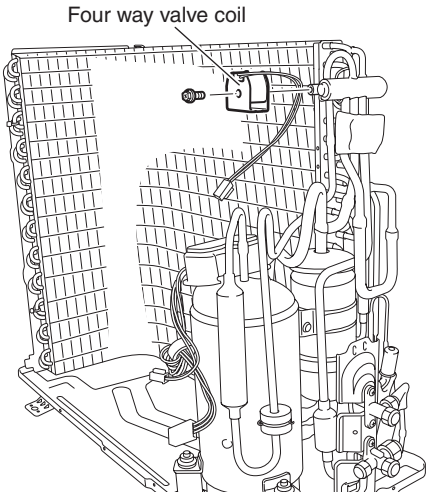
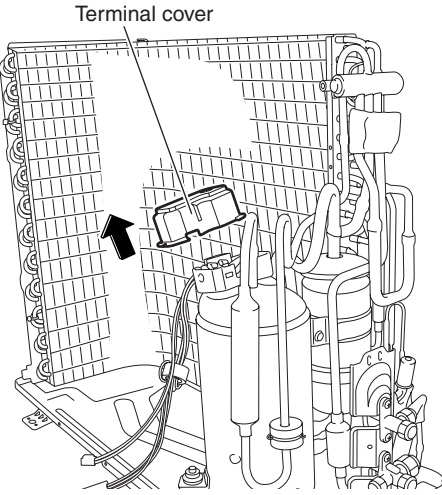
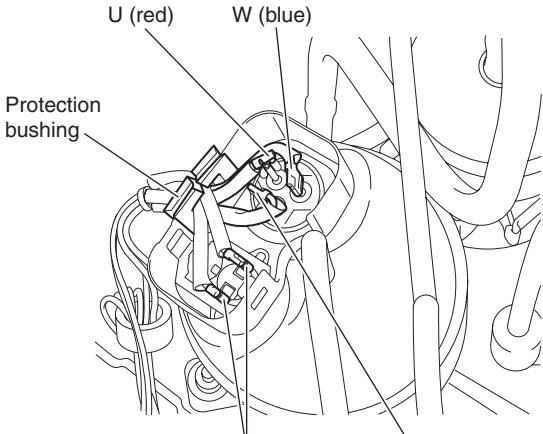
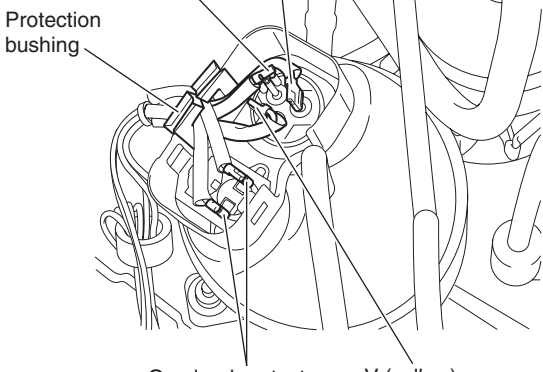
Step	Procedure	Points
2	Remove the screw and remove the four way valve coil.	 <p style="text-align: right;">(R20421)</p>
3	Remove the terminal cover.	 <p style="text-align: right;">(R20422)</p>
4	Remove the protection bushing.	 <p style="text-align: right;">(R20423)</p>
5	Disconnect the compressor lead wires and the overload protector.	 <p style="text-align: right;">(R20423)</p>

Step	Procedure	Points
6	Remove the putty.	
7	Heat up the 4 brazed parts and remove the four way valve.	

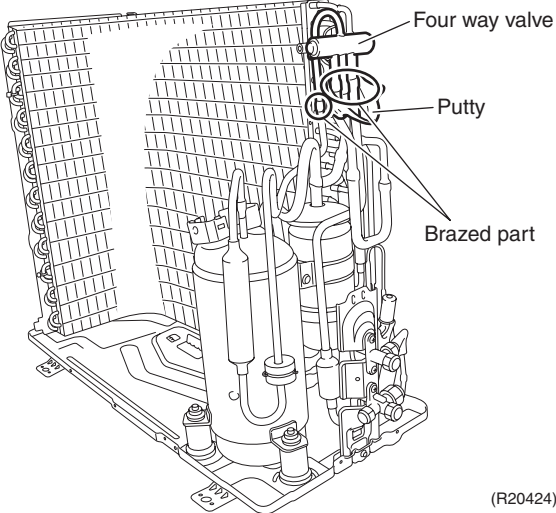

8. Compressor



Warning

- ◆ Be sure to wait for 10 minutes or more after turning off all power supplies before disassembling work.
- ◆ Be careful not to get yourself burnt with the pipes and other parts that are heated by the gas brazing machine.
- ◆ If the refrigerant gas leaks during work, ventilate the room. (If the refrigerant gas is exposed to flames, toxic gas may be generated.)
- ◆ Since it may happen that the refrigerant oil in the compressor catches fire, prepare wet cloth so as to extinguish fire immediately.



Caution

- ◆ From the viewpoint of global environment protection, do not discharge the refrigerant gas in the atmosphere. Make sure to collect all the refrigerant gas.
- ◆ Restore the piping by non-oxidation brazing.



Note

- ◆ Before working, make sure that the refrigerant gas is empty in the circuit.
- ◆ Be sure to apply nitrogen replacement when heating up the brazed part.
- ◆ Do not use a metal saw for cutting pipes by all means because the sawdust comes into the circuit.
- ◆ When withdrawing the pipes, be careful not to pinch them firmly with pliers. The pipes may get deformed.
- ◆ Provide a protective sheet or a steel plate so that the brazing flame cannot influence peripheries.
- ◆ Be careful so as not to burn the compressor terminals, the name plate, the outdoor heat exchanger fin.
- ◆ In case of difficulty with gas brazing machine
 1. Disconnect the brazed part where is easy to disconnect and restore.
 2. Cut pipes on the main unit with a tube cutter in order to make it easy to disconnect.

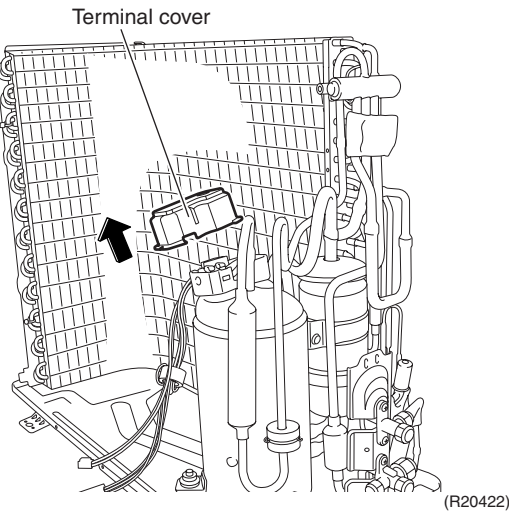
Step	Procedure	Points
1	Remove the terminal cover. 	

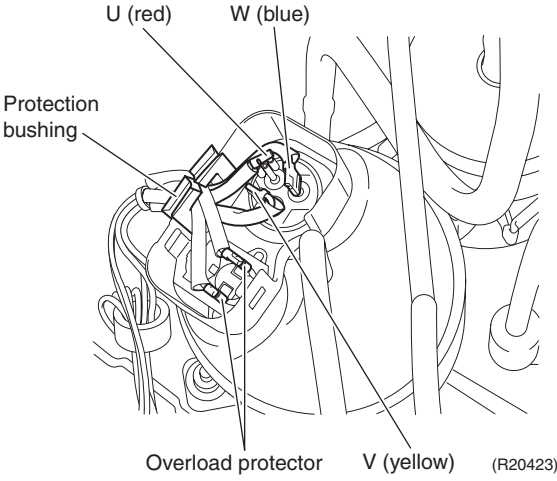
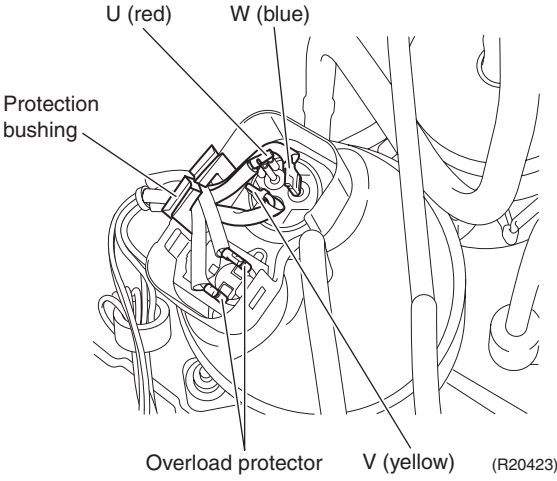
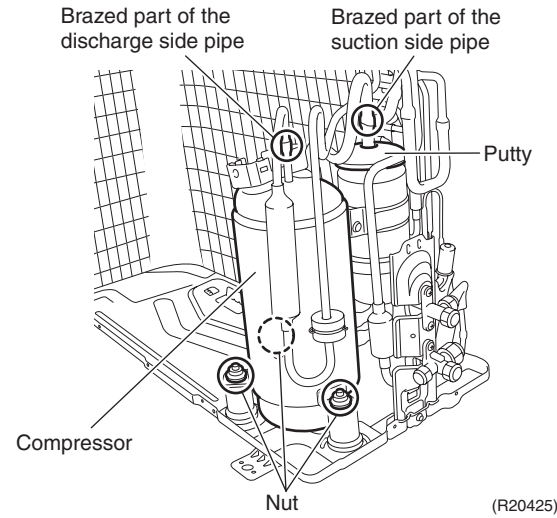
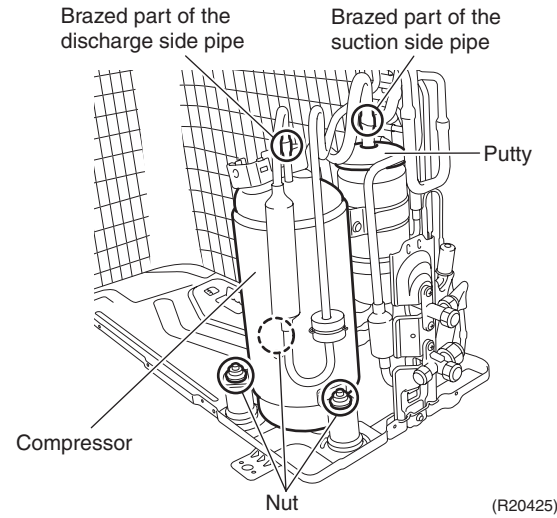
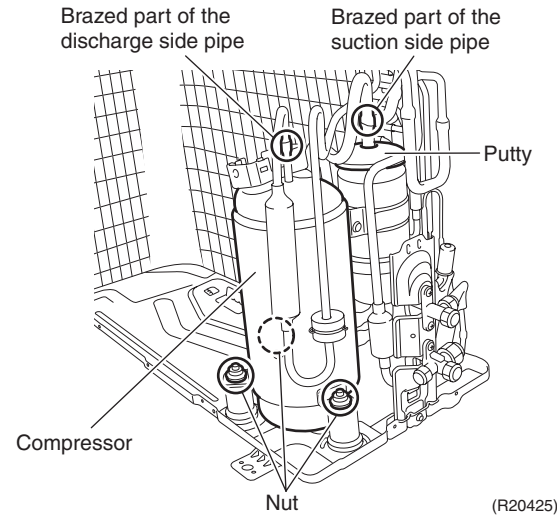
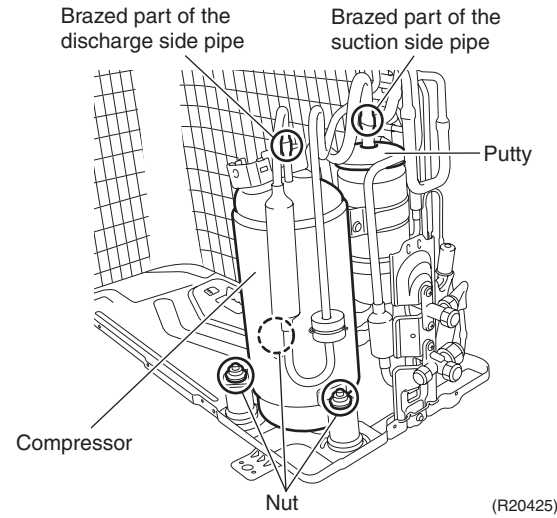
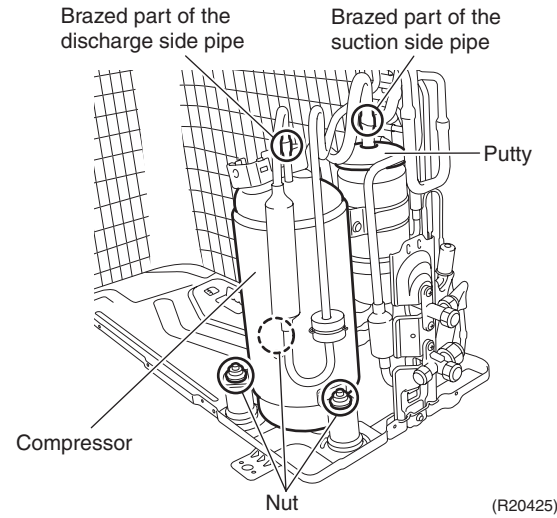
Step		Procedure	Points
2	Remove the protection bushing.	 <p>U (red) W (blue)</p> <p>Protection bushing</p> <p>Overload protector V (yellow) (R20423)</p>	
3	Disconnect the compressor lead wires and the overload protector.	 <p>U (red) W (blue)</p> <p>Protection bushing</p> <p>Overload protector V (yellow) (R20423)</p>	
4	Remove the putty.	 <p>Brazed part of the discharge side pipe Brazed part of the suction side pipe</p> <p>Putty</p> <p>Compressor</p> <p>Nut (R20425)</p>	
5	Heat up the brazed part of the discharge side pipe and disconnect it.	 <p>Brazed part of the discharge side pipe Brazed part of the suction side pipe</p> <p>Putty</p> <p>Compressor</p> <p>Nut (R20425)</p>	
6	Heat up the brazed part of the suction side pipe and disconnect it.	 <p>Brazed part of the discharge side pipe Brazed part of the suction side pipe</p> <p>Putty</p> <p>Compressor</p> <p>Nut (R20425)</p>	
7	Remove the 3 nuts of the compressor.	 <p>Brazed part of the discharge side pipe Brazed part of the suction side pipe</p> <p>Putty</p> <p>Compressor</p> <p>Nut (R20425)</p>	
8	Lift up the compressor and remove it.	 <p>Brazed part of the discharge side pipe Brazed part of the suction side pipe</p> <p>Putty</p> <p>Compressor</p> <p>Nut (R20425)</p>	

Revision History

Month / Year	Version	Revised contents
03 / 2016	Si001655E	First edition

Warning



- Daikin products are manufactured for export to numerous countries throughout the world. Prior to purchase, please confirm with your local authorised importer, distributor and/or retailer whether this product conforms to the applicable standards, and is suitable for use, in the region where the product will be used. This statement does not purport to exclude, restrict or modify the application of any local legislation.
- Ask a qualified installer or contractor to install this product. Do not try to install the product yourself. Improper installation can result in water or refrigerant leakage, electrical shock, fire or explosion.
- Use only those parts and accessories supplied or specified by Daikin. Ask a qualified installer or contractor to install those parts and accessories. Use of unauthorised parts and accessories or improper installation of parts and accessories can result in water or refrigerant leakage, electrical shock, fire or explosion.
- Read the user's manual carefully before using this product. The user's manual provides important safety instructions and warnings. Be sure to follow these instructions and warnings.

If you have any enquiries, please contact your local importer, distributor and/or retailer.

Cautions on product corrosion

1. Air conditioners should not be installed in areas where corrosive gases, such as acid gas or alkaline gas, are produced.
2. If the outdoor unit is to be installed close to the sea shore, direct exposure to the sea breeze should be avoided. If you need to install the outdoor unit close to the sea shore, contact your local distributor.

Dealer

DAIKIN INDUSTRIES, LTD.

Head Office:
Umeda Center Bldg., 2-4-12, Nakazaki-Nishi,
Kita-ku, Osaka, 530-8323 Japan

Tokyo Office:
JR Shinagawa East Bldg., 2-18-1, Konan,
Minato-ku, Tokyo, 108-0075 Japan

<http://www.daikin.com/products/ac/>

©All rights reserved