





Si001556E

REMOVAL PROCEDURE



S E R V I C E M A N U A L

18000 Btu/h Class

-  Outdoor Unit
-  Inverter
-  Pair Type

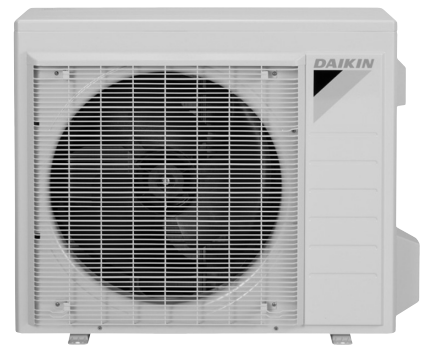

Service Manual Removal Procedure

Outdoor Unit

●Cooling Only
RKN18NMVJU

Table of Contents

1. Outer Panels	2
2. Outdoor Fan / Fan Motor.....	4
3. Electrical Box	7
4. PCB.....	10
5. Thermistor ASSY / Partition Plate	12
6. Sound Blankets	16
7. Electronic Expansion Valve Coil / Compressor.....	17

1. Outer Panels



Warning

♦ Be sure to wait for 10 minutes or more after turning off all power supplies before disassembling work.

Step	Procedure	Points
1	Remove the 6 screws and remove the top panel.	<p>Top panel</p> <p>(R21871)</p>
2	Remove the 8 screws of the front panel.	<p>Front panel</p> <p>(R21872)</p>
3	Slide the fan motor fixing frame to the left and unfasten the 2 hooks.	<p>Fan motor fixing frame</p> <p>Hook</p> <p>(R21873)</p>

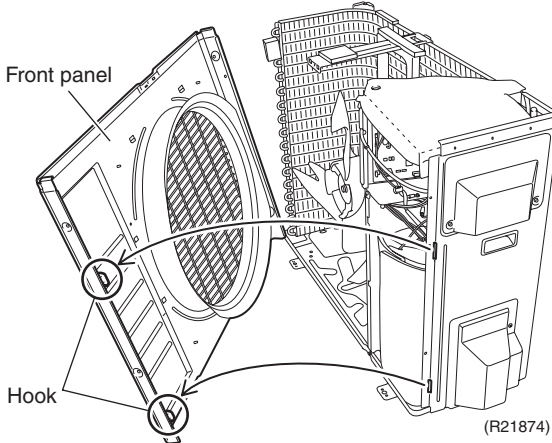
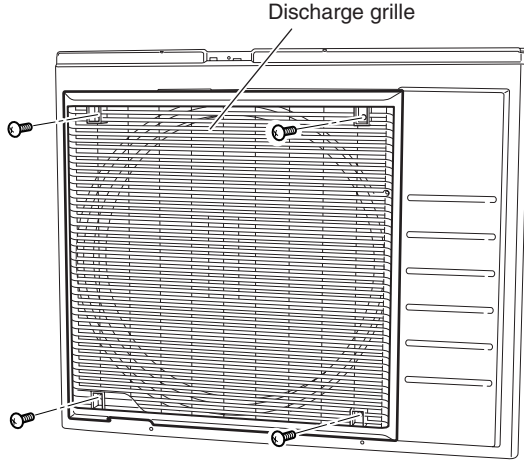
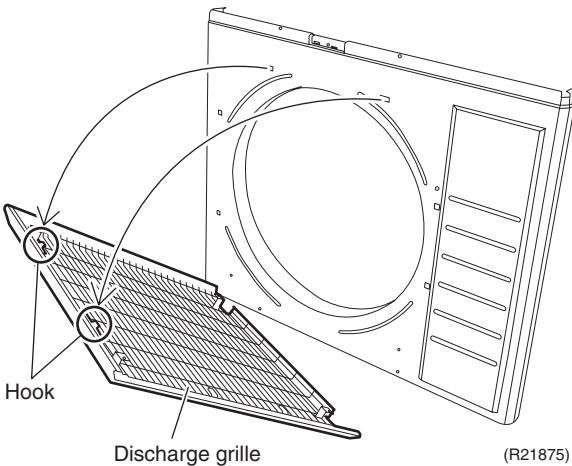
Step		Procedure	Points
4	Unfasten the 2 hooks on the right side.	 <p data-bbox="991 640 1066 663">(R21874)</p>	
5	Remove the front panel.		 <p data-bbox="991 1182 1066 1205">(R20906)</p>
6	Remove the 4 screws of the discharge grille.	 <p data-bbox="991 1697 1066 1720">(R21875)</p>	
7	Unfasten the 2 hooks and remove the discharge grille.		

2. Outdoor Fan / Fan Motor



Warning

- ◆ Be sure to wait for 10 minutes or more after turning off all power supplies before disassembling work.

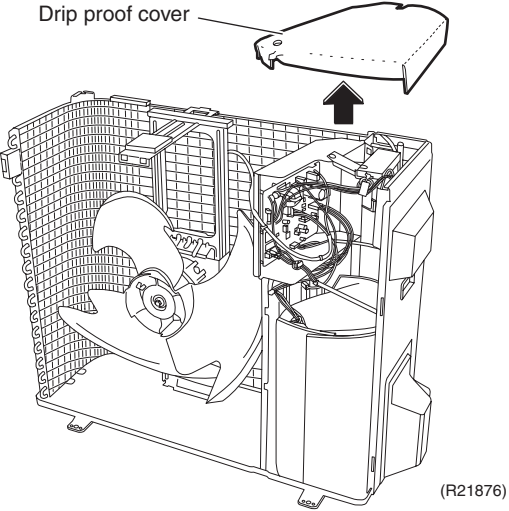
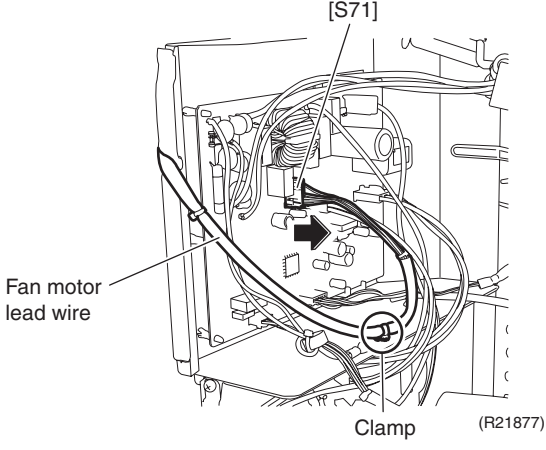
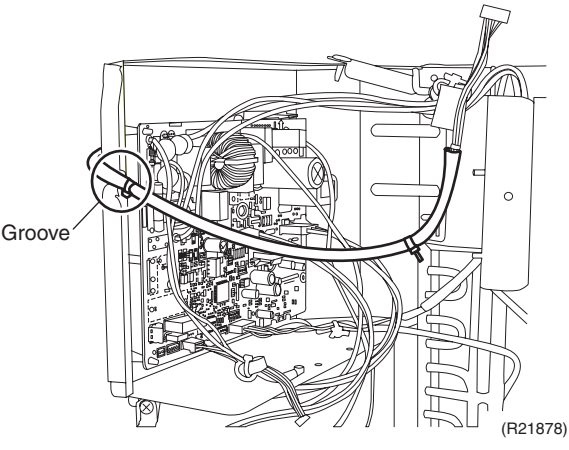
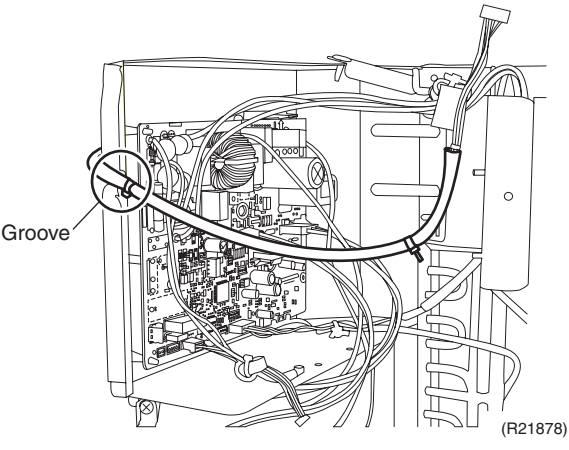
Step	Procedure	Points
1	Remove the drip proof cover.	
2	Disconnect the connector [S71].	
3	Pull out the bottom clamp of the fan motor lead wire.	
4	Release the fan motor lead wire from the groove.	

[S71]: fan motor

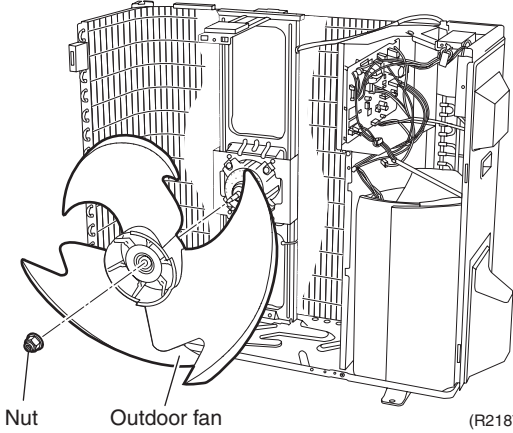
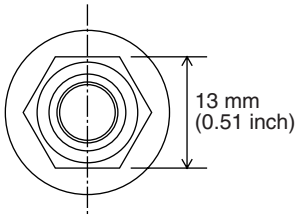
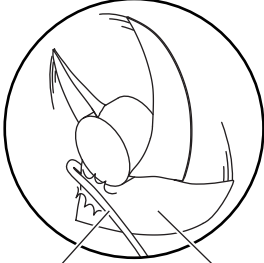
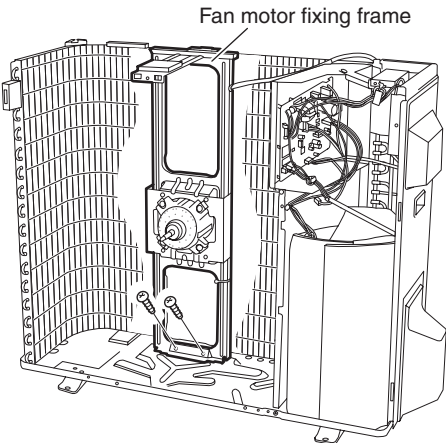
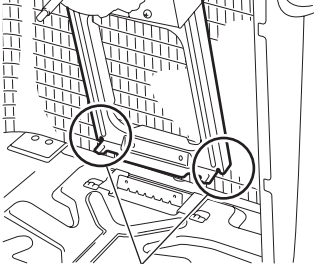
Step		Procedure	Points
5	Remove the nut and remove the outdoor fan.		<ul style="list-style-type: none"> ■ Nut size : M8  <ul style="list-style-type: none"> ■ Align the ▼ mark of the outdoor fan with the D-cut section of the motor shaft when reassembling. ■ When reassembling, put the fan motor lead wire through the back of the fan motor so as not to be entangled with the outdoor fan. 
6	Remove the 2 screws and remove the fan motor fixing frame.		<ul style="list-style-type: none"> ■ When reassembling, fit the 2 lower hooks into the bottom frame. 

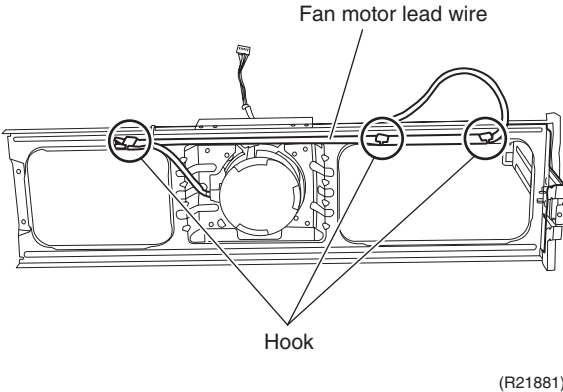
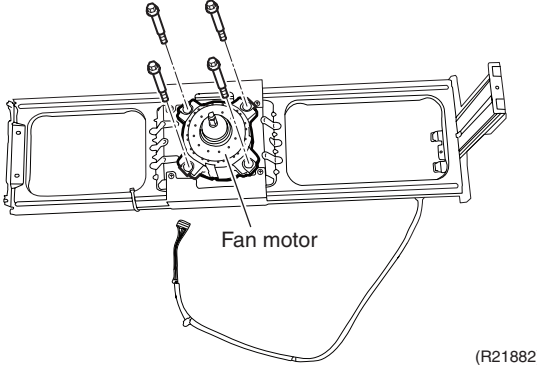
Step	Procedure	Points
7	Unfasten the 3 hooks on the fan motor fixing frame and release the fan motor lead wire.	
	 <p style="text-align: center;">Fan motor lead wire</p> <p style="text-align: center;">Hook</p> <p style="text-align: right;">(R21881)</p>	
8	Remove the 4 screws and remove the fan motor.	
	 <p style="text-align: center;">Fan motor</p> <p style="text-align: right;">(R21882)</p>	

3. Electrical Box



Warning

- ◆ Be sure to wait for 10 minutes or more after turning off all power supplies before disassembling work.

Step	Procedure	Points
1	Remove the 2 screws of the terminal cover.	(R21883)
2	Open the terminal cover and pull down to unfasten the 2 hooks.	(R21884)
3	Remove the terminal cover.	
4	Remove the 7 screws on the terminal board and disconnect the connecting wire and power supply wire.	(R21885)
5	Loosen the 2 lock nuts and remove the 2 conduits.	
6	Remove the connecting wire and power supply wire.	

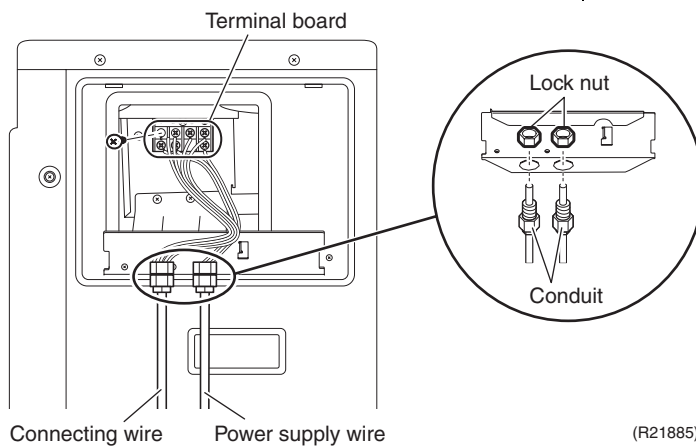
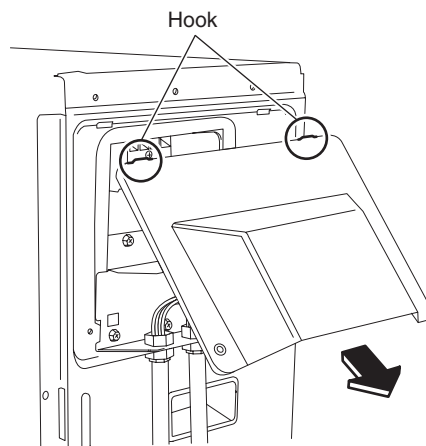
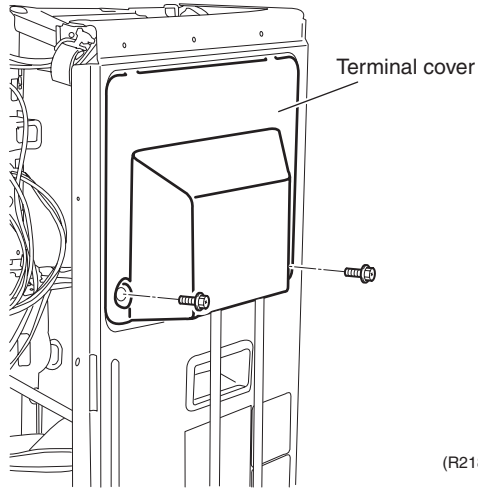

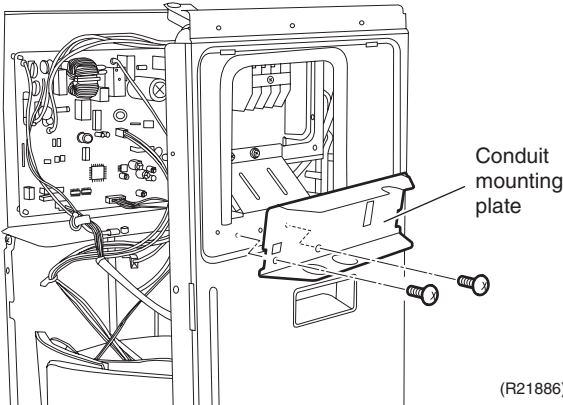
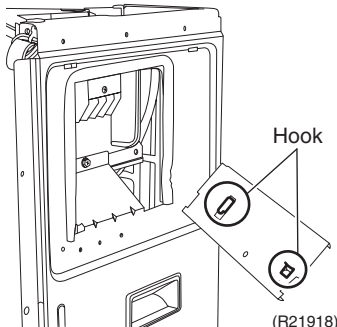
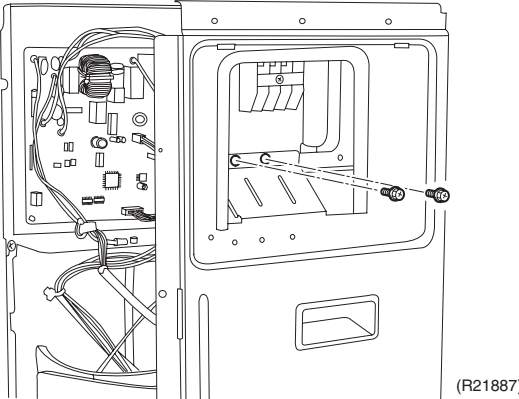
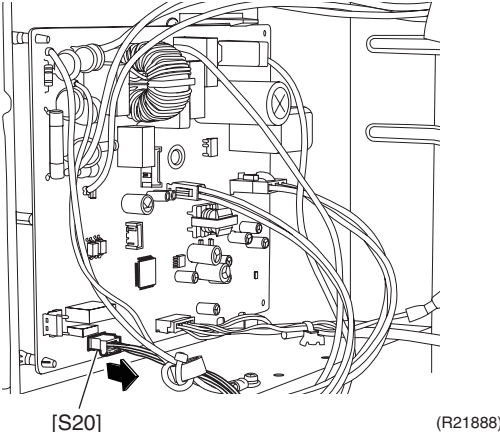
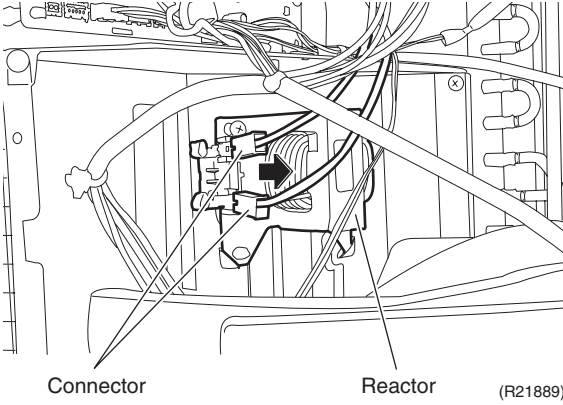
Step	Procedure	Points
7	Remove the 2 screws and remove the conduit mounting plate.	<ul style="list-style-type: none"> When reassembling, be sure to fit the 2 hooks on the conduit mounting plate to the right side panel.
	 <p>Conduit mounting plate</p> <p>(R21886)</p>	 <p>Hook</p> <p>(R21918)</p>
8	Remove the 2 screws.	
	 <p>(R21887)</p>	
9	Disconnect the connector [S20].	[S20]: electronic expansion valve coil
	 <p>[S20]</p> <p>(R21888)</p>	
10	Disconnect the 2 connectors from the reactor.	<ul style="list-style-type: none"> When reassembling, you can reconnect the 2 connectors for the reactor in either way regardless of the color.
	 <p>Connector</p> <p>Reactor</p> <p>(R21889)</p>	

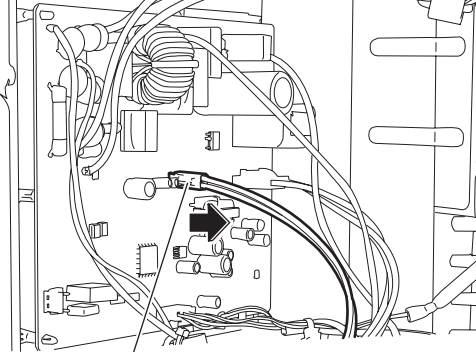
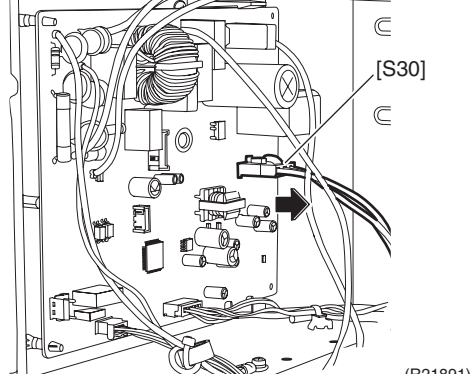
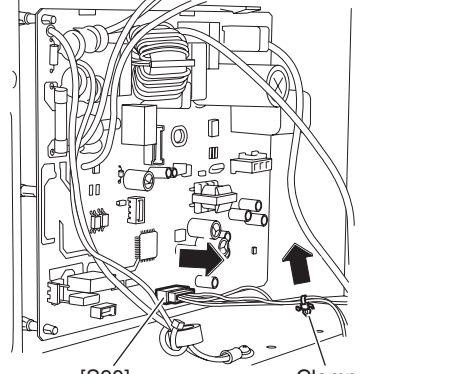
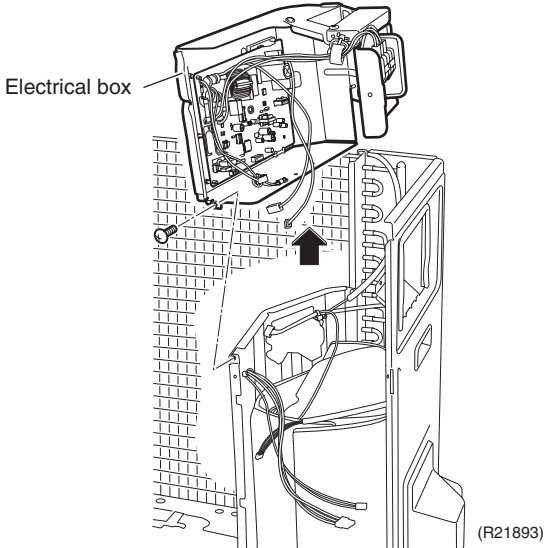
Step	Procedure	Procedure	Points
11	Disconnect the connector [S40].	 <p>[S40] (R21890)</p>	[S40]: overload protector
12	Disconnect the connector [S30].	 <p>[S30] (R21891)</p>	[S30]: compressor motor
13	Disconnect the connector [S90] and pull out the clamp.	 <p>[S90] Clamp (R21892)</p>	[S90]: thermistors
14	Remove the screw and remove the electrical box.	 <p>Electrical box (R21893)</p>	

4. PCB



Warning

♦ Be sure to wait for 10 minutes or more after turning off all power supplies before disassembling work.

Step	Procedure	Points
1	Remove the screw of the terminal board.	
2	Remove the earth / ground screw and pull out the clamp from the mounting plate for terminal board.	
3	Remove the earth / ground screw from the electrical box.	

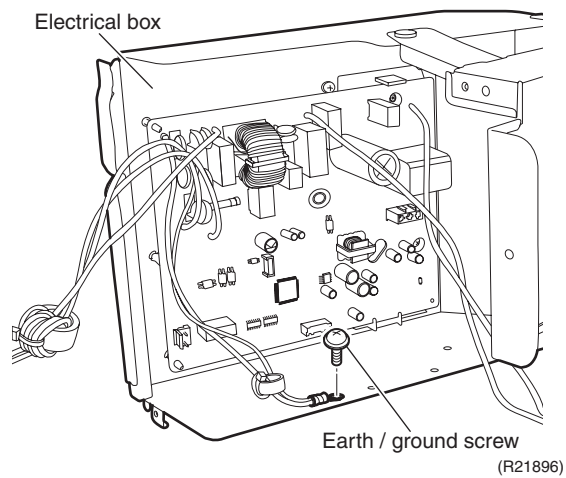
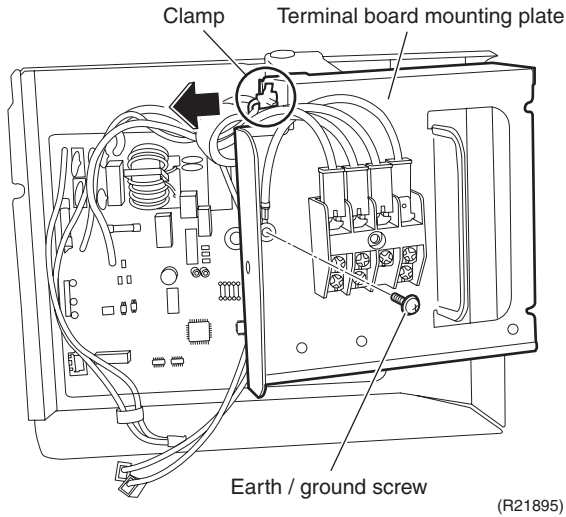
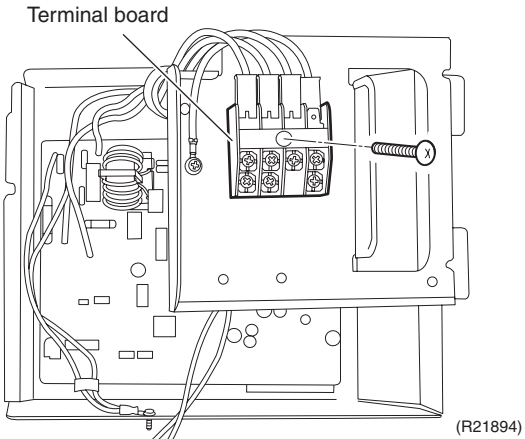

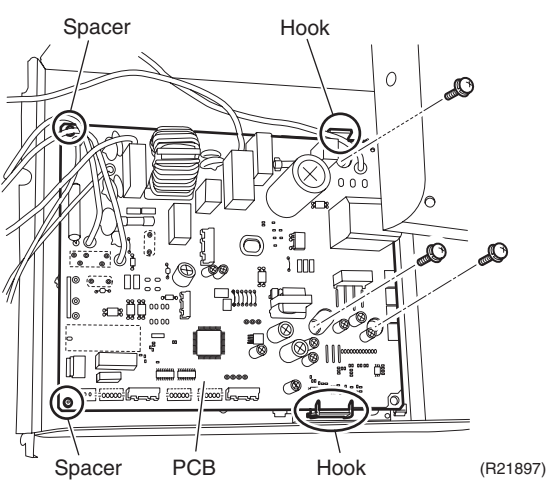
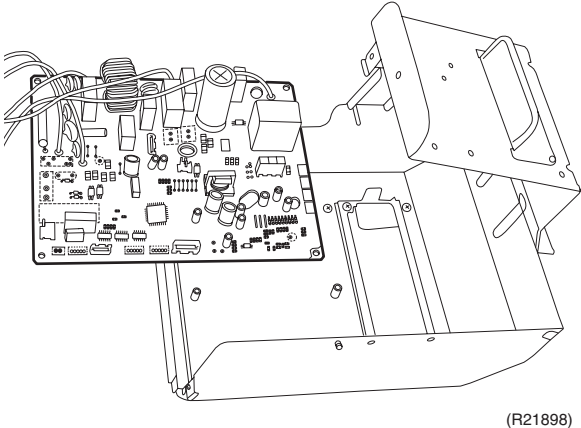
Step	Procedure	Points
4	Remove the 3 screws of the PCB.	<ul style="list-style-type: none"> ■ A long screwdriver is necessary for removing these screws.
5	Unfasten the 2 spacers and the 2 hooks to remove the PCB.	
 <p style="text-align: right;">(R21897)</p>		
 <p style="text-align: right;">(R21898)</p>		

5. Thermistor ASSY / Partition Plate



Warning

◆ Be sure to wait for 10 minutes or more after turning off all power supplies before disassembling work.

Step	Procedure	Points
1	Remove the screw of the stop valve cover.	
2	Slide the stop valve cover downward and remove it.	<p>■ When reassembling, make sure to fit the 3 hooks.</p>
3	Release the outdoor temperature thermistor harness from the slit.	

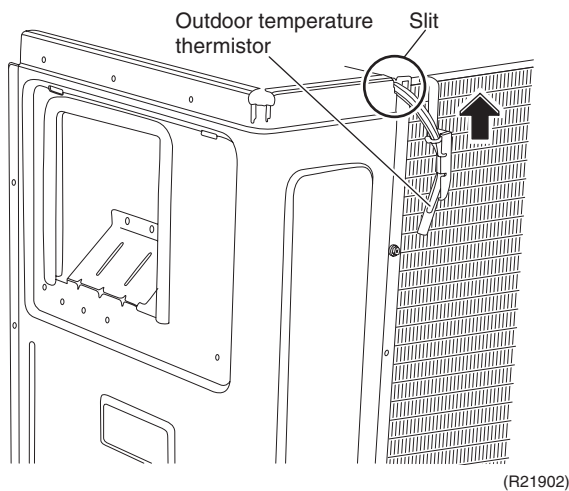
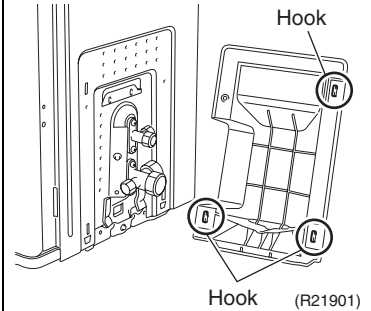
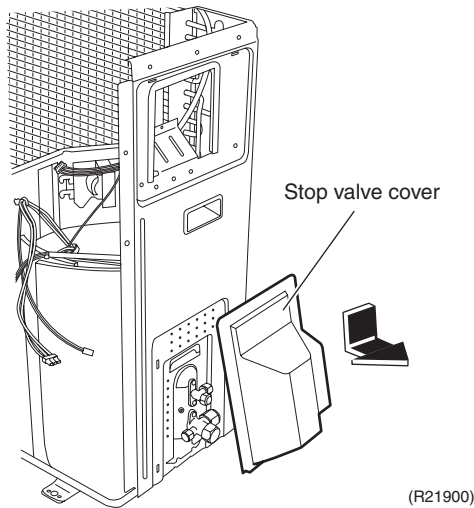
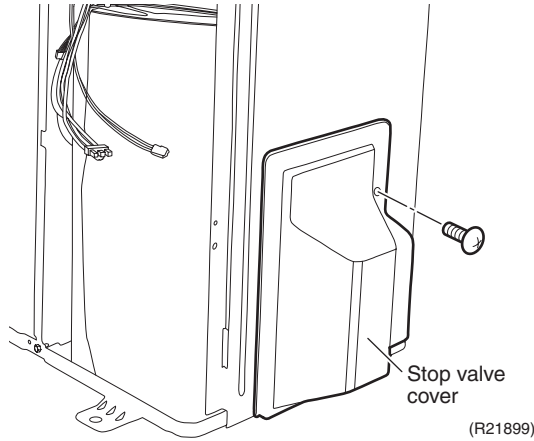

Step	Procedure	Points
4	Remove the 4 screws of the right side panel.	
5	Unfasten the 4 hooks and remove the right side panel.	<ul style="list-style-type: none"> When reassembling, make sure to fit all the hooks.
6	Pull out the outdoor heat exchanger thermistor and cut the clamp.	<ul style="list-style-type: none"> Be careful not to lose the clip for the thermistor.

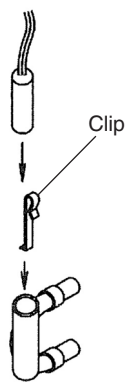
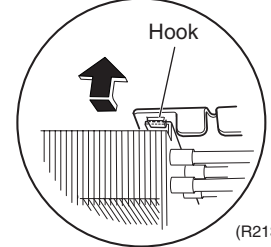
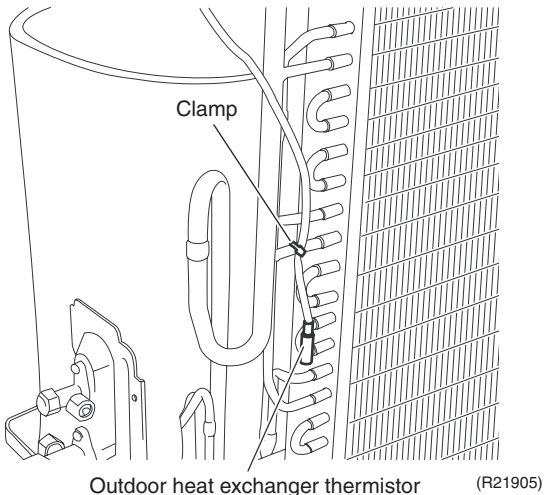
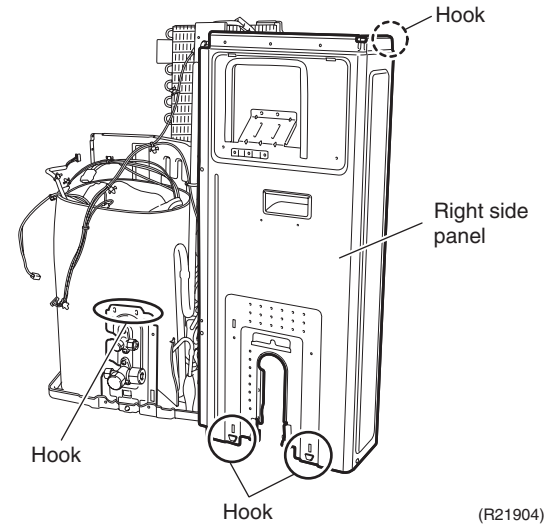
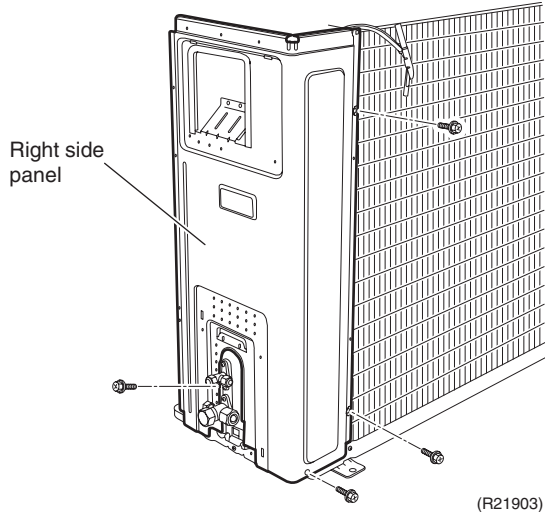

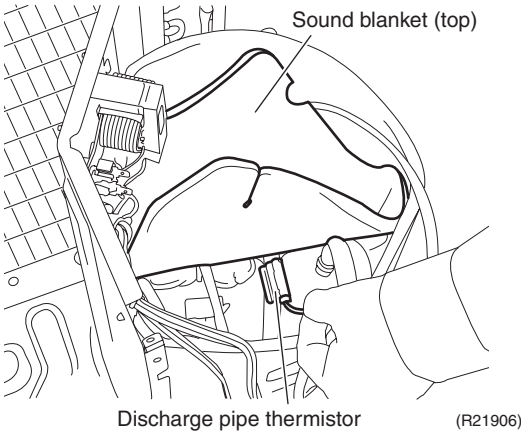
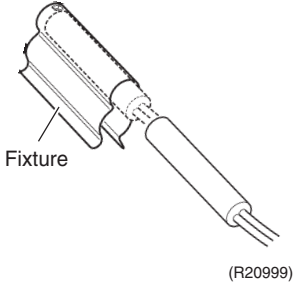
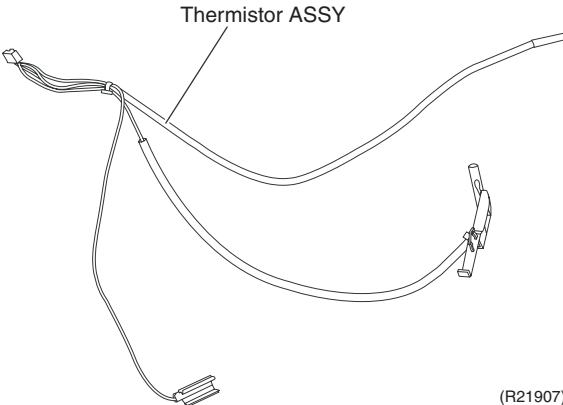
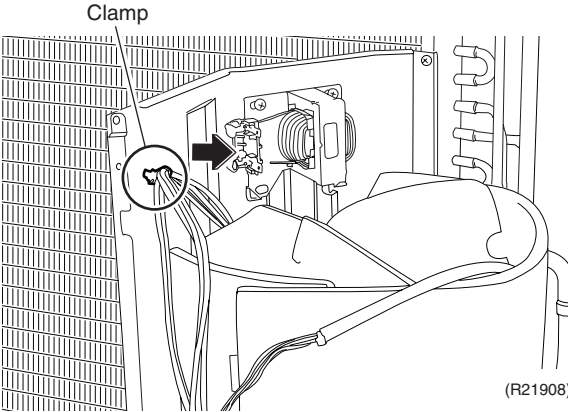
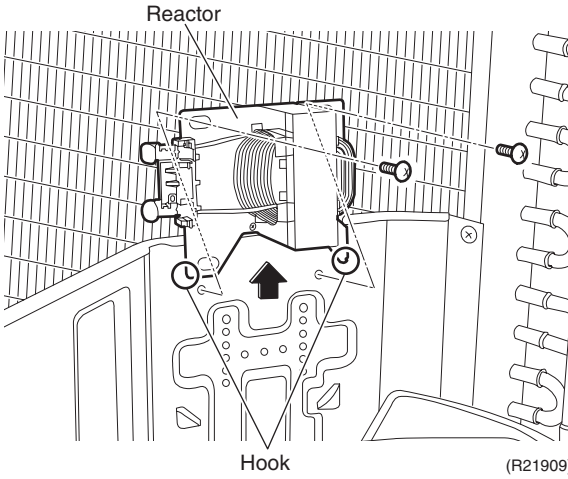
Step	Procedure	Points
7	Open the sound blanket (top) and detach the discharge pipe thermistor.	<ul style="list-style-type: none"> Be careful not to lose the fixture for the thermistor.
		
8	Remove the thermistor ASSY.	
		
9	Pull out the clamp.	
		
10	Remove the 2 screws of the reactor.	
11	Slide the reactor upward to unfasten the 2 hooks.	
12	Remove the reactor.	
		

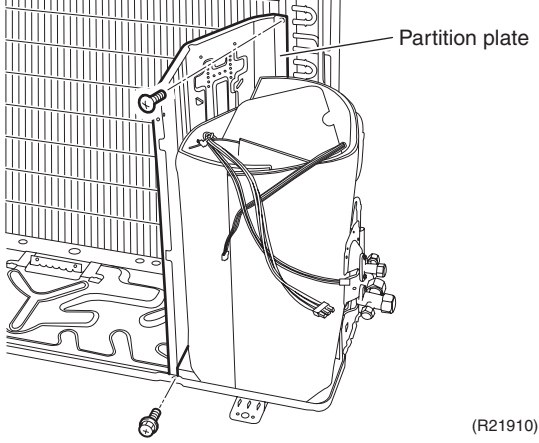
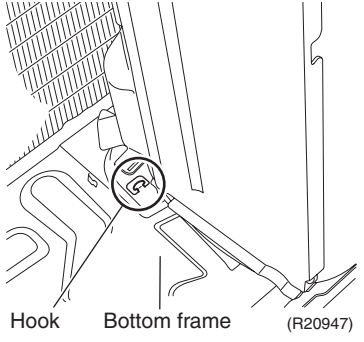
Step	Procedure	Points
13	Remove the 2 screws and remove the partition plate.	<ul style="list-style-type: none"> ■ When reassembling, fit the lower hook into the bottom frame.
	 <p>(R21910)</p>	 <p>Hook Bottom frame (R20947)</p>

6. Sound Blankets



Warning

◆ Be sure to wait for 10 minutes or more after turning off all power supplies before disassembling work.

Step	Procedure	Points
1	Remove the sound blanket (top).	<ul style="list-style-type: none"> ■ Since the piping ports on the sound blanket are torn easily, remove the blanket carefully.
2	Open and pull up the sound blanket (outer).	
3	Remove the sound blanket (inner).	

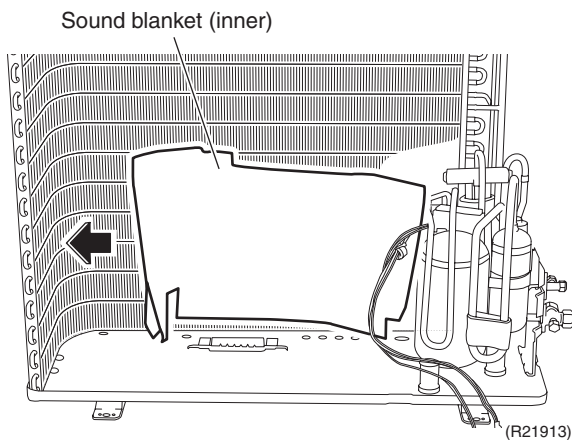
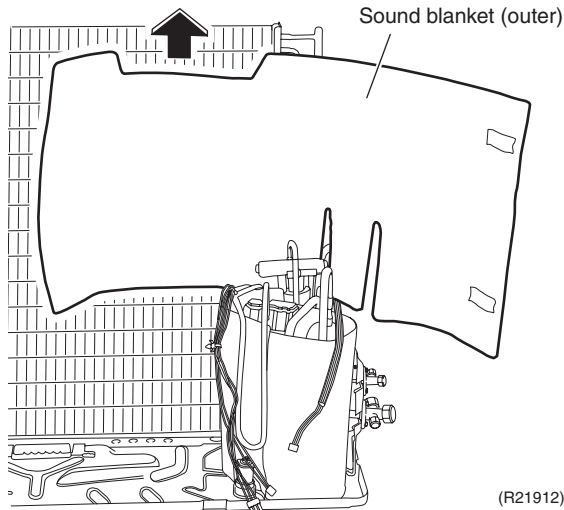
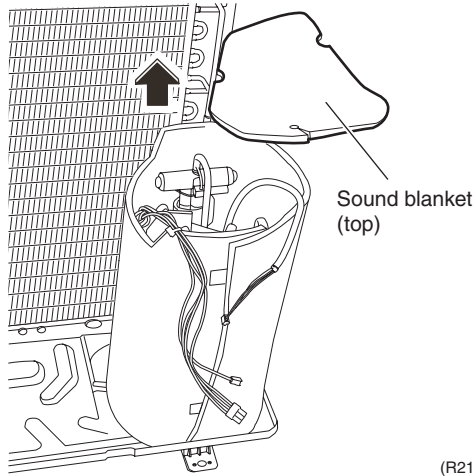

7. Electronic Expansion Valve Coil / Compressor



Warning

- ◆ Be sure to wait for 10 minutes or more after turning off all power supplies before disassembling work.
- ◆ Be careful not to get yourself burnt with the pipes and other parts that are heated by the gas brazing machine.
- ◆ If the refrigerant gas leaks during work, ventilate the room. (If the refrigerant gas is exposed to flames, toxic gas may be generated.)
- ◆ Since it may happen that the refrigerant oil in the compressor catches fire, prepare wet cloth so as to extinguish fire immediately.



Caution

- ◆ From the viewpoint of global environment protection, do not discharge the refrigerant gas in the atmosphere. Make sure to collect all the refrigerant gas.
- ◆ Restore the piping by non-oxidation brazing.



Note

- ◆ Before working, make sure that the refrigerant gas is empty in the circuit.
- ◆ Be sure to apply nitrogen replacement when heating up the brazed part.
- ◆ Do not use a metal saw for cutting pipes by all means because the sawdust comes into the circuit.
- ◆ When withdrawing the pipes, be careful not to pinch them firmly with pliers. The pipes may get deformed.
- ◆ Provide a protective sheet or a steel plate so that the brazing flame cannot influence peripheries.
- ◆ Be careful so as not to burn the compressor terminals, the name plate, the outdoor heat exchanger fin.
- ◆ In case of difficulty with gas brazing machine
 1. Disconnect the brazed part where is easy to disconnect and restore.
 2. Cut pipes on the main unit with a tube cutter in order to make it easy to disconnect.

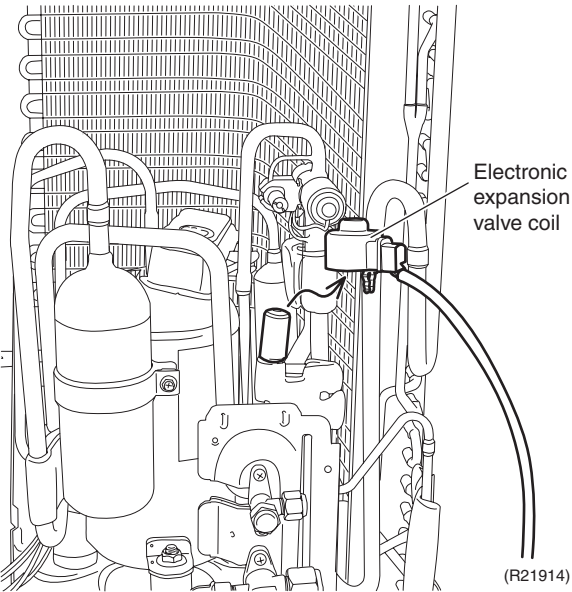
Step	Procedure	Points
1	Pull out the electronic expansion valve coil.	

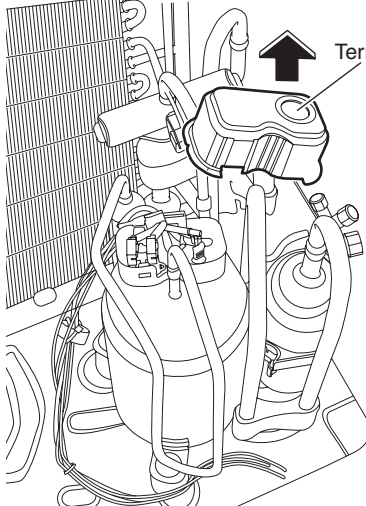
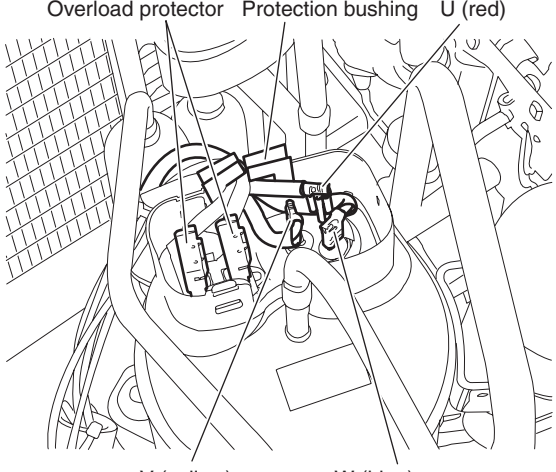
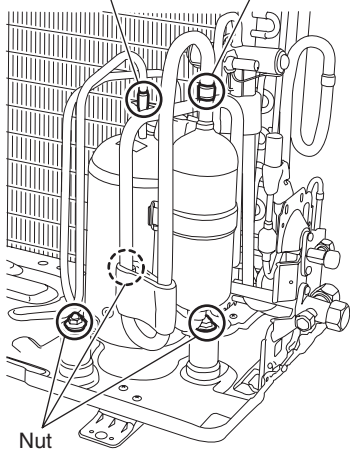
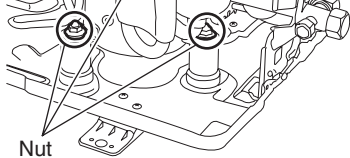
Step	Procedure	Procedure	Points
2	Remove the terminal cover.	 <p style="text-align: right;">Terminal cover</p> <p style="text-align: right;">(R21915)</p>	
3	Remove the protection bushing.	 <p style="text-align: center;">Overload protector Protection bushing U (red)</p> <p style="text-align: center;">V (yellow) W (blue)</p> <p style="text-align: right;">(R21916)</p>	
5	Heat up the brazed part of the discharge side pipe and disconnect it.	 <p style="text-align: center;">Brazed part of the discharge side pipe Brazed part of the suction side pipe</p>	
6	Heat up the brazed part of the suction side pipe and disconnect it.		
7	Remove the 3 nuts.		
8	Lift up the compressor and remove it.	 <p style="text-align: center;">Nut</p> <p style="text-align: right;">(R21917)</p>	

Revision History

Month / Year	Version	Revised contents
07 / 2015	Si001556E	First edition

Warning



- Daikin products are manufactured for export to numerous countries throughout the world. Prior to purchase, please confirm with your local authorised importer, distributor and/or retailer whether this product conforms to the applicable standards, and is suitable for use, in the region where the product will be used. This statement does not purport to exclude, restrict or modify the application of any local legislation.
- Ask a qualified installer or contractor to install this product. Do not try to install the product yourself. Improper installation can result in water or refrigerant leakage, electrical shock, fire or explosion.
- Use only those parts and accessories supplied or specified by Daikin. Ask a qualified installer or contractor to install those parts and accessories. Use of unauthorised parts and accessories or improper installation of parts and accessories can result in water or refrigerant leakage, electrical shock, fire or explosion.
- Read the user's manual carefully before using this product. The user's manual provides important safety instructions and warnings. Be sure to follow these instructions and warnings.

If you have any enquiries, please contact your local importer, distributor and/or retailer.

Cautions on product corrosion

1. Air conditioners should not be installed in areas where corrosive gases, such as acid gas or alkaline gas, are produced.
2. If the outdoor unit is to be installed close to the sea shore, direct exposure to the sea breeze should be avoided. If you need to install the outdoor unit close to the sea shore, contact your local distributor.

Dealer

DAIKIN INDUSTRIES, LTD.

Head Office:
Umeda Center Bldg., 2-4-12, Nakazaki-Nishi,
Kita-ku, Osaka, 530-8323 Japan

Tokyo Office:
JR Shinagawa East Bldg., 2-18-1, Konan,
Minato-ku, Tokyo, 108-0075 Japan

<http://www.daikin.com/products/ac/>

©All rights reserved