



Si001554EA

REMOVAL PROCEDURE



S E R V I C E M A N U A L

9000/12000 Btu/h Class

-  Outdoor Unit
-  Inverter
-  Pair Type

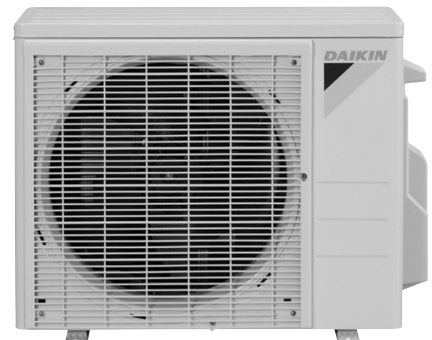

Service Manual Removal Procedure

Outdoor Unit

●Cooling Only

RK09NMVJU

RK12NMVJU

RKN09NMVJU

RKN12NMVJU

●Heat Pump

RX09NMVJU

RX12NMVJU

RXN09NMVJU

RXN12NMVJU

RXL09QMVJU

Table of Contents

| | |
|--|----|
| 1. Outer Panels | 2 |
| 2. Outdoor Fan / Fan Motor..... | 3 |
| 3. Electrical Box / PCB | 5 |
| 4. Thermistor ASSY | 10 |
| 5. Sound Blankets | 14 |
| 6. Reactor / Electronic Expansion Valve Coil / Partition Plate | 15 |
| 7. Four Way Valve..... | 17 |
| 8. Compressor..... | 19 |



Note:

- ♦ The illustrations may be slightly different depending on the model.
- ♦ The illustrations are for heat pump models as representative.

1. Outer Panels



Warning

- ♦ Be sure to wait for 10 minutes or more after turning off all power supplies before disassembling work.

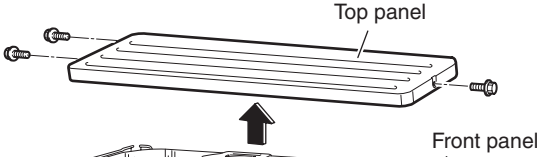
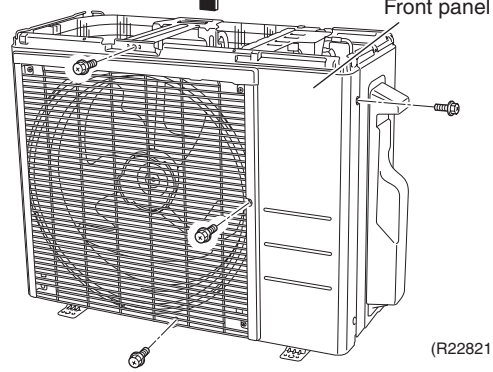
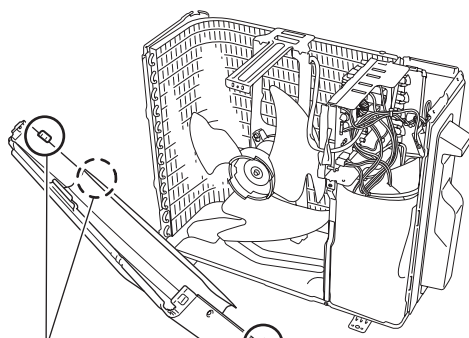
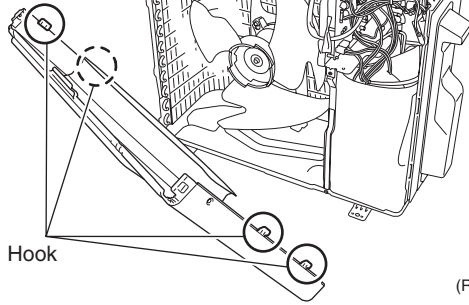
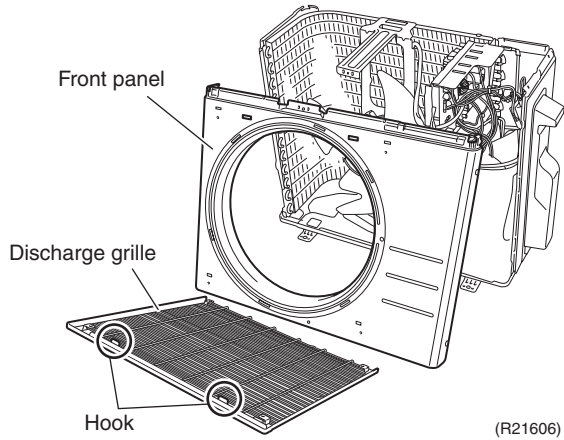
| Step | | Procedure | Points |
|------|--|---|--------|
| 1 | Remove the 3 screws and remove the top panel. |  <p>Top panel</p> <p>Front panel</p> <p>(R22821)</p> | |
| 2 | Remove the 4 screws of the front panel. |  <p>(R22821)</p> | |
| 3 | Unfasten the 2 left side hooks, and then the 2 right side hooks. |  <p>Hook</p> <p>(R21605)</p> | |
| 4 | Remove the front panel. |  <p>Hook</p> <p>(R21605)</p> | |
| 5 | Unfasten the 2 hooks on the top and remove the discharge grille. |  <p>Front panel</p> <p>Discharge grille</p> <p>Hook</p> <p>(R21606)</p> | |

2. Outdoor Fan / Fan Motor



Warning

- ◆ Be sure to wait for 10 minutes or more after turning off all power supplies before disassembling work.

| Step | Procedure | Points |
|------|--|--|
| 1 | Disconnect the connector [S71] and remove the filament tape. | [S71]: fan motor |
| 2 | Release the fan motor lead wire from the groove. | |
| 3 | Remove the nut of the outdoor fan. | ■ Nut size: M6 |
| 4 | Remove the outdoor fan. | ■ Align the ▼ mark of the outdoor fan with the D-cut section of the motor shaft when reassembling. |

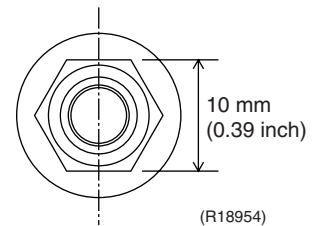
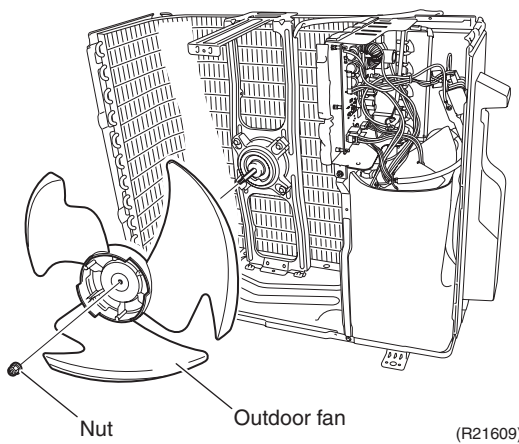
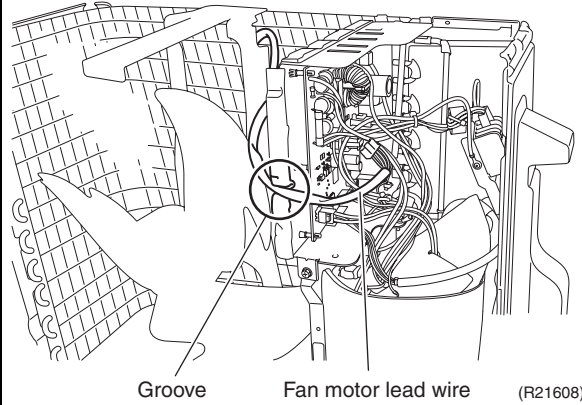
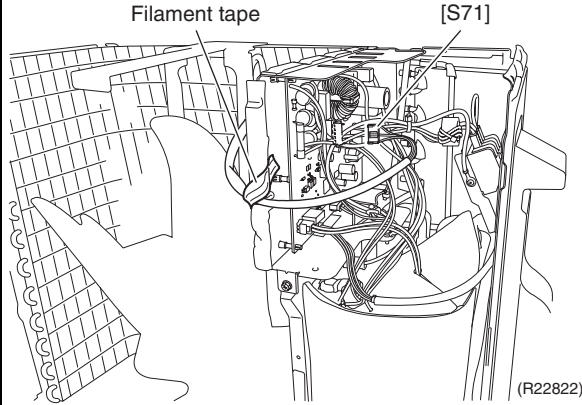

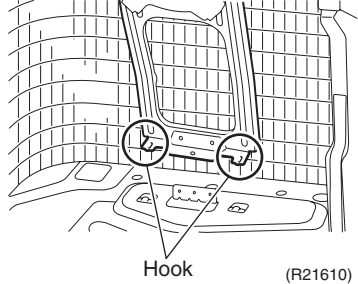
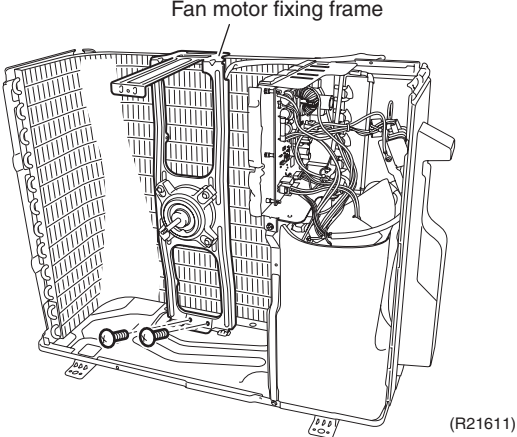
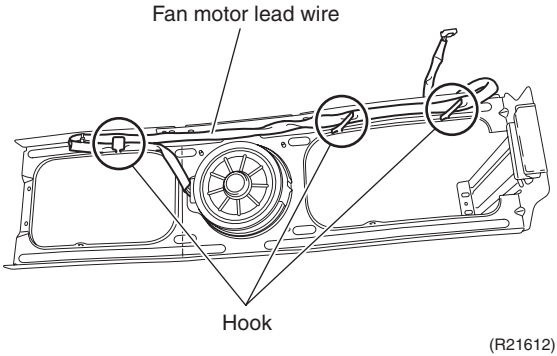
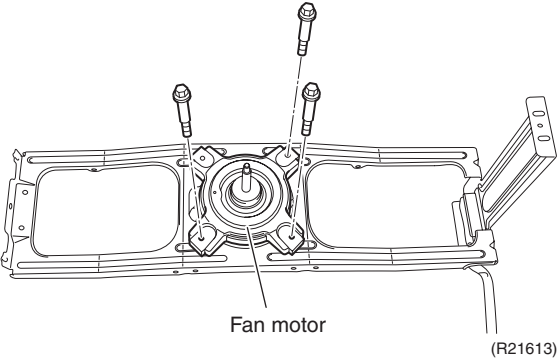
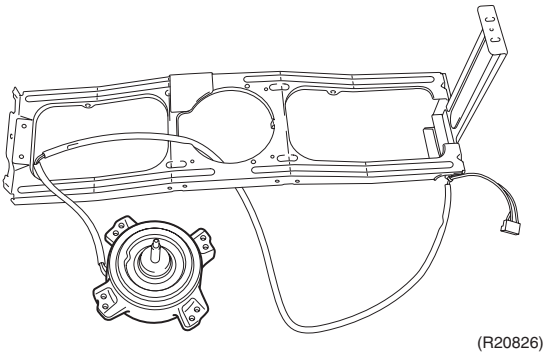
| Step | Procedure | Points |
|------|--|--|
| 5 | Remove the 2 screws and remove the fan motor fixing frame. | <ul style="list-style-type: none"> ■ When reassembling, fit the 2 lower hooks into the bottom frame. |
| 6 | Open the 3 hooks and release the fan motor lead wire. |  |
| 7 | Remove the 3 screws from the fan motor. |   |
| 8 | Remove the fan motor. |   |

3. Electrical Box / PCB



Warning

- ◆ Be sure to wait for 10 minutes or more after turning off all power supplies before disassembling work.

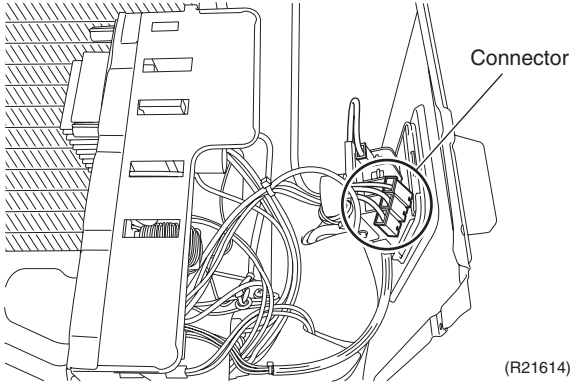
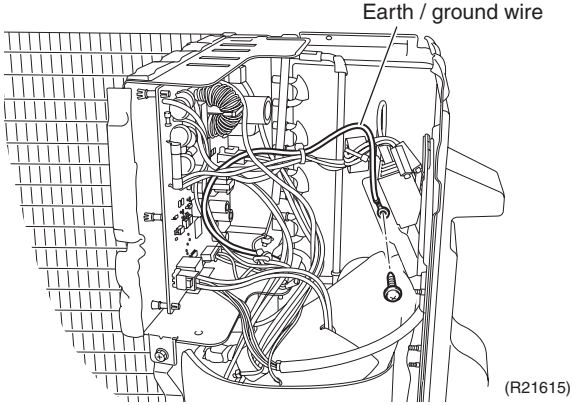
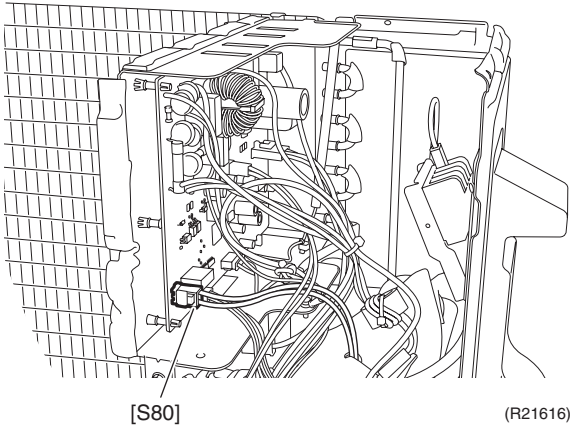
| Step | Procedure | Points |
|---|--|---|
| 1. Remove the electrical box. |  <p>(R21614)</p> | 1: black, front 2: white, front 3: red, front |
| 2. Remove the screw and detach the earth / ground wire. |  <p>(R21615)</p> | [S80]: four way valve coil |
| 3. Disconnect the connector [S80]. |  <p>[S80] (R21616)</p> | ■ Cooling only models have no harness for [S80]. |

| Step | Procedure | Points |
|------|---------------------------------|--|
| 4 | Disconnect the connector [S20]. | [S20]: electronic expansion valve coil |
| 5 | Disconnect the connector [S40]. | [S40]: overload protector |
| 6 | Disconnect the connector [S30]. | [S30]: compressor motor |

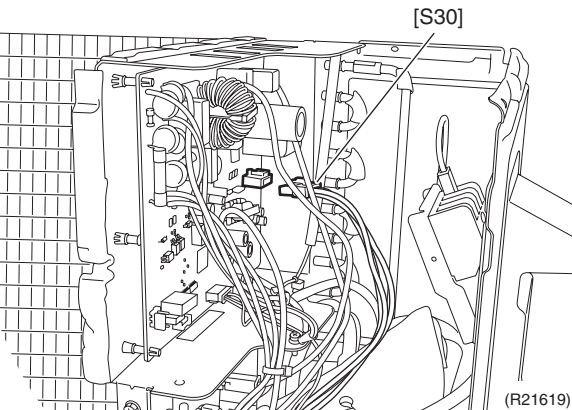
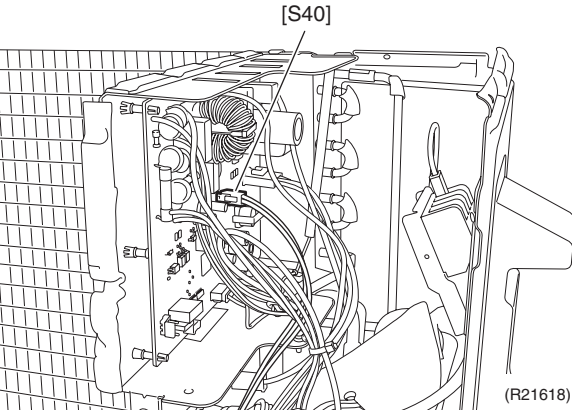
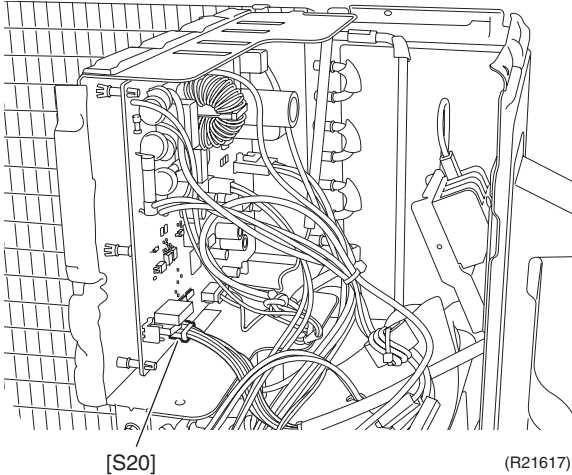

| Step | Procedure | Points |
|------|---|--|
| 7 | Disconnect the 2 connectors from the reactor. | <ul style="list-style-type: none"> ■ When reassembling, you can reconnect the 2 connectors for the reactor in either way regardless of the color. |
| 8 | Disconnect the connector [S90]. | [S90]: thermistors |
| 9 | Pull out the clamp from the bottom. | |

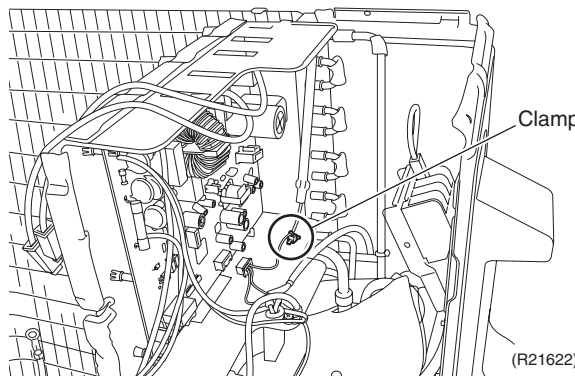
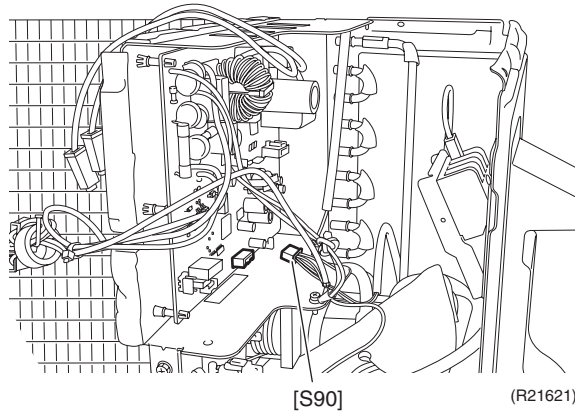
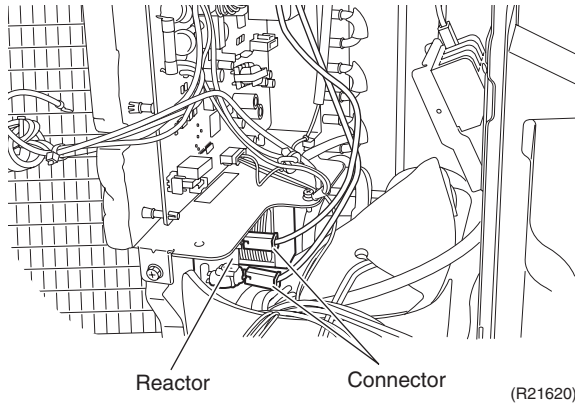

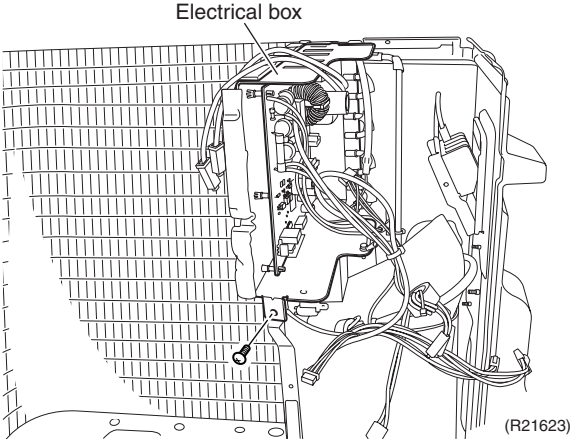
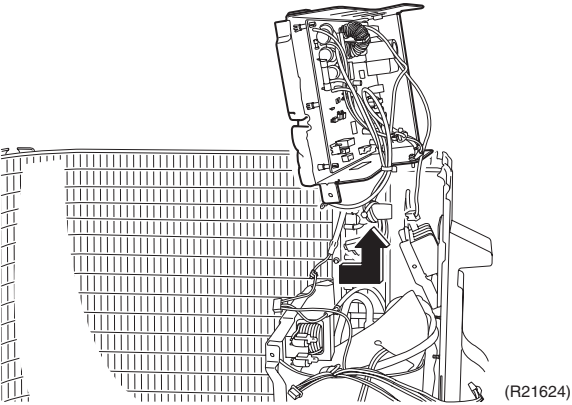
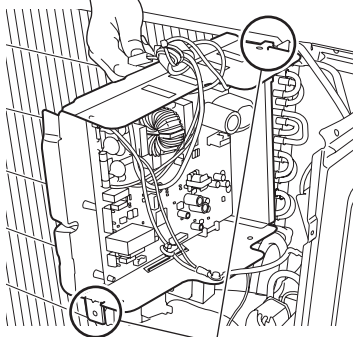
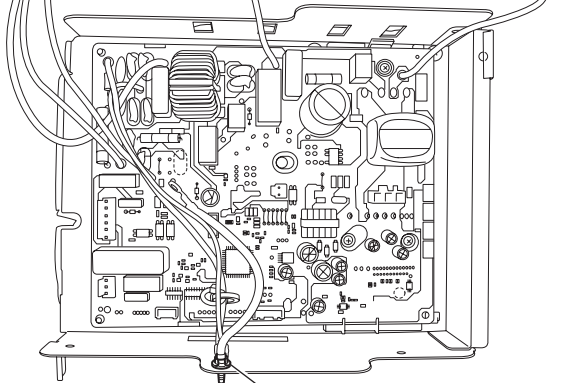
| Step | | Procedure | Points |
|--------------------|---|---|--|
| 10 | Remove the screw of the electrical box. |  <p style="text-align: center;">Electrical box</p> <p style="text-align: right;">(R21623)</p> | |
| 11 | Slide the electrical box to the right and lift up to remove it. |  <p style="text-align: right;">(R21624)</p> | <p>■ There are 2 hooks at the bottom and the top back of the electrical box.</p>  <p style="text-align: center;">Hook (R20839)</p> |
| 2. Remove the PCB. | | | |
| 1 | Remove earth / ground screw. |  <p style="text-align: center;">Earth / ground screw (R20840)</p> | |

| Step | Procedure | Points |
|------|--|--------|
| 2 | Remove the 3 screws of the PCB. | |
| 3 | Unfasten the 2 spacers and the 2 hooks from the PCB. | |
| 4 | Remove the PCB. | |

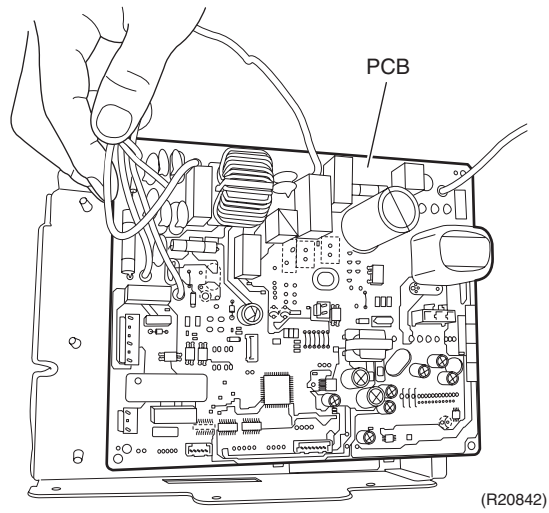
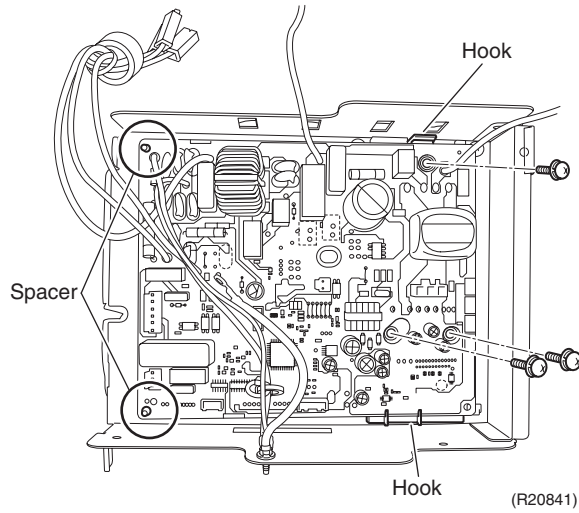

4. Thermistor ASSY



Warning

◆ Be sure to wait for 10 minutes or more after turning off all power supplies before disassembling work.

| Step | Procedure | Points |
|------|--|--|
| 1 | Remove the screw. | |
| 2 | Slide the stop valve cover downward and remove it. | ■ When reassembling, make sure to fit the 4 hooks. |
| 3 | Remove the 2 screws and lift up the protection plate to remove it. | ■ When reassembling, make sure to fit the 2 hooks. |

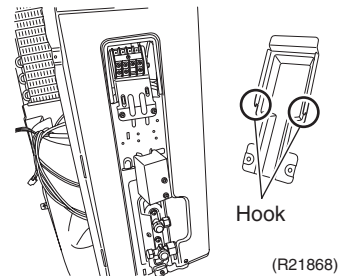
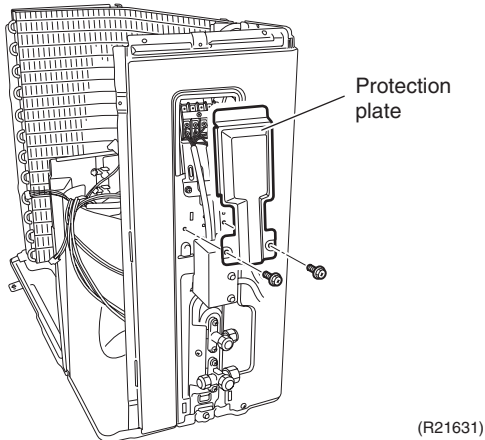
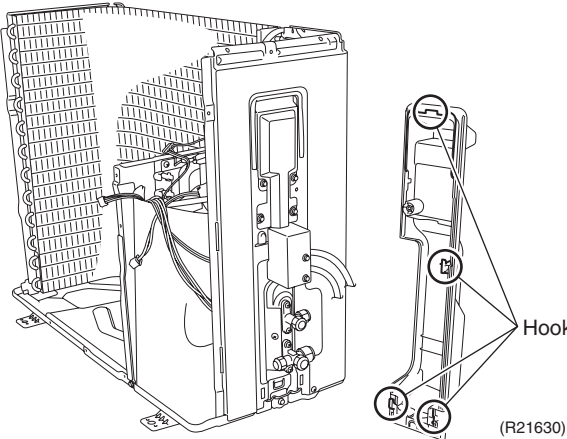
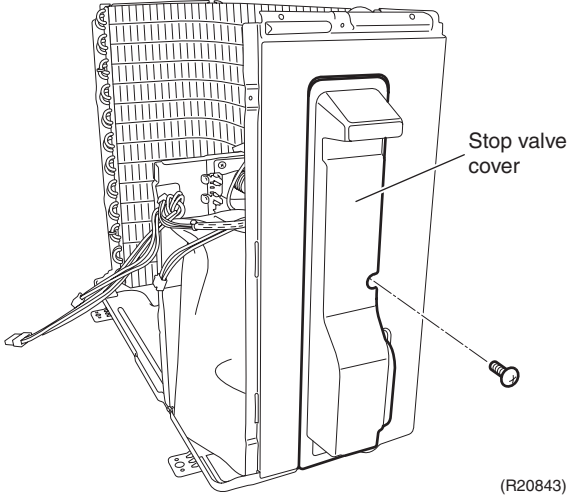

| Step | Procedure | Points |
|------|---|---|
| 4 | Remove the 2 screws and open the conduit mounting plate cover to the left, then remove it. | <ul style="list-style-type: none"> ■ The conduit mounting plate cover has a hook on the left and a projection on top. Be sure to catch them all when reassembling. |
| 5 | Remove the 7 screws on the terminal board and disconnect the connecting wire and the power supply wire. | |
| 6 | Remove the 3 screws of the right side panel. | |

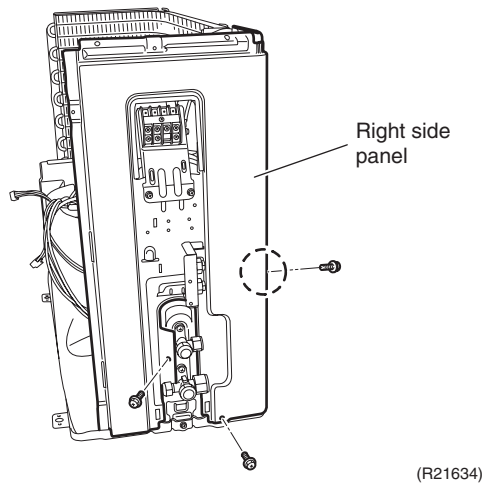
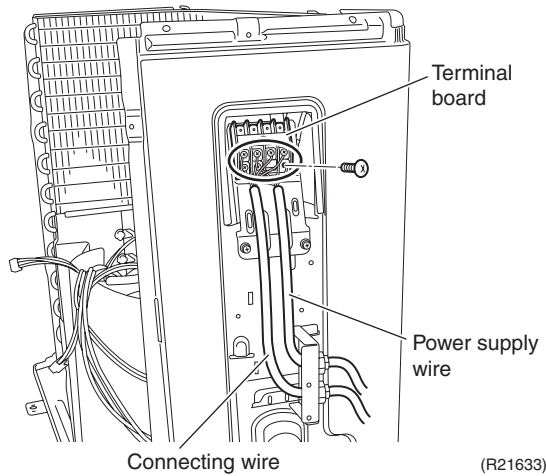
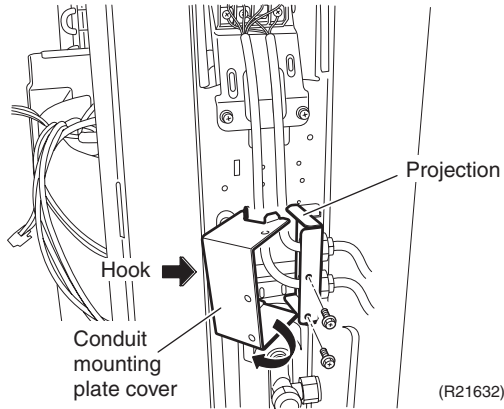

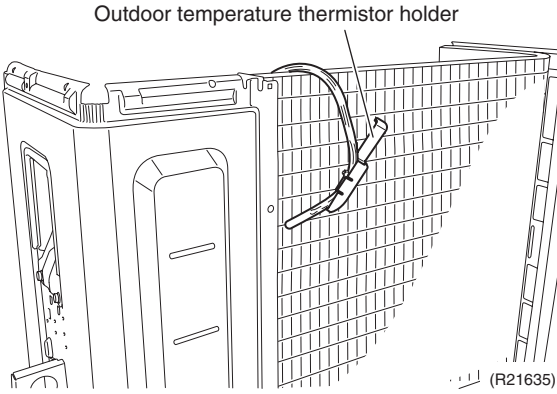
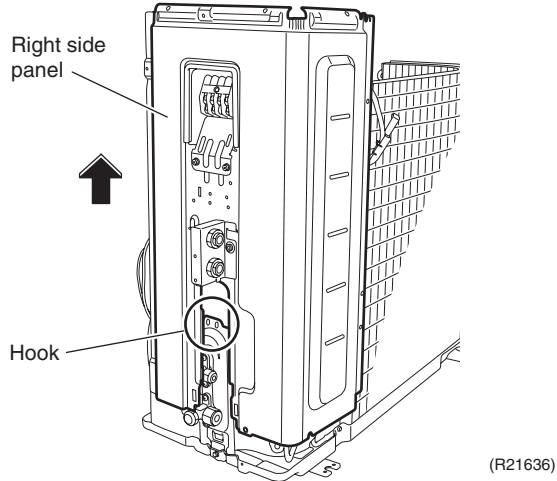
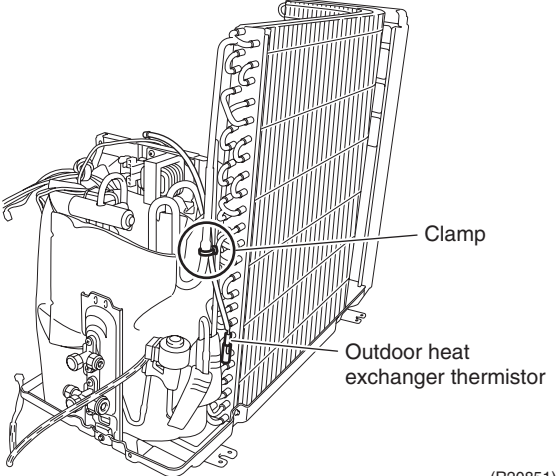
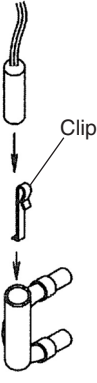
| Step | | Procedure | Points |
|------|---|--|---|
| 7 | Pull out the outdoor temperature thermistor holder. |  <p>Outdoor temperature thermistor holder</p> <p>(R21635)</p> | |
| 8 | Slide up the right side panel to unfasten the hook. |  <p>Right side panel</p> <p>Hook</p> <p>(R21636)</p> | |
| 9 | Remove the right side panel. | | |
| 10 | Cut the clamp. |  <p>Clamp</p> <p>Outdoor heat exchanger thermistor</p> <p>(R20851)</p> | <p>■ Be careful not to lose the clip for the thermistor.</p> |
| 11 | Pull out the outdoor heat exchanger thermistor. | |  <p>Clip</p> <p>(R20852)</p> |
| | | | <p>■ The location of the clamp is different depending on the model.</p> |

| Step | Procedure | Points |
|------|---|--|
| 12 | Pull out the discharge pipe temperature thermistor and remove the thermistor ASSY. | <ul style="list-style-type: none"> ■ Be careful not to lose the fixture for the thermistor. |
| | <p>Discharge pipe temperature thermistor</p> <p>Thermistor ASSY</p> <p>(R20853)</p> <p>(R20855)</p> | <p>Fixture</p> <p>(R20854)</p> |

5. Sound Blankets



Warning

◆ Be sure to wait for 10 minutes or more after turning off all power supplies before disassembling work.

| Step | Procedure | Points |
|------|---|--|
| 1 | Remove the sound blanket (top). | <ul style="list-style-type: none"> ■ The design of sound blanket varies depending on the model. ■ Since the piping ports on the sound blanket are torn easily, remove the blanket carefully. |
| 2 | Detach the fastener and pull out the sound blanket (outer). | (R20857) |
| 3 | Pull out the sound blanket (inner). | (R20858) |

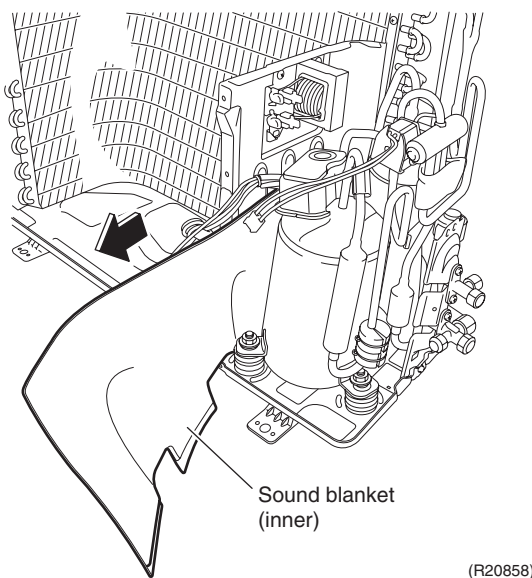
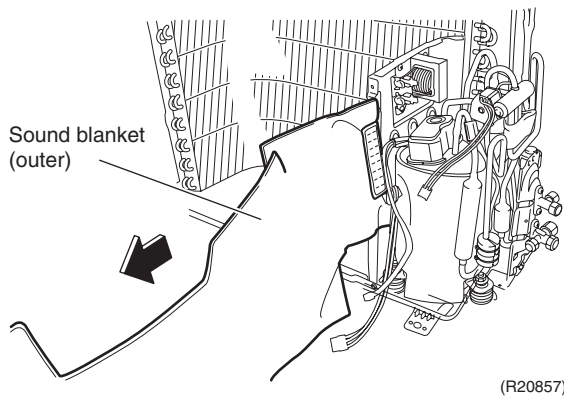
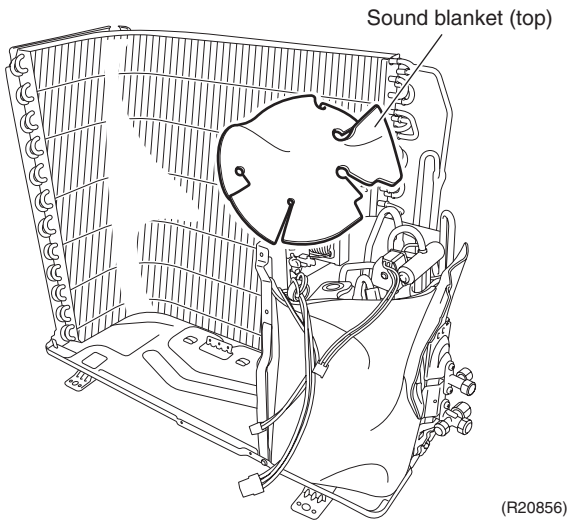

6. Reactor / Electronic Expansion Valve Coil / Partition Plate



Warning

- ◆ Be sure to wait for 10 minutes or more after turning off all power supplies before disassembling work.

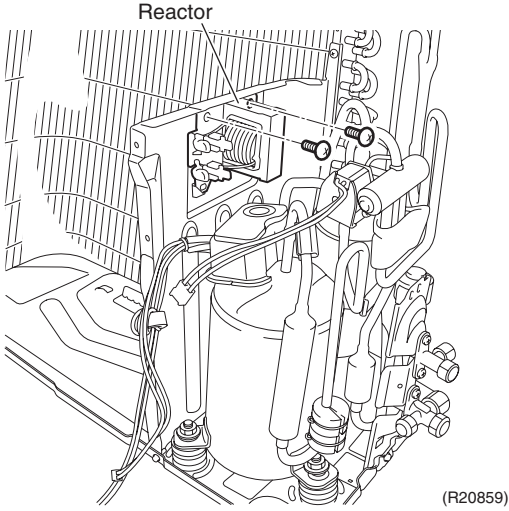
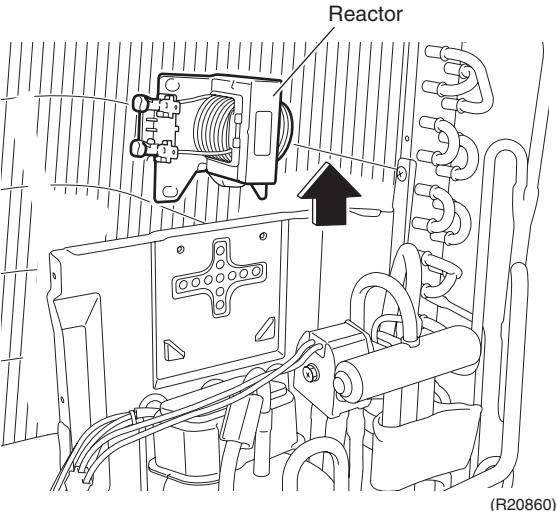
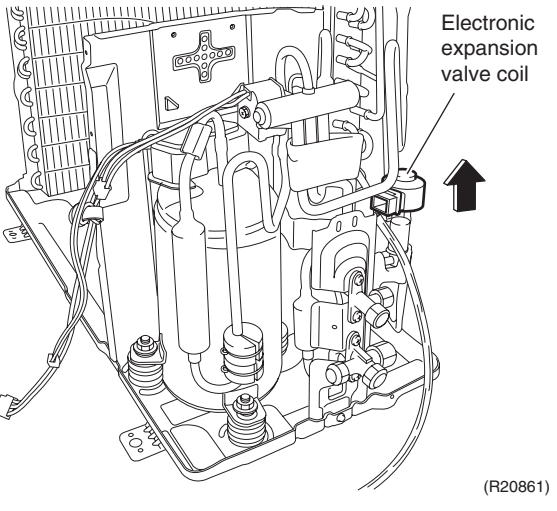
| Step | Procedure | Points |
|------|--|--------|
| 1 | Remove the 2 screws of the reactor.  | |
| 2 | Slide upward the reactor and remove it.  | |
| 3 | Pull out the electronic expansion valve coil.  | |

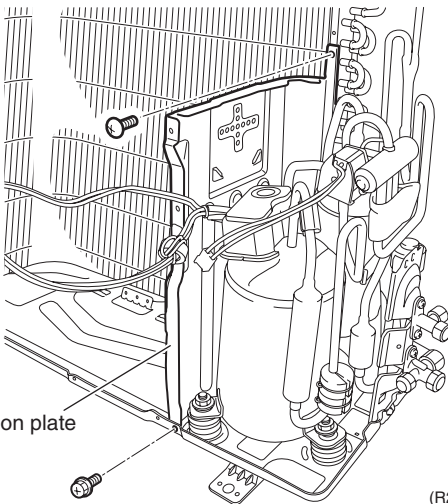
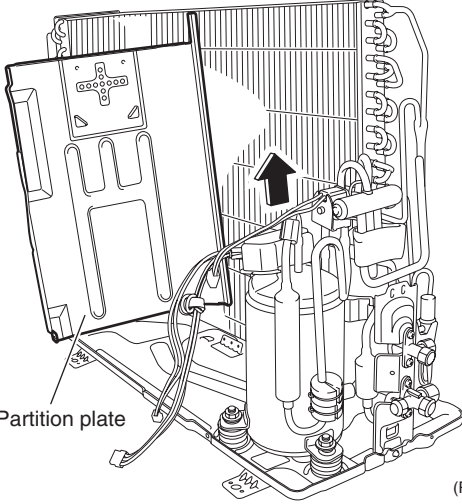
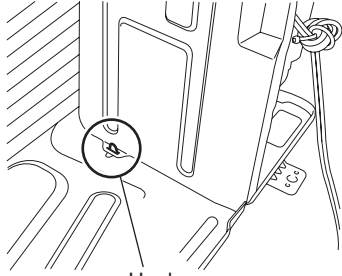
| Step | Procedure | Points |
|------|--|--|
| 4 | Remove the 2 screws of the partition plate. | |
| |  <p>Diagram (R20862) shows a side view of the reactor assembly. A partition plate is positioned in front of the internal components. Two screws are shown being removed from the top edge of the partition plate. A label 'Partition plate' points to the plate, and a screw is shown being removed. Reference code (R20862) is at the bottom right.</p> | |
| 5 | Lift up the partition plate and remove it. | <p>■ When reassembling, fit the hook on the bottom frame.</p> |
| |  <p>Diagram (R20863) shows the partition plate being lifted away from the reactor assembly. An upward-pointing arrow indicates the direction of movement. A label 'Partition plate' points to the plate. Reference code (R20863) is at the bottom right.</p> |  <p>Diagram (R20864) is a close-up view of the bottom frame of the reactor. A hook is shown being fitted into a slot. A label 'Hook' points to the hook. Reference code (R20864) is at the bottom right.</p> |

7. Four Way Valve



Warning

- ◆ Be sure to wait for 10 minutes or more after turning off all power supplies before disassembling work.
- ◆ Be careful not to get yourself burnt with the pipes and other parts that are heated by the gas brazing machine.
- ◆ If the refrigerant gas leaks during work, ventilate the room. (If the refrigerant gas is exposed to flames, toxic gas may be generated.)



Caution

- ◆ From the viewpoint of global environment protection, do not discharge the refrigerant gas in the atmosphere. Make sure to collect all the refrigerant gas.
- ◆ Cautions for restoration
 1. Restore the piping by non-oxidation brazing.
 2. It is required to prevent the carbonization of the oil inside the four way valve and the deterioration of the gaskets affected by heat. (Keep below 120°C (248°F).) For the sake of this, wrap the four way valve with wet cloth and provide water so that the cloth does not dry.



Note

- ◆ Before working, make sure that the refrigerant gas is empty in the circuit.
- ◆ Be sure to apply nitrogen replacement when heating up the brazed part.
- ◆ Do not use a metal saw for cutting pipes by all means because the sawdust comes into the circuit.
- ◆ When withdrawing the pipes, be careful not to pinch them firmly with pliers. The pipes may get deformed.
- ◆ Provide a protective sheet or a steel plate so that the brazing flame cannot influence peripheries.
- ◆ Be careful so as not to burn the compressor terminals, the name plate, the outdoor heat exchanger fin.
- ◆ In case of difficulty with gas brazing machine
 1. Disconnect the brazed part where is easy to disconnect and restore.
 2. Cut pipes on the main unit with a tube cutter in order to make it easy to disconnect.

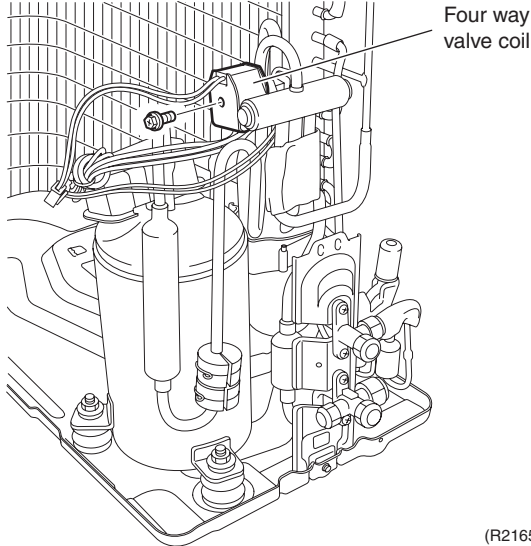
| Step | Procedure | Points |
|------|--|--|
| 1 | Remove the screw and remove the four way valve coil.  <p style="text-align: right;">(R21650)</p> | <ul style="list-style-type: none"> ■ Cooling only models have no four way valve coil. |

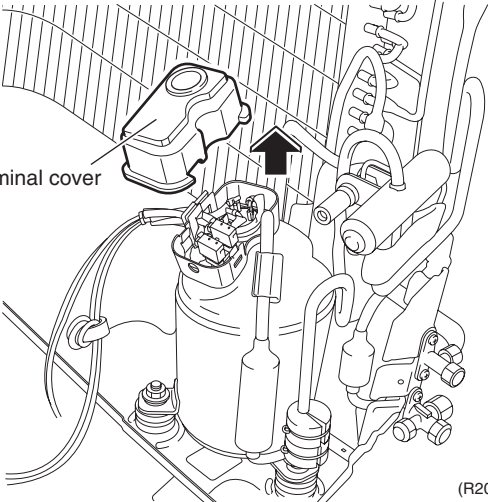
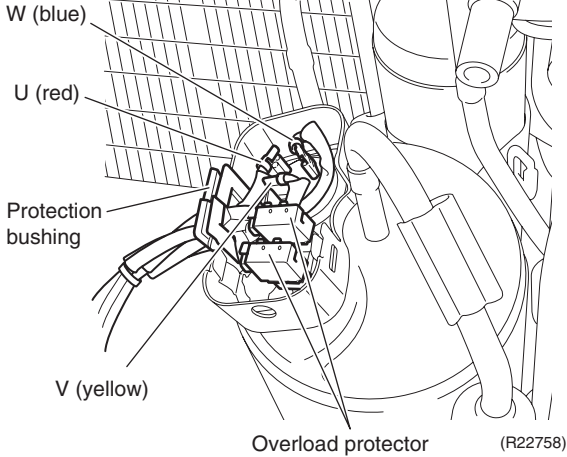
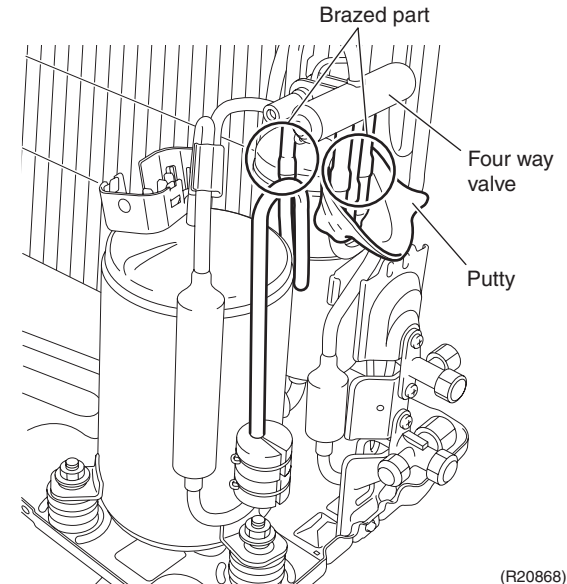
| Step | Procedure | Points |
|------|--|--------|
| 2 | Remove the terminal cover. | |
| |  <p>Terminal cover</p> <p>(R20866)</p> | |
| 3 | Remove the protection bushing. | |
| 4 | Disconnect the compressor lead wires and the overload protector. | |
| |  <p>W (blue)</p> <p>U (red)</p> <p>Protection bushing</p> <p>V (yellow)</p> <p>Overload protector</p> <p>(R22758)</p> | |
| 5 | Remove the sheet of putty. | |
| 6 | Heat up and disconnect the every brazed part of the four way valve. | |
| 7 | Remove the four way valve. | |
| |  <p>Brazed part</p> <p>Four way valve</p> <p>Putty</p> <p>(R20868)</p> | |

8. Compressor



Warning

- ◆ Be sure to wait for 10 minutes or more after turning off all power supplies before disassembling work.
- ◆ Be careful not to get yourself burnt with the pipes and other parts that are heated by the gas brazing machine.
- ◆ If the refrigerant gas leaks during work, ventilate the room. (If the refrigerant gas is exposed to flames, toxic gas may be generated.)
- ◆ Since it may happen that the refrigerant oil in the compressor catches fire, prepare wet cloth so as to extinguish fire immediately.



Caution

- ◆ From the viewpoint of global environment protection, do not discharge the refrigerant gas in the atmosphere. Make sure to collect all the refrigerant gas.
- ◆ Restore the piping by non-oxidation brazing.



Note

- ◆ Before working, make sure that the refrigerant gas is empty in the circuit.
- ◆ Be sure to apply nitrogen replacement when heating up the brazed part.
- ◆ Do not use a metal saw for cutting pipes by all means because the sawdust comes into the circuit.
- ◆ When withdrawing the pipes, be careful not to pinch them firmly with pliers. The pipes may get deformed.
- ◆ Provide a protective sheet or a steel plate so that the brazing flame cannot influence peripheries.
- ◆ Be careful so as not to burn the compressor terminals, the name plate, the outdoor heat exchanger fin.
- ◆ In case of difficulty with gas brazing machine
 1. Disconnect the brazed part where is easy to disconnect and restore.
 2. Cut pipes on the main unit with a tube cutter in order to make it easy to disconnect.

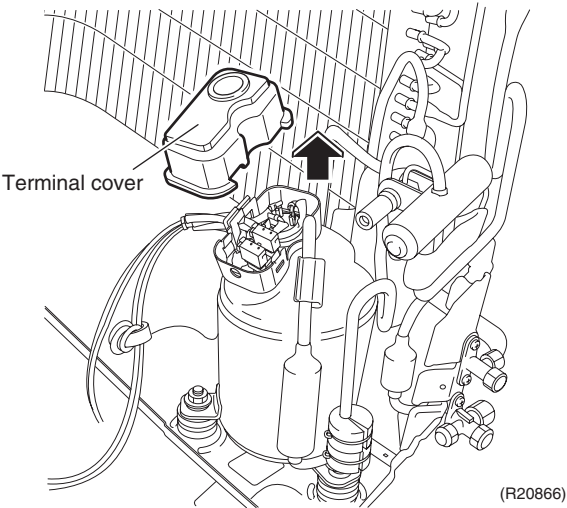
| Step | Procedure | Procedure | Points |
|------|----------------------------|--|--------|
| 1 | Remove the terminal cover. |  | |

| Step | Procedure | Points |
|------|---|--------|
| 2 | Remove the protection bushing. | |
| 3 | Disconnect the compressor lead wires and the overload protector. | |
| 4 | Heat up the brazed part of the discharge side pipe and disconnect it. | |
| 5 | Heat up the brazed part of the suction side pipe and disconnect it. | |
| 6 | Remove the 3 nuts of the compressor. | |
| 7 | Lift up the compressor and remove it. | |

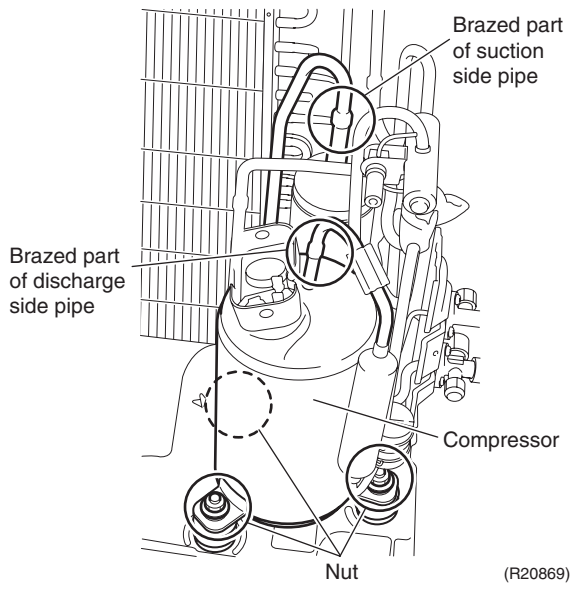
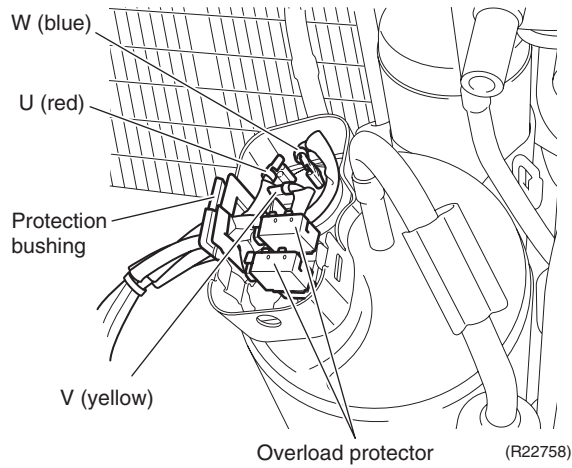

Revision History

| Month / Year | Version | Revised contents |
|--------------|------------|----------------------------|
| 06 / 2015 | Si001554E | First edition |
| 01 / 2016 | Si001554EA | Model addition: RXL09QMVJU |

Warning



- Daikin products are manufactured for export to numerous countries throughout the world. Prior to purchase, please confirm with your local authorised importer, distributor and/or retailer whether this product conforms to the applicable standards, and is suitable for use, in the region where the product will be used. This statement does not purport to exclude, restrict or modify the application of any local legislation.
- Ask a qualified installer or contractor to install this product. Do not try to install the product yourself. Improper installation can result in water or refrigerant leakage, electrical shock, fire or explosion.
- Use only those parts and accessories supplied or specified by Daikin. Ask a qualified installer or contractor to install those parts and accessories. Use of unauthorised parts and accessories or improper installation of parts and accessories can result in water or refrigerant leakage, electrical shock, fire or explosion.
- Read the user's manual carefully before using this product. The user's manual provides important safety instructions and warnings. Be sure to follow these instructions and warnings.

If you have any enquiries, please contact your local importer, distributor and/or retailer.

Cautions on product corrosion

1. Air conditioners should not be installed in areas where corrosive gases, such as acid gas or alkaline gas, are produced.
2. If the outdoor unit is to be installed close to the sea shore, direct exposure to the sea breeze should be avoided. If you need to install the outdoor unit close to the sea shore, contact your local distributor.

Dealer

DAIKIN INDUSTRIES, LTD.

Head Office:
Umeda Center Bldg., 2-4-12, Nakazaki-Nishi,
Kita-ku, Osaka, 530-8323 Japan

Tokyo Office:
JR Shinagawa East Bldg., 2-18-1, Konan,
Minato-ku, Tokyo, 108-0075 Japan

<http://www.daikin.com/products/ac/>

©All rights reserved