

# REMOVAL PROCEDURE



## S E R V I C E M A N U A L

### 2.5/3.5 kW Class

-  Outdoor Unit
-  Inverter
-  Pair Type

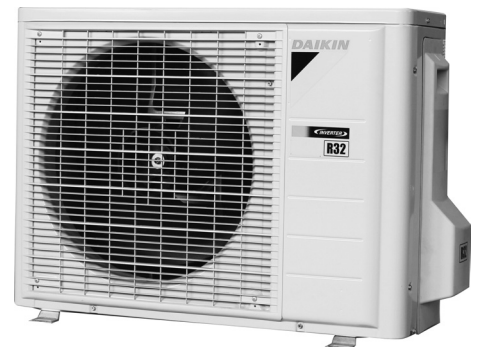

# **Service Manual Removal Procedure**

## **Outdoor Unit**

### **●Cooling Only**

**RKH35QRV16**

**RKH35RRV16**

**RKP25PRV16**

**RKP35PRV16**

**RKP25QRV16**

**RKP35QRV16**

**RKPA25QRV16**

**RKPA35QRV16**

**RKPD25QRV16**

**RKPD35QRV16**

# Table of Contents

1. Outer Panels .....	2
2. Fan Motor .....	4
3. Electrical Box .....	6
4. Thermistor ASSY .....	8
5. PCB.....	9
6. Reactor / Partition Plate .....	11
7. Sound Blankets.....	12
8. Capillary Tube .....	13
9. Compressor.....	15



**Note:** ♦ The illustrations may be slightly different depending on the model.

# 1. Outer Panels



**Warning**

◆ Be sure to wait for 10 minutes or more after turning off all power supplies before disassembling work.

Step	Procedure	Points
1	Remove the screw of the stop valve cover.	■ The stop valve cover is united with the shield plate.
2	Pull down the stop valve cover and remove it.	■ When reassembling, make sure to fit the 5 hooks.
3	Remove the 2 screws, and then the top panel.	■ The discharge grille has 4 hooks.
4	Remove the 4 screws, and then the discharge grille.	■ The front panel has 4 hooks.
5	Remove the 7 screws, and then the front panel.	

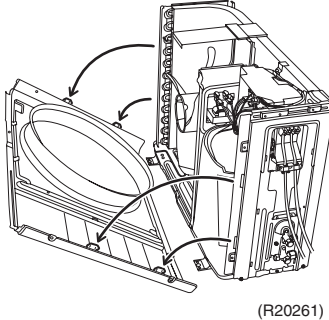
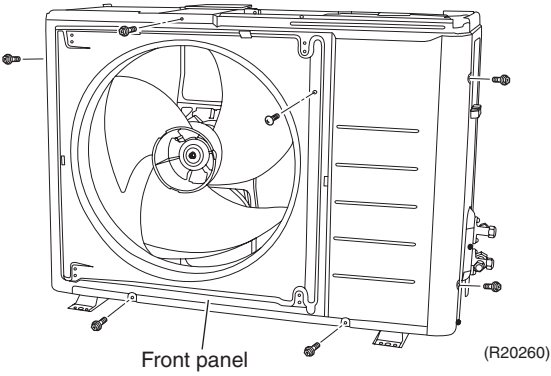
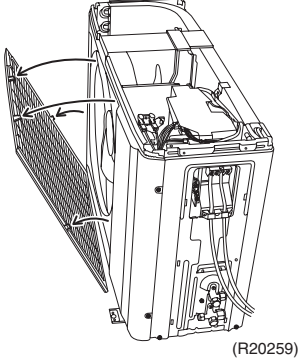
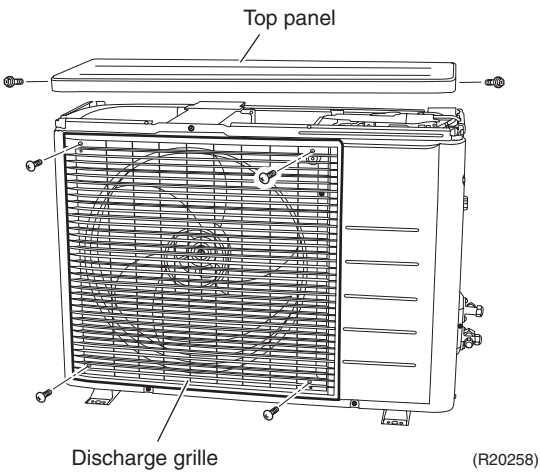
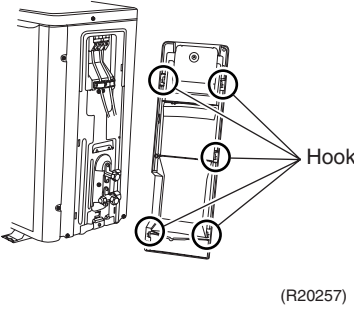
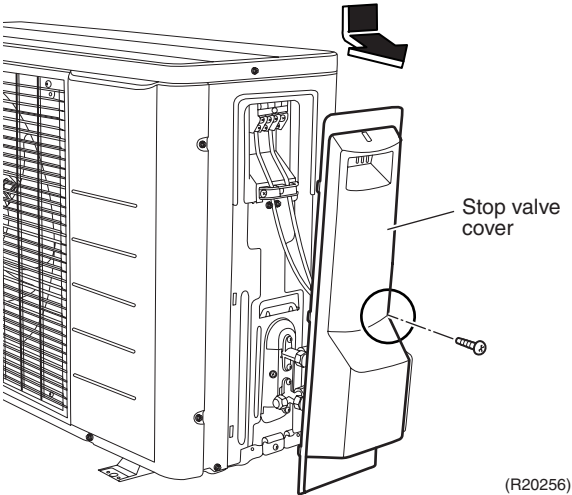

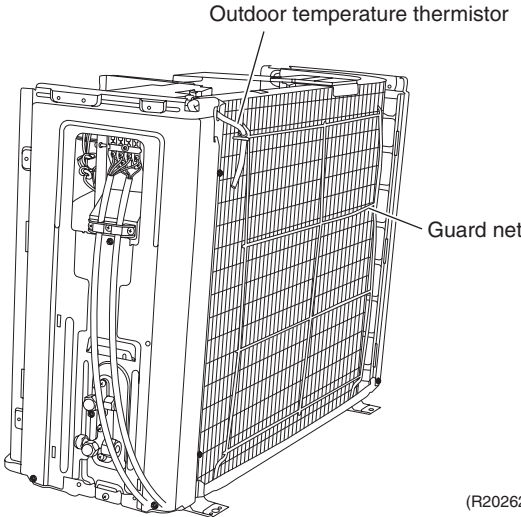
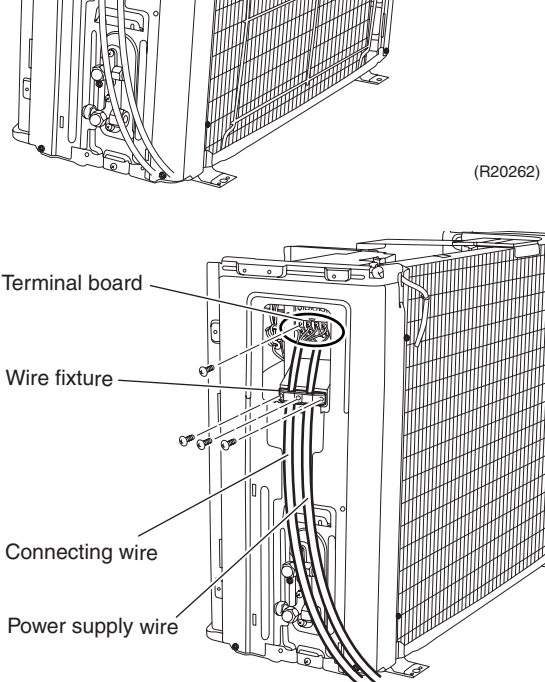
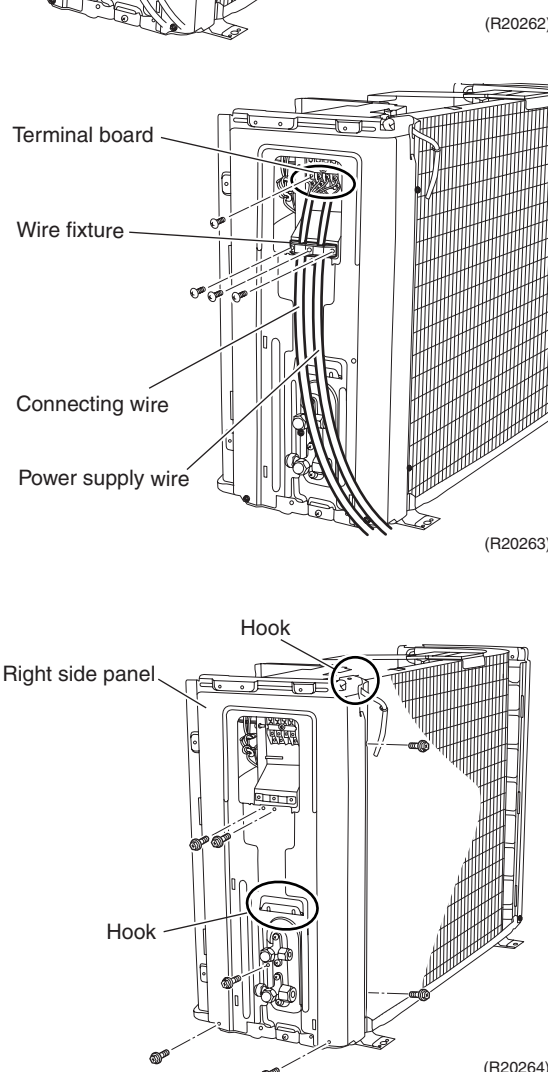
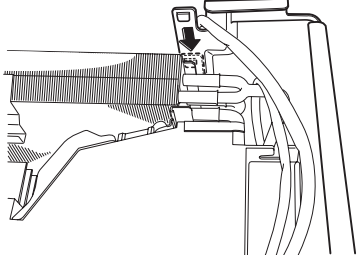
Step	Procedure	Procedure	Points
6	Release the outdoor temperature thermistor.	 <p>Outdoor temperature thermistor</p> <p>Guard net</p> <p>(R20262)</p>	<ul style="list-style-type: none"> <li>Be careful not to cut your finger on the fins of the outdoor heat exchanger.</li> </ul>
7	Lift up the guard net and remove it.		
8	Remove the 3 screws, and then the wire fixture.		
9	Remove the 7 screws on the terminal board and disconnect both the connecting wire and the power supply wire.	 <p>Terminal board</p> <p>Wire fixture</p> <p>Connecting wire</p> <p>Power supply wire</p> <p>(R20263)</p>	
10	Remove the 7 screws on the right side panel.		
11	Lift up the right side panel and remove it.	 <p>Hook</p> <p>Right side panel</p> <p>Hook</p> <p>(R20264)</p>	<ul style="list-style-type: none"> <li>When reassembling, make sure to fit the hooks on the right and rear side.</li> </ul>
		 <p>(R22578)</p>	

## 2. Fan Motor



**Warning**

◆ Be sure to wait for 10 minutes or more after turning off all power supplies before disassembling work.

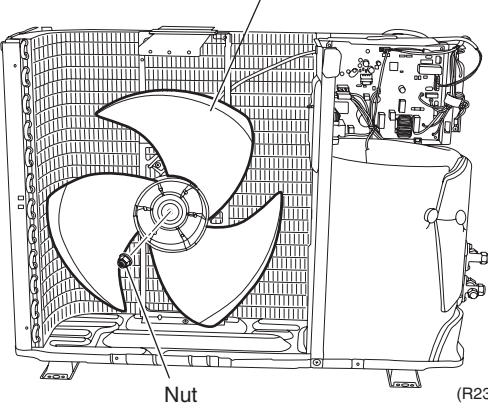
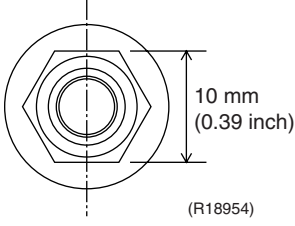
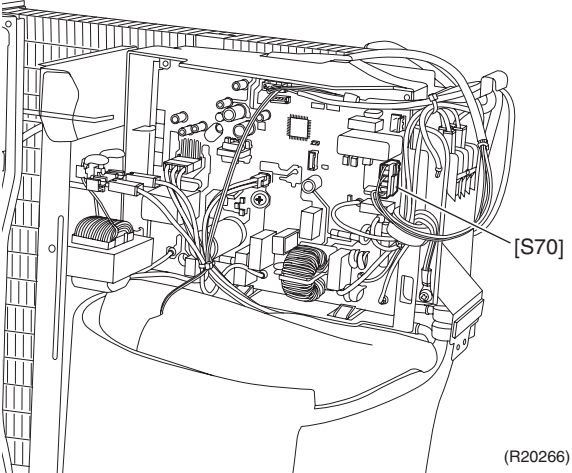
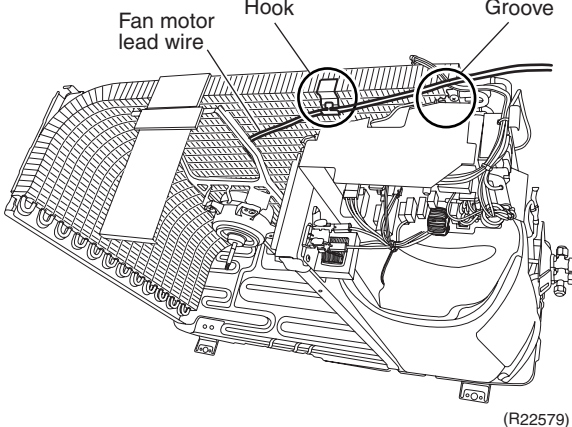
Step	Procedure	Points
<p>1 Remove the nut of the outdoor fan.</p> <p>2 Remove the outdoor fan.</p>		<ul style="list-style-type: none"> <li>■ You can remove the fan without removing the right side panel.</li> <li>■ Nut size: M6</li> </ul>  <ul style="list-style-type: none"> <li>■ When reassembling, align the ▼ mark of the outdoor fan with the D-cut section of the motor shaft.</li> </ul>
<p>3 Disconnect the connector [S70].</p>		<p>[S70]: fan motor</p>
<p>4 Release the fan motor lead wire from the groove and the hook.</p>		<ul style="list-style-type: none"> <li>■ Some models do not have the hook.</li> </ul>

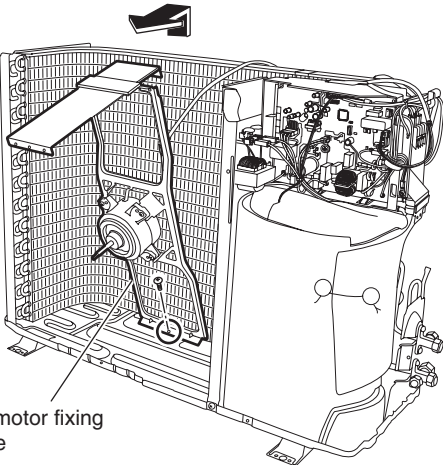
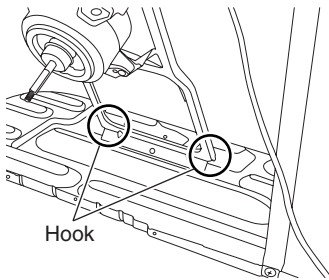
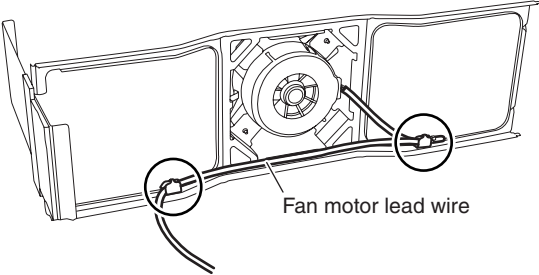
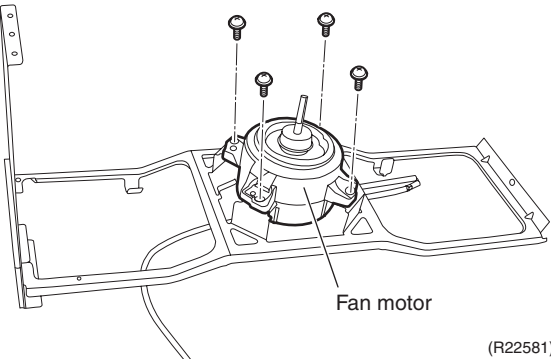
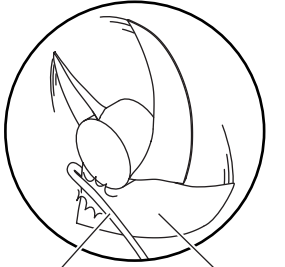
Step	Procedure	Points
5	Remove the screw and, then the fan motor fixing frame.	<ul style="list-style-type: none"> <li>When reassembling, fit the 2 lower hooks into the bottom frame.</li> </ul>
	 <p style="text-align: right;">(R20268)</p>	 <p style="text-align: right;">(R20269)</p>
6	Unfasten the 2 hooks and release the fan motor lead wire.	
	 <p style="text-align: right;">(R22580)</p>	
7	Remove the 4 screws, and then the fan motor.	<ul style="list-style-type: none"> <li>When reassembling, put the fan motor lead wire through the back of the fan motor to avoid any entanglement with the outdoor fan.</li> </ul>
	 <p style="text-align: right;">(R22581)</p>	 <p style="text-align: right;">(R3249)</p>



# 3. Electrical Box



**Warning**

♦ Be sure to wait for 10 minutes or more after turning off all power supplies before disassembling work.

Step	Procedure	Points
1	Cut the clamp.	
2	Disconnect the connector [S30].	[S30]: compressor
3	Disconnect the connector [S40].	[S40]: overload protector

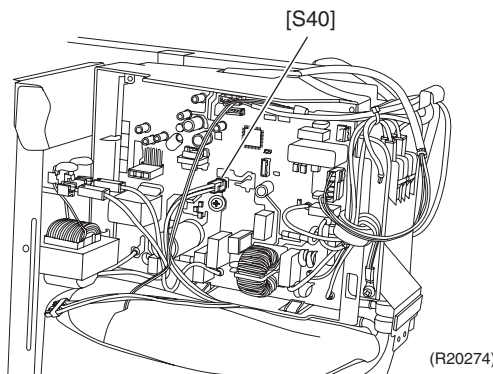
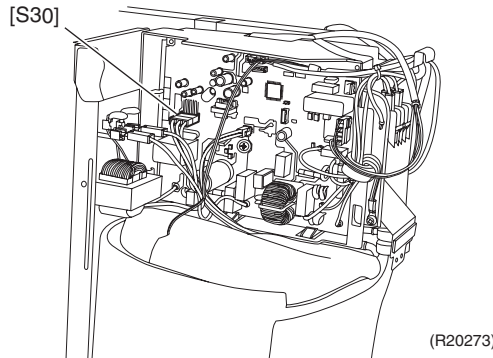
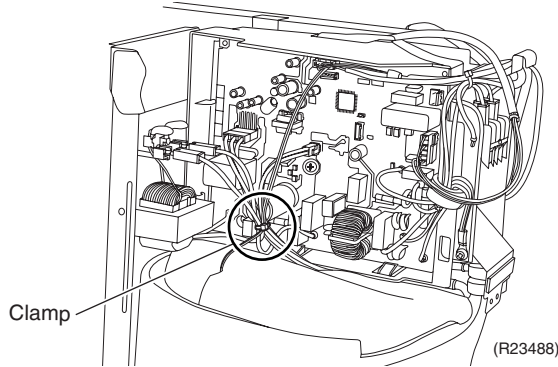



Step	Procedure	Points
4	Disconnect the 2 connectors for the reactor.	
5	Disconnect the connector [S90].	[S90]: thermistors
6	Cut the clamp.	
7	Lift up and remove the electrical box.	

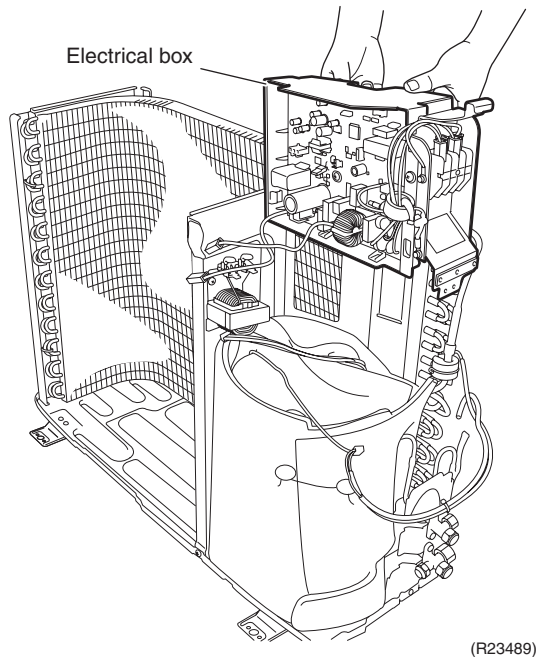
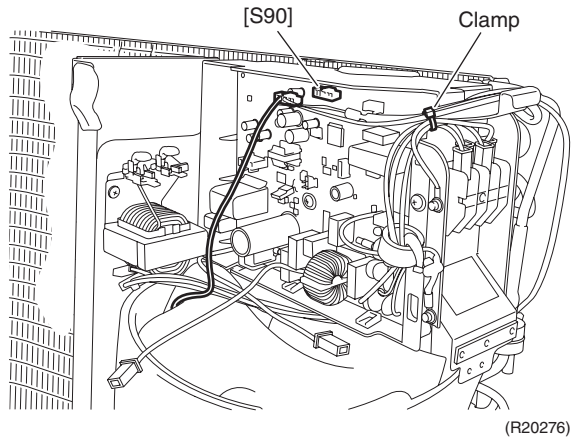
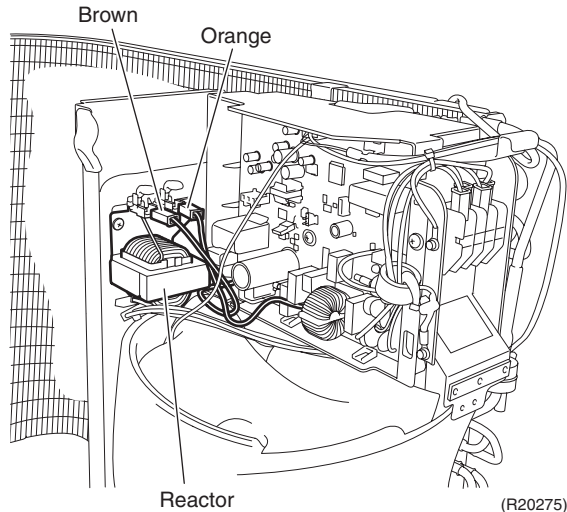

# 4. Thermistor ASSY



**Warning**

◆ Be sure to wait for 10 minutes or more after turning off all power supplies before disassembling work.

Step	Procedure	Points
1	Release the discharge pipe thermistor.	<ul style="list-style-type: none"> <li>■ Be careful not to lose the fixture for the thermistor.</li> </ul>
2	Cut the clamp.	<ul style="list-style-type: none"> <li>■ The positions of the clamp and outdoor heat exchanger thermistor vary depending on the model.</li> </ul>
3	Pull out the outdoor heat exchanger thermistor.	<ul style="list-style-type: none"> <li>■ Be careful not to lose the clip for the thermistor.</li> </ul>
4	Remove the thermistor ASSY.	

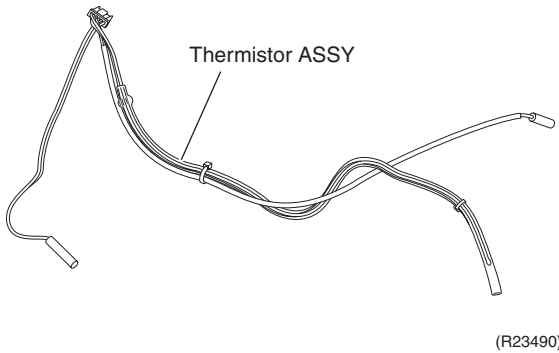
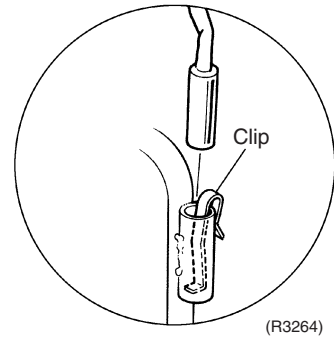
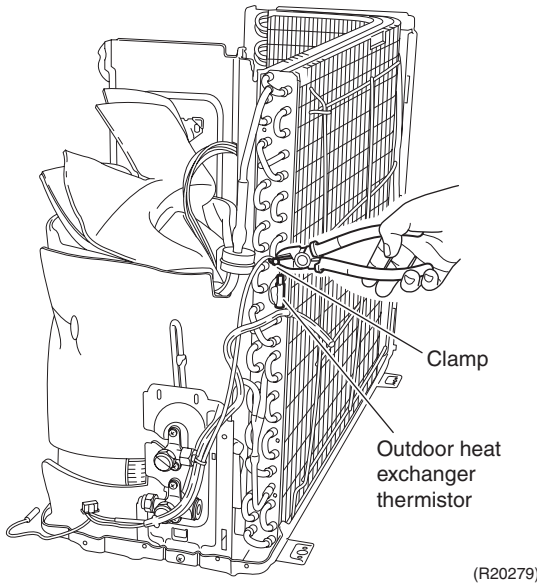
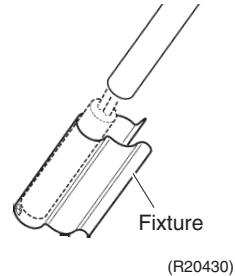
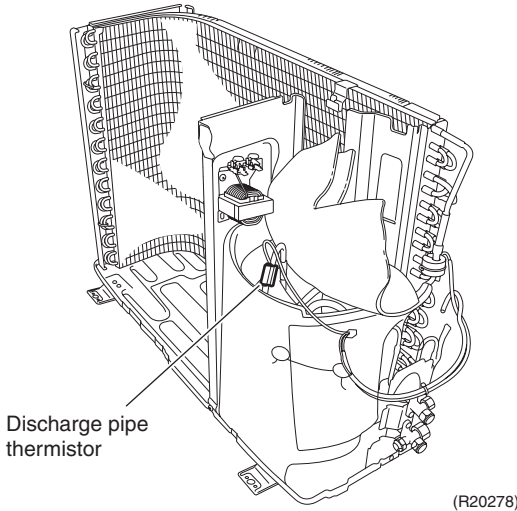

# 5. PCB



**Warning**

◆ **Be sure to wait for 10 minutes or more after turning off all power supplies before disassembling work.**

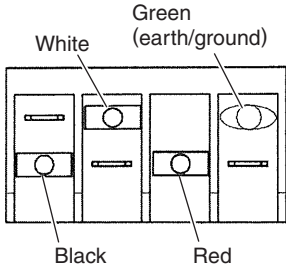
Step	Procedure	Points
1	Remove the screw on the terminal board.	<ul style="list-style-type: none"> <li>■ You can remove the main PCB when you disconnect the lead wires on the terminal board without removing the terminal board.</li> </ul>
2	Remove the earth/ground screw (lower).	
3	Disconnect all the terminals from the terminal board.	
4	Cut the clamp.	

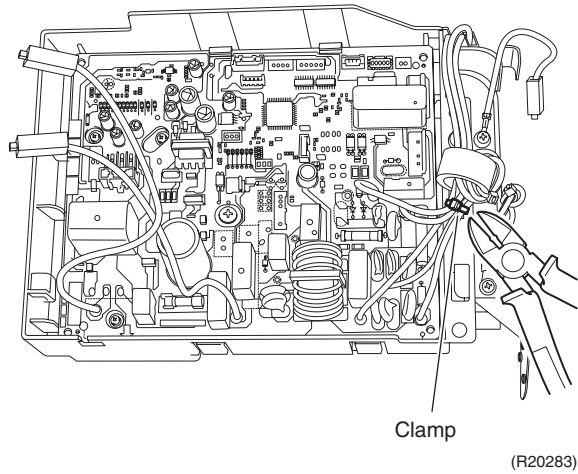
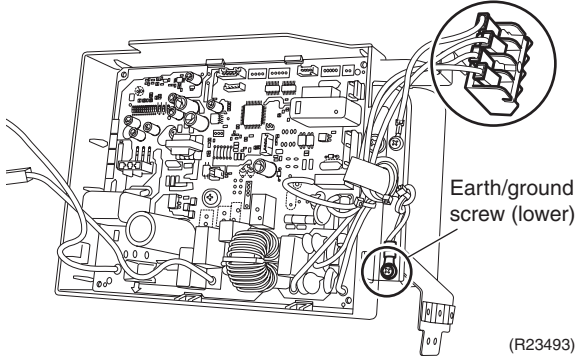
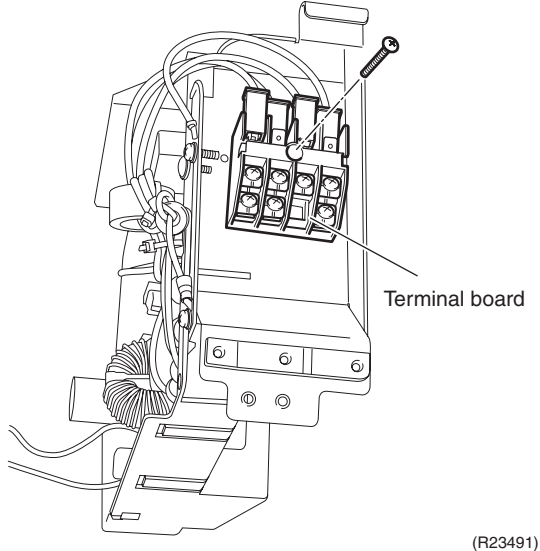

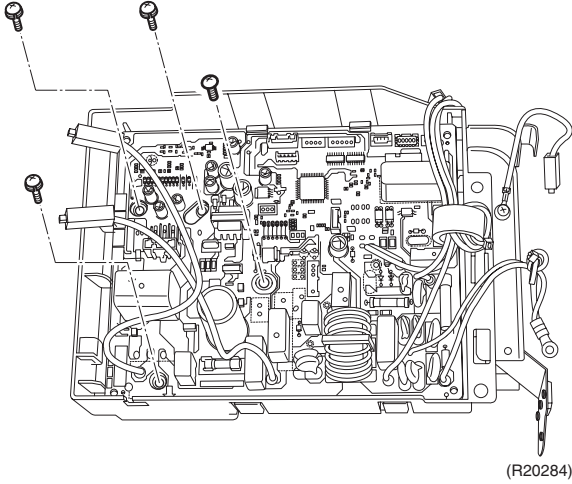
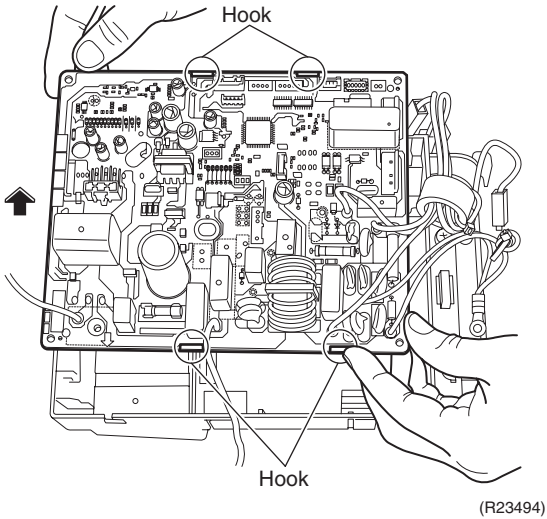
Step	Procedure	Points
5	Remove the 4 screws.	
	 <p>(R20284)</p>	
6	Unfasten the 4 hooks and remove the PCB.	
	 <p>(R23494)</p>	

## 6. Reactor / Partition Plate



### Warning

- ◆ Be sure to wait for 10 minutes or more after turning off all power supplies before disassembling work.

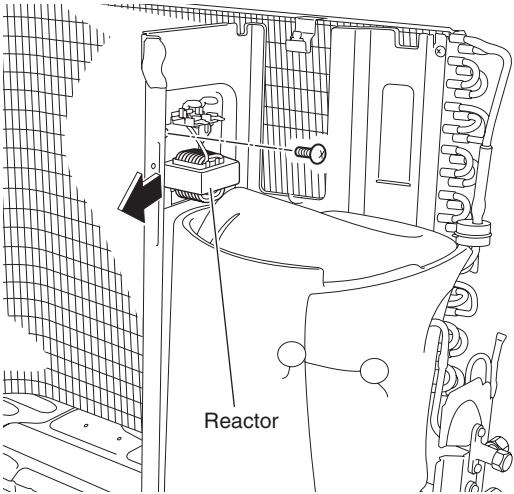
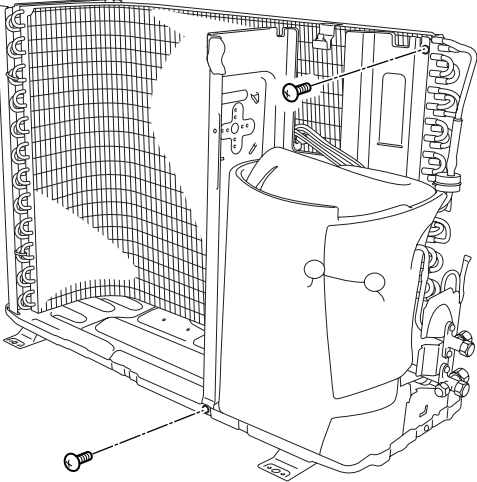
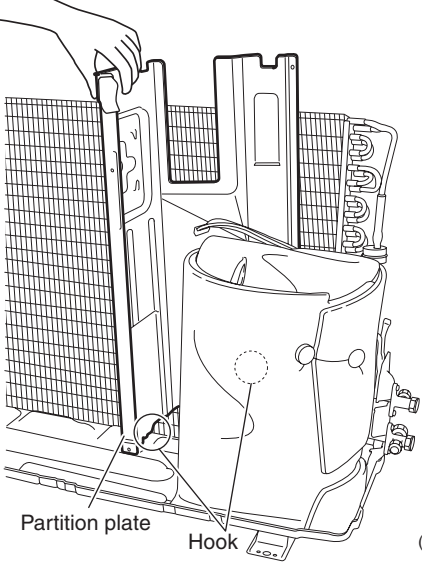
Step	Procedure	Points
1. Remove the reactor. 1 Remove the screw. 2 Slide the reactor to the left and remove the reactor.	 <p style="text-align: center;">Reactor</p> <p style="text-align: right;">(R23495)</p>	
2. Remove the partition plate. 1 Remove the 2 screws. 2 Lift and remove the partition plate.	 <p style="text-align: right;">(R20287)</p>  <p style="text-align: center;">Partition plate      Hook</p> <p style="text-align: right;">(R23496)</p>	<ul style="list-style-type: none"> <li>■ When reassembling, fit the 2 lower hooks into the bottom frame.</li> </ul>

# 7. Sound Blankets



**Warning**

◆ Be sure to wait for 10 minutes or more after turning off all power supplies before disassembling work.

Step	Procedure	Points
1	Remove the sound blanket (top).	<ul style="list-style-type: none"> <li>■ Since the piping ports are torn easily, remove the sound blankets carefully.</li> </ul>
2	Remove the sound blanket (outer).	<ul style="list-style-type: none"> <li>■ The design of the sound blankets varies depending on the model.</li> </ul>
3	Remove the sound blanket (inner).	<ul style="list-style-type: none"> <li>■ Some models have the sound blanket (top inner).</li> </ul>
4	Remove the sound blanket (bottom).	

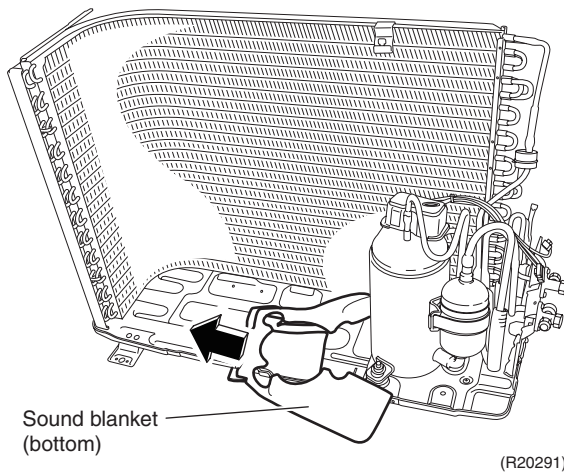
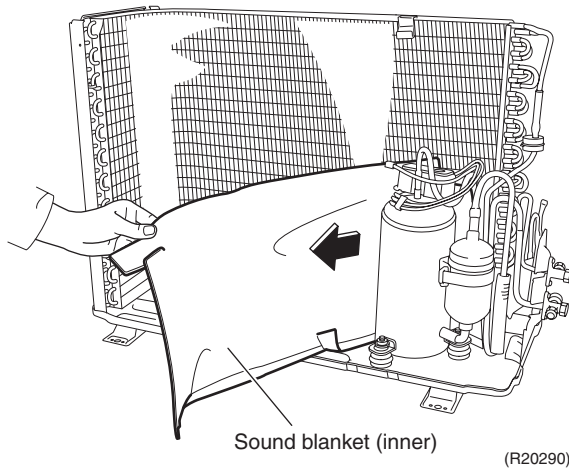
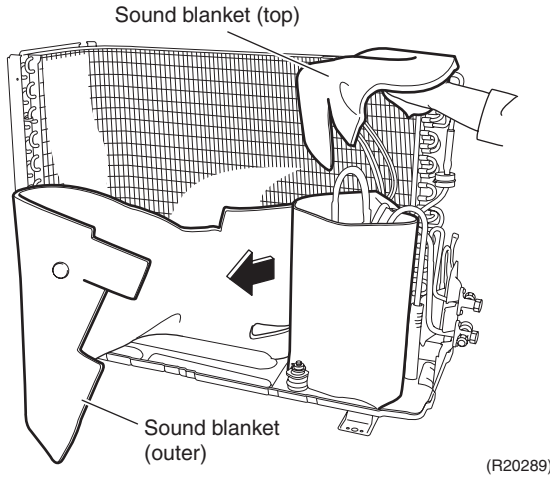



## 8. Capillary Tube



### Warning

- ◆ Be sure to wait for 10 minutes or more after turning off all power supplies before disassembling work.
- ◆ Be careful not to get yourself burnt with the pipes and other parts that are heated by the gas brazing machine.
- ◆ If the refrigerant gas leaks during work, ventilate the room. (If the refrigerant gas is exposed to flames, toxic gas may be generated.)



### Caution

- ◆ From the viewpoint of global environment protection, do not discharge the refrigerant gas in the atmosphere. Make sure to collect all the refrigerant gas.
- ◆ Restore the piping by non-oxidation brazing.



### Note

- ◆ Before working, make sure that the refrigerant gas is empty in the circuit.
- ◆ Be sure to apply nitrogen replacement when heating up the brazed part.
- ◆ Do not use a metal saw for cutting pipes by all means because the sawdust comes into the circuit.
- ◆ When withdrawing the pipes, be careful not to pinch them firmly with pliers. The pipes may get deformed.
- ◆ Provide a protective sheet or a steel plate so that the brazing flame cannot influence peripheries.
- ◆ Be careful so as not to burn the compressor terminals, the name plate, the outdoor heat exchanger fin.
- ◆ In case of difficulty with gas brazing machine
  1. Disconnect the brazed part where is easy to disconnect and restore.
  2. Cut pipes on the main unit with a tube cutter in order to make it easy to disconnect.

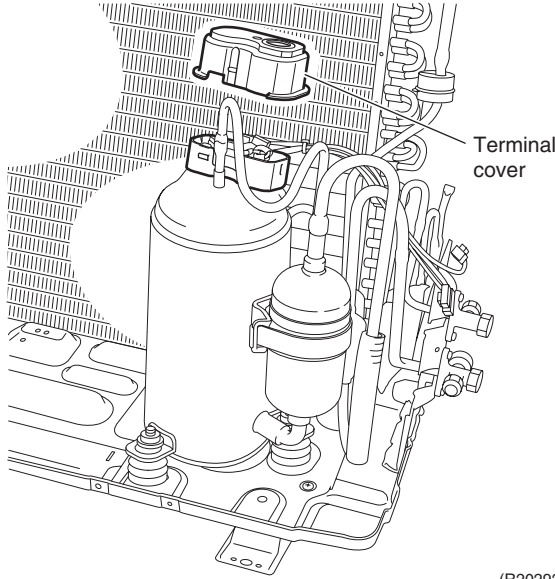
Step	Procedure	Points
1	Remove the terminal cover.  <p style="text-align: right;">(R20292)</p>	



Step	Procedure	Points
2	Disconnect the lead wires of the compressor and the overload protector.	
3	Remove the protection bushing.	
4	Remove the putties, if any.	
5	Heat up the 2 brazed parts and withdraw the piping with pliers.	
6	Remove the capillary tube.	

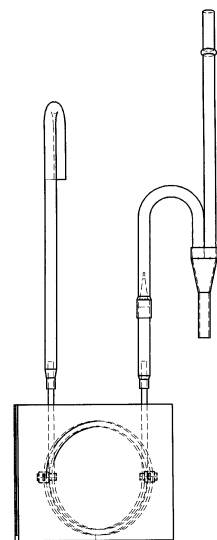
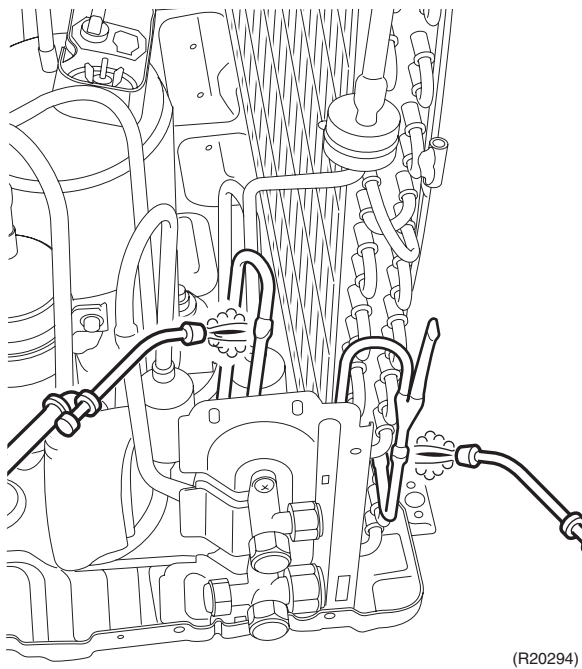
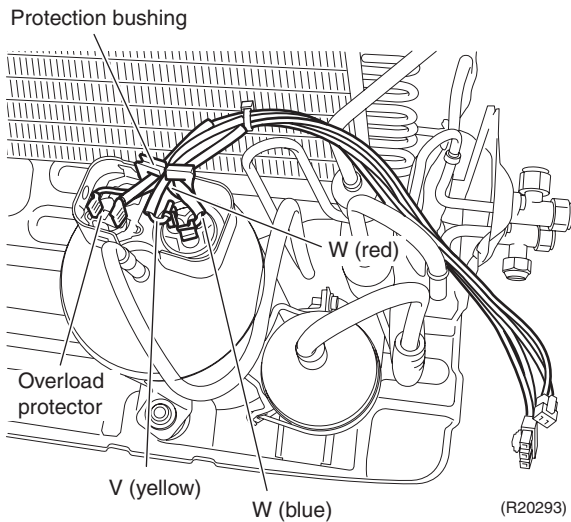

■ The shape of the capillary tube varies depending on the model.

## 9. Compressor



### Warning

- ◆ Be sure to wait for 10 minutes or more after turning off all power supplies before disassembling work.
- ◆ Be careful not to get yourself burnt with the pipes and other parts that are heated by the gas brazing machine.
- ◆ If the refrigerant gas leaks during work, ventilate the room. (If the refrigerant gas is exposed to flames, toxic gas may be generated.)
- ◆ Since it may happen that the refrigerant oil in the compressor catches fire, prepare wet cloth so as to extinguish fire immediately.



### Caution

- ◆ From the viewpoint of global environment protection, do not discharge the refrigerant gas in the atmosphere. Make sure to collect all the refrigerant gas.
- ◆ Restore the piping by non-oxidation brazing.



### Note

- ◆ Before working, make sure that the refrigerant gas is empty in the circuit.
- ◆ Be sure to apply nitrogen replacement when heating up the brazed part.
- ◆ Do not use a metal saw for cutting pipes by all means because the sawdust comes into the circuit.
- ◆ When withdrawing the pipes, be careful not to pinch them firmly with pliers. The pipes may get deformed.
- ◆ Provide a protective sheet or a steel plate so that the brazing flame cannot influence peripheries.
- ◆ Be careful so as not to burn the compressor terminals, the name plate, the outdoor heat exchanger fin.
- ◆ In case of difficulty with gas brazing machine
  1. Disconnect the brazed part where is easy to disconnect and restore.
  2. Cut pipes on the main unit with a tube cutter in order to make it easy to disconnect.

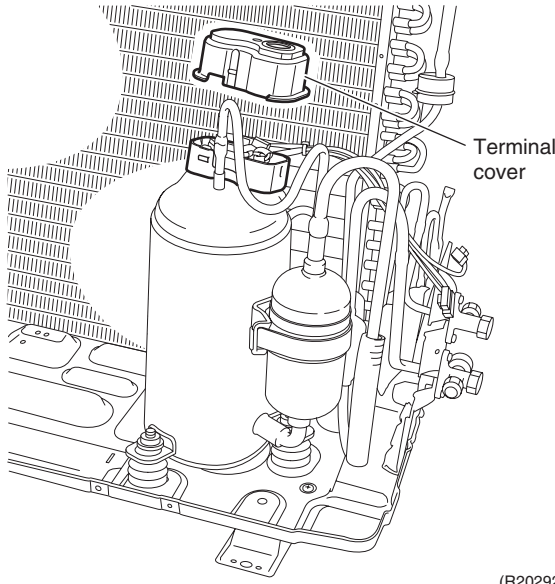
Step	Procedure	Points
1	Remove the terminal cover.  <p style="text-align: right;">(R20292)</p>	

Step	Procedure	Points
2	Disconnect the lead wires of the compressor and the overload protector.	
3	Remove the protection bushing.	
4	Remove the putties, if any.	
5	Heat up the 2 brazed parts and disconnect the pipings.	
6	Remove the 3 nuts of the compressor.	
7	Lift up the compressor and remove it.	

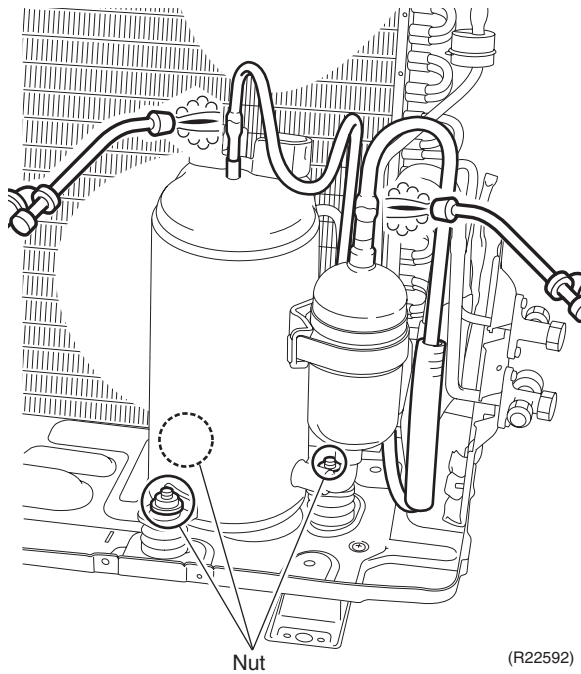
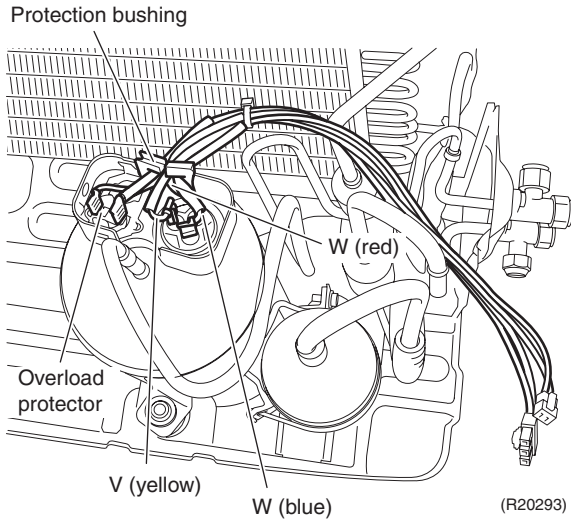

# Revision History

Month / Year	Version	Revised contents
05 / 2014	Si001407E	First edition
11 / 2015	Si001407EA	Model addition: RKP25/35QRV16, RKPA25/35QRV16, RKPD25/35QRV16
07 / 2016	Si001407EB	Model addition: RKH35QRV16, RKH35RRV16

Warning



- Daikin products are manufactured for export to numerous countries throughout the world. Prior to purchase, please confirm with your local authorised importer, distributor and/or retailer whether this product conforms to the applicable standards, and is suitable for use, in the region where the product will be used. This statement does not purport to exclude, restrict or modify the application of any local legislation.
- Ask a qualified installer or contractor to install this product. Do not try to install the product yourself. Improper installation can result in water or refrigerant leakage, electrical shock, fire or explosion.
- Use only those parts and accessories supplied or specified by Daikin. Ask a qualified installer or contractor to install those parts and accessories. Use of unauthorised parts and accessories or improper installation of parts and accessories can result in water or refrigerant leakage, electrical shock, fire or explosion.
- Read the user's manual carefully before using this product. The user's manual provides important safety instructions and warnings. Be sure to follow these instructions and warnings.

If you have any enquiries, please contact your local importer, distributor and/or retailer.

### Cautions on product corrosion

1. Air conditioners should not be installed in areas where corrosive gases, such as acid gas or alkaline gas, are produced.
2. If the outdoor unit is to be installed close to the sea shore, direct exposure to the sea breeze should be avoided. If you need to install the outdoor unit close to the sea shore, contact your local distributor.

### Dealer

### **DAIKIN INDUSTRIES, LTD.**

Head Office:  
Umeda Center Bldg., 2-4-12, Nakazaki-Nishi,  
Kita-ku, Osaka, 530-8323 Japan

Tokyo Office:  
JR Shinagawa East Bldg., 2-18-1, Konan,  
Minato-ku, Tokyo, 108-0075 Japan

<http://www.daikin.com/products/ac/>

©All rights reserved