

# REMOVAL PROCEDURE



## S E R V I C E M A N U A L

### 2.0/2.5/3.5 kW Class

-  Outdoor Unit
-  Inverter
-  Pair Type



# **Service Manual Removal Procedure**

## **Outdoor Unit**

### **●Heat Pump**

**ARX20J3V1B**

**ARX25J3V1B**

**ARX35J3V1B**

**RX20J3V1B**

**RX25J3V1B**

**RX35J3V1B**

# Table of Contents

1. Outer Panels .....	2
2. Outdoor Fan / Fan Motor.....	4
3. Electrical Box / PCBs .....	6
4. Sound Blankets.....	14
5. Four Way Valve.....	16
6. Compressor.....	19



**Note:** ♦ The illustrations may be slightly different depending on the model.

# 1. Outer Panels



**Warning**

◆ Be sure to wait for 10 minutes or more after turning off all power supplies before disassembling work.

Step	Procedure	Points
1	<p>Remove the screw of the stop valve cover. Pull down the stop valve cover and remove it.</p>	<ul style="list-style-type: none"> <li>■ The stop valve cover is united with the shield plate.</li> <li>■ When reassembling, make sure to fit the 3 hooks.</li> </ul>
2	<p>Remove the 3 screws and remove the top panel.</p>	
3	<p>Remove the 6 screws of the front panel.</p>	

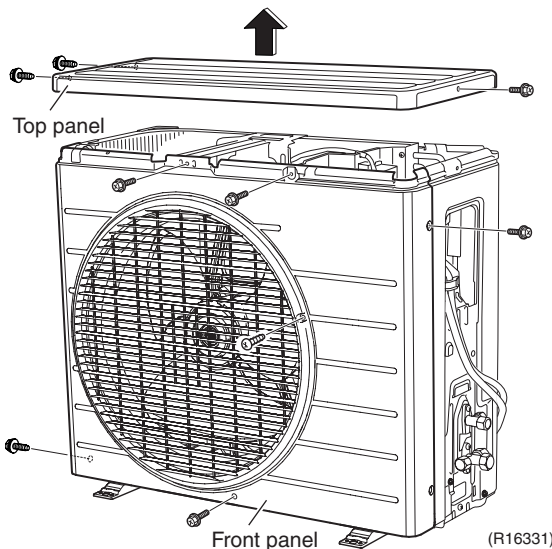
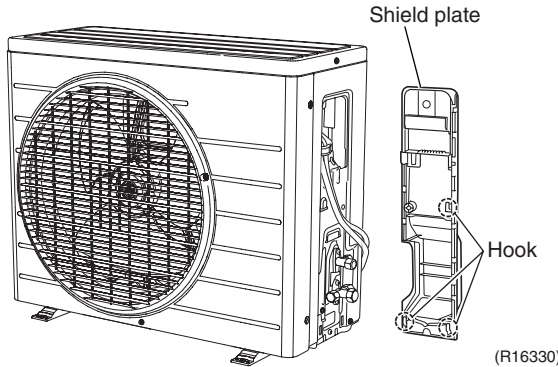
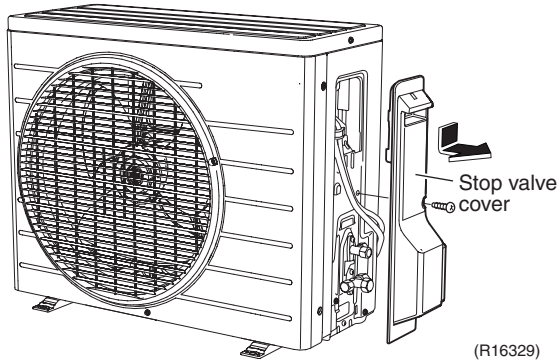

Step	Procedure	Points
4	Lift up the left side and unfasten the hooks.	
5	Unfasten the right side hooks and remove the front panel.	
6	The discharge grille has 2 projections to prevent rotating. Press the projections from the rear side and rotate the discharge grille.	
7	Unfasten the 6 hooks and remove the discharge grille.	

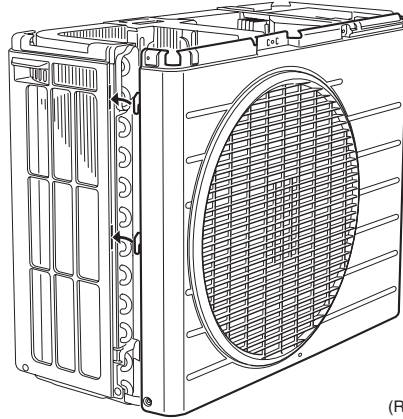

(R18741)

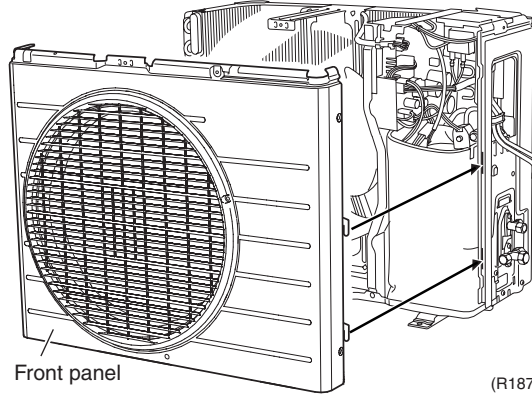

Front panel

(R18742)

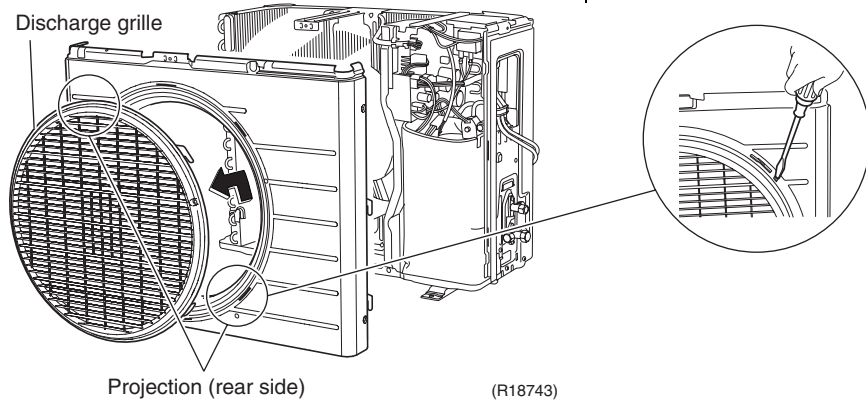

Discharge grille

Projection (rear side)

(R18743)

## 2. Outdoor Fan / Fan Motor



**Warning**

◆ Be sure to wait for 10 minutes or more after turning off all power supplies before disassembling work.

Step	Procedure	Points
<p>1. Remove the outdoor fan.</p> <p>1 Remove the nut of the outdoor fan.</p> <p>2 Remove the outdoor fan.</p>	<p>(R18350)</p>	<p>■ Nut size: M6</p> <p>(R18954)</p> <p>■ When reassembling, align the ▼ mark of the outdoor fan with the D-cut section of the motor shaft.</p>
<p>2. Remove the fan motor.</p> <p>1 Disconnect the connector [S70].</p> <p>2 Release the fan motor lead wire from the hooks.</p> <p>3 Remove the screw and remove the fan motor fixing frame.</p>	<p>(R17338)</p> <p>(R11957)</p>	<p>[S70]: fan motor</p> <p>■ When reassembling, put the fan motor lead wire through the back of the fan motor so as not to be entangled with the outdoor fan.</p> <p>Lead wire Outdoor fan</p> <p>(R3249)</p>

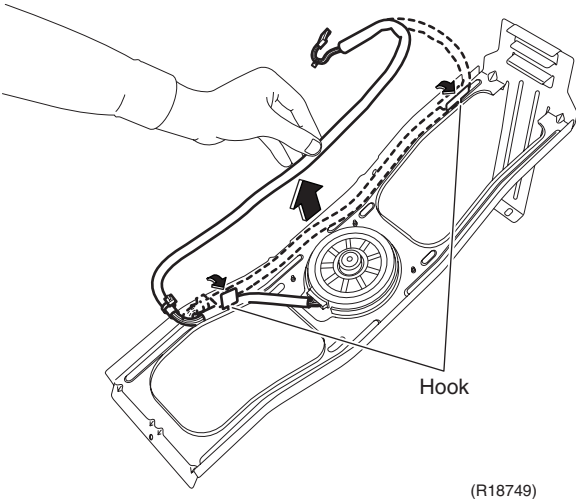
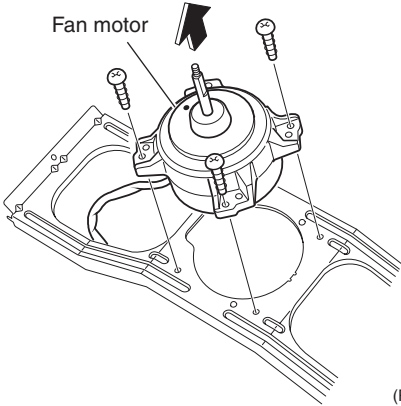
Step	Procedure	Points
4	Release the fan motor lead wire from the 2 hooks.	
	 <p>The diagram shows a hand pulling a lead wire away from a hook on the fan housing. A dashed line indicates the wire's path. An arrow points to the hook. The label 'Hook' is positioned below the hook. The reference code '(R18749)' is located at the bottom right of the diagram.</p>	
5	Remove the 3 screws and remove the fan motor.	
	 <p>The diagram shows the fan motor being lifted out of the housing. An arrow points to the fan motor. Three screws are shown being removed from the motor's base. The label 'Fan motor' is positioned above the motor. The reference code '(R14691)' is located at the bottom right of the diagram.</p>	

### 3. Electrical Box / PCBs



**Warning**

◆ Be sure to wait for 10 minutes or more after turning off all power supplies before disassembling work.

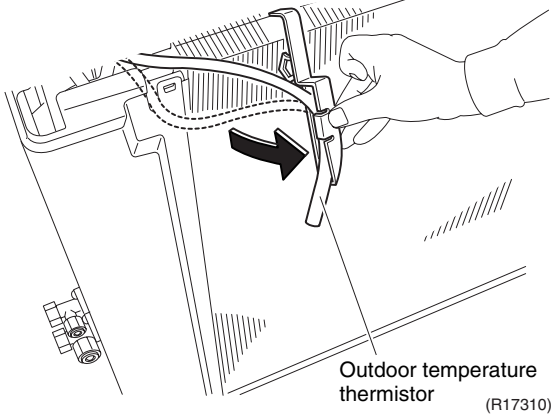
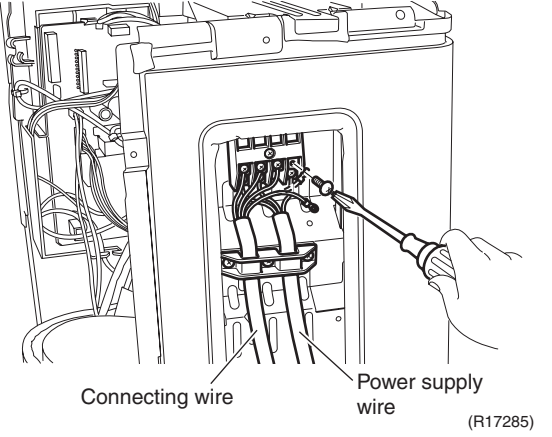
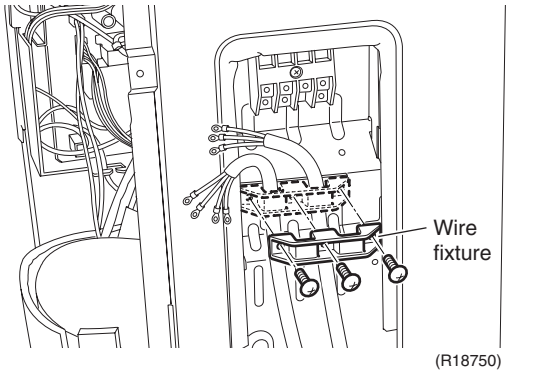
Step	Procedure	Points
<p>1. Remove the right side panel.</p>		<p>■ The outdoor temperature thermistor is hooked on the guard net.</p>
<p>1 Release the outdoor temperature thermistor.</p>		
<p>2 Remove the screws and release the connecting wire and the power supply wire.</p>		
<p>3 Remove the 3 screws and remove the wire fixture.</p>		

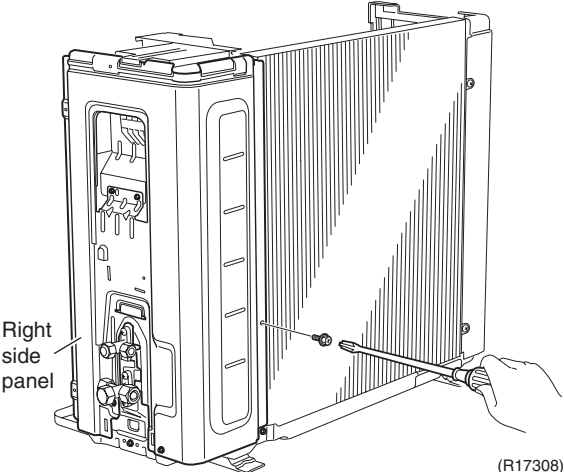
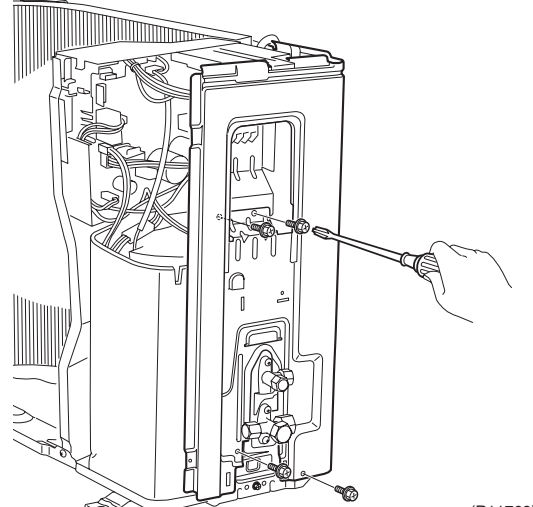
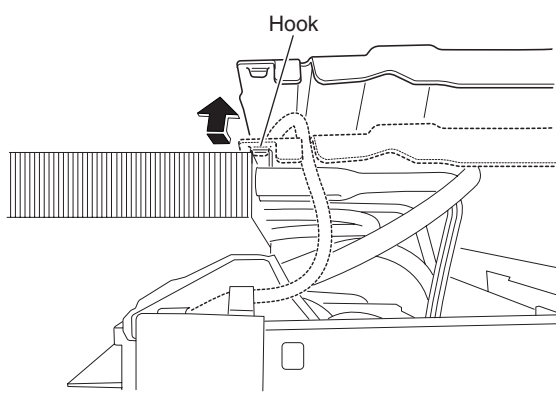
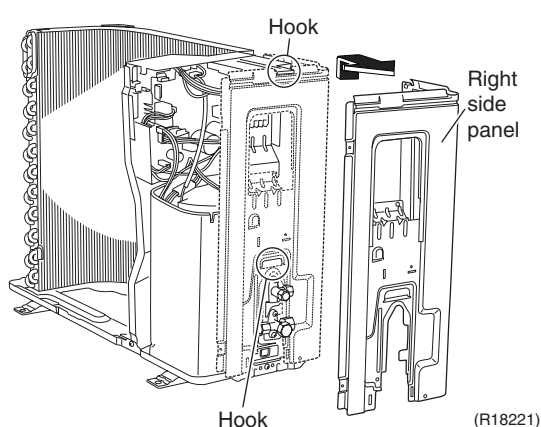

Step	Procedure	Points
4	<p>Remove the screw on the rear side of the right side panel.</p> 	
5	<p>Remove the 4 screws on the right side panel.</p> 	
6	<p>Unfasten the hook on the rear side.</p> 	<p>■ When reassembling, make sure to fit the hook.</p>
7	<p>Unfasten the 2 hooks, and remove the right side panel.</p> 	

Step	Procedure	Points
2.	Remove the electrical box.	[S80]: four way valve coil
1	Disconnect the connector [S80].	
2	Disconnect the connector [S40].	[S40]: overload protector
3	Disconnect the connector [S20].	[S20]: electronic expansion valve coil
4	Disconnect the relay connector for the compressor.	

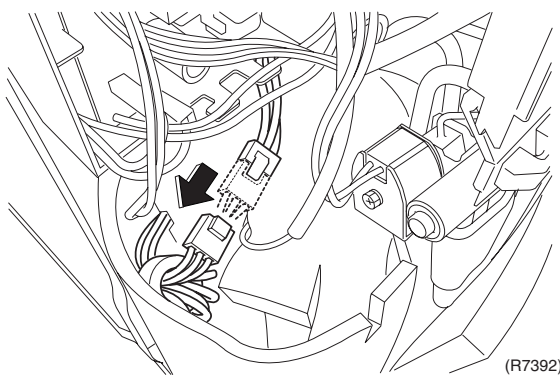
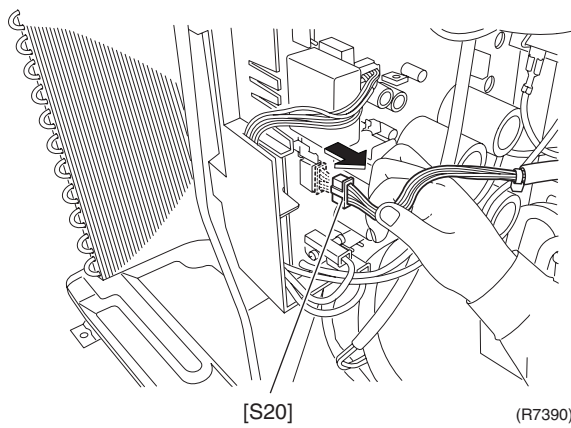
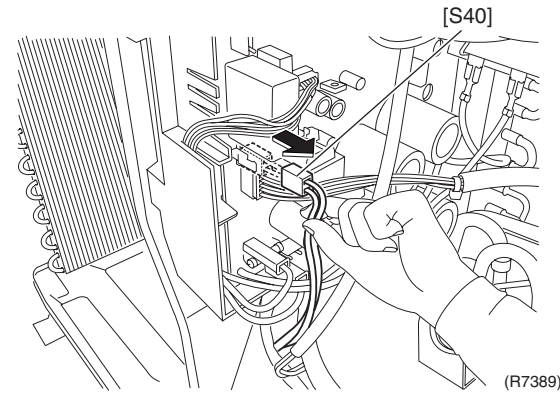
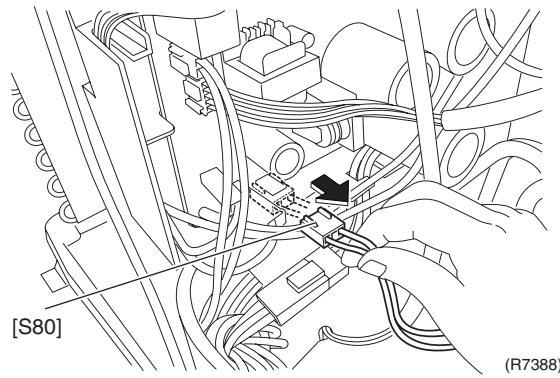

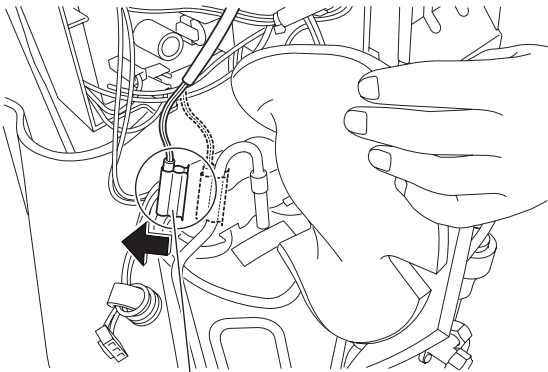
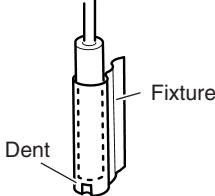
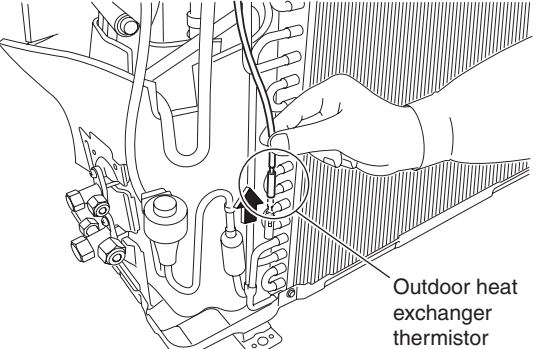
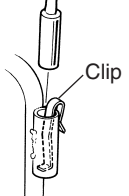
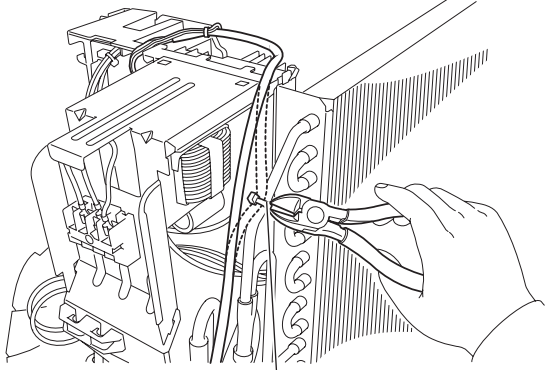
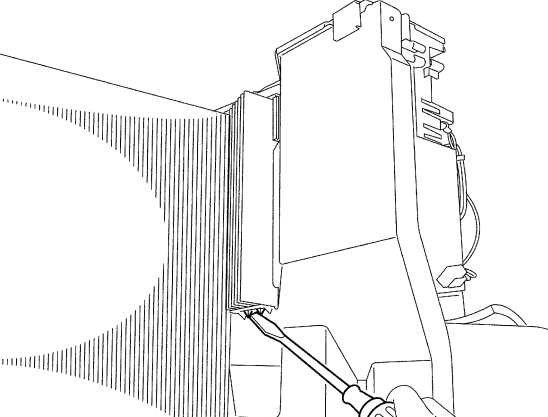
Step	Procedure	Points
5	Release the discharge pipe thermistor.	<ul style="list-style-type: none"> <li>■ Pay attention so as not to lose the fixture for the thermistor.</li> <li>■ When reassembling, do not insert the thermistor up to the dent of fixture.</li> </ul>
	 <p style="text-align: center;">Discharge pipe thermistor (R18744)</p>	 <p style="text-align: center;">(R18746)</p>
6	Pull out the outdoor heat exchanger thermistor.	<ul style="list-style-type: none"> <li>■ Pay attention so as not to lose the clip for the thermistor.</li> </ul>
	 <p style="text-align: center;">Outdoor heat exchanger thermistor (R18745)</p>	 <p style="text-align: center;">(R18747)</p>
7	Cut the clamp.	
	 <p style="text-align: center;">Clamp (R7395)</p>	
8	Unfasten the hook from the partition plate with a flat screwdriver.	<ul style="list-style-type: none"> <li>■ The electrical box can be removed by lifting itself without a screwdriver.</li> </ul>
	 <p style="text-align: center;">(R7318)</p>	

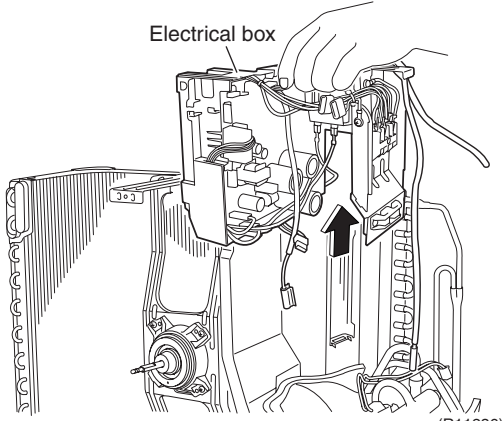
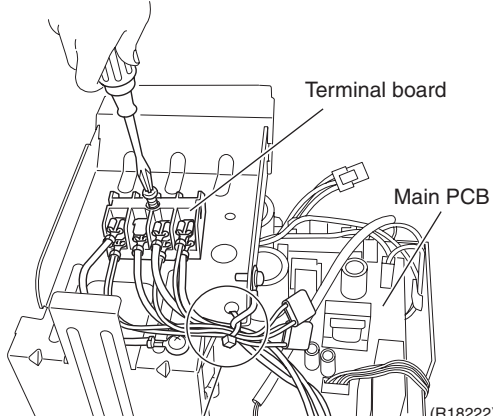
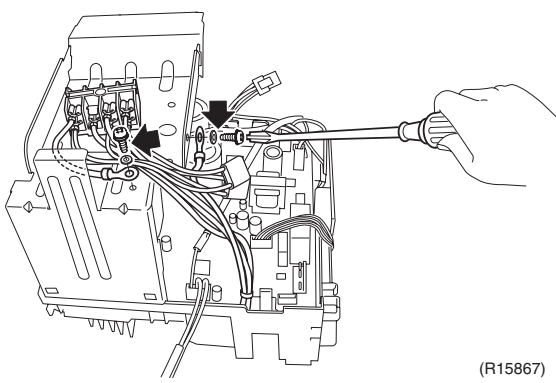
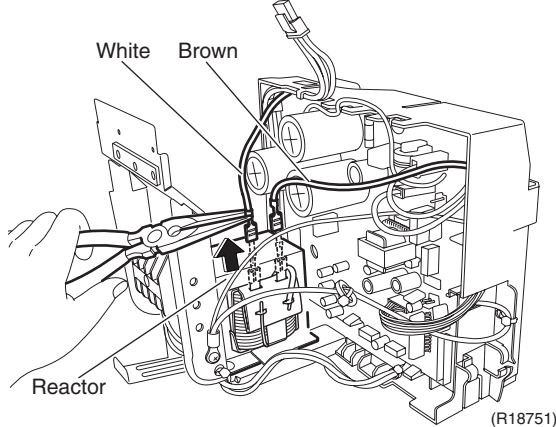
Step	Procedure	Points
9	Lift and remove the electrical box.  <p style="text-align: right;">(R11236)</p>	
3. Remove the main PCB.	<p>1 Remove the screw on the terminal board.</p> <p>2 Cut the clamp.</p>  <p style="text-align: right;">(R18222)</p> <p>3 Remove the 2 screws of the earth / ground wires.</p>  <p style="text-align: right;">(R15867)</p> <p>4 Disconnect the 2 terminals of the reactor.</p>  <p style="text-align: right;">(R18751)</p>	<p>1: black, upper                      2: white, lower                      3: red, upper                      (⊥) : green / yellow, lower</p>

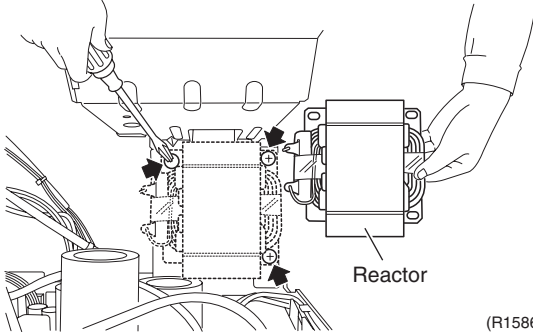
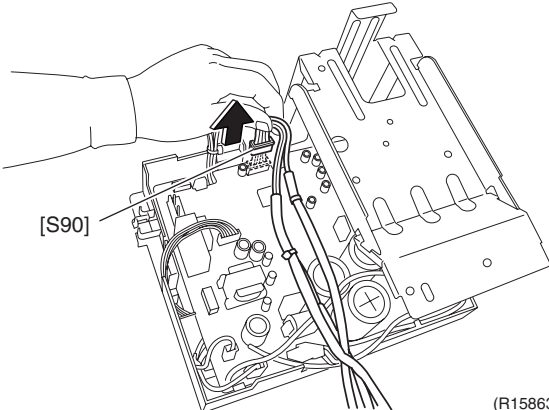
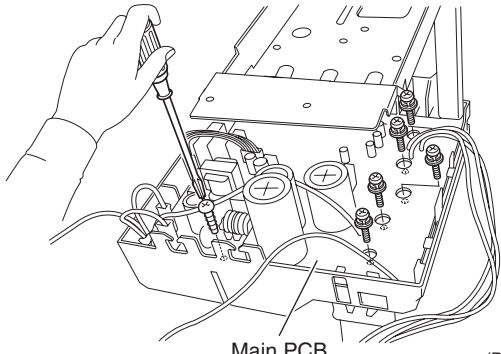
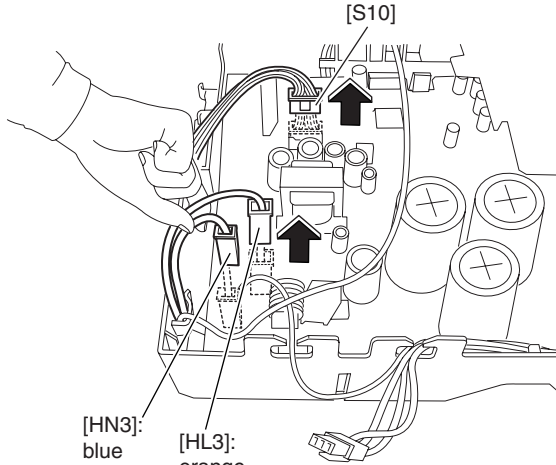
Step	Procedure	Points
5	<p>Remove the 3 screws to remove the reactor.</p>  <p style="text-align: right;">(R15862)</p>	
6	<p>Disconnect the connector [S90].</p>  <p style="text-align: right;">(R15863)</p>	<p>[S90]: thermistors</p>
7	<p>Remove the 6 screws.</p>  <p style="text-align: right;">(R15864)</p>	
8	<p>Disconnect the 3 connectors [S10] [HL3] [HN3].</p>  <p style="text-align: right;">(R17309)</p>	<p>[S10] [HL3] [HN3]: filter PCB</p>

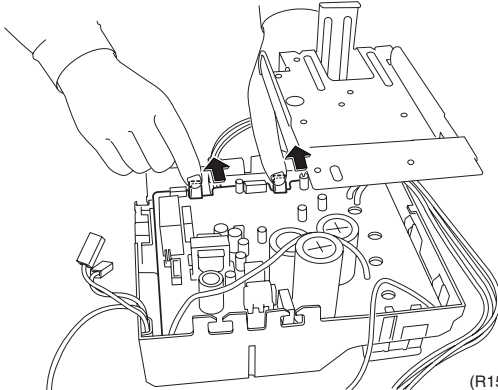
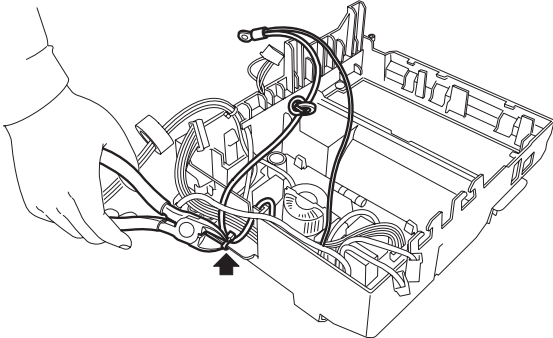
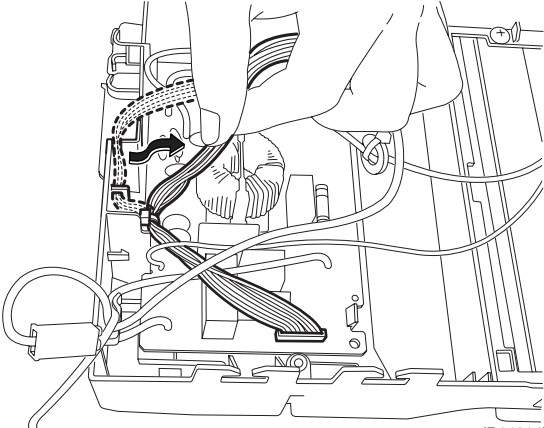
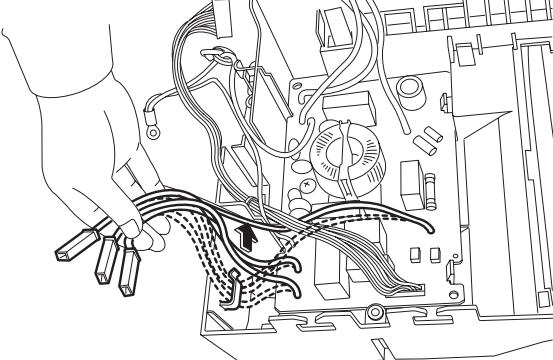
Step	Procedure	Points
<p>9 Unfasten the 2 hooks.</p> <p>10 Lift and remove the main PCB.</p>	 <p>(R15869)</p>	
<p>4. Remove the filter PCB.</p> <p>1 Cut the clamp.</p> <p>2 Release the harnesses from the hooks.</p>	 <p>(R14813)</p>  <p>(R14814)</p>  <p>(R18752)</p>	

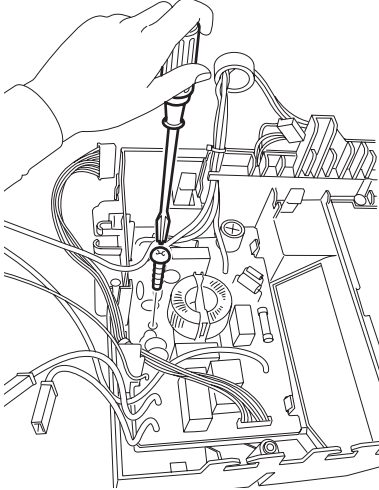
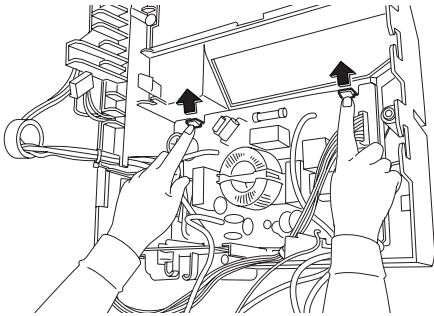
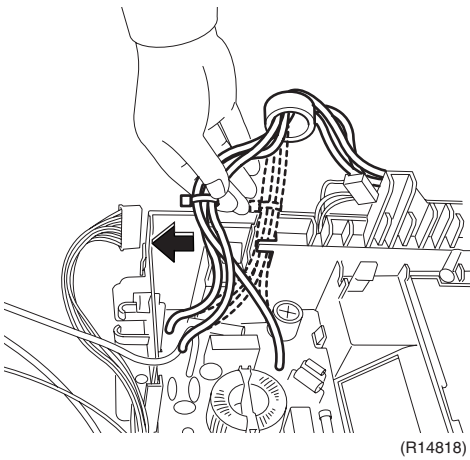
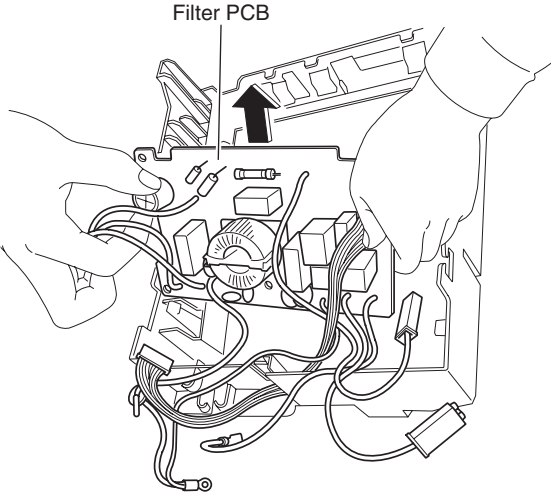
Step	Procedure	Points
3	Remove the screw.	
	 <p>(R14816)</p>	
4	Unfasten the 2 hooks.	
	 <p>(R14817)</p>	
5	Release the harnesses.	
	 <p>(R14818)</p>	
6	Remove the filter PCB.	
	<p>Filter PCB</p>  <p>(R14819)</p>	

# 4. Sound Blankets



**Warning**

◆ Be sure to wait for 10 minutes or more after turning off all power supplies before disassembling work.

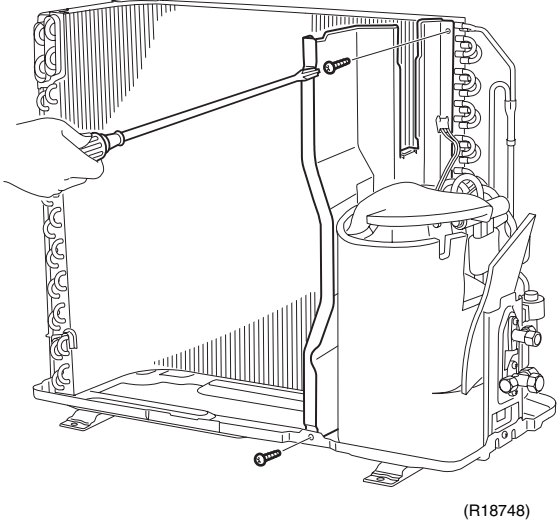
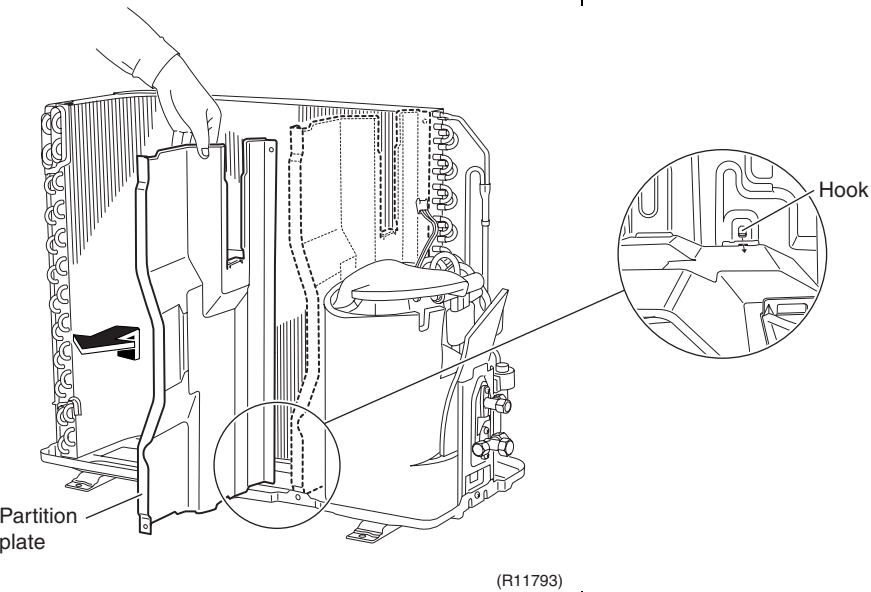
Step	Procedure	Points
1. Remove the partition plate.	 <p>(R18748)</p>	
1 Remove the 2 screws.	 <p>Partition plate</p> <p>Hook</p> <p>(R11793)</p>	<p>■ When reassembling, fit the lower hook into the bottom frame.</p>
2 The partition plate has a hook on the lower side. Lift and pull the partition plate and remove it.		

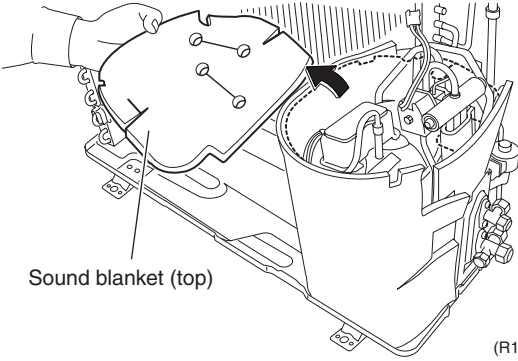
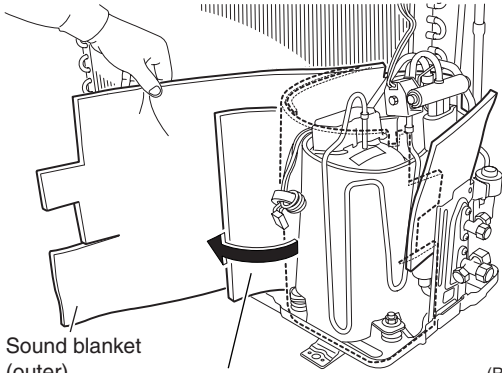
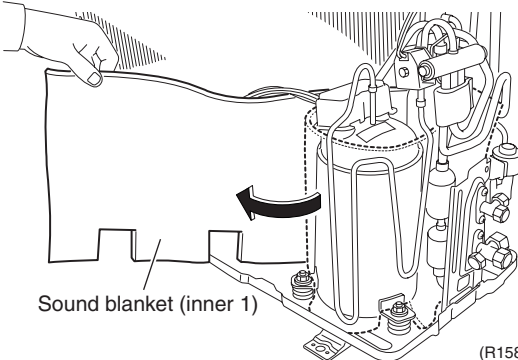

Step	Procedure	Points
2. Remove the sound blankets.	 <p>Sound blanket (top)</p> <p>(R11963)</p>	<ul style="list-style-type: none"> <li>Since the piping ports on the sound blanket are torn easily, remove the blanket carefully.</li> </ul>
1 Lift and remove the sound blanket (top).		
2 Pull the sound blankets (outer, inner 2) out.	 <p>Sound blanket (outer)</p> <p>Sound blanket (inner 2)</p> <p>(R18224)</p>	
3 Pull the sound blanket (inner 1) out.	 <p>Sound blanket (inner 1)</p> <p>(R15871)</p>	

# 5. Four Way Valve



**Warning**

- ♦ Be sure to wait for 10 minutes or more after turning off all power supplies before disassembling work.
- ♦ Be careful not to get yourself burnt with the pipes and other parts that are heated by the gas brazing machine.
- ♦ If the refrigerant gas leaks during work, ventilate the room. (If the refrigerant gas is exposed to flames, toxic gas may be generated.)



**Caution**



- ♦ From the viewpoint of global environment protection, do not discharge the refrigerant gas in the atmosphere. Make sure to collect all the refrigerant gas.
- ♦ **Cautions for restoration**
  1. Restore the piping by non-oxidation brazing.
  2. It is required to prevent the carbonization of the oil inside the four way valve and the deterioration of the gaskets affected by heat. (Keep below 120°C (248°F).) For the sake of this, wrap the four way valve with wet cloth and provide water so that the cloth does not dry.

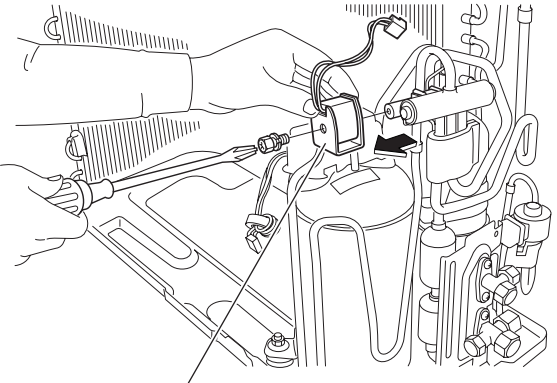

**Note**

- ♦ Before working, make sure that the refrigerant gas is empty in the circuit.
- ♦ Be sure to apply nitrogen replacement when heating up the brazed part.
- ♦ Do not use a metal saw for cutting pipes by all means because the sawdust comes into the circuit.
- ♦ When withdrawing the pipes, be careful not to pinch them firmly with pliers. The pipes may get deformed.
- ♦ Provide a protective sheet or a steel plate so that the brazing flame cannot influence peripheries.
- ♦ Be careful so as not to burn the compressor terminals, the name plate, the outdoor heat exchanger fin.
- ♦ **In case of difficulty with gas brazing machine**
  1. Disconnect the brazed part where is easy to disconnect and restore.
  2. Cut pipes on the main unit with a tube cutter in order to make it easy to disconnect.

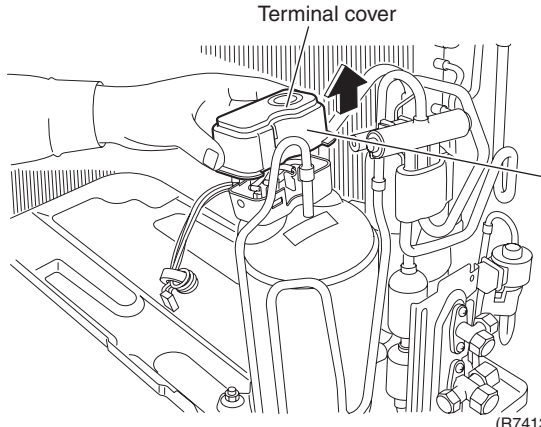
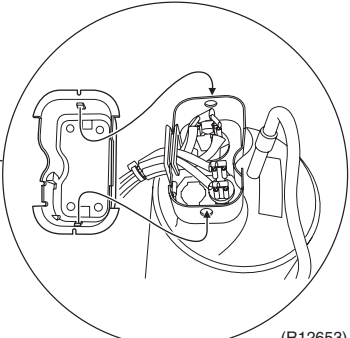
Step	Procedure	Points
<p>1. Remove the peripheries.</p> <p>1 Remove the screw and remove the four way valve coil.</p>	 <p style="text-align: center;">Four way valve coil (R7412)</p>	

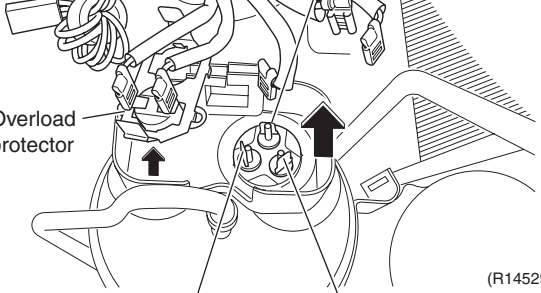
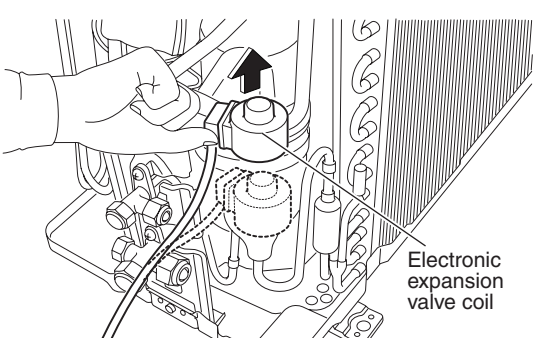
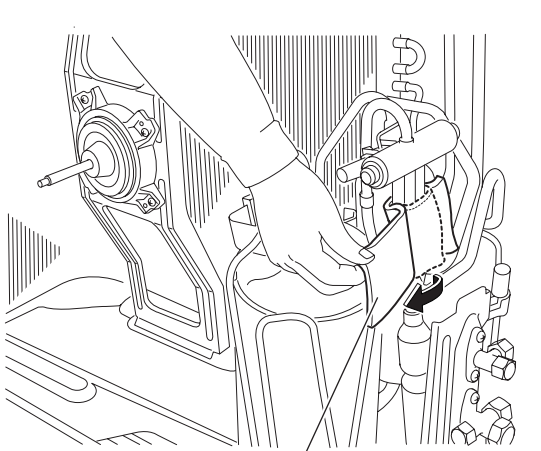
Step	Procedure	Procedure	Points
2	Remove the terminal cover.		 <p data-bbox="1085 582 1436 672"> <b>■ There are 2 hooks at the inner side of the terminal cover.</b> </p>
3	Disconnect the lead wires of the compressor.		
4	Remove the overload protector.		
5	Remove the electronic expansion valve coil.		
6	Remove the putty.		

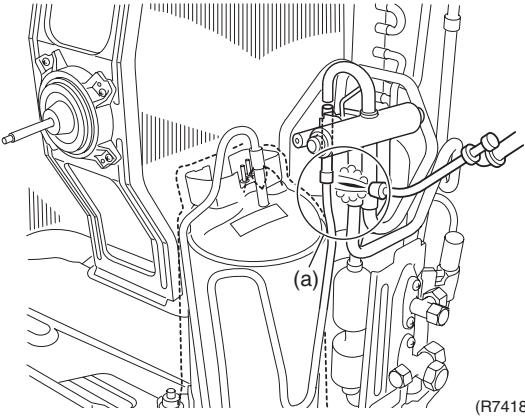
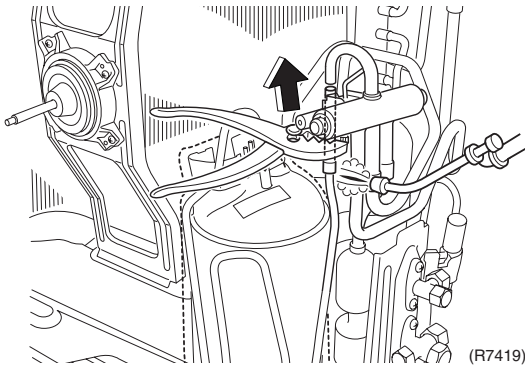
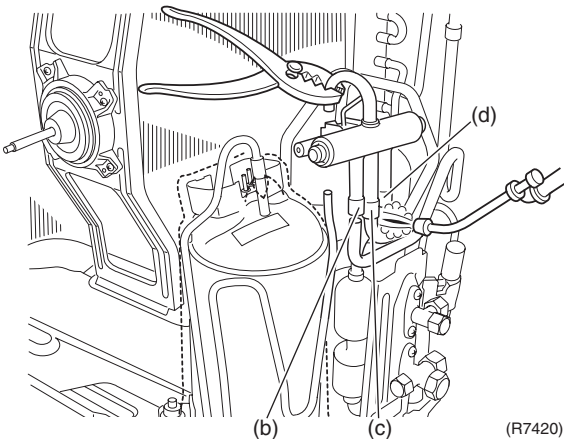
Step	Procedure	Points
2.	Remove the four way valve.	
1	<p>Heat up the brazed part (a) and withdraw the piping with pliers.</p>  <p>(R7418)</p>  <p>(R7419)</p> <p>2 Heat up the 3 brazed parts of the four way valve. Disconnect the point (b) first.</p> <p>3 Disconnect the points (c) and (d).</p>  <p>(R7420)</p>	

# 6. Compressor



**Warning**

- ♦ Be sure to wait for 10 minutes or more after turning off all power supplies before disassembling work.
- ♦ Be careful not to get yourself burnt with the pipes and other parts that are heated by the gas brazing machine.
- ♦ If the refrigerant gas leaks during work, ventilate the room. (If the refrigerant gas is exposed to flames, toxic gas may be generated.)
- ♦ Since it may happen that the refrigerant oil in the compressor catches fire, prepare wet cloth so as to extinguish fire immediately.



**Caution**

- ♦ From the viewpoint of global environment protection, do not discharge the refrigerant gas in the atmosphere. Make sure to collect all the refrigerant gas.
- ♦ Cautions for restoration
  1. Restore the piping by non-oxidation brazing.
  2. It is required to prevent the carbonization of the oil inside the four way valve and the deterioration of the gaskets affected by heat. (Keep below 120°C (248°F).) For the sake of this, wrap the four way valve with wet cloth and provide water so that the cloth does not dry.



**Note**

- ♦ Before working, make sure that the refrigerant gas is empty in the circuit.
- ♦ Be sure to apply nitrogen replacement when heating up the brazed part.
- ♦ Do not use a metal saw for cutting pipes by all means because the sawdust comes into the circuit.
- ♦ When withdrawing the pipes, be careful not to pinch them firmly with pliers. The pipes may get deformed.
- ♦ Provide a protective sheet or a steel plate so that the brazing flame cannot influence peripheries.
- ♦ Be careful so as not to burn the compressor terminals, the name plate, the outdoor heat exchanger fin.
- ♦ In case of difficulty with gas brazing machine
  1. Disconnect the brazed part where is easy to disconnect and restore.
  2. Cut pipes on the main unit with a tube cutter in order to make it easy to disconnect.

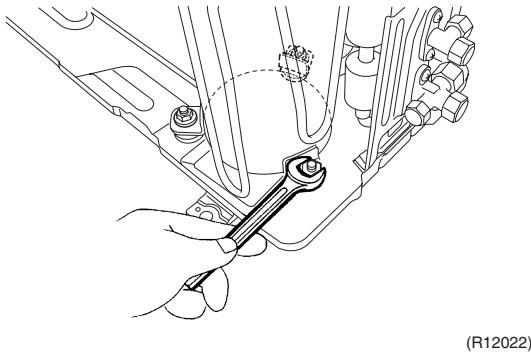
Step	Procedure	Points
1	Remove the 3 nuts of the compressor.	 <p style="text-align: right;">(R12022)</p>

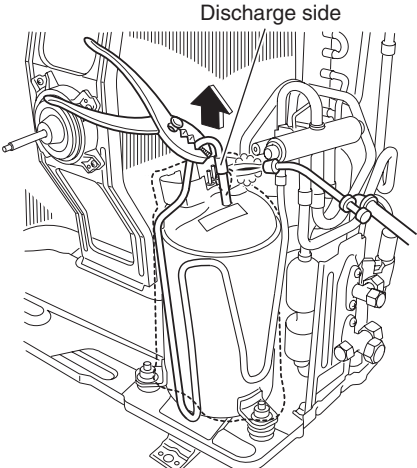
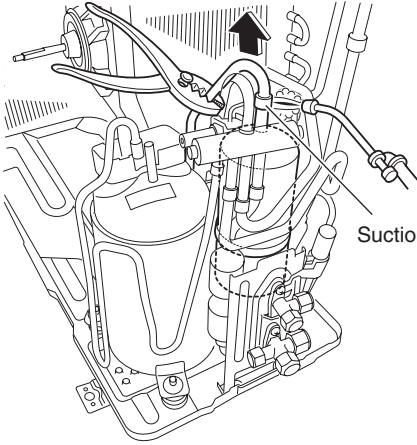
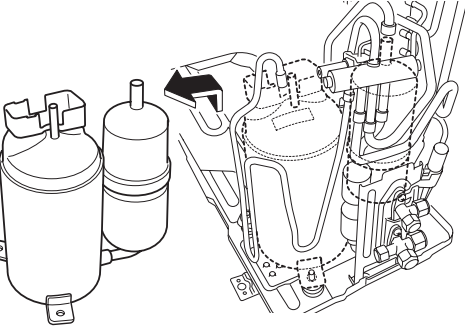
Step	Procedure	Points
2	Heat up the brazed part of the discharge side and disconnect.	
	 <p style="text-align: center;">Discharge side</p> <p style="text-align: right;">(R7422)</p>	
3	Heat up the brazed part of the suction side and disconnect.	
	 <p style="text-align: right;">Suction side</p> <p style="text-align: right;">(R7423)</p>	
4	Lift the compressor up and remove it.	
	 <p style="text-align: right;">(R7424)</p>	

# Revision History

Month / Year	Version	Revised contents
04 / 2013	Si001276	First edition

Warning



- Daikin products are manufactured for export to numerous countries throughout the world. Prior to purchase, please confirm with your local authorised importer, distributor and/or retailer whether this product conforms to the applicable standards, and is suitable for use, in the region where the product will be used. This statement does not purport to exclude, restrict or modify the application of any local legislation.
- Ask a qualified installer or contractor to install this product. Do not try to install the product yourself. Improper installation can result in water or refrigerant leakage, electrical shock, fire or explosion.
- Use only those parts and accessories supplied or specified by Daikin. Ask a qualified installer or contractor to install those parts and accessories. Use of unauthorised parts and accessories or improper installation of parts and accessories can result in water or refrigerant leakage, electrical shock, fire or explosion.
- Read the User's Manual carefully before using this product. The User's Manual provides important safety instructions and warnings. Be sure to follow these instructions and warnings.

If you have any enquiries, please contact your local importer, distributor and/or retailer.

### Cautions on product corrosion

1. Air conditioners should not be installed in areas where corrosive gases, such as acid gas or alkaline gas, are produced.
2. If the outdoor unit is to be installed close to the sea shore, direct exposure to the sea breeze should be avoided. If you need to install the outdoor unit close to the sea shore, contact your local distributor.

### Dealer

### **DAIKIN INDUSTRIES, LTD.**

Head Office:  
Umeda Center Bldg., 2-4-12, Nakazaki-Nishi,  
Kita-ku, Osaka, 530-8323 Japan

Tokyo Office:  
JR Shinagawa East Bldg., 2-18-1, Konan,  
Minato-ku, Tokyo, 108-0075 Japan

[http://www.daikin.com/global\\_ac/](http://www.daikin.com/global_ac/)

©All rights reserved