

# REMOVAL PROCEDURE



## S E R V I C E M A N U A L

### 24000/28000 Btu/h Class

-  Outdoor Unit
-  Inverter
-  Pair Type



# **Service Manual Removal Procedure**

## **Outdoor Unit**

### **Applicable Models**

#### **●Cooling Only**

**RKD24HV2S**

**RKD28HV2S**

# Table of Contents

1. Removal of Outer Panels .....	2
2. Removal of Electrical Box .....	15
3. Removal of PCBs .....	20
4. Removal of Fan Motor.....	25
5. Removal of Electronic Expansion Valve Coil / Thermistors .....	26
6. Removal of Reactor .....	28
7. Removal of Sound Blankets.....	29
8. Removal of Compressor .....	31



**Note:**

♦ The illustrations may be slightly different depending on the model.

# 1. Removal of Outer Panels

**Procedure**

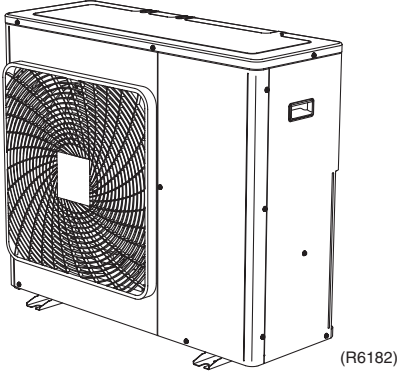
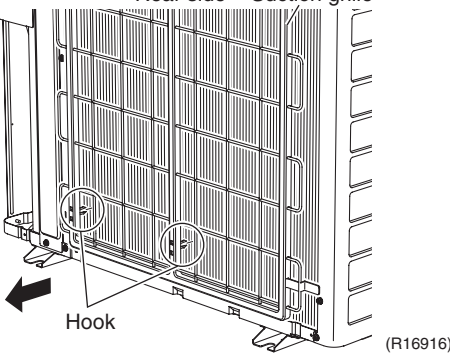
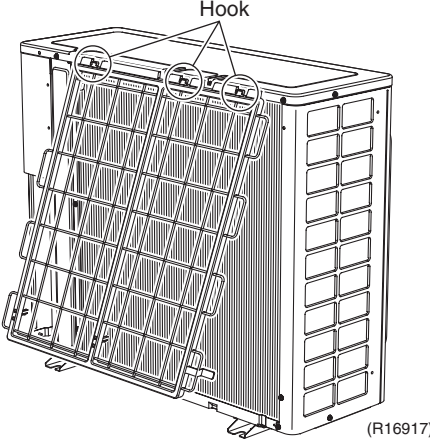
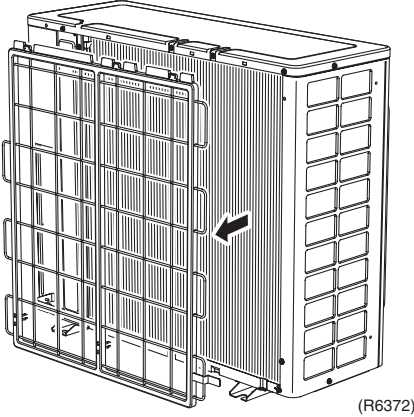

**Warning** Be sure to wait for 10 minutes or more after turning off all power supplies before disassembling work.

Step	Procedure	Points
1. Appearance features		
2. Remove the suction grille.	<p>1 Unfasten the 2 hooks at the bottom.</p>  <p>2 Slide the suction grille downward to unfasten the 3 top hooks.</p>  <p>3 Remove the suction grille.</p> 	<p>■ The hooks are secured in the clearances of the outdoor heat exchanger fins.</p>

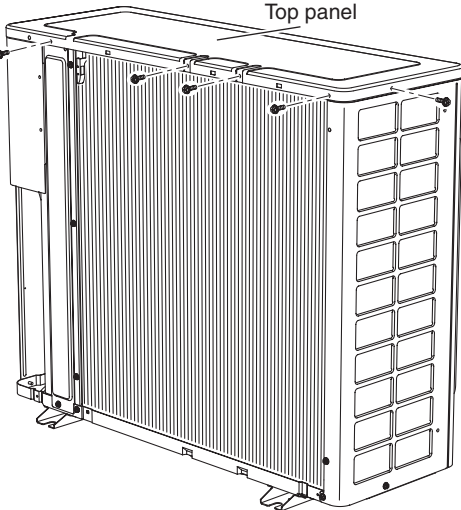
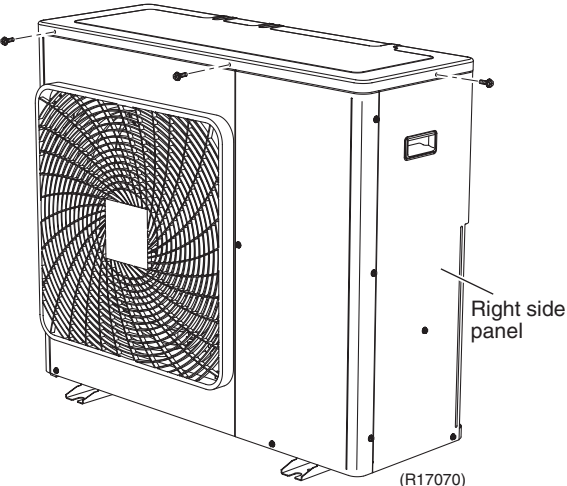
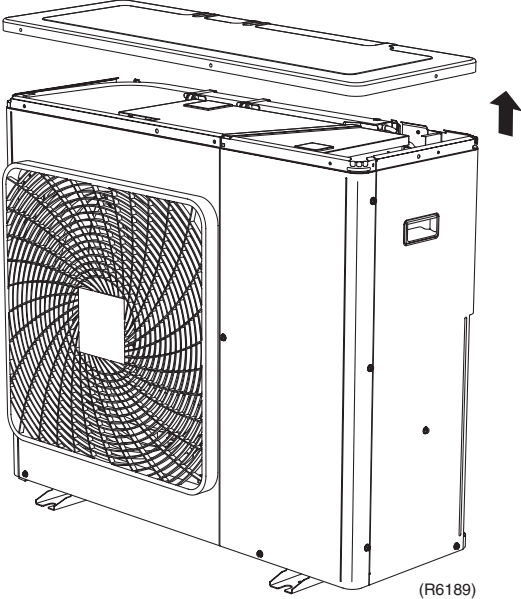
Step	Procedure	Points
3. Remove the top panel.	<p data-bbox="151 248 448 344">1 Remove the 4 screws on the back and the screw on the left side.</p>  <p data-bbox="151 797 456 927">2 Remove the 2 screws on the front and the screw on the right side panel.</p>  <p data-bbox="151 1352 440 1413">3 Lift the top panel and remove it.</p> 	

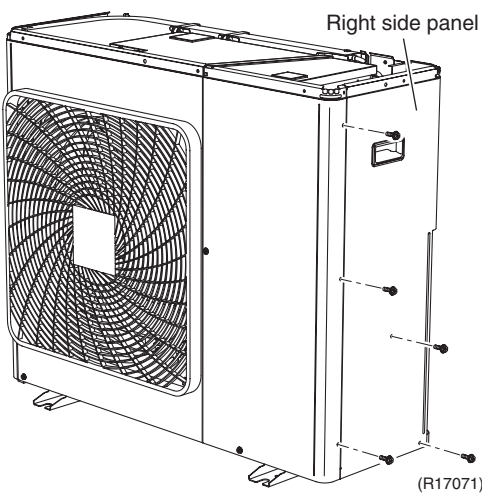
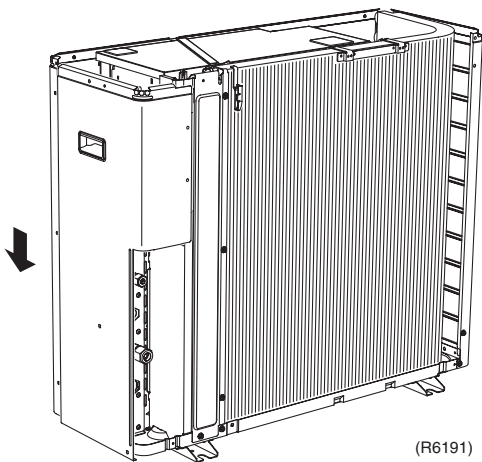
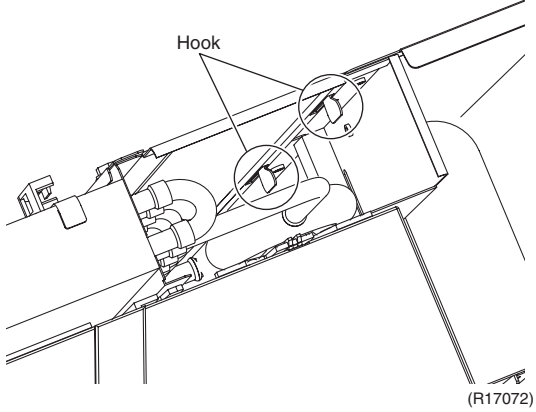
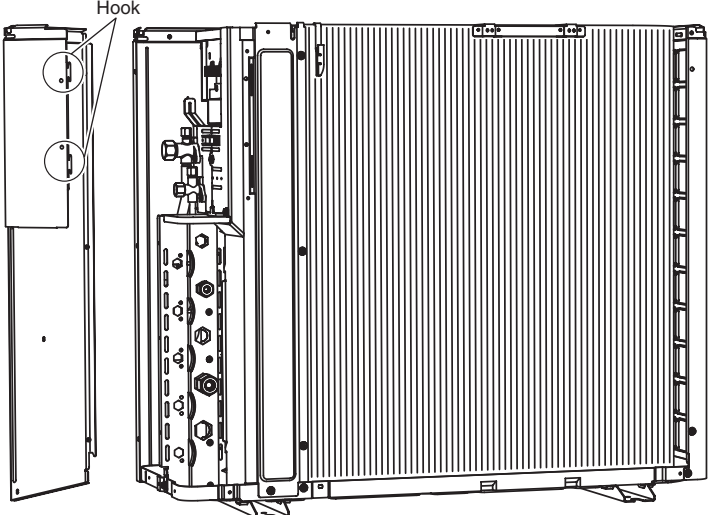
Step	Procedure	Points
4. Remove the right side panel.	 <p>Right side panel</p> <p>(R17071)</p>	
1 Remove the 5 screws.	 <p>(R6191)</p>	
2 Slide the right side panel downward to unfasten the 2 hooks on the rear side.	 <p>Hook</p> <p>(R17072)</p>	
	 <p>Hook</p> <p>(R17073)</p>	

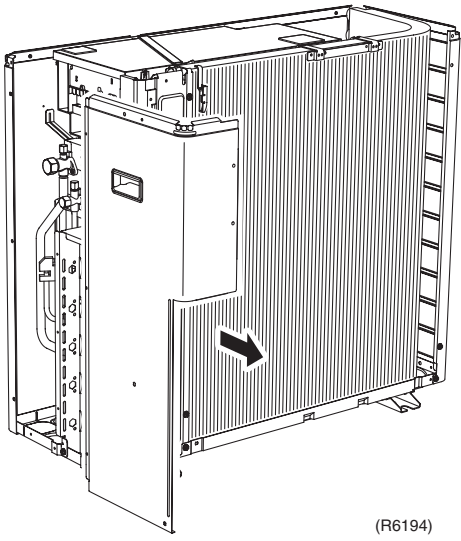
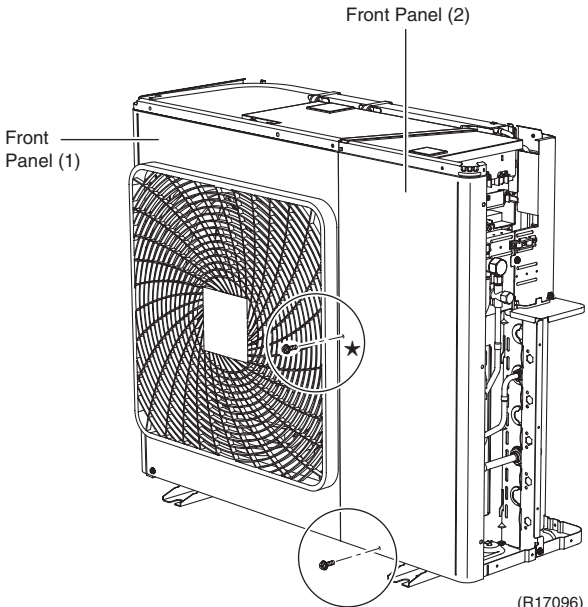
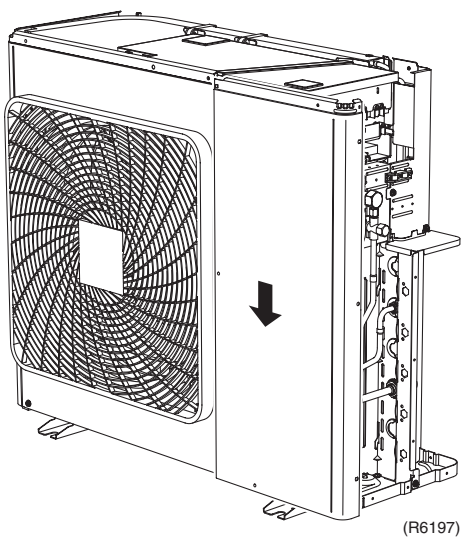
Step	Procedure	Points
3	<p>Remove the right side panel.</p>  <p>(R6194)</p>	
5.	<p>Remove the front panel (2)</p>	
1	<p>Remove the 2 screws.</p>  <p>(R17096)</p>	<p>★: This screw is M5(3) × 16</p>
2	<p>Slide the front panel (2) downward to unfasten the hooks.</p>  <p>(R6197)</p>	

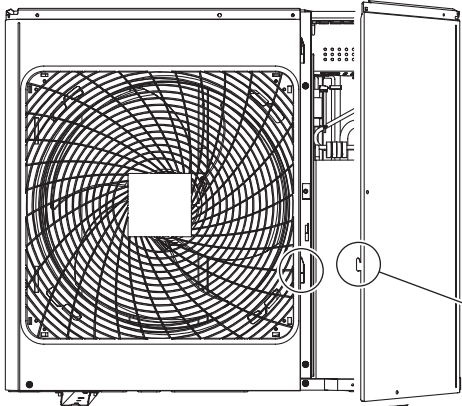
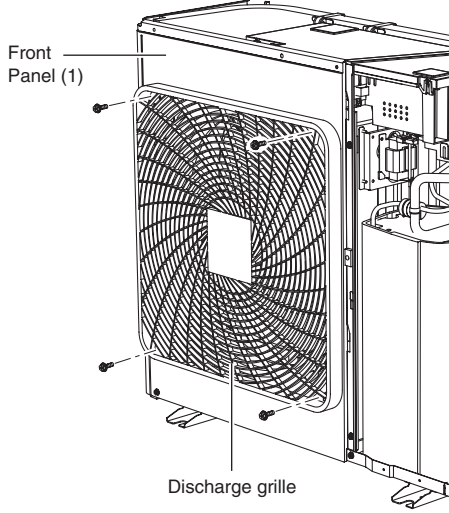
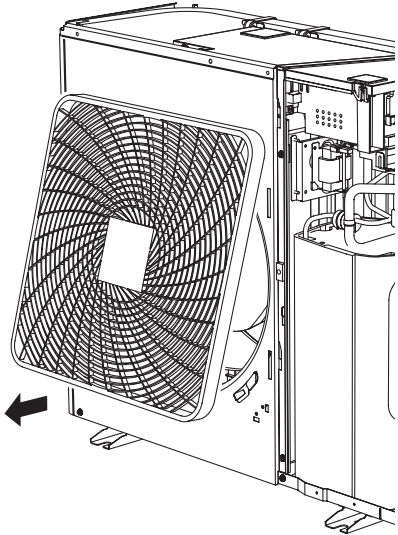
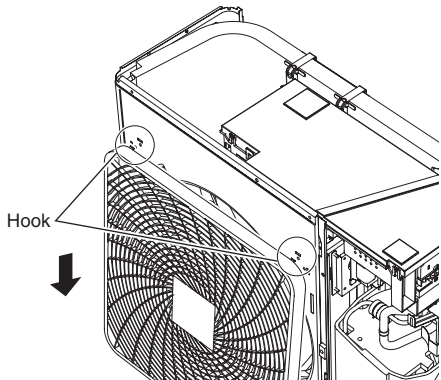
Step	Procedure	Points
3	<p>Remove the front panel (2).</p>  <p style="text-align: right;">Hook</p> <p style="text-align: right;">(R17074)</p>	
6.	<p>Remove the front panel (1)</p> <p>1 Remove the 4 screws on the discharge grille.</p>  <p style="text-align: right;">(R16875)</p> <p>2 Pull the bottom of the discharge grille.</p>  <p style="text-align: right;">(R16876)</p> <p>3 Slide the discharge grille downward to unfasten the 2 hooks at the top.</p>  <p style="text-align: right;">Hook</p> <p style="text-align: right;">(R16877)</p>	<p>■ Remove the discharge grille and the outdoor fan before removing the front panel (1).</p>

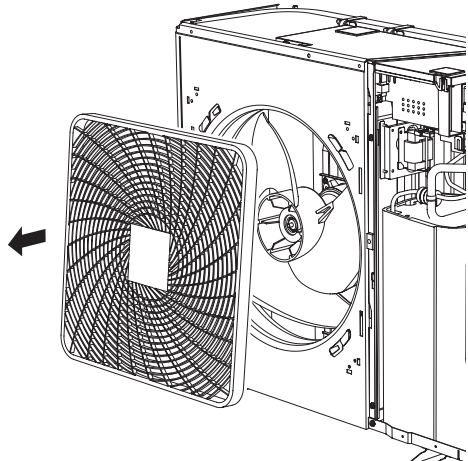
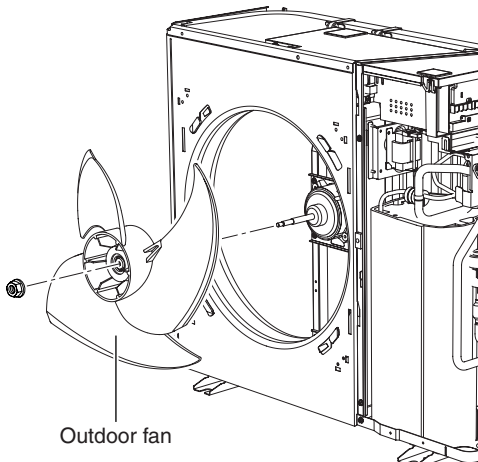
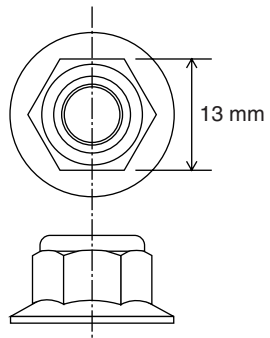
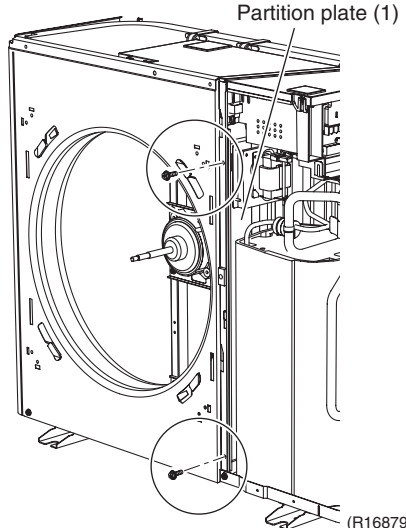

Step	Procedure	Procedure	Points
4	Remove the discharge grille.	 <p>(R6204)</p>	
5	Remove the nut of the outdoor fan.	 <p>Outdoor fan</p> <p>(R16878)</p>	<p>■ Nut size : M8</p>  <p>13 mm</p> <p>(R12301)</p>
6	Remove the 2 screws on the partition plate (1).	 <p>Partition plate (1)</p> <p>(R16879)</p>	

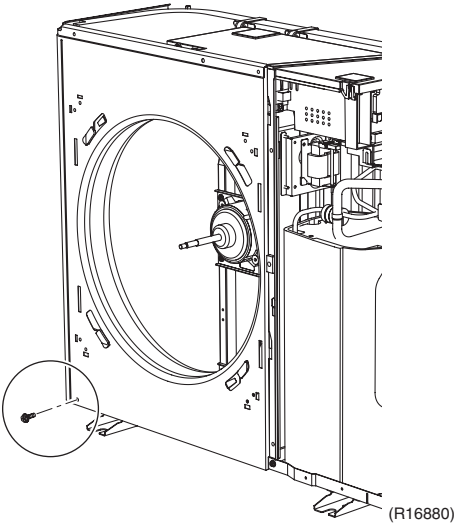
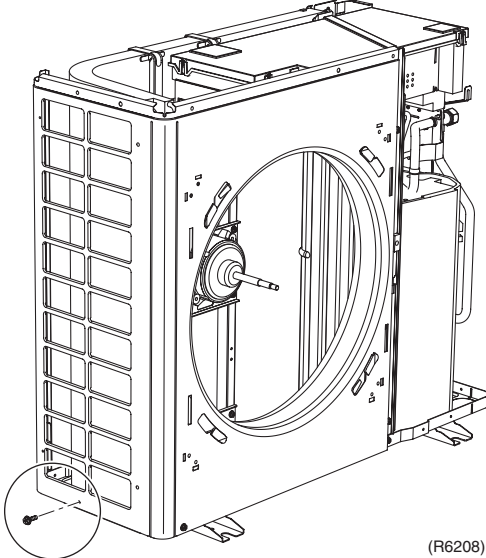
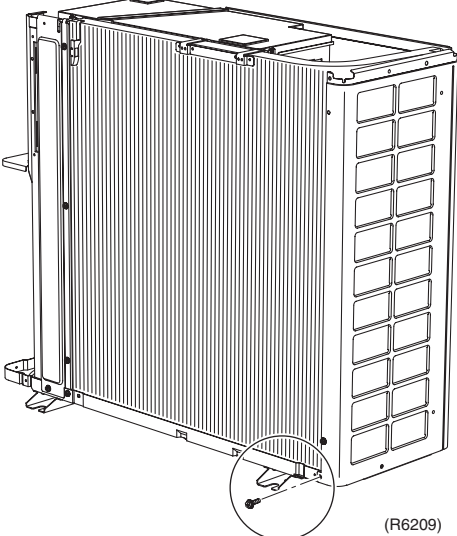
Step	Procedure	Points
7	Remove the screw at the bottom left of the front.	
		
8	Remove the screw at the bottom of the left side.	
		
9	Remove the screw at the bottom of the rear side.	
		

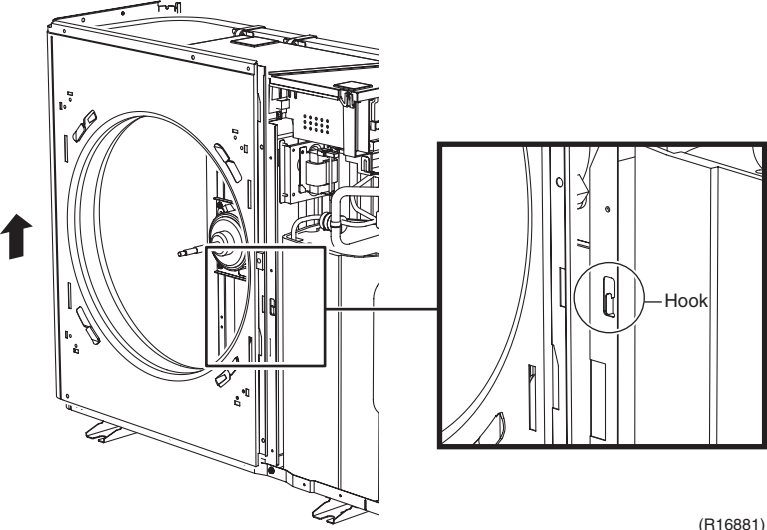
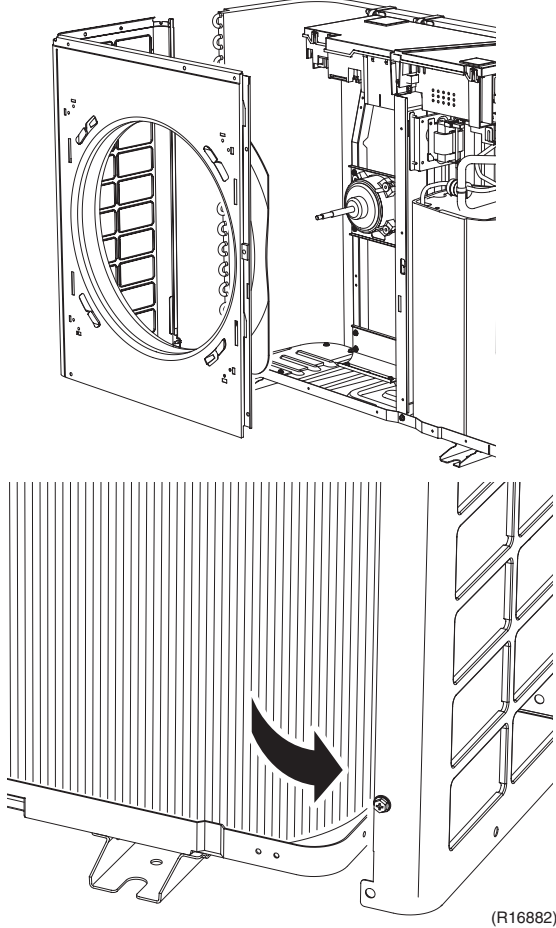
Step	Procedure	Points
10	Lift the front panel (1).	<ul style="list-style-type: none"> <li>■ The front panel (1) has a hook on its front.</li> </ul>
 <p>(R16881)</p>		
11	Remove the front panel (1).	<ul style="list-style-type: none"> <li>■ Be sure to detach the front panel (1) carefully so as not to deform it.</li> </ul>
 <p>(R16882)</p>		

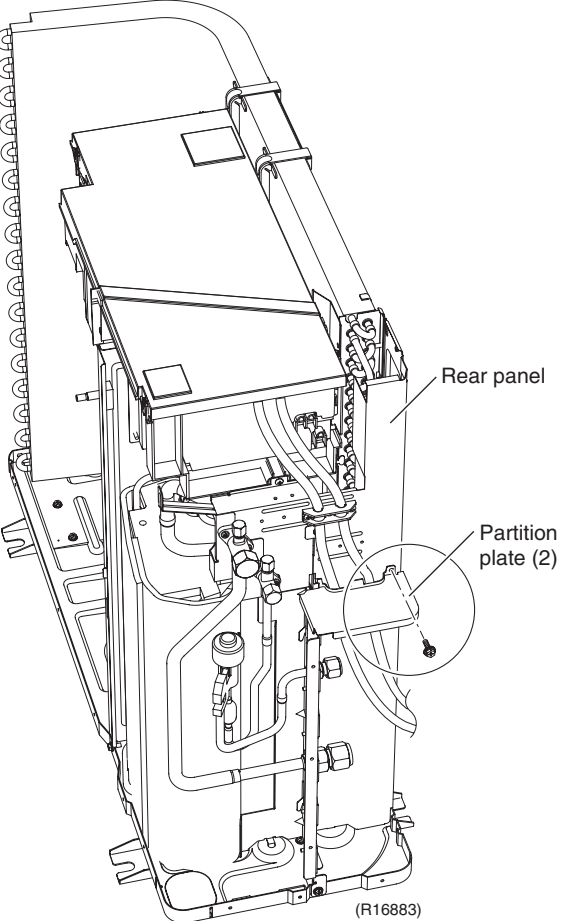
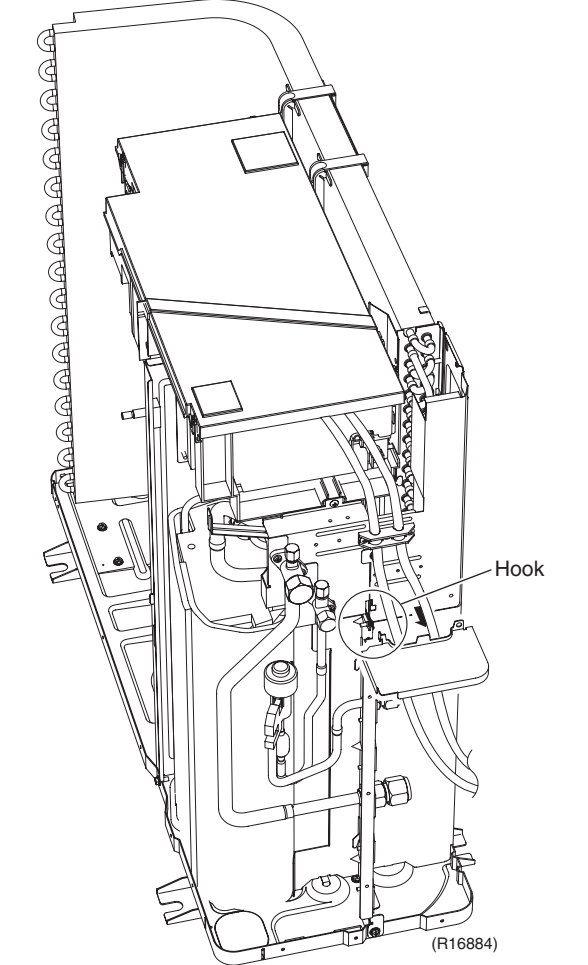
Step	Procedure	Points
7. Remove the rear panel.	<p data-bbox="151 248 172 277">1</p> <p data-bbox="199 248 448 315">Remove the screw on the partition plate (2).</p>  <p data-bbox="932 591 1038 620">Rear panel</p> <p data-bbox="970 748 1054 799">Partition plate (2)</p> <p data-bbox="847 1122 916 1144">(R16883)</p>	
2	<p data-bbox="199 1149 448 1249">Slide the partition plate (2) to the left and remove it.</p>  <p data-bbox="995 1727 1038 1756">Hook</p> <p data-bbox="922 2101 991 2123">(R16884)</p>	

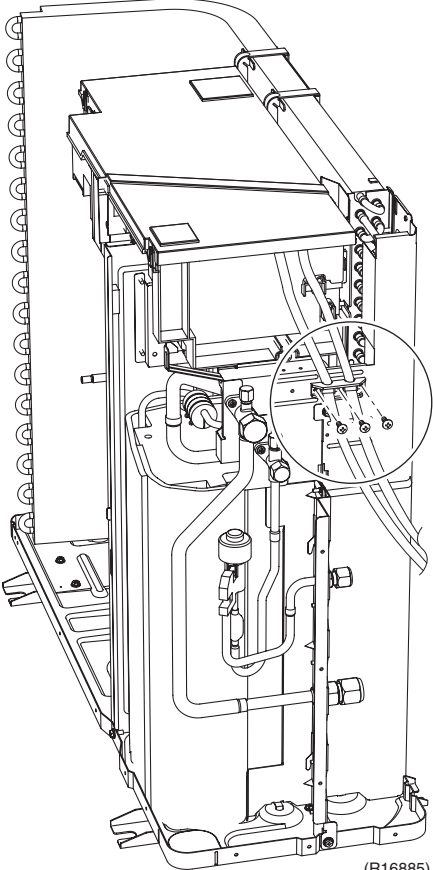
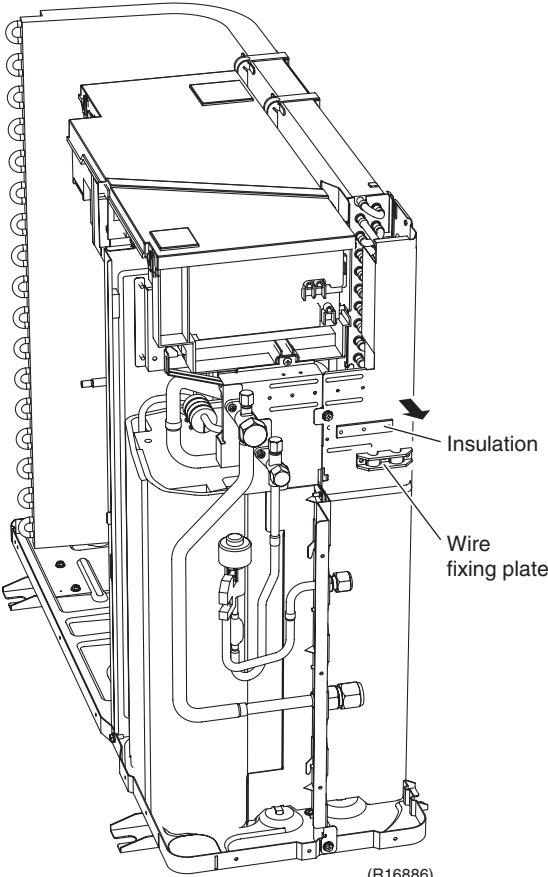
Step	Procedure	Points
3	<p>Remove the 3 screws on the wire fixing plate.</p>  <p>(R16885)</p>	
4	<p>Remove the wire fixing plate and the insulation.</p>  <p>(R16886)</p>	<ul style="list-style-type: none"> <li>■ Remove the screws of the terminal board and earth wire to disconnect the connection wires.</li> </ul>

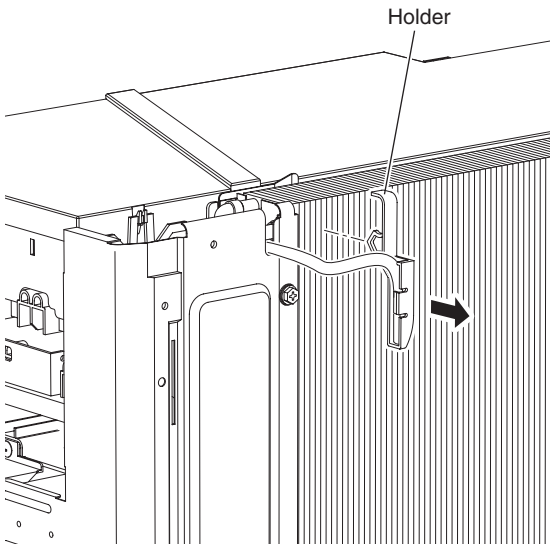
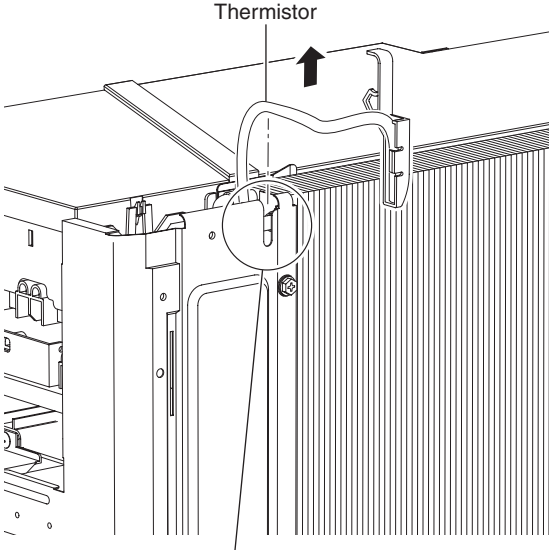
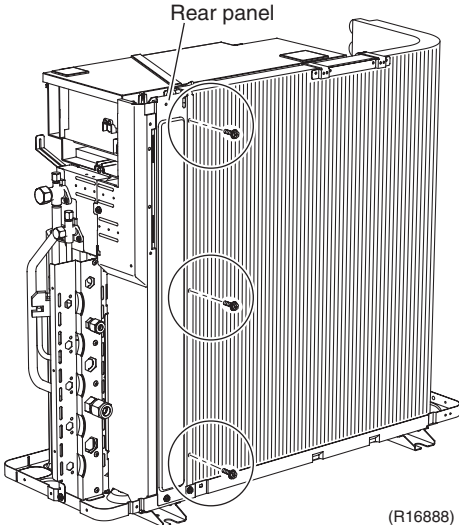
Step	Procedure	Procedure	Points
5	Release the holder of the outdoor temperature thermistor.	 <p style="text-align: right;">(R16887)</p>	<ul style="list-style-type: none"> <li>■ The holder is secured in the clearances of the outdoor heat exchanger fins.</li> </ul>
6	Release the harness of the outdoor temperature thermistor from the groove.	 <p style="text-align: right;">(R17075)</p>	
7	Remove the 3 screws on the rear panel.	 <p style="text-align: right;">(R16888)</p>	

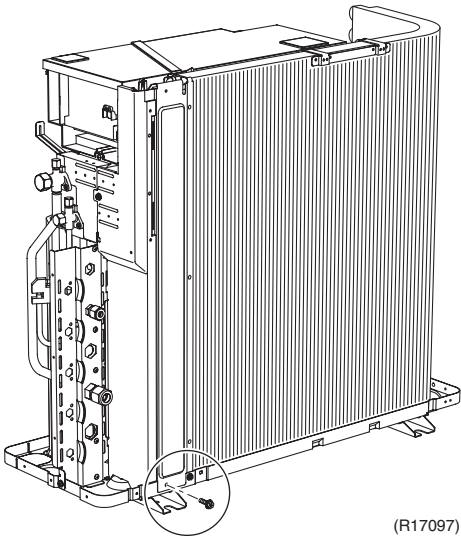
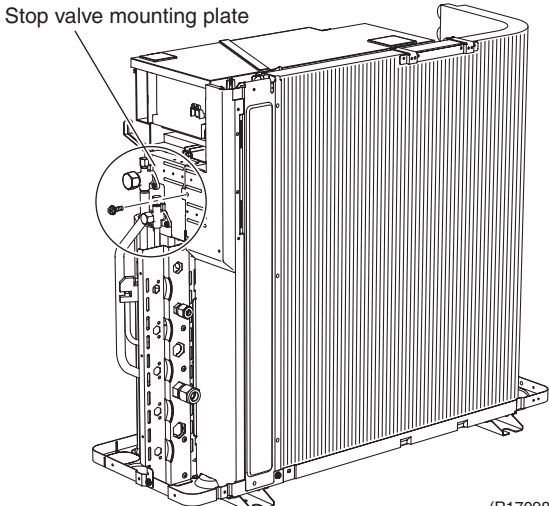
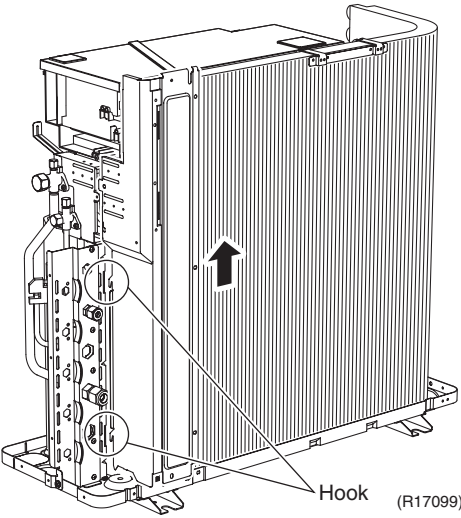
Step	Procedure	Points
8	<p>Remove the screw on the bottom frame.</p>  <p>(R17097)</p>	
9	<p>Remove the screw on the stop valve mounting plate.</p>  <p>Stop valve mounting plate</p> <p>(R17098)</p>	
10	<p>Lift the rear panel upward to unfasten the 2 hooks.</p>  <p>Hook (R17099)</p>	

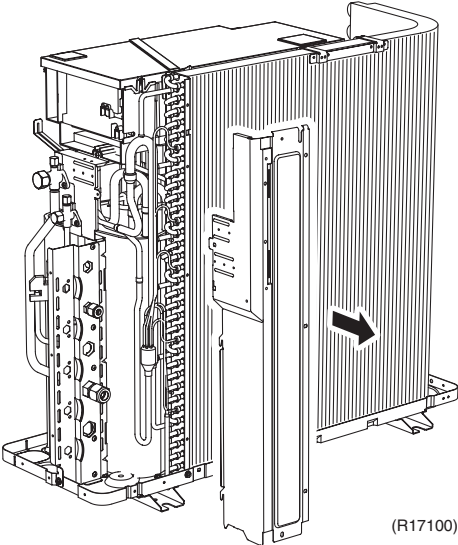
Step	Procedure	Points
11	<p data-bbox="201 219 469 255">Remove the rear panel.</p>  <p data-bbox="943 775 1011 801">(R17100)</p>	



## 2. Removal of Electrical Box

### Procedure



### Warning

Be sure to wait for 10 minutes or more after turning off all power supplies before disassembling work.

Step	Procedure	Points
1	Remove the screw on the stop valve mounting plate.	
2	Remove the screw on the partition plate (1).	
3	Remove the 2 screws to detach the earth wires.	

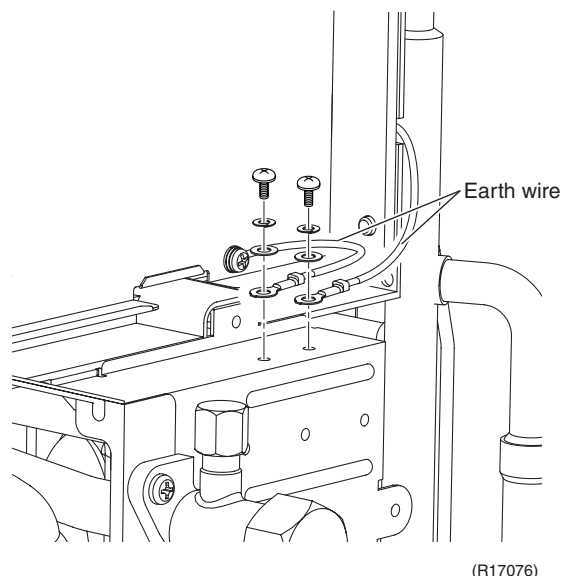
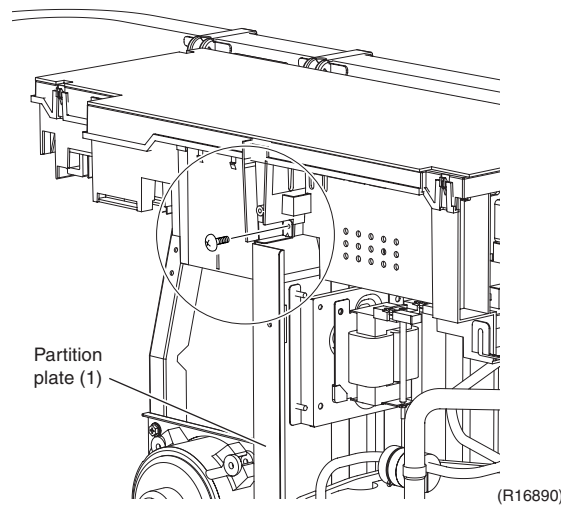
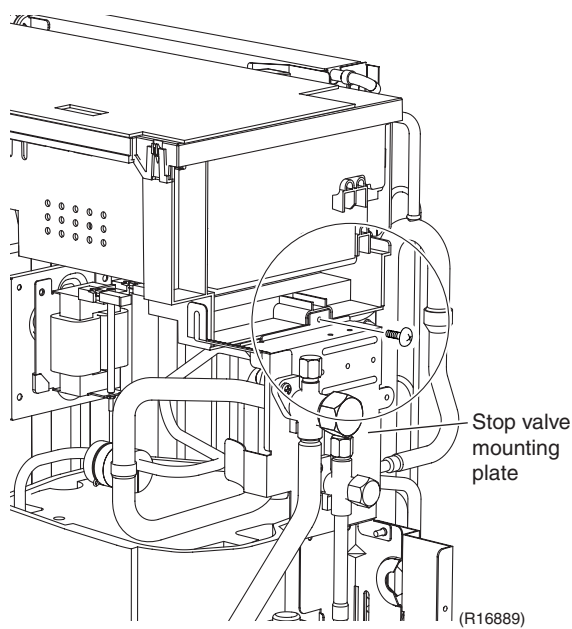

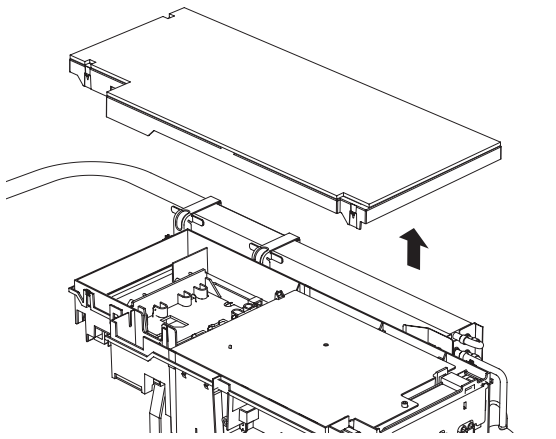
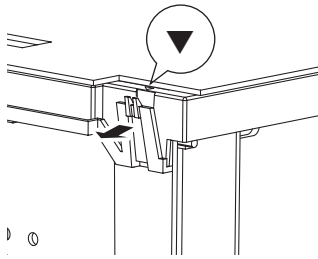
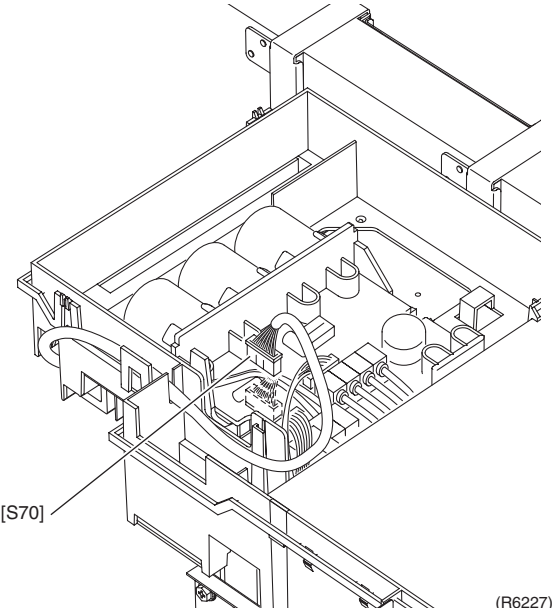
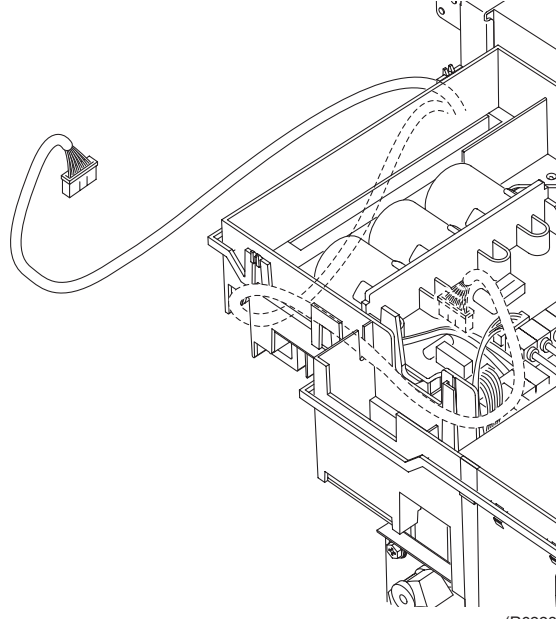
Step		Procedure	Points
4	Open the cover of the electrical box.	 <p>(R17078)</p>	<p>■ Unfasten the four hooks. The hooks are marked with ▼.</p>  <p>(R17077)</p>
5	Disconnect the fan motor connector [S70].	 <p>[S70]</p> <p>(R6227)</p>	
6	Release the fan motor lead wire.	 <p>(R6228)</p>	

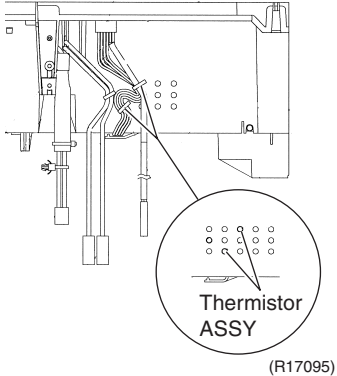
Step	Procedure	Points
7	Disconnect the connector for the electronic expansion valve coil [S20].	<ul style="list-style-type: none"> <li>When reassembling, insert the clamps of the thermistor ASSY into the hole as below.</li> </ul>
8	Disconnect the connector for the thermistors [S90].	
9	Disconnect the connector for the overload protector (OL) [S40].	

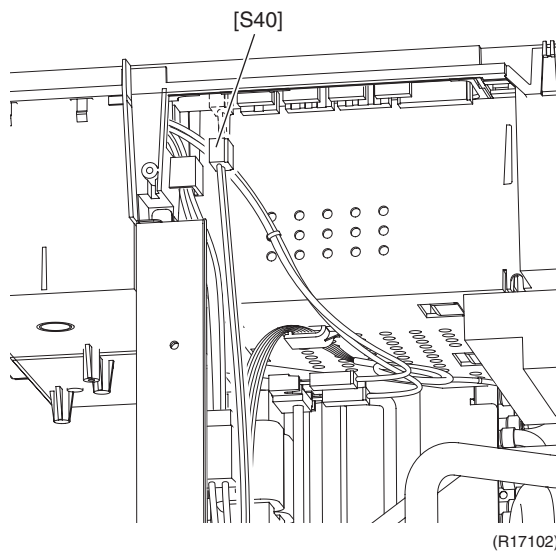
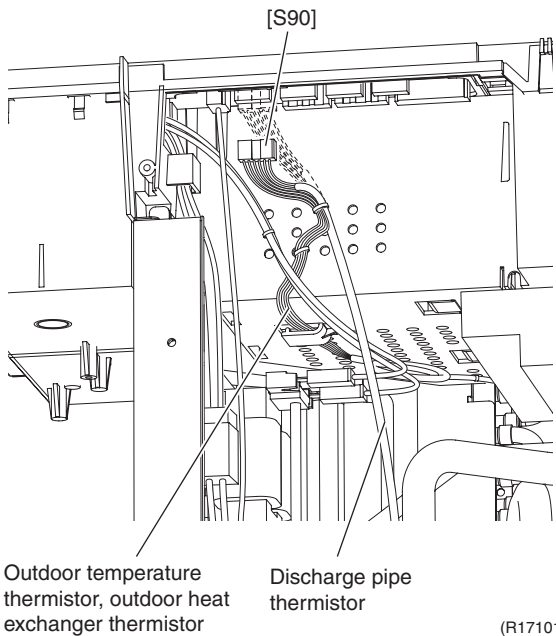
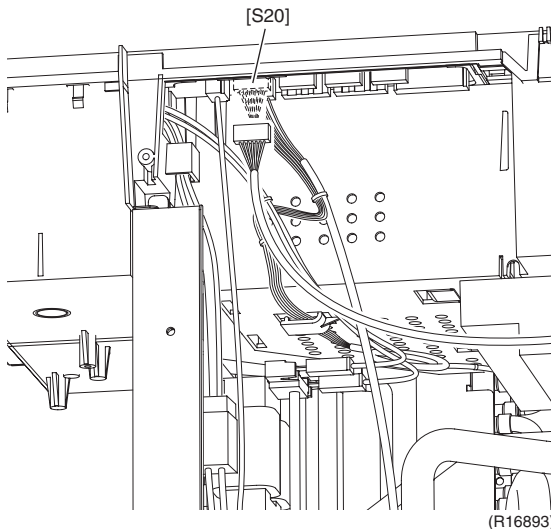

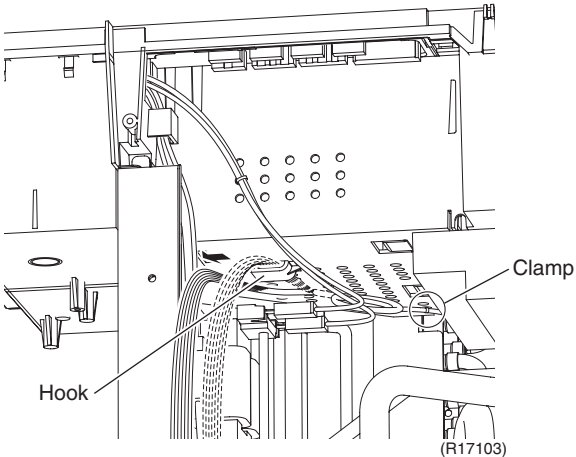
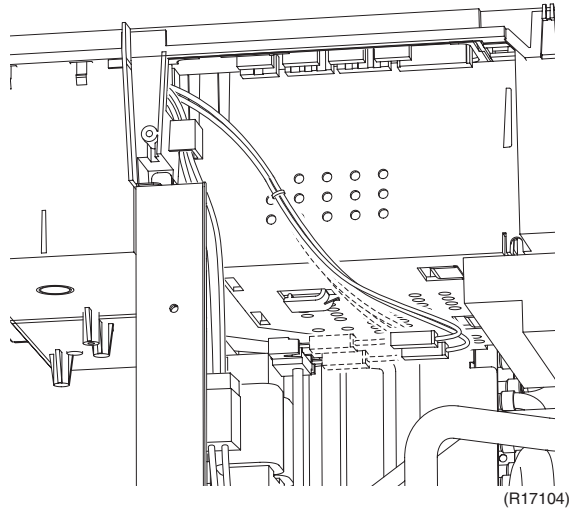
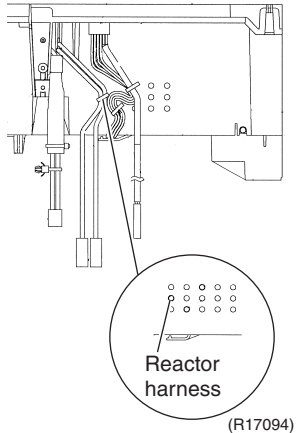
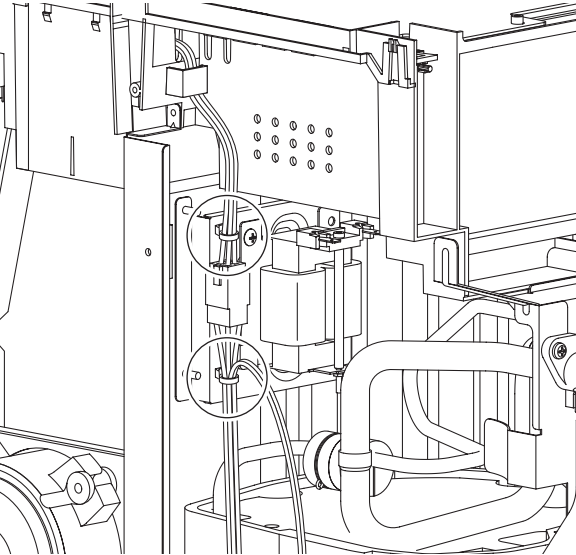
Step	Procedure	Procedure	Points
10	Release the thermistor harnesses from the hook on the bottom of the electrical box and then pull out the clamp.	 <p>(R17103)</p>	<p>■ When reassembling, insert the clamp of the reactor harness into the hole as below.</p>
11	Disconnect the 2 connectors for the reactor.	 <p>(R17104)</p>	 <p>(R17094)</p>
12	Pull out the 2 clamps to detach the OL lead wire and the compressor lead wire from the partition plate (1).	 <p>(R17105)</p>	

Step	Procedure	Points
13	Disconnect the relay connector for the compressor.	
14	Slide the electrical box to the left to unfasten the hook on the right side.	
15	Lift up the electrical box and remove it.	

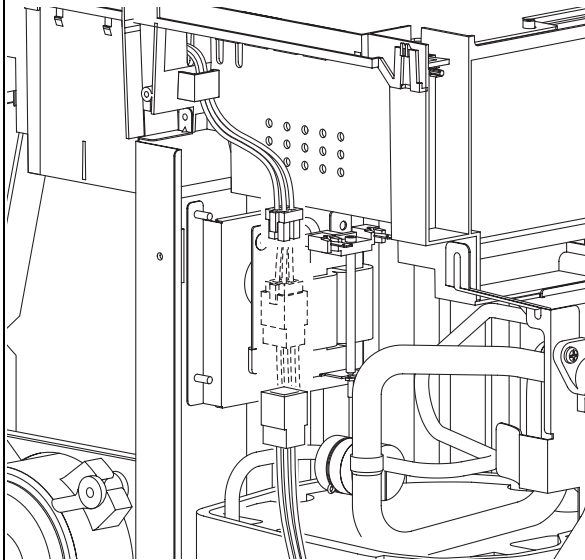

(R17106)

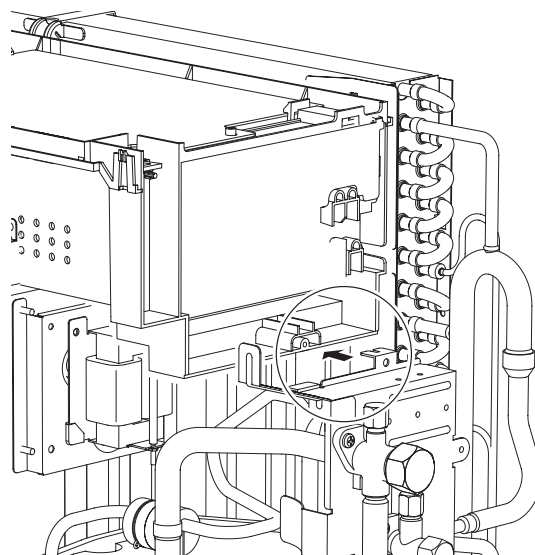

(R17107)

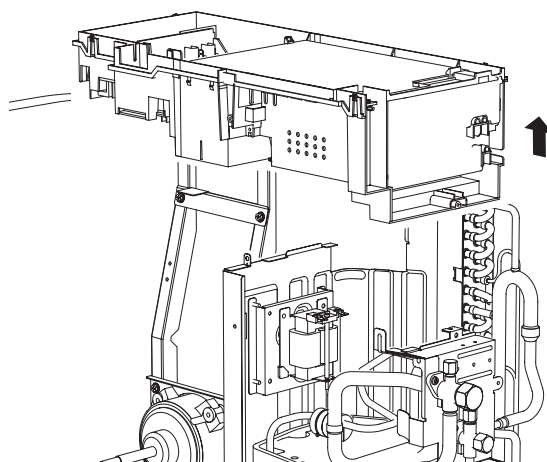

(R17108)

### 3. Removal of PCBs

**Procedure**



**Warning** Be sure to wait for 10 minutes or more after turning off all power supplies before disassembling work.

Step	Procedure	Points
1. Remove the main PCB.		
1 Remove the screw.	<p>(R6340)</p>	
2 Unfasten the 2 hooks.	<p>(R6341)</p>	
3 Lift up the main PCB.	<p>Main PCB</p> <p>(R16894)</p>	

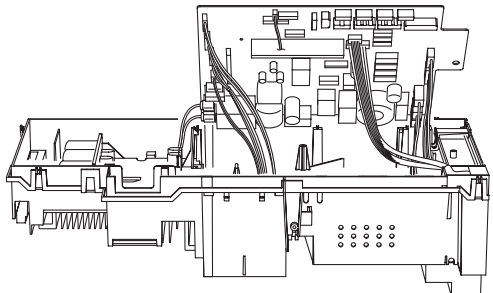
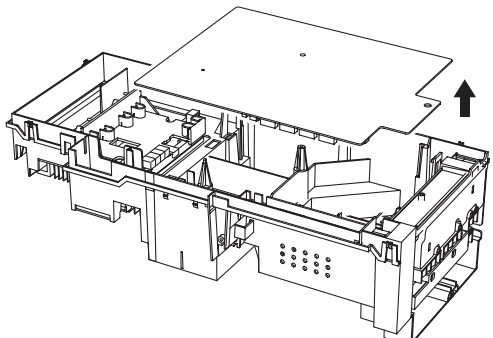
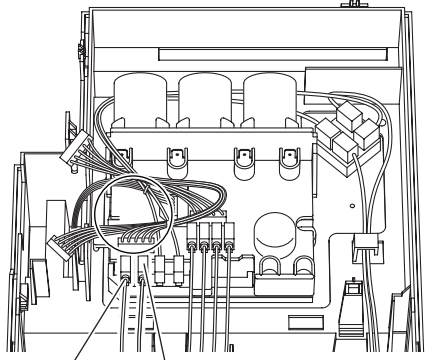
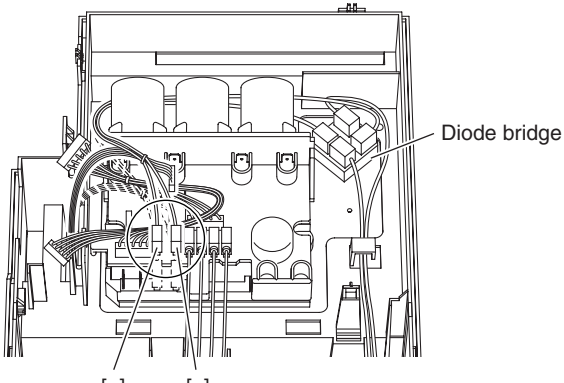
Step	Procedure	Points
4	Disconnect the connectors.	 <p>(R6343)</p>
5	Remove the main PCB.	 <p>(R6344)</p>
2. Remove the inverter PCB (MID).		
1	Disconnect the connectors for the reactor [L1] [L2].	 <p>[L2] [L1] (R17078)</p>
2	Disconnect the connectors for the diode bridge.	 <p>[+] (red) [-] (black) Diode bridge (R17079)</p>

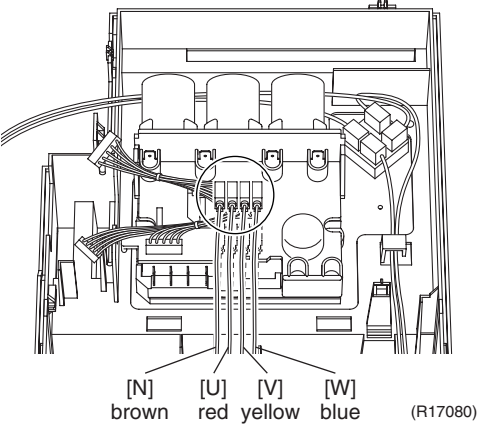
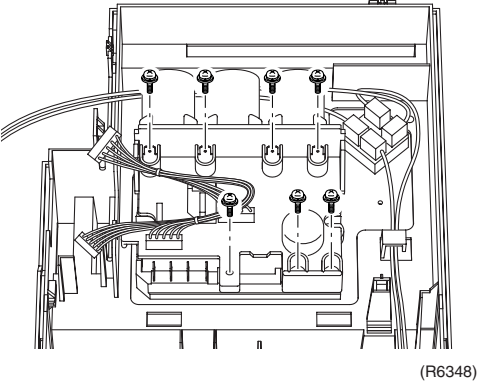
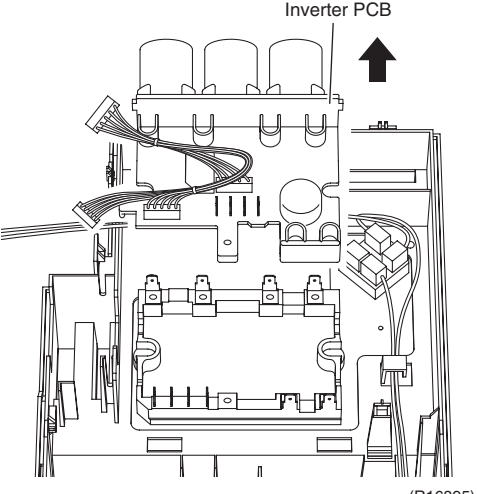
Step	Procedure	Points
3	<p>Disconnect the connectors for the compressor.</p> 	
4	<p>Remove the 7 screws.</p> 	
5	<p>Lift the inverter PCB (MID) upward and remove it.</p> 	

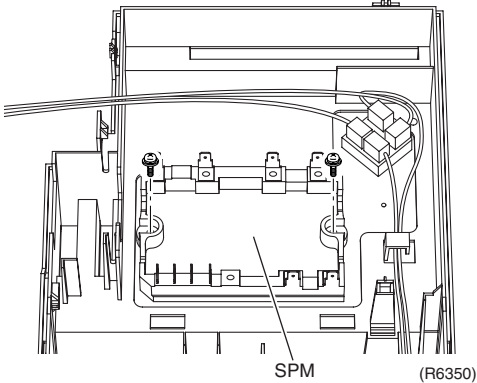
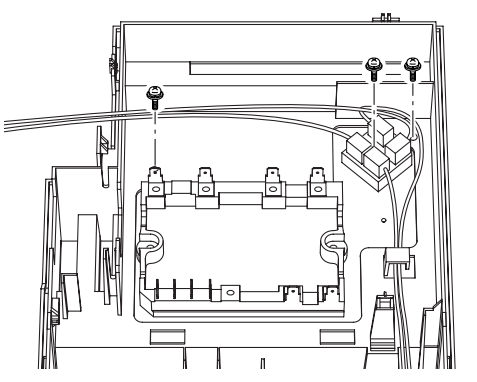
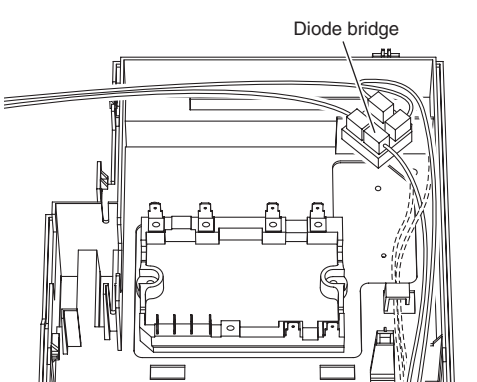
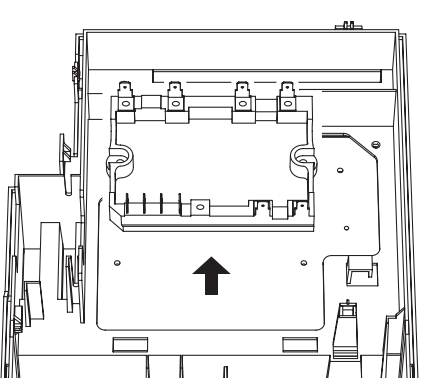

Step	Procedure	Points
3. Remove the SPM.		
1	Remove the 2 screws.  <p style="text-align: center;">SPM (R6350)</p>	
2	Remove the 3 screws.  <p style="text-align: center;">(R17082)</p>	
3	Remove the diode bridge.  <p style="text-align: center;">Diode bridge (R17083)</p>	
4	Remove the SPM.  <p style="text-align: center;">(R6354)</p>	

Step	Procedure	Points
4.	Remove the service monitor PCB.	
1	Release the harness from the hook.	
2	Disconnect the connectors [S52] [S102] from the service monitor PCB.	
3	Remove the service monitor PCB.	
4	Remove the screw of the terminal board.	

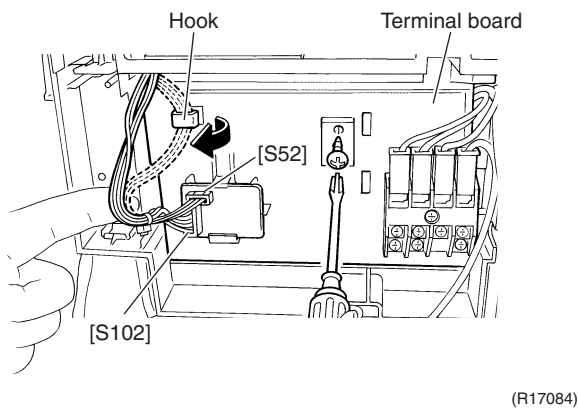

## 4. Removal of Fan Motor

### Procedure



### Warning

Be sure to wait for 10 minutes or more after turning off all power supplies before disassembling work.

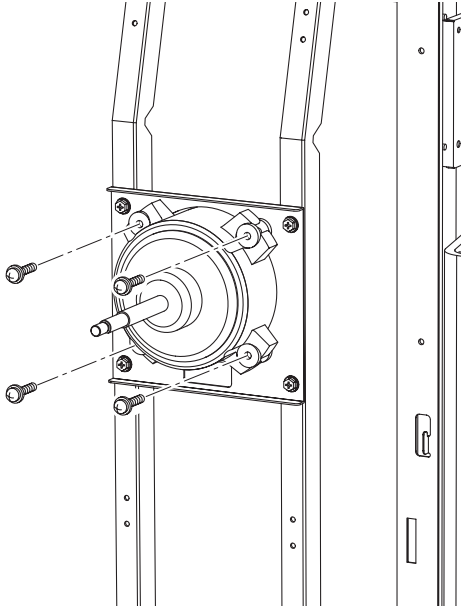
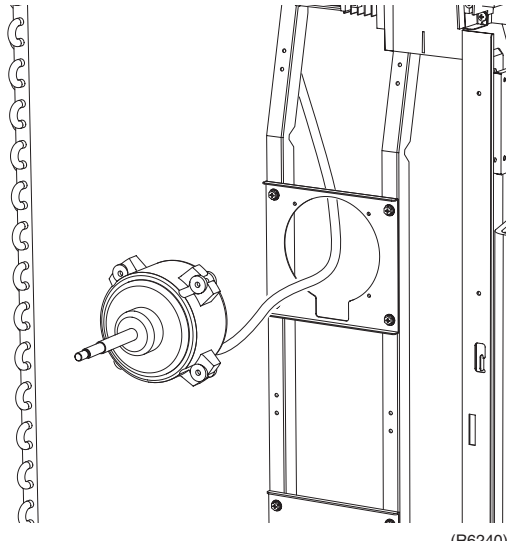
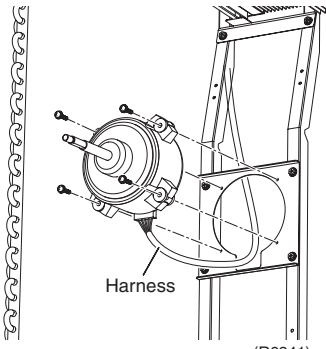
Step	Procedure	Procedure	Points
1 2	1 Remove the 2 lower screws first. 2 Then, remove the 2 top screws.	 <p style="text-align: right;">(R6239)</p>	<ul style="list-style-type: none"> <li>■ Be sure to remove the lower screws first. If the top screws are removed first, the fan motor may tilt down or fall and cause injury because its center of gravity is shifted to the front.</li> </ul>
3	Remove the fan motor.	 <p style="text-align: right;">(R6240)</p>	<ul style="list-style-type: none"> <li>■ When reassembling, make sure that the wire harness is facing downward.</li> </ul>  <p style="text-align: right;">(R6241)</p>

# 5. Removal of Electronic Expansion Valve Coil / Thermistors

**Procedure**

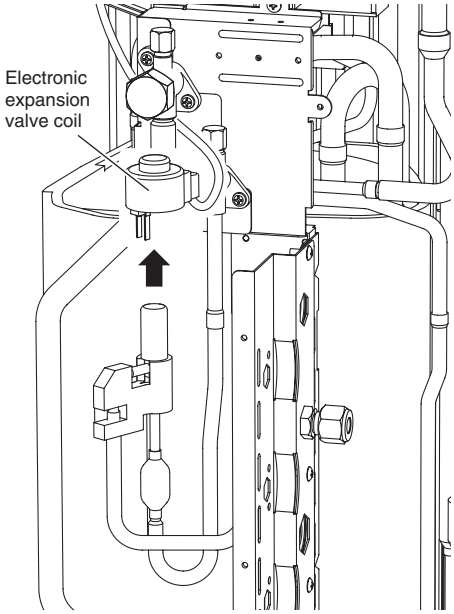
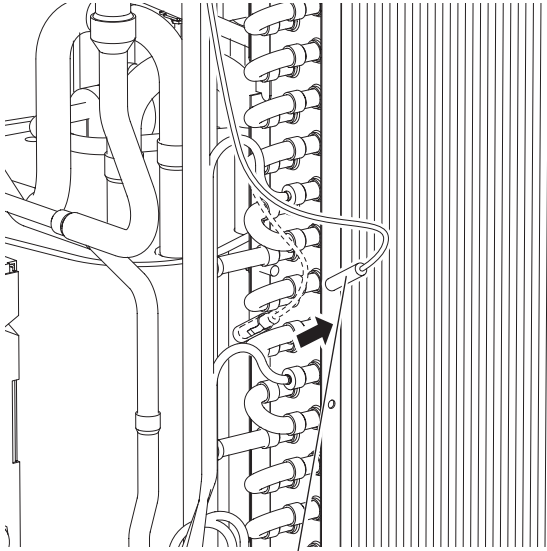
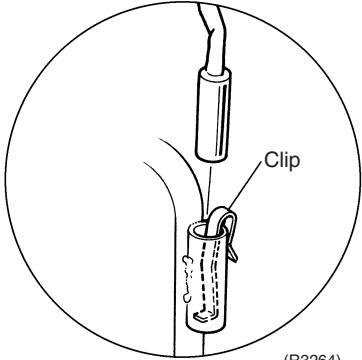

**Warning** Be sure to wait for 10 minutes or more after turning off all power supplies before disassembling work.

Step	Procedure	Points
<p>1. Remove the electronic expansion valve coil.</p>	 <p style="text-align: right;">(R16896)</p>	
<p>2. Remove the thermistors.</p> <p>1 Pull out the outdoor heat exchanger thermistor.</p>	 <p style="text-align: right;">(R16897)</p>	<p>■ Be careful not to lose the clip for the thermistor.</p>  <p style="text-align: right;">(R3264)</p>

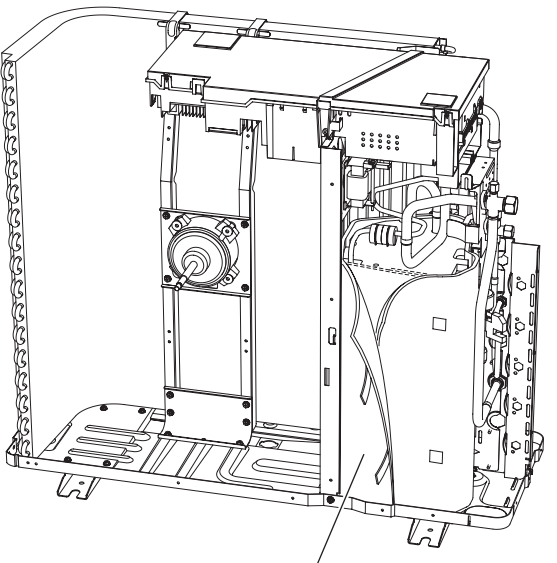
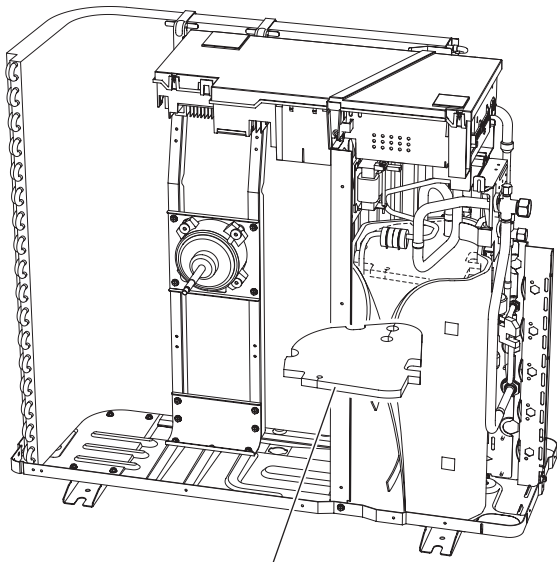
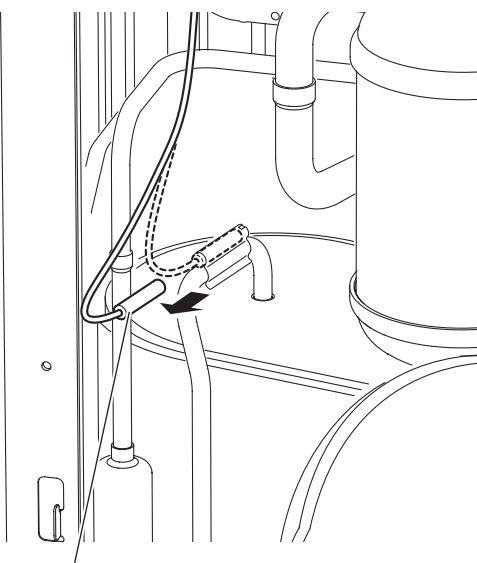
Step	Procedure	Procedure	Points
2	Slightly open the sound blanket (outer).	 <p style="text-align: center;">Sound blanket (outer) (R16898)</p>	
3	Remove the sound blanket (top upper).	 <p style="text-align: center;">Sound blanket (top upper) (R16899)</p>	
4	Remove the discharge pipe thermistor.	 <p style="text-align: center;">Discharge pipe thermistor (R9469)</p>	<p>■ Be careful not to lose the fixture.</p>

# 6. Removal of Reactor

**Procedure**



**Warning** Be sure to wait for 10 minutes or more after turning off all power supplies before disassembling work.

Step	Procedure	Points
1	Remove the screw.	
2	Lift the reactor to unfasten the hooks, and remove the reactor.	

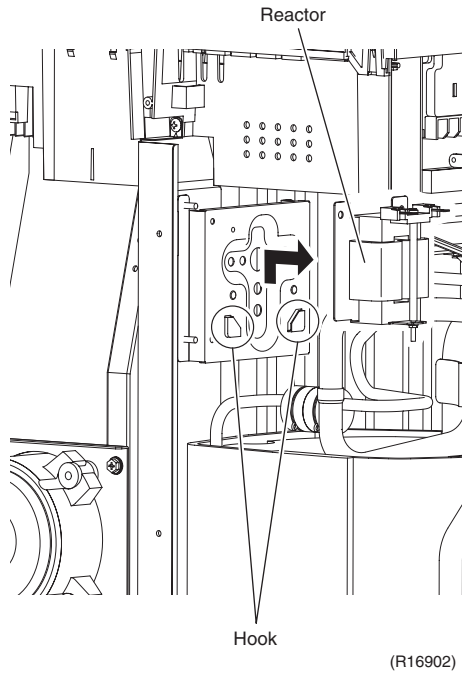
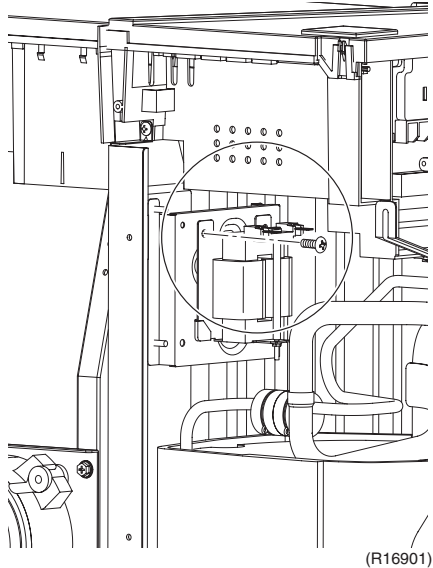

## 7. Removal of Sound Blankets

### Procedure

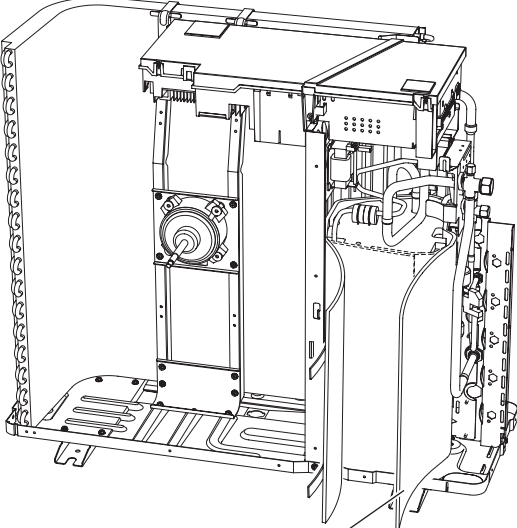
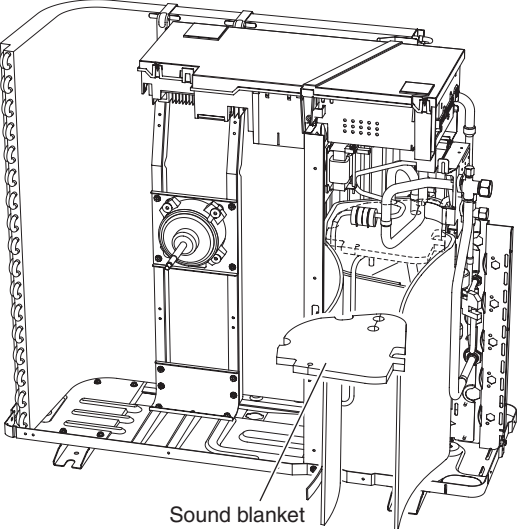
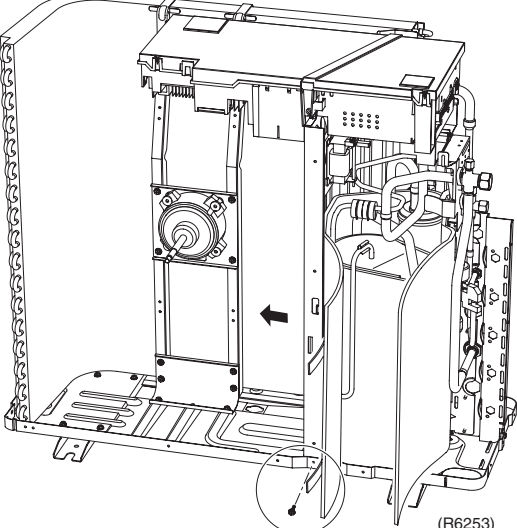

**Warning** Be sure to wait for 10 minutes or more after turning off all power supplies before disassembling work.

Step	Procedure	Points
1	<p>Open the sound blanket (outer).</p>  <p style="text-align: center;">Sound blanket (outer) (R17085)</p>	
2	<p>Remove the sound blanket (top upper).</p>  <p style="text-align: center;">Sound blanket (top upper) (R17086)</p>	<p>■ The sound blanket is fragile. Carefully pass the discharge pipe through it.</p>
3	<p>Remove the screw and slightly push the partition plate (1) to the left for easy work.</p>  <p style="text-align: center;">(R6253)</p>	

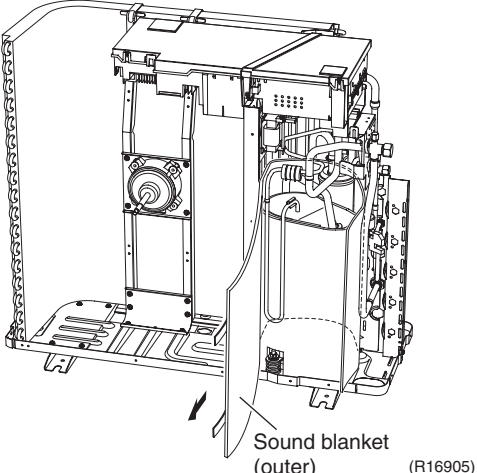
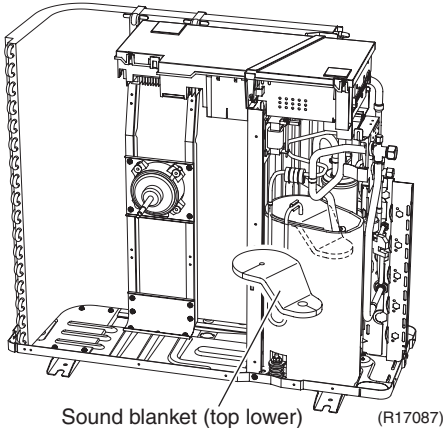
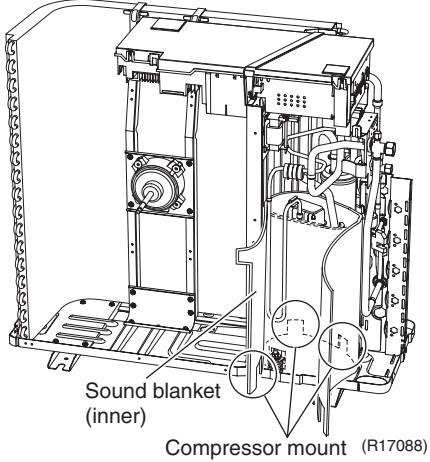
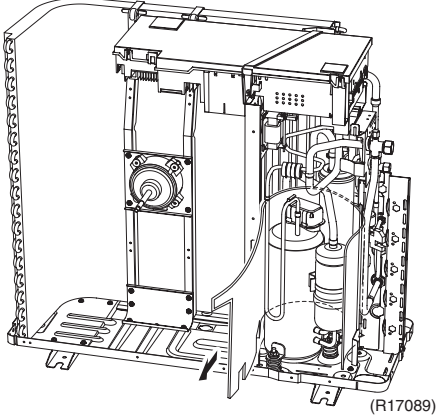
Step	Procedure	Points
4	<p>Remove the sound blanket (outer).</p>  <p>Sound blanket (outer) (R16905)</p>	
5	<p>Remove the sound blanket (top lower).</p>  <p>Sound blanket (top lower) (R17087)</p>	<ul style="list-style-type: none"> <li>■ The sound blanket is fragile. Carefully pass the discharge pipe through it.</li> </ul>
6	<p>Open the sound blanket (inner).</p>  <p>Sound blanket (inner) Compressor mount (R17088)</p>	<ul style="list-style-type: none"> <li>■ The sound blanket is fragile. Be careful of the notches of the compressor mount (3 locations).</li> </ul>
7	<p>Remove the sound blanket (inner).</p>  <p>(R17089)</p>	



## 8. Removal of Compressor

### Procedure



### Warning

Be sure to wait for 10 minutes or more after turning off all power supplies before disassembling work.

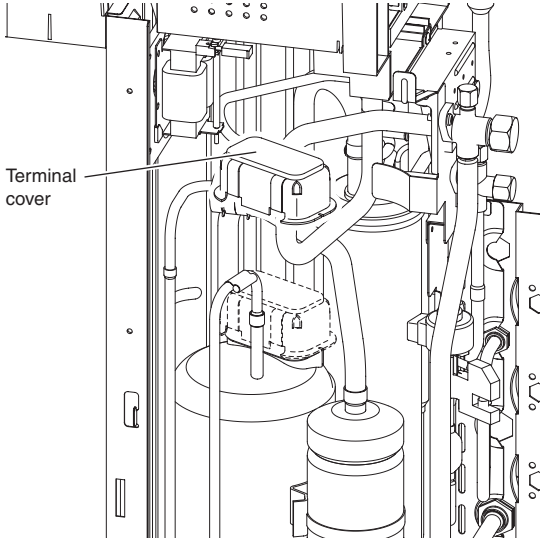
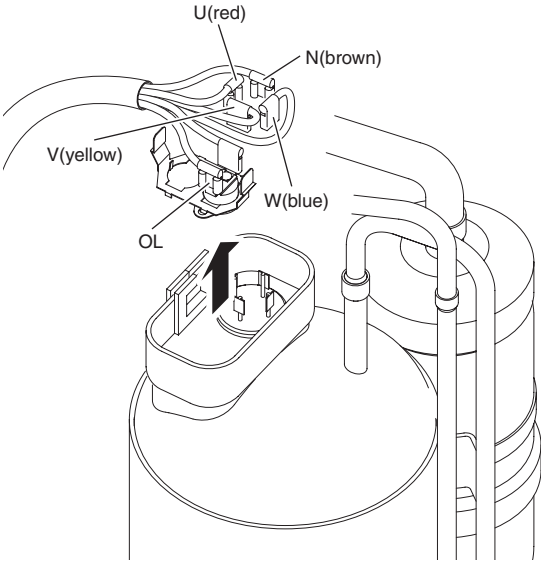
Step	Procedure	Points
1	<p>Remove the terminal cover.</p>  <p>(R16907)</p>	
2	<p>Pull out the 4 lead wires.</p>	
3	<p>Remove the overload protector (OL).</p>  <p>(R6259)</p>	

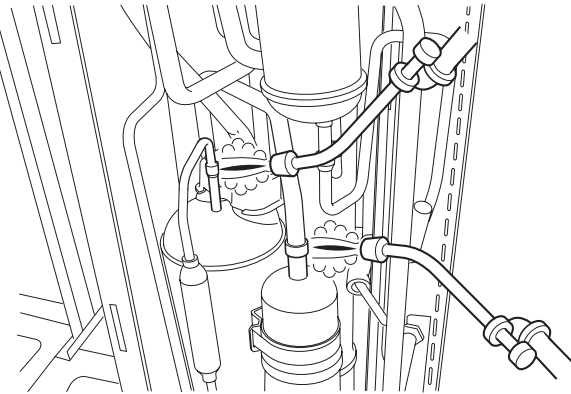
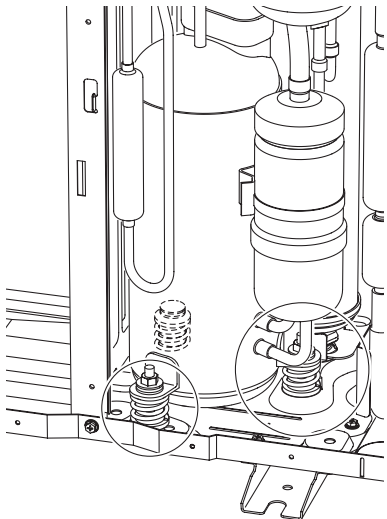
Step	Procedure	Points
<ul style="list-style-type: none"> <li>■ Before working, make sure that the refrigerant gas is empty in the circuit.</li> <li>■ Be sure to apply nitrogen replacement when heating up the brazed part.</li> </ul>	 <p style="text-align: right;">(R9646)</p>	<p><b>Warning</b> Be careful not to get yourself burnt with the pipes and other parts that are heated by the gas brazing machine.</p>
4	Heat up the brazed part and withdraw the piping with pliers.	<p><b>Warning</b> If the refrigerant gas leaks during work, ventilate the room. (If the refrigerant gas is exposed to flames, toxic gas may be generated.)</p>
5	Remove the 2 nuts.	<p><b>Warning</b> Since it may happen that the refrigerant oil in the compressor catches fire, prepare wet cloth so as to extinguish fire immediately.</p> <p><b>Caution</b> From the viewpoint of global environment protection, do not discharge the refrigerant gas in the atmosphere. Make sure to collect all the refrigerant gas.</p> <p><b>Cautions for restoration</b></p> <ol style="list-style-type: none"> <li>1. Restore the piping by non-oxidation brazing.</li> <li>2. It is required to prevent the carbonization of the oil inside the four way valve and the deterioration of the gaskets affected by heat. (Keep below 120°C.) For the sake of this, wrap the four way valve with wet cloth and provide water so that the cloth does not dry.</li> </ol> <p><b>In case of difficulty with gas brazing machine</b></p> <ol style="list-style-type: none"> <li>1. Disconnect the brazed part where is easy to disconnect and restore.</li> <li>2. Cut pipes on the main unit with a tube cutter in order to make it easy to disconnect.</li> </ol>
<p><b>Note:</b></p> <ul style="list-style-type: none"> <li>■ Do not use a metal saw for cutting pipes by all means because the sawdust comes into the circuit.</li> <li>■ When withdrawing the pipes, be careful not to pinch them firmly with pliers. The pipes may get deformed.</li> <li>■ Provide a protective sheet or a steel plate so that the brazing flame cannot influence peripheries.</li> <li>■ Be careful so as not to burn the compressor terminals, the name plate, the heat exchanger fin.</li> </ul>	 <p style="text-align: right;">(R9472)</p>	

# Revision History

Month / Year	Version	Revised contents
08/2012	Si001168	First edition

Warning



- Daikin products are manufactured for export to numerous countries throughout the world. Prior to purchase, please confirm with your local authorised importer, distributor and/or retailer whether this product conforms to the applicable standards, and is suitable for use, in the region where the product will be used. This statement does not purport to exclude, restrict or modify the application of any local legislation.
- Ask a qualified installer or contractor to install this product. Do not try to install the product yourself. Improper installation can result in water or refrigerant leakage, electrical shock, fire or explosion.
- Use only those parts and accessories supplied or specified by Daikin. Ask a qualified installer or contractor to install those parts and accessories. Use of unauthorised parts and accessories or improper installation of parts and accessories can result in water or refrigerant leakage, electrical shock, fire or explosion.
- Read the User's Manual carefully before using this product. The User's Manual provides important safety instructions and warnings. Be sure to follow these instructions and warnings.

If you have any enquiries, please contact your local importer, distributor and/or retailer.

### Cautions on product corrosion

1. Air conditioners should not be installed in areas where corrosive gases, such as acid gas or alkaline gas, are produced.
2. If the outdoor unit is to be installed close to the sea shore, direct exposure to the sea breeze should be avoided. If you need to install the outdoor unit close to the sea shore, contact your local distributor.

### Dealer

### **DAIKIN INDUSTRIES, LTD.**

Head Office:  
Umeda Center Bldg., 2-4-12, Nakazaki-Nishi,  
Kita-ku, Osaka, 530-8323 Japan

Tokyo Office:  
JR Shinagawa East Bldg., 2-18-1, Konan,  
Minato-ku, Tokyo, 108-0075 Japan

[http://www.daikin.com/global\\_ac/](http://www.daikin.com/global_ac/)

©All rights reserved