

REMOVAL PROCEDURE



SERVICE
MANUAL

S E R V I C E M A N U A L

6.0/7.1/8.0/9.0 kW Class

-  Outdoor Unit
-  Inverter
-  Pair Type



Service Manual Removal Procedure

Outdoor Unit

Applicable Models

●Cooling Only

RKS71KVMA

RKS71KAVMA

●Heat Pump

RXS60HAVMA

RXS71HAVMA

RXS71KVMA

RXS80KVMA

RXS90KVMA

RXS71KAVMA

RXS80KAVMA

RXS90KAVMA

Table of Contents

1. Removal of Outer Panels	2
2. Removal of Electrical Box	15
3. Removal of PCBs	19
4. Removal of Fan Motor.....	22
5. Removal of Coils / Thermistors	23
6. Removal of Sound Blankets.....	26
7. Removal of Compressor	29



Note:

- The illustrations may be slightly different depending on the model.
- The illustrations are for heat pump models as representative.

1. Removal of Outer Panels

Procedure

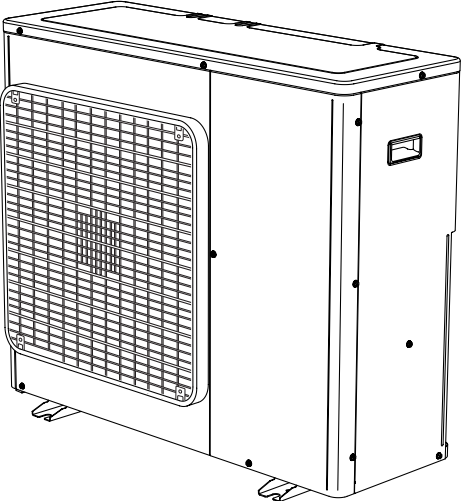
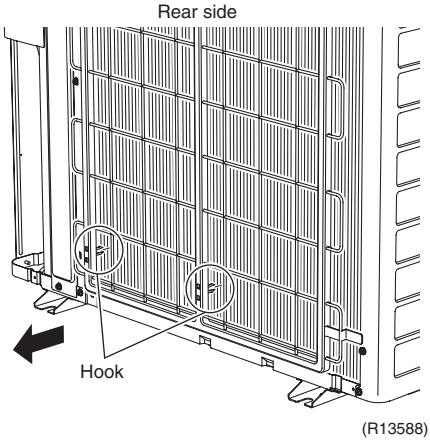

Warning Be sure to wait for 10 minutes or more after turning off all power supplies before disassembling work.

Step	Procedure	Points
1. Features	 <p style="text-align: right;">(R9036)</p>	
2. Remove the suction grille.	<p style="text-align: center;">Rear side</p>  <p style="text-align: right;">(R13588)</p>	<p>■ The hooks are secured in the clearances of the outdoor heat exchanger fins.</p>
1	Unfasten the 2 hooks at the bottom first.	

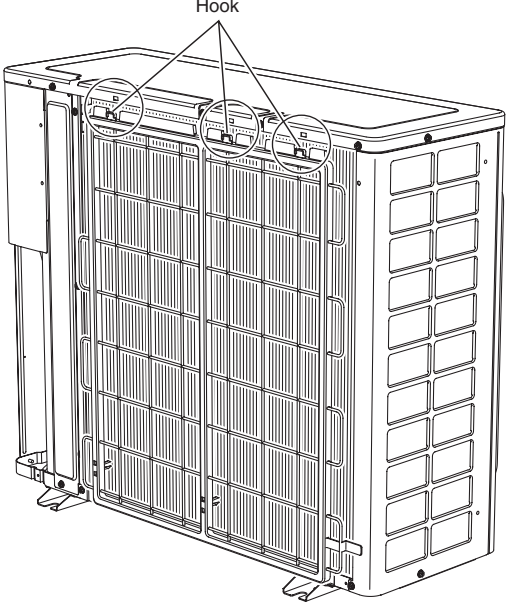
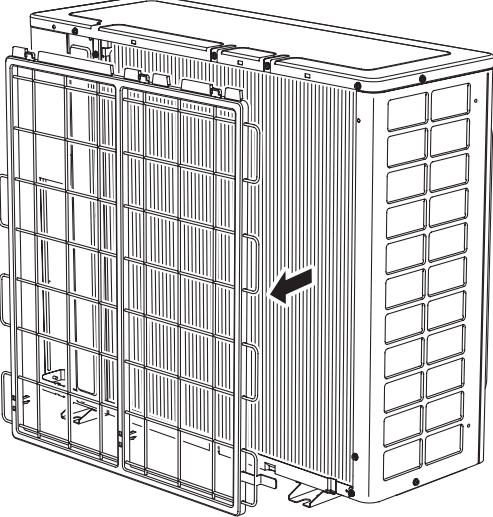
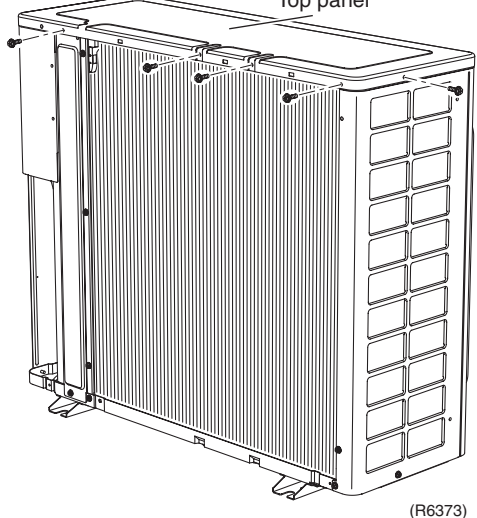
Step	Procedure	Points
2	<p data-bbox="199 219 454 309">Slide the suction grille downward to unfasten the 3 top hooks.</p>  <p data-bbox="965 869 1037 896">(R13589)</p>	
3	<p data-bbox="199 900 422 958">Remove the suction grille.</p>  <p data-bbox="965 1451 1021 1478">(R6372)</p>	
3.	<p data-bbox="199 1482 438 1518">Remove the top panel.</p> <p data-bbox="199 1527 454 1617">1 Remove the 4 screws on the back and the screw on the left side.</p>  <p data-bbox="805 1527 901 1554">Top panel</p> <p data-bbox="949 2042 1005 2069">(R6373)</p>	

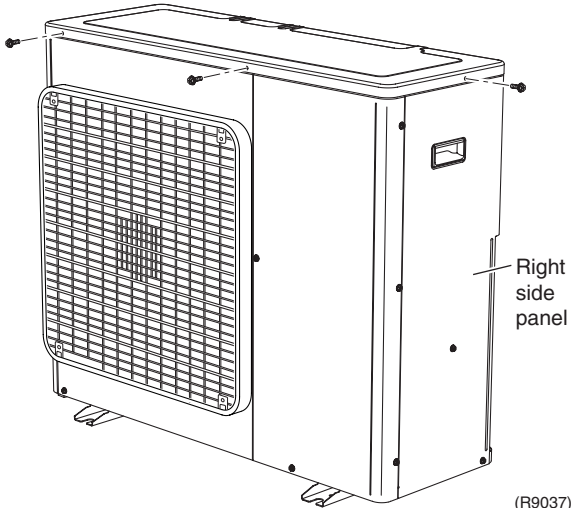
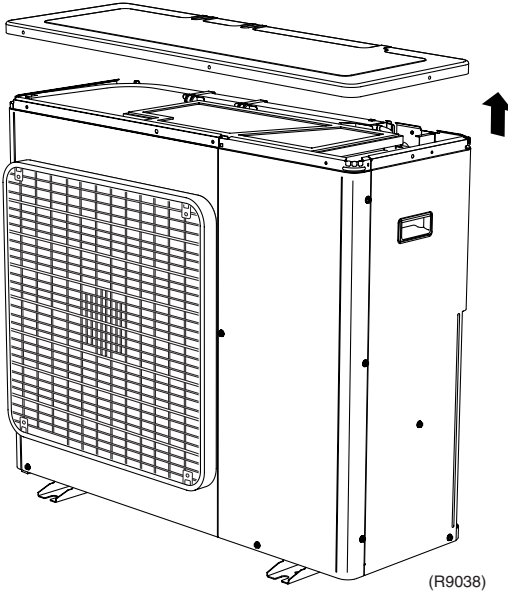
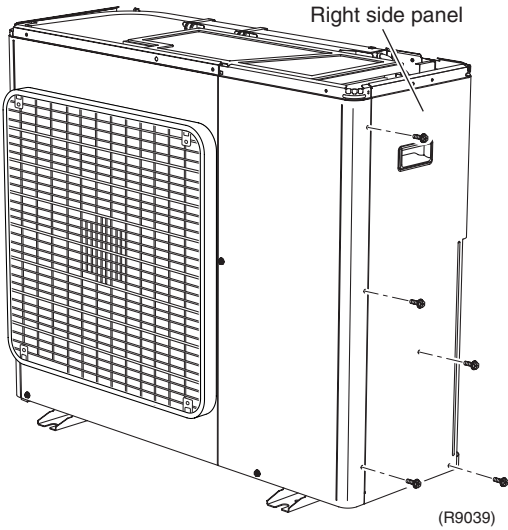
Step	Procedure	Points
2	<p>Remove the 2 screws on the front and the screw on the right side panel.</p>  <p>Right side panel</p> <p>(R9037)</p>	
3	<p>Lift the top panel and remove it.</p>  <p>(R9038)</p>	
4.	<p>Remove the right side panel.</p>	
1	<p>Remove the 5 screws.</p>  <p>Right side panel</p> <p>(R9039)</p>	

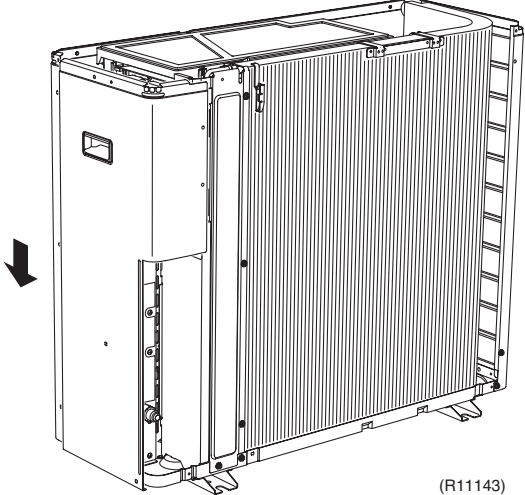
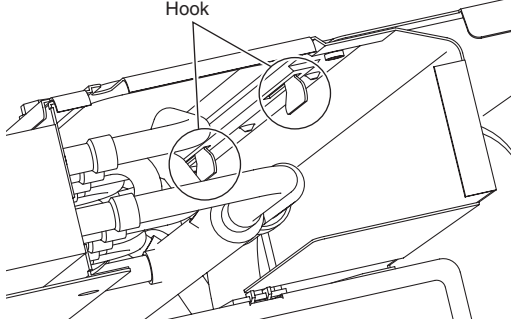
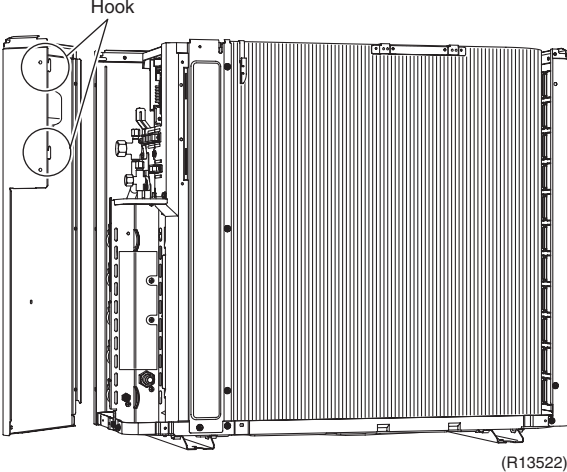
Step	Procedure	Points
2	<p data-bbox="199 217 467 338">Slide the right side panel downward to unfasten the 2 hooks on the rear side.</p>  <p data-bbox="957 739 1029 761">(R11143)</p>  <p data-bbox="973 1153 1045 1176">(R13521)</p>  <p data-bbox="997 1680 1069 1702">(R13522)</p>	

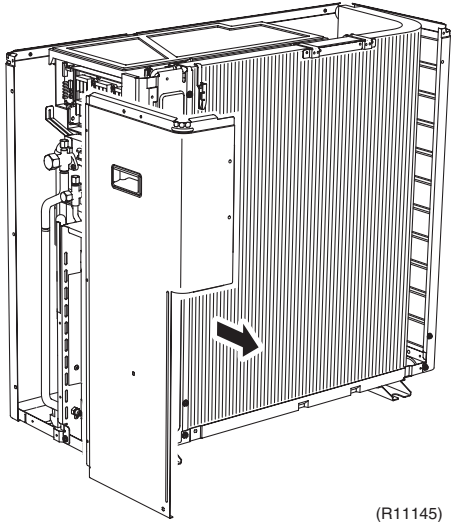
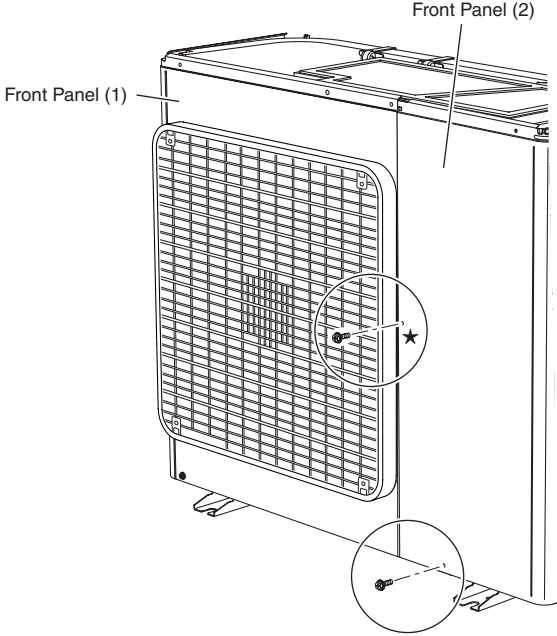
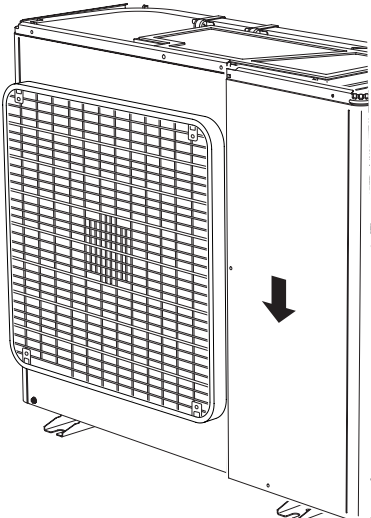
Step	Procedure	Points
3	<p>Remove the right side panel.</p>  <p>(R11145)</p>	
5.	<p>Remove the front panel (2).</p> <p>1 Remove the 2 screws.</p>  <p>(R9042)</p> <p>2 Slide the front panel (2) downward to unfasten the hook.</p>  <p>(R9043)</p>	<p>★: This screw is M5(3) × 16</p>

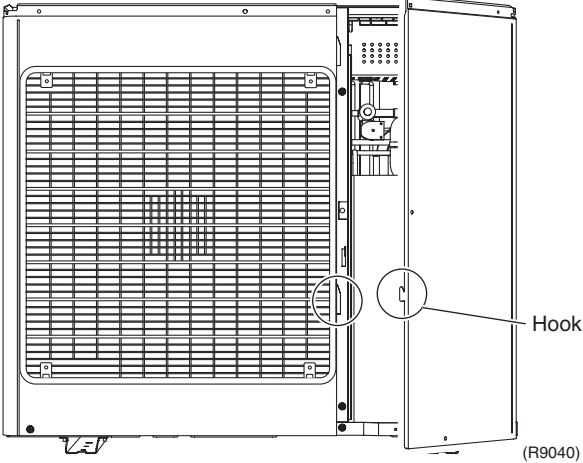
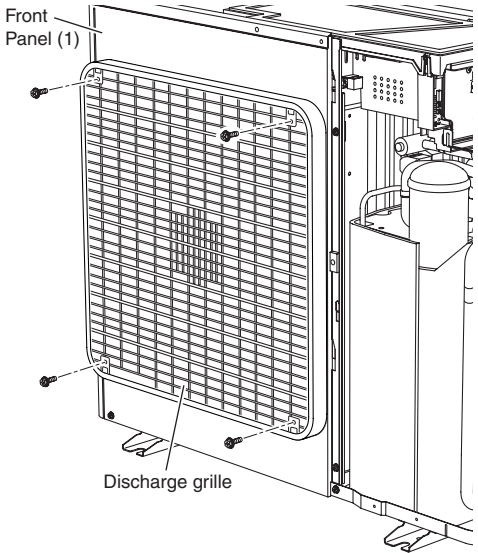
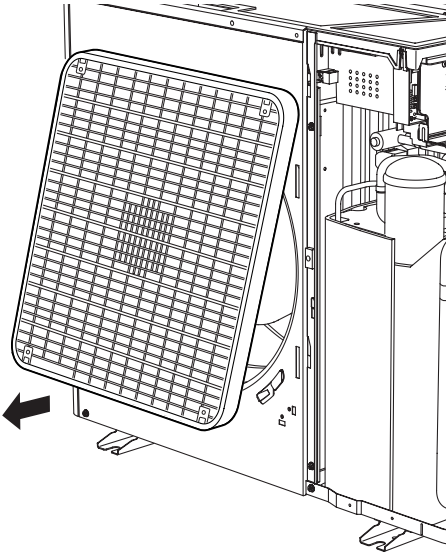
Step	Procedure	Points
3	Remove the front panel (2). 	
6.	Remove the front panel (1). 1 Remove the 4 screws on the discharge grille.  2 Pull the bottom of the discharge grille. 	<ul style="list-style-type: none"> ■ Remove the discharge grille and the outdoor fan first to remove the front panel (1).

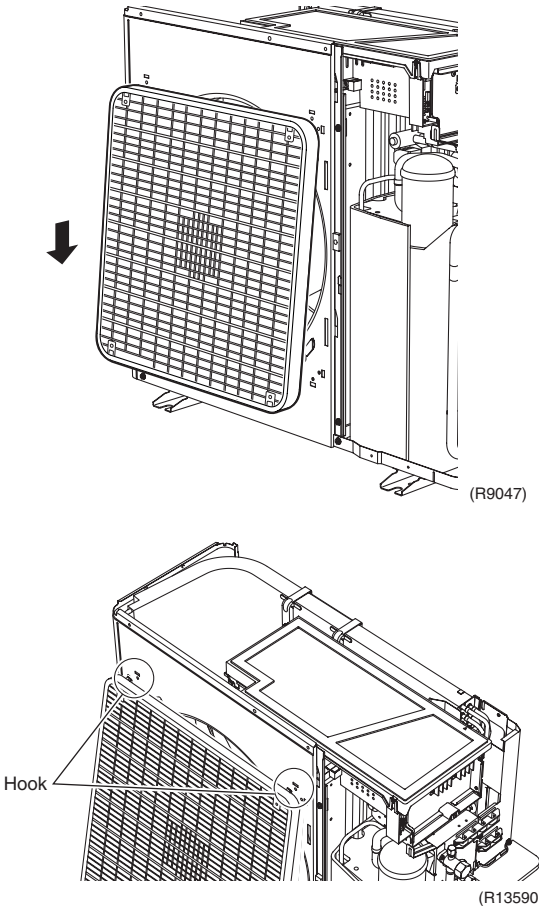
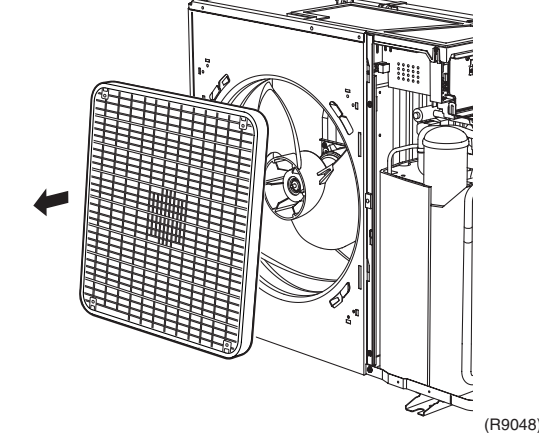
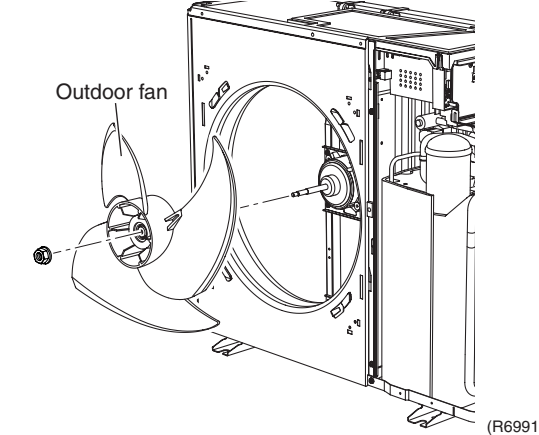
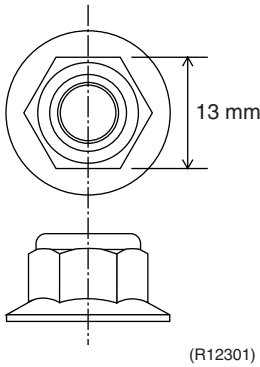
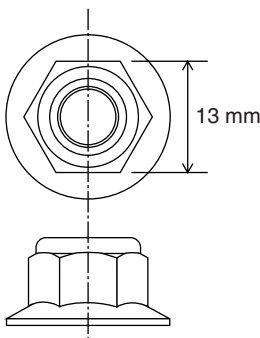
Step	Procedure	Points
3	<p>Slide the discharge grille downward to unfasten the 2 hooks at the top.</p>  <p>(R9047)</p>  <p>(R13590)</p>	
4	<p>Remove the discharge grille.</p>  <p>(R9048)</p>	
5	<p>Remove the nut of the outdoor fan.</p>  <p>(R6991)</p>	<p>■ Nut size : M8</p>  <p>13 mm</p> <p>(R12301)</p>

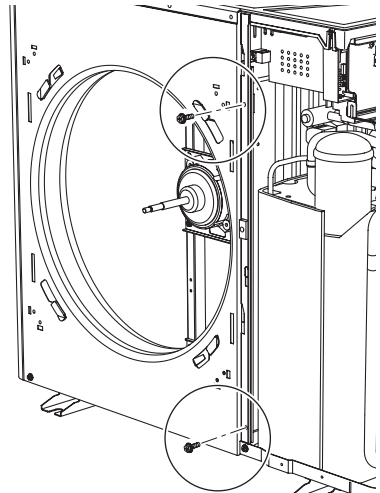
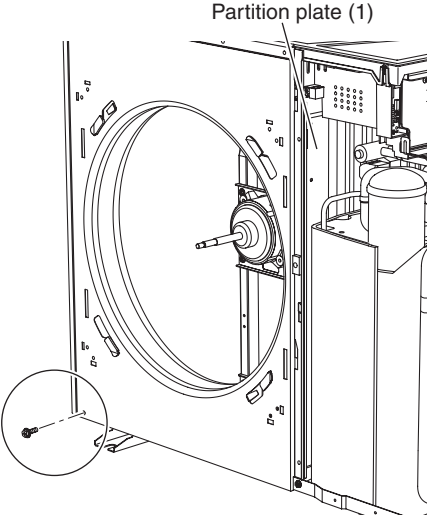
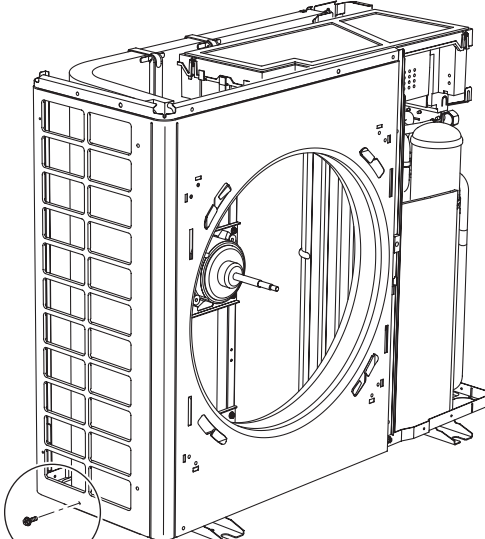
Step	Procedure	Points
6	Remove the 2 screws on the partition plate (1).	
	 <p>(R6992)</p>	
7	Remove the screw at the bottom left of the front.	
	 <p>Partition plate (1)</p> <p>(R6993)</p>	
8	Remove the screw at the bottom of the left side.	
	 <p>(R6393)</p>	

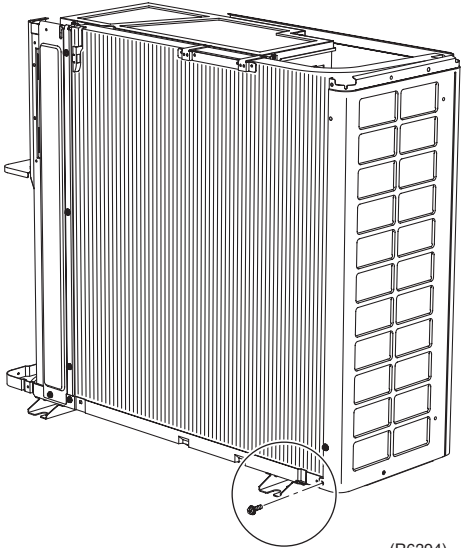
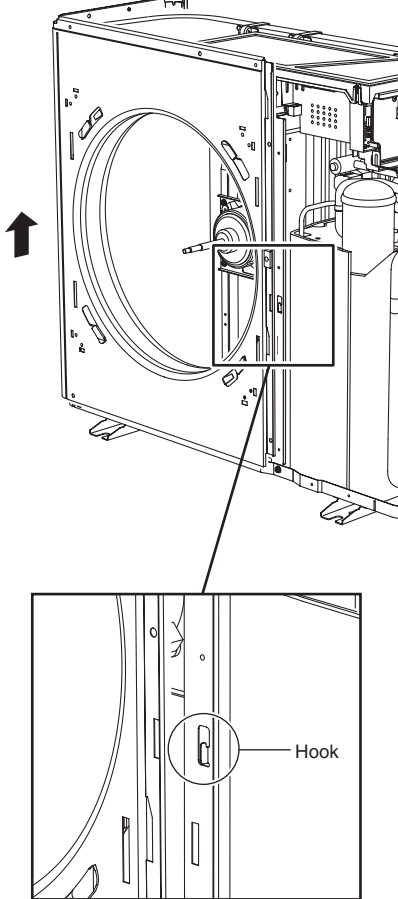
Step		Procedure	Points
9	Remove the screw at the bottom of the rear side.	 <p>(R6394)</p>	
10	Lift the front panel (1).	 <p>(R6994)</p>	<ul style="list-style-type: none"> ■ The front panel (1) has a hook on its front.

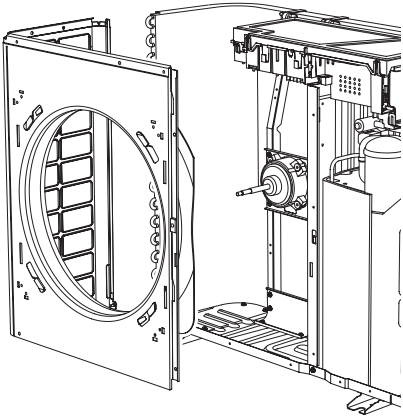
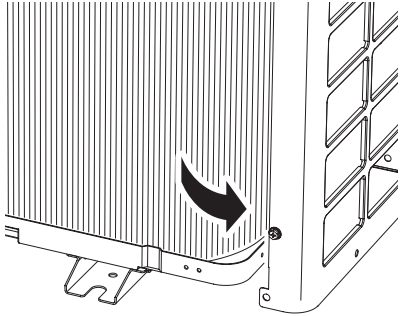
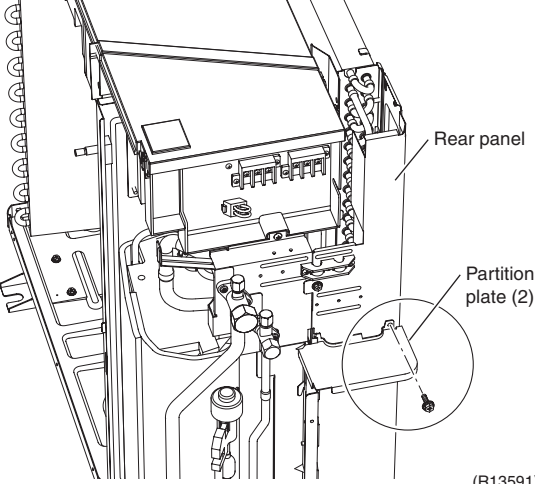
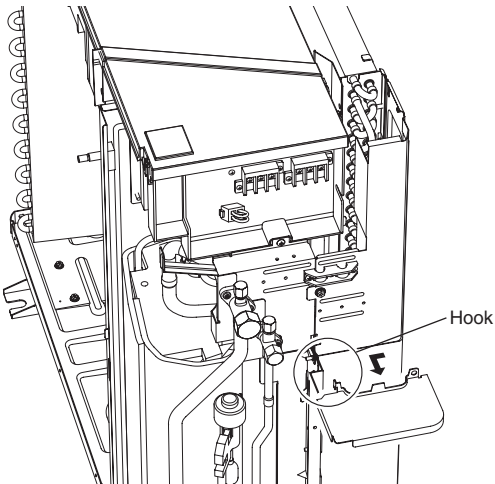
Step	Procedure	Points
11	<p data-bbox="197 215 464 277">Remove the front panel (1).</p>  <p data-bbox="922 667 991 685">(R11400)</p>  <p data-bbox="927 1010 991 1028">(R6995)</p>	<ul style="list-style-type: none"> <li data-bbox="1091 745 1449 837">■ Be sure to detach the front panel (1) carefully so as not to deform it.
7.	<p data-bbox="134 1039 440 1066">Remove the rear panel.</p> <p data-bbox="150 1077 448 1140">1 Remove the screw on the partition plate (2).</p>  <p data-bbox="986 1547 1054 1565">(R13591)</p> <p data-bbox="150 1581 461 1675">2 Slide the partition plate (2) to the left, and remove it.</p>  <p data-bbox="927 2096 995 2114">(R13592)</p>	

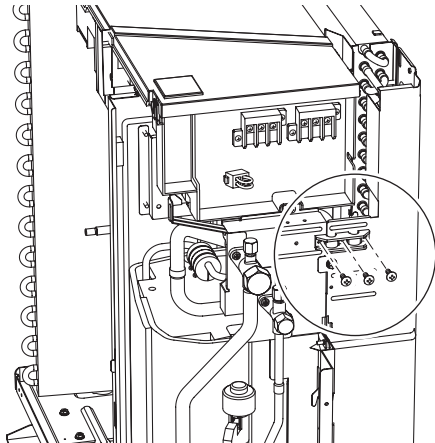
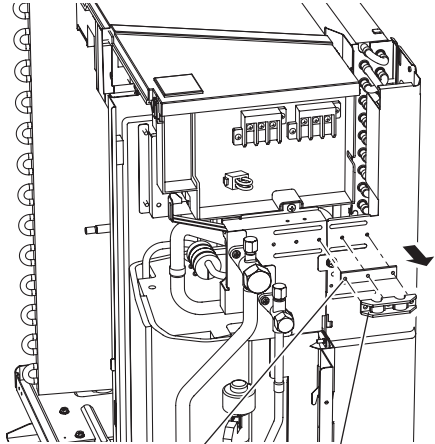
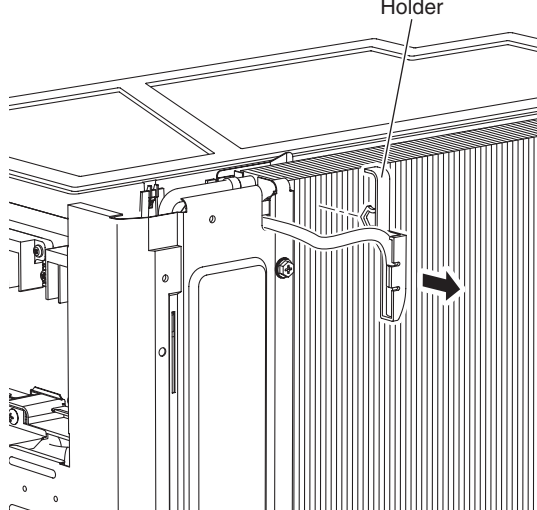
Step	Procedure	Points
3	<p>Remove the 3 screws on the wire fixing plate.</p>  <p>(R13593)</p>	
4	<p>Remove the wire fixing plate and the insulation.</p>  <p>Insulation Wire fixing plate (R13594)</p>	
5	<p>Release the holder of the outdoor temperature thermistor.</p>  <p>Holder (R11151)</p>	<p>■ The holder is secured in the clearances of the outdoor heat exchanger fins.</p>

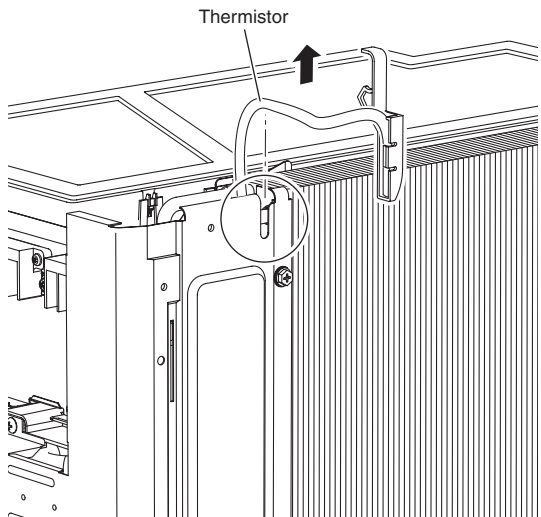
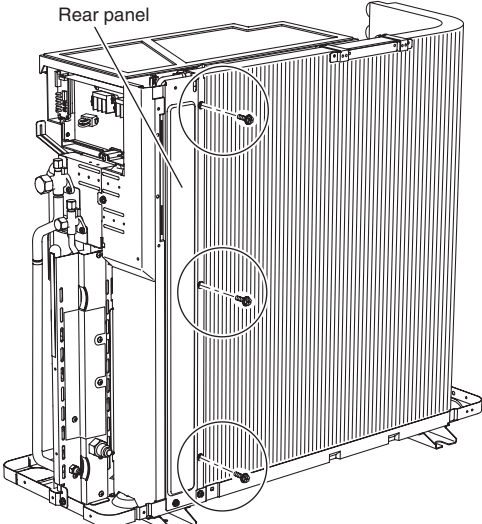
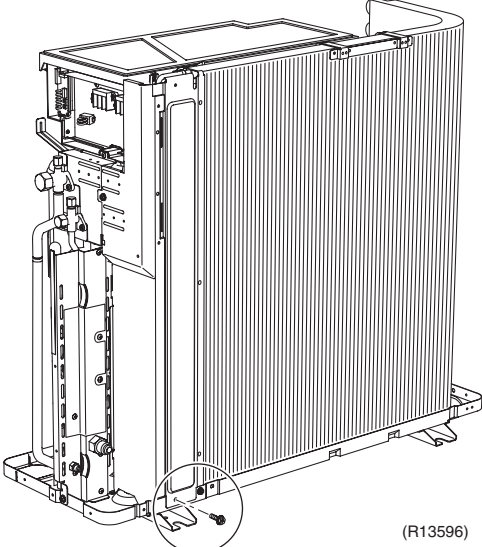
Step		Procedure	Points
6	Release the harness of the outdoor temperature thermistor from the groove.	 <p style="text-align: center;">Thermistor</p> <p style="text-align: right;">(R14991)</p>	
7	Remove the 3 screws on the rear panel.	 <p style="text-align: center;">Rear panel</p> <p style="text-align: right;">(R15002)</p>	
8	Remove the screw on the bottom frame.	 <p style="text-align: right;">(R13596)</p>	

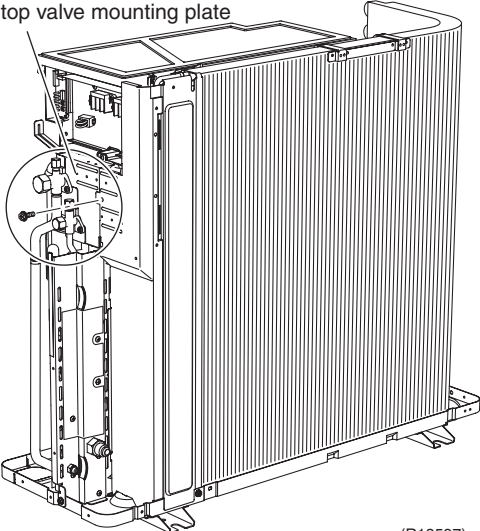
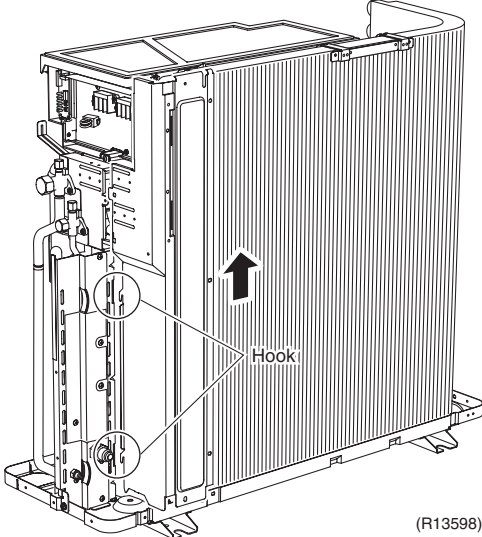
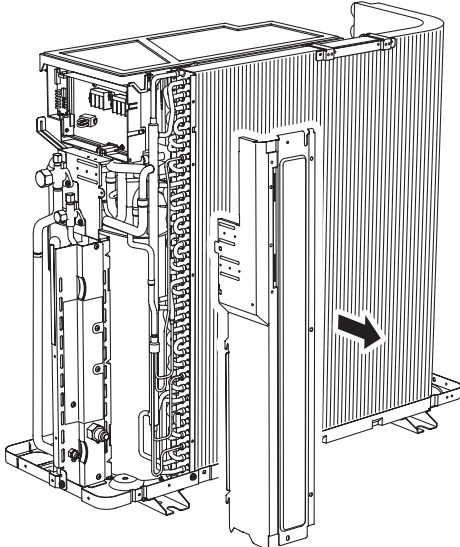
Step		Procedure	Points
9	Remove the screw on the stop valve mounting plate.	<p data-bbox="531 264 778 293">Stop valve mounting plate</p>  <p data-bbox="948 786 1018 808">(R13597)</p>	
10	Lift the rear panel upward to unfasten the 2 hooks.	 <p data-bbox="954 1391 1024 1413">(R13598)</p>	
11	Remove the rear panel.	 <p data-bbox="941 2040 1011 2063">(R13599)</p>	

2. Removal of Electrical Box

Procedure

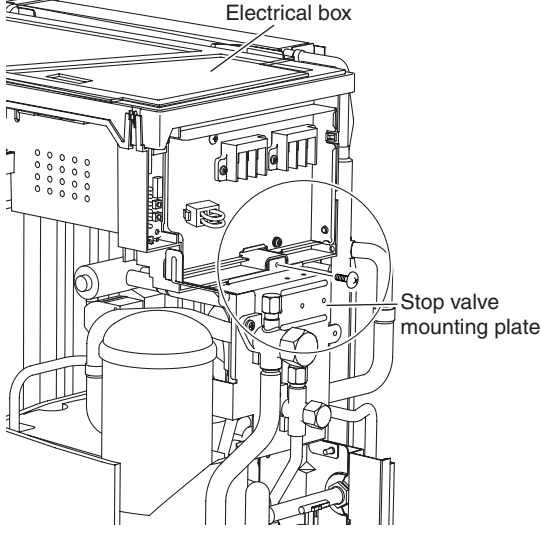
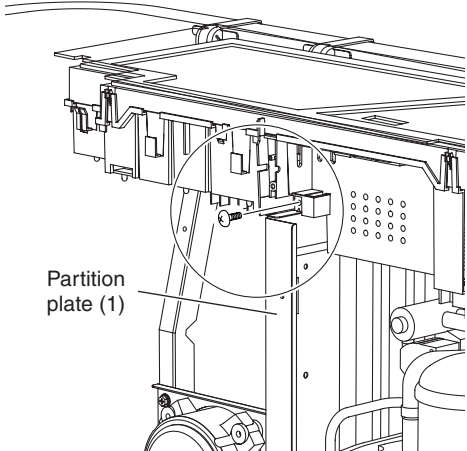
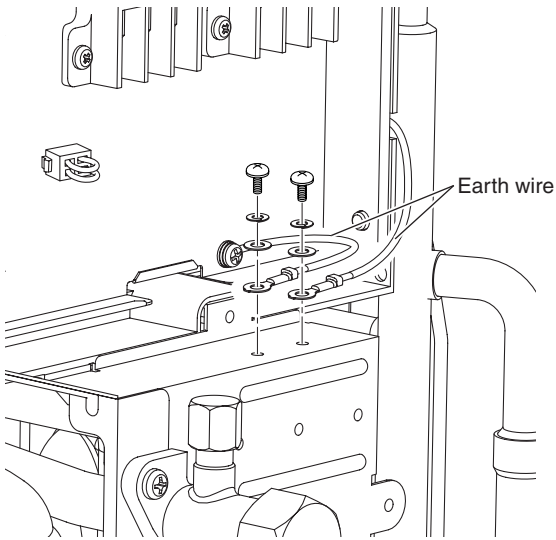

Warning Be sure to wait for 10 minutes or more after turning off all power supplies before disassembling work.

Step	Procedure	Points
1	<p>Remove the screw on the stop valve mounting plate.</p> 	
2	<p>Remove the screw on the partition plate (1).</p> 	
3	<p>Remove the 2 screws to detach the earth wires.</p> 	

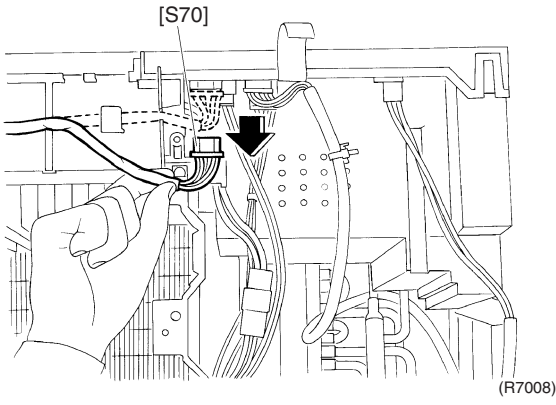
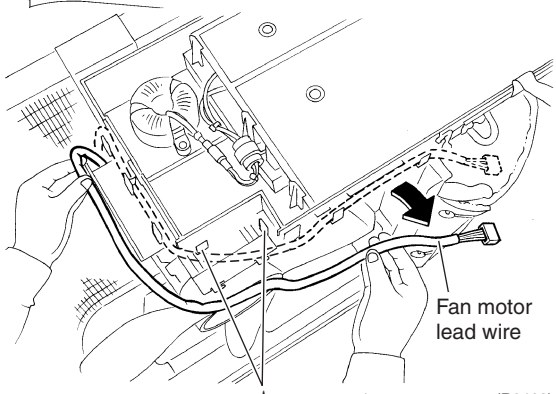
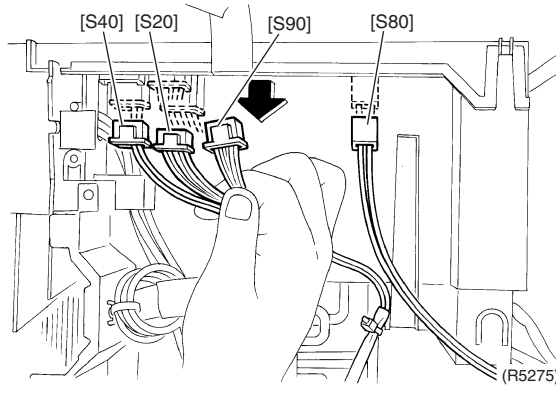
Step	Procedure	Points	
4	Disconnect the connector for the fan motor [S70].		
5	Release the fan motor lead wire from the 5 hooks.		★: When reassembling, do not use these 2 hooks.
6	Disconnect the connectors of the front side.		[S20]: electronic expansion valve coil [S40]: overload protector [S80]: four way valve coil [S90]: thermistors

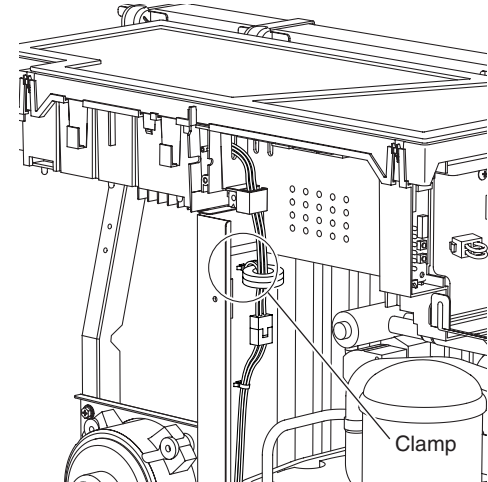
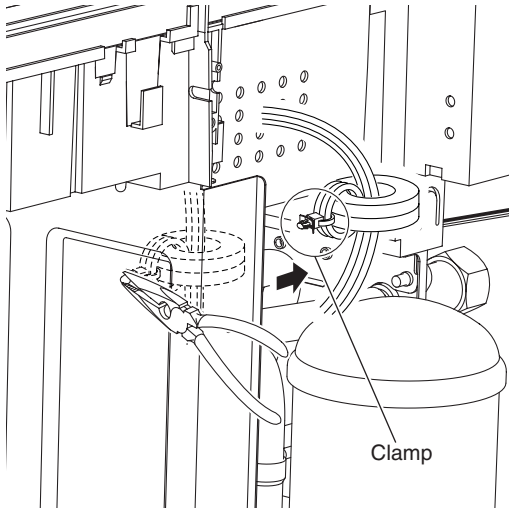
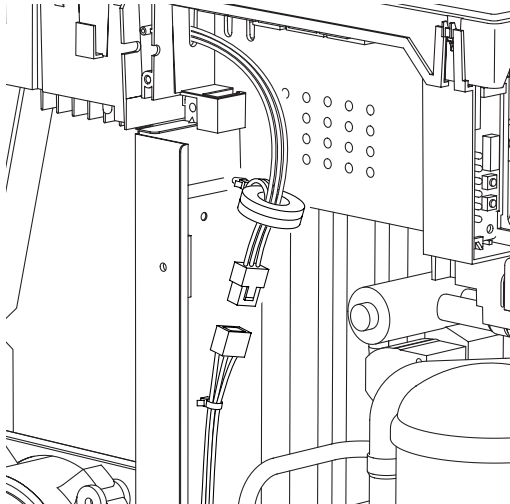
Step	Procedure	Procedure	Points
7	The compressor lead wire is fixed on the partition plate (1) with a clamp.	 <p>(R13602)</p>	
8	Release the clamp of the compressor relay harness with pliers.	 <p>(R6423)</p>	
9	Disconnect the relay connector for the compressor.	 <p>(R6469)</p>	

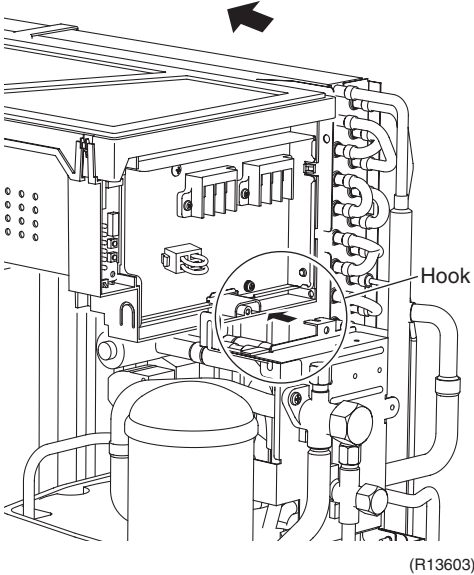
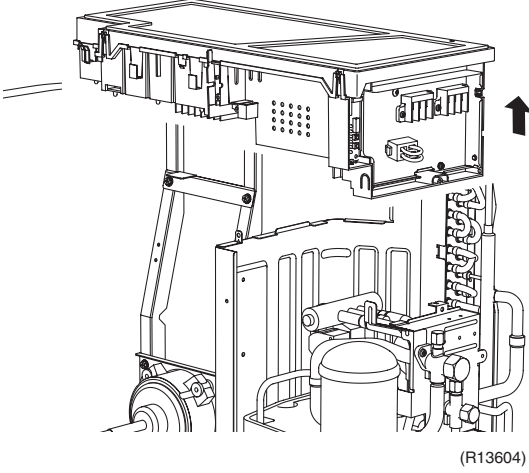
Step	Procedure	Points
10	Slide the electrical box to the left to unfasten the hook on the right side of the box.	
	 <p>(R13603)</p>	
11	Lift up the electrical box and remove it.	
	 <p>(R13604)</p>	

3. Removal of PCBs

Procedure



Warning Be sure to wait for 10 minutes or more after turning off all power supplies before disassembling work.

Step	Procedure	Points
1	Disconnect the connectors [S52] [S102] from the service monitor PCB.	Preparation ■ Remove the electrical box according to the "Removal of Electrical Box".
2	Detach the 4 clamps with pliers and remove the service monitor PCB.	(R13539)
3	Remove the screws of the terminal board and the earth wire.	(R13540)
4	Remove the selective connector for standby electricity saving.	■ Be careful not to lose the connector.

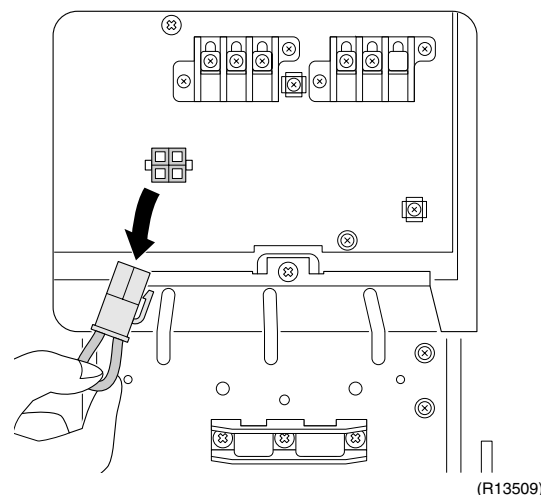
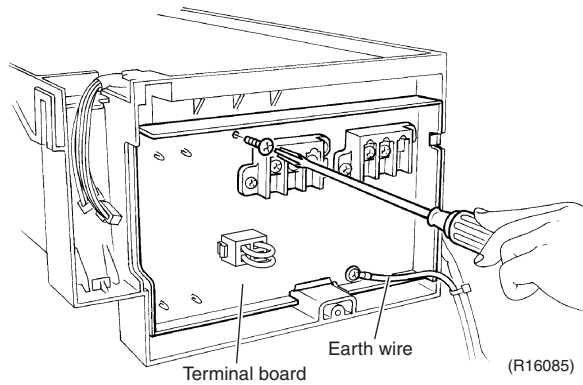
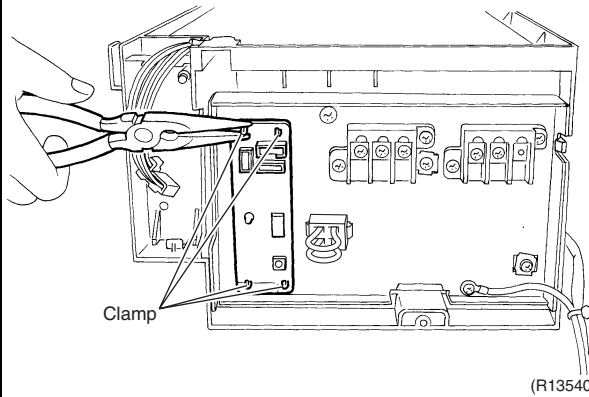
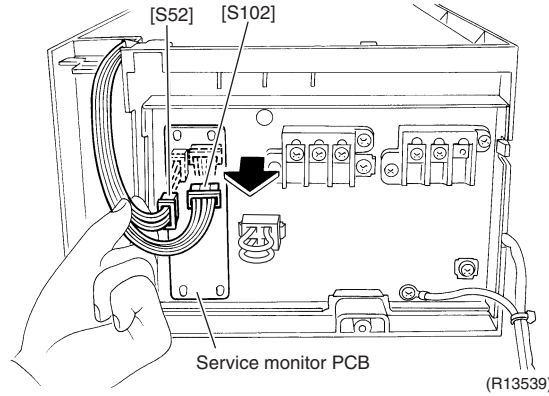

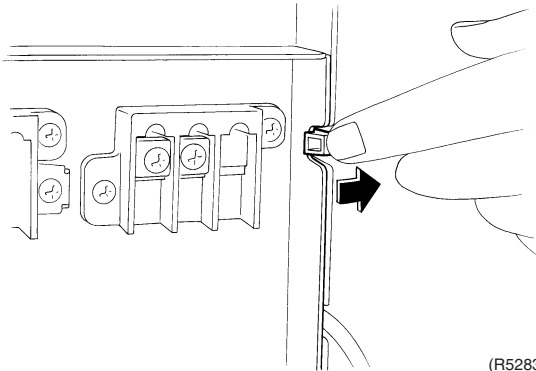
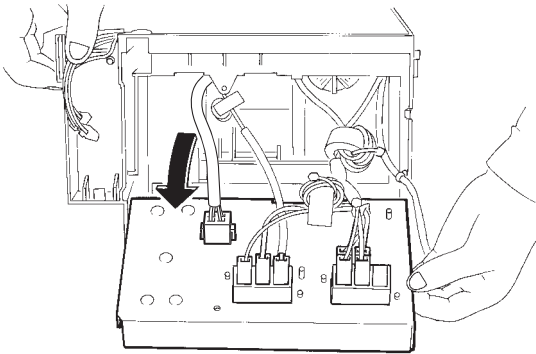
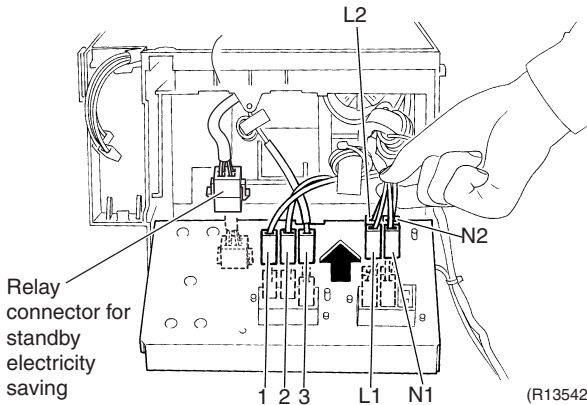
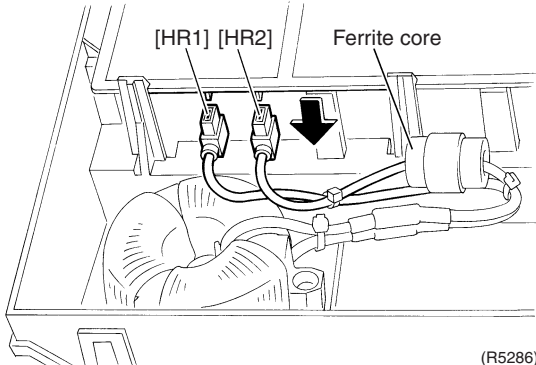
Step	Procedure	Points
5	<p>Unfasten the hook on the right.</p>  <p>(R5283)</p>	
6	<p>Open the terminal board.</p>  <p>(R13543)</p>	
7	<p>Disconnect the harnesses. Pull out the relay connector for standby electricity saving from the terminal board.</p>  <p>(R13542)</p>	<p>1: Black 2: White 3: Red L1: Black L2: Brown N1: White N2: Blue</p>
8	<p>Disconnect the 2 harnesses for the reactor [HR1] [HR2].</p>  <p>(R5286)</p>	<p>[HR1] : White [HR2] : Blue</p> <p>■ The harness for [HR2] has a ferrite core.</p>

Step	Procedure	Points
9	Remove the 3 screws of the main PCB.	
10	Release the 4 hooks.	
11	Lift up and remove the main PCB.	

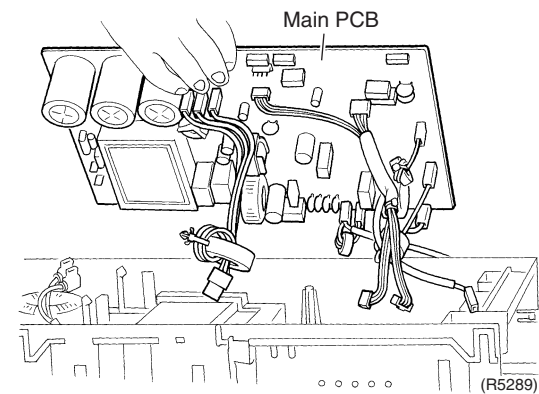
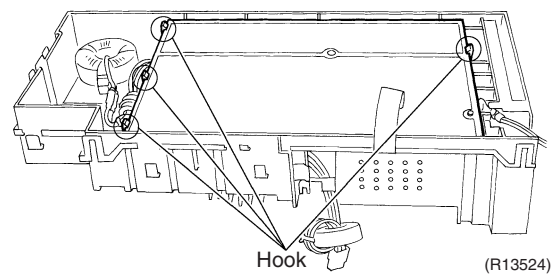
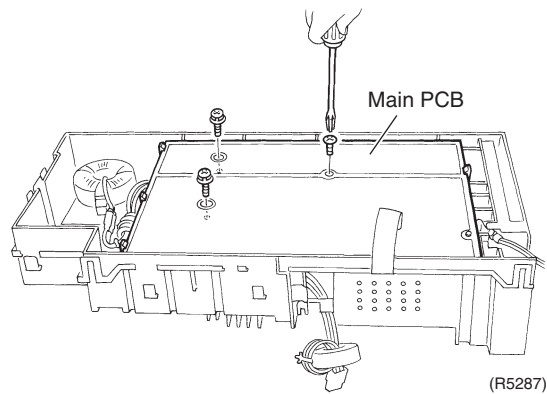

4. Removal of Fan Motor

Procedure



Warning Be sure to wait for 10 minutes or more after turning off all power supplies before disassembling work.

Step	Procedure	Procedure	Points
1	Remove the 2 lower screws first.	<p style="text-align: right;">(R6442)</p>	<ul style="list-style-type: none"> Be sure to remove the lower screws first. If the upper screws are removed first, the fan motor may tilt down or fall and cause injury because its center of gravity is shifted to the front.
2	Then, remove the 2 upper screws.	<p style="text-align: right;">(R6442)</p>	
3	Remove the fan motor.	<p style="text-align: right;">(R6443)</p>	<ul style="list-style-type: none"> When reassembling, make sure that the wire harness is facing downward. <p style="text-align: right;">(R6444)</p>

5. Removal of Coils / Thermistors

Procedure

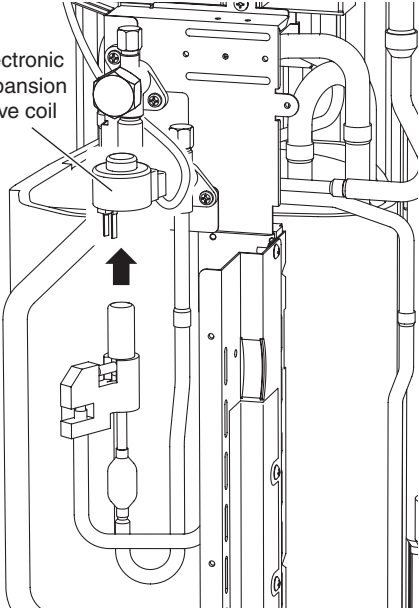
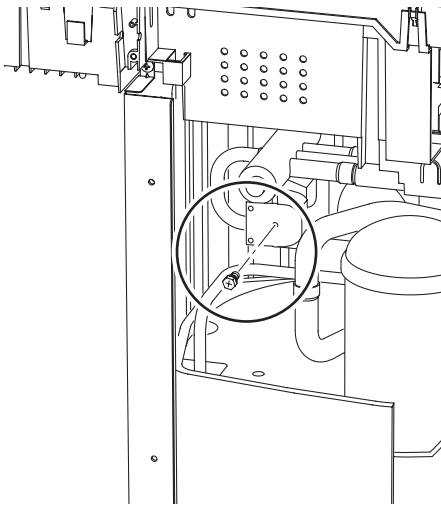
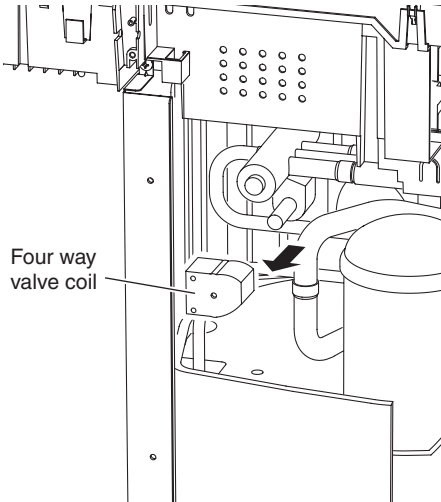

Warning Be sure to wait for 10 minutes or more after turning off all power supplies before disassembling work.

Step	Procedure	Points
1. Remove the electronic expansion valve coil. 1 Pull the electronic expansion valve coil out.	 <p>Electronic expansion valve coil</p> <p>(R11159)</p>	
2. Remove the four way valve coil. 1 Remove the screw. 2 Remove the four way valve coil.	 <p>(R6457)</p>  <p>Four way valve coil</p> <p>(R6458)</p>	

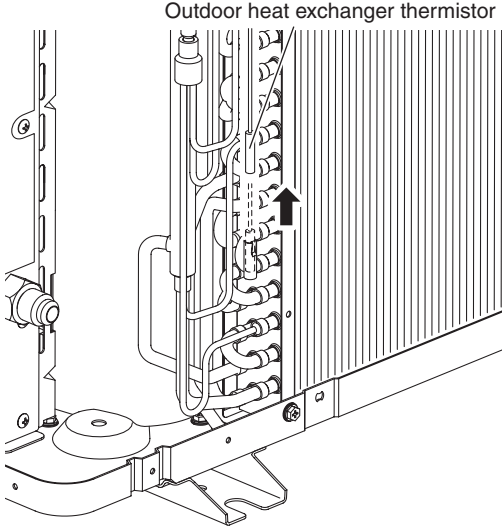
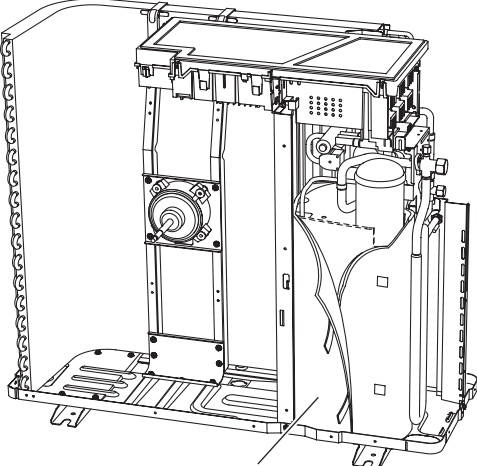
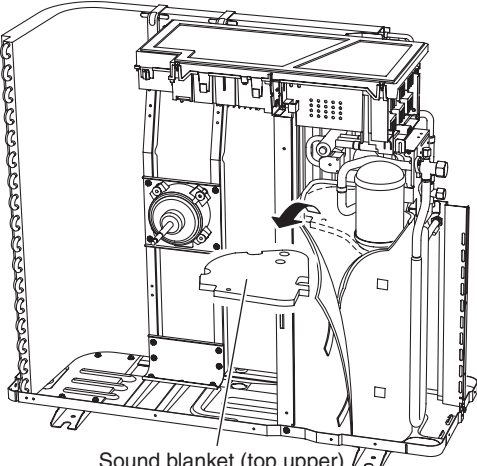
Step	Procedure	Points
<p>3. Remove the thermistors.</p>	<p>1 Pull out the outdoor heat exchanger thermistor.</p>  <p>(R11160)</p> <p>2 Slightly open the sound blanket (outer).</p>  <p>(R7011)</p> <p>3 Remove the sound blanket (top upper).</p>  <p>(R7012)</p>	

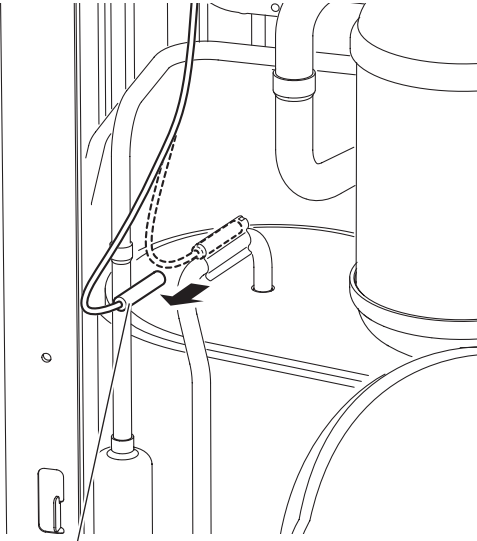
Step	Procedure	Points
4	<p data-bbox="199 215 454 280">Remove the discharge pipe thermistor.</p>  <p data-bbox="582 828 837 862">Discharge pipe thermistor</p> <p data-bbox="965 840 1029 862">(R9469)</p>	

6. Removal of Sound Blankets

Procedure



Warning Be sure to wait for 10 minutes or more after turning off all power supplies before disassembling work.

Step	Procedure	Points
1	Open the sound blanket (outer).	
2	Remove the sound blanket (top upper).	<ul style="list-style-type: none"> ■ The sound blanket is fragile. Carefully pass the discharge pipe through it.
3	Remove the screw and slightly push the partition plate (1) to the left for easy work.	

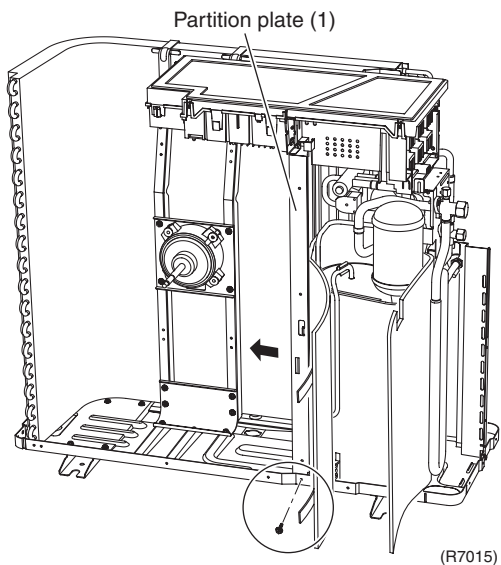
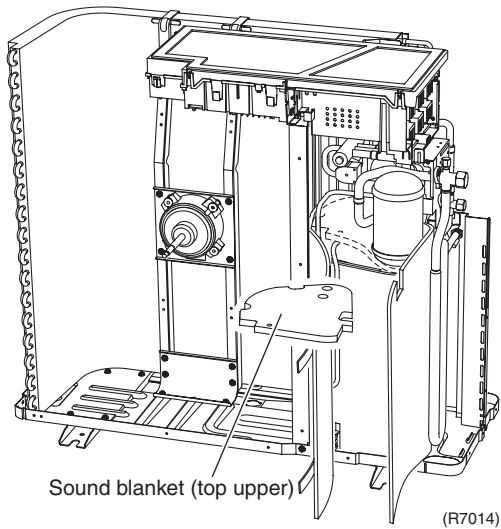
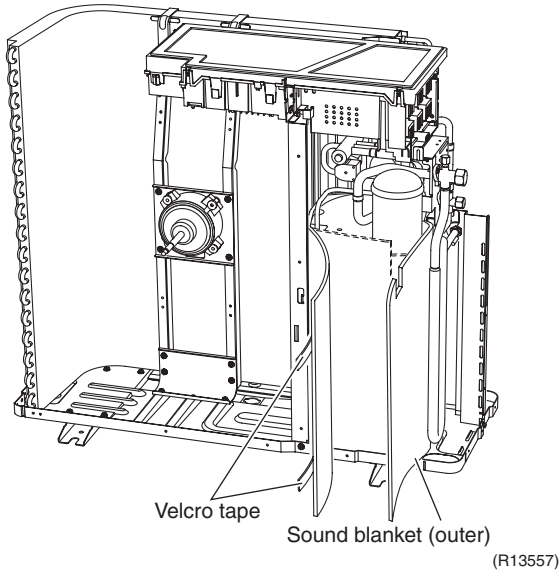

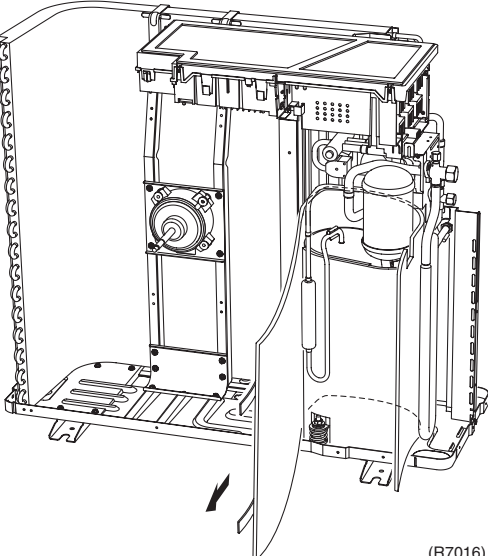
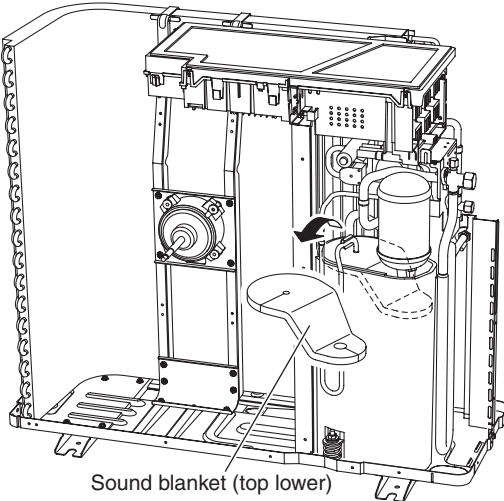
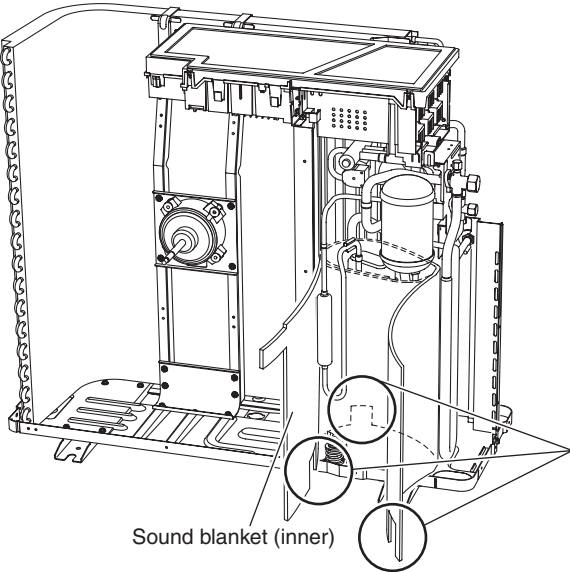
Step	Procedure	Procedure	Points
4	Remove the sound blanket (outer).	 <p>(R7016)</p>	
5	Remove the sound blanket (top lower).	 <p>Sound blanket (top lower)</p> <p>(R7017)</p>	<ul style="list-style-type: none"> ■ The sound blanket is fragile. Carefully pass the discharge pipe through it.
6	Open the sound blanket (inner).	 <p>Sound blanket (inner)</p> <p>(R7018)</p>	<ul style="list-style-type: none"> ■ The sound blanket is fragile. Be careful of the notches of the compressor mount (3 locations).

Step	Procedure	Points
7	Remove the sound blanket (inner).	

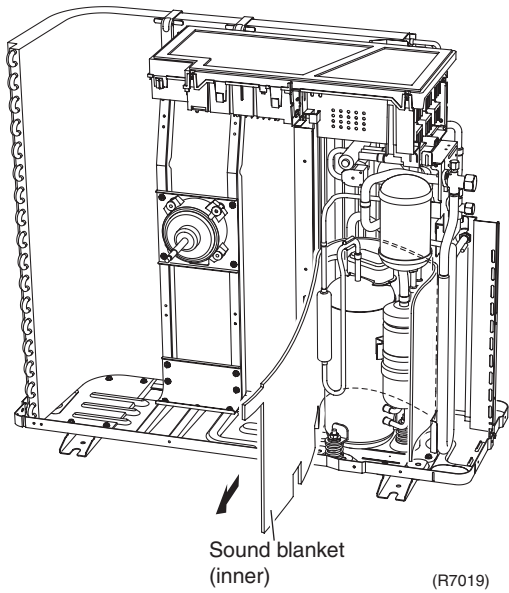

7. Removal of Compressor

Procedure



Warning Be sure to wait for 10 minutes or more after turning off all power supplies before disassembling work.

Step	Procedure	Points
1	Remove the terminal cover.	■ U: red, V: yellow, W: blue
2	Pull out the 3 lead wires.	
3	Remove the overload protector (OL).	

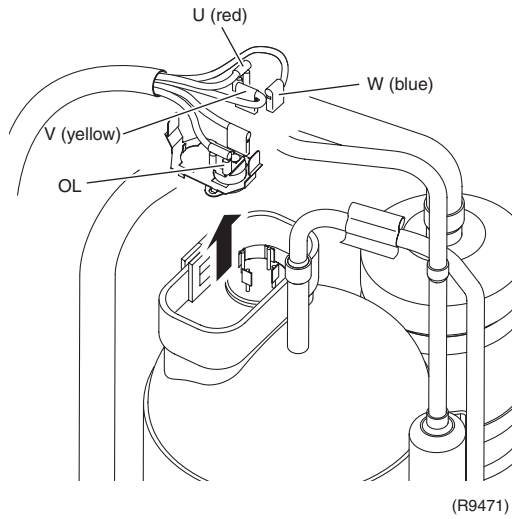
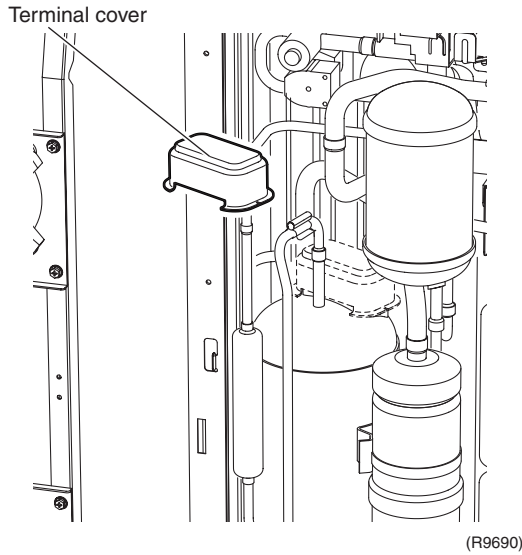

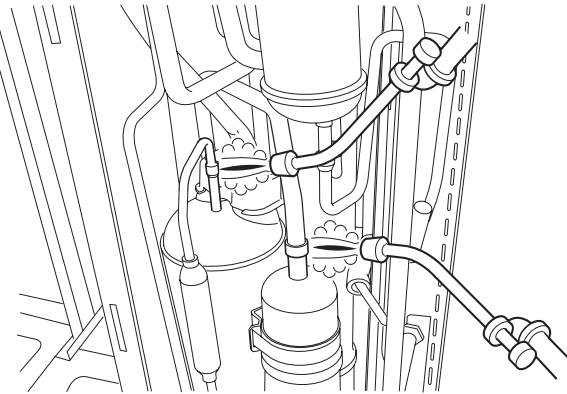
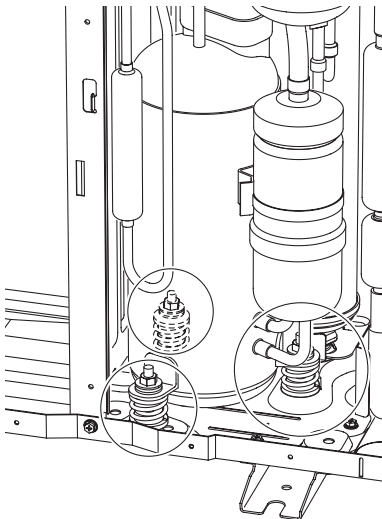
Step	Procedure	Points
<ul style="list-style-type: none"> ■ Before working, make sure that the refrigerant gas is empty in the circuit. ■ Be sure to apply nitrogen replacement when heating up the brazed part. 	 <p style="text-align: right;">(R9646)</p>	<p>Warning Be careful not to get yourself burnt with the pipes and other parts that are heated by the gas brazing machine.</p>
4	Heat up the brazed part and withdraw the piping with pliers.	<p>Warning If the refrigerant gas leaks during work, ventilate the room. (If the refrigerant gas is exposed to flames, toxic gas may be generated.)</p>
5	Remove the 3 nuts.	<p>Warning Since it may happen that the refrigerant oil in the compressor catches fire, prepare wet cloth so as to extinguish fire immediately.</p> <p>Caution From the viewpoint of global environment protection, do not discharge the refrigerant gas in the atmosphere. Make sure to collect all the refrigerant gas.</p> <p>Cautions for restoration</p> <ol style="list-style-type: none"> 1. Restore the piping by non-oxidation brazing. 2. It is required to prevent the carbonization of the oil inside the four way valve and the deterioration of the gaskets affected by heat. (Keep below 120°C.) For the sake of this, wrap the four way valve with wet cloth and provide water so that the cloth does not dry. <p>In case of difficulty with gas brazing machine</p> <ol style="list-style-type: none"> 1. Disconnect the brazed part where is easy to disconnect and restore. 2. Cut pipes on the main unit with a tube cutter in order to make it easy to disconnect.
<p>Note:</p> <ul style="list-style-type: none"> ■ Do not use a metal saw for cutting pipes by all means because the sawdust comes into the circuit. ■ When withdrawing the pipes, be careful not to pinch them firmly with pliers. The pipes may get deformed. ■ Provide a protective sheet or a steel plate so that the brazing flame cannot influence peripheries. ■ Be careful so as not to burn the compressor terminals, the name plate, the heat exchanger fin. 	 <p style="text-align: right;">(R7021)</p>	

Revision History

Month / Year	Version	Revised contents
08/2012	Si001167	First edition

Warning



- Daikin products are manufactured for export to numerous countries throughout the world. Prior to purchase, please confirm with your local authorised importer, distributor and/or retailer whether this product conforms to the applicable standards, and is suitable for use, in the region where the product will be used. This statement does not purport to exclude, restrict or modify the application of any local legislation.
- Ask a qualified installer or contractor to install this product. Do not try to install the product yourself. Improper installation can result in water or refrigerant leakage, electrical shock, fire or explosion.
- Use only those parts and accessories supplied or specified by Daikin. Ask a qualified installer or contractor to install those parts and accessories. Use of unauthorised parts and accessories or improper installation of parts and accessories can result in water or refrigerant leakage, electrical shock, fire or explosion.
- Read the User's Manual carefully before using this product. The User's Manual provides important safety instructions and warnings. Be sure to follow these instructions and warnings.

If you have any enquiries, please contact your local importer, distributor and/or retailer.

Cautions on product corrosion

1. Air conditioners should not be installed in areas where corrosive gases, such as acid gas or alkaline gas, are produced.
2. If the outdoor unit is to be installed close to the sea shore, direct exposure to the sea breeze should be avoided. If you need to install the outdoor unit close to the sea shore, contact your local distributor.

Dealer

DAIKIN INDUSTRIES, LTD.

Head Office:
Umeda Center Bldg., 2-4-12, Nakazaki-Nishi,
Kita-ku, Osaka, 530-8323 Japan

Tokyo Office:
JR Shinagawa East Bldg., 2-18-1, Konan,
Minato-ku, Tokyo, 108-0075 Japan

http://www.daikin.com/global_ac/

©All rights reserved