



REMOVAL PROCEDURE



S E R V I C E M A N U A L

4.6/5.0/6.0 kW Class 18000 Btu/h Class

-  Outdoor Unit
-  Inverter
-  Pair Type



Service Manual Removal Procedure

Outdoor Unit

Applicable Models

●Cooling Only

**RKS18HV2S
RKS50KVMA
RKS60KVMA**

**RKS50KAVMA
RKS60KAVMA**

●Heat Pump

RXG50K2V1B

**RXS50KVM
RXS60KVM**

**RXS46KVMA
RXS50KVMA
RXS60KVMA**

**RXS50KAVMA
RXS60KAVMA**

Table of Contents

1. Removal of Outer Panels	2
2. Removal of Outdoor Fan / Fan Motor	5
3. Removal of Electrical Box	8
4. Removal of PCBs.....	12
5. Removal of Sound Blankets / Thermistors.....	15
6. Removal of Four Way Valve	17
7. Removal of Electronic Expansion Valve	18
8. Removal of Compressor	19



Note:

- ♦ The illustrations may be slightly different depending on the model.
- ♦ The illustrations are for heat pump models as representative.

1. Removal of Outer Panels

Procedure

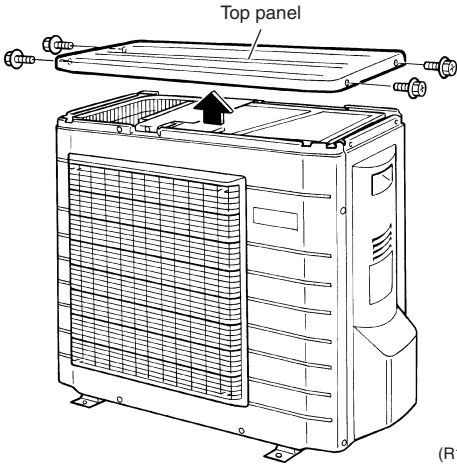
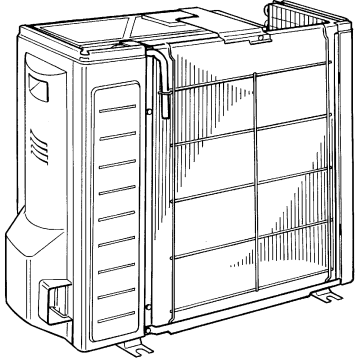
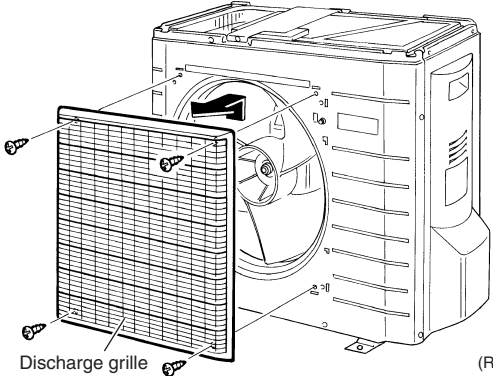
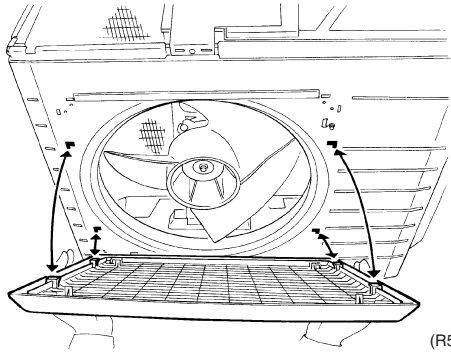

Warning Be sure to wait for 10 minutes or more after turning off all power supplies before disassembling work.

Step	Procedure	Points
<p>1. Remove the panels.</p> <p>1 Remove the 4 screws and lift the top panel.</p> <p>2 Remove the 4 screws and remove the discharge grille.</p>	 <p style="text-align: right;">(R12283)</p>  <p style="text-align: right;">(R12315)</p>  <p style="text-align: right;">(R5245)</p>  <p style="text-align: right;">(R5246)</p>	<ul style="list-style-type: none"> ■ Take care not to cut your finger by the fins of the outdoor heat exchanger. ■ Slide the discharge grille upward and remove it. ■ The discharge grille has 4 hooks.

Step	Procedure	Points
3	Remove the 6 screws of the front panel.	
4	Push the front panel and lift the shield plate to unfasten the hooks.	
5	Unfasten the left side hooks, and then the right side hook. Remove the front panel.	<ul style="list-style-type: none"> ■ Lift the front panel while pushing the left side panel inward. ■ Lift the front panel and unfasten the right side hook.

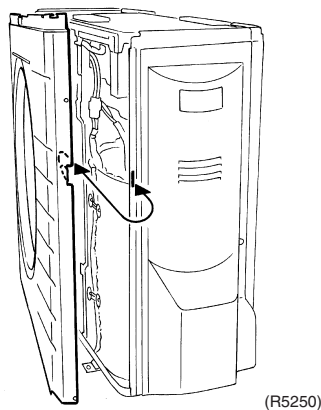
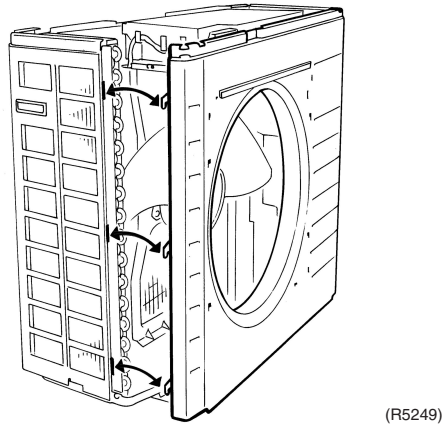
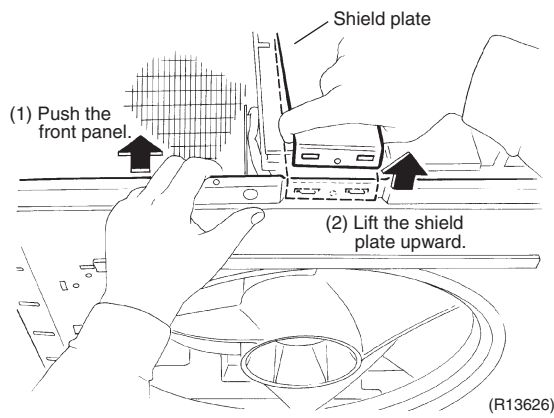
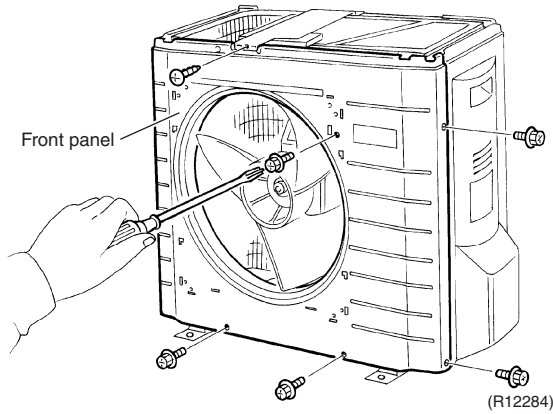

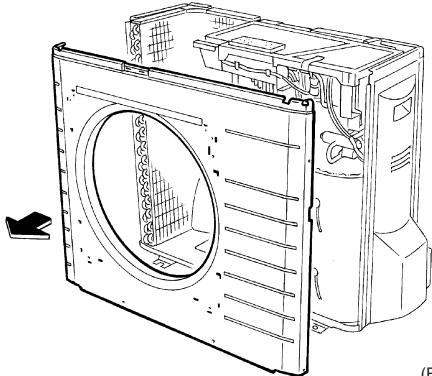
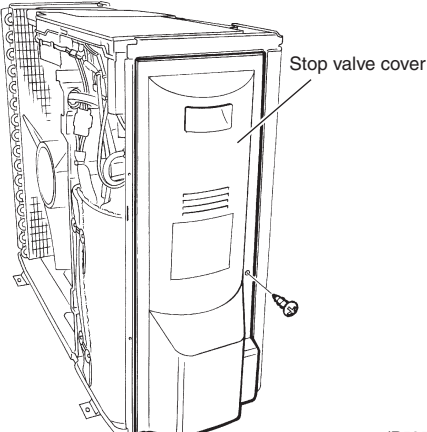
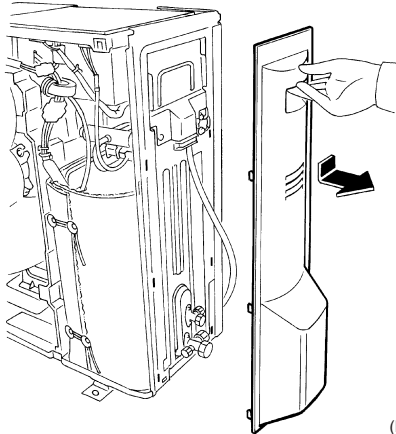
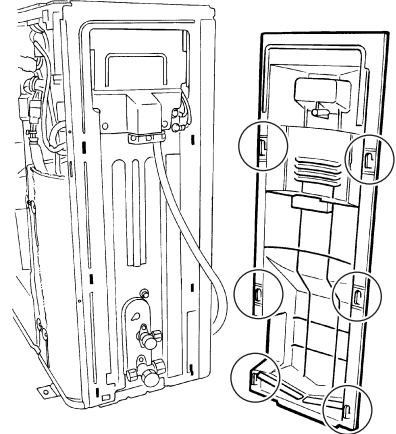
Step	Procedure	Points
	 <p style="text-align: right;">(R5251)</p>	<ul style="list-style-type: none"> ■ When reassembling, fit the right side of the front panel first.
<p>2. Remove the stop valve cover.</p> <p>1</p> <p>2</p>	<p>Remove the screw of the stop valve cover.</p>  <p style="text-align: right;">(R5252)</p> <p>Pull the stop valve cover downward to unfasten the hooks and remove it.</p>  <p style="text-align: right;">(R5253)</p>  <p style="text-align: right;">(R5254)</p>	<ul style="list-style-type: none"> ■ The stop valve cover has 6 hooks.

2. Removal of Outdoor Fan / Fan Motor

Procedure



Warning Be sure to wait for 10 minutes or more after turning off all power supplies before disassembling work.

Step	Procedure	Points
1.	Remove the electrical box cover.	Preparation
1	Remove the screw of the shield plate.	<ul style="list-style-type: none"> ■ Remove the top panel and the front panel according to the "Removal of Outer Panels".
2	Unfasten the 2 hooks and remove the shield plate.	<ul style="list-style-type: none"> ■ This procedure is not necessary to remove the outdoor fan only.
3	Unfasten the 4 hooks of the electrical box cover and remove it.	

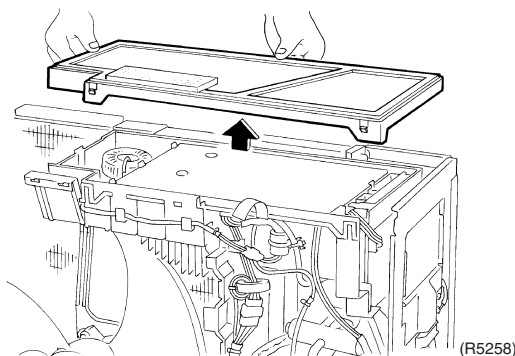
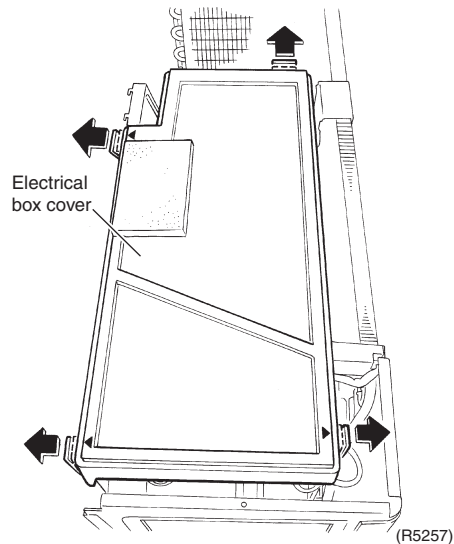
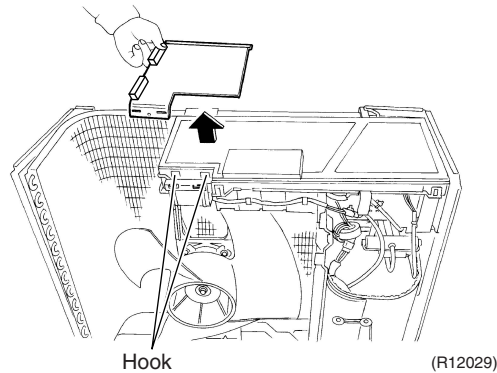
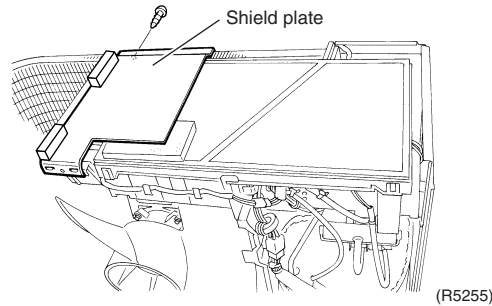

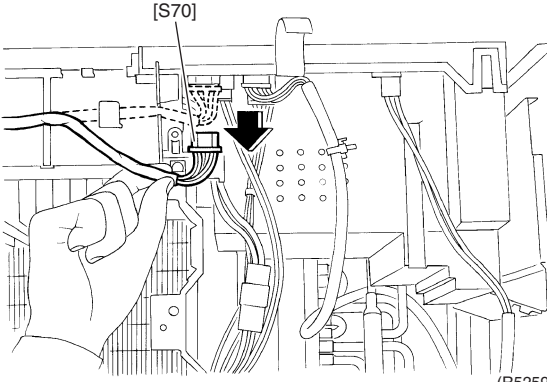
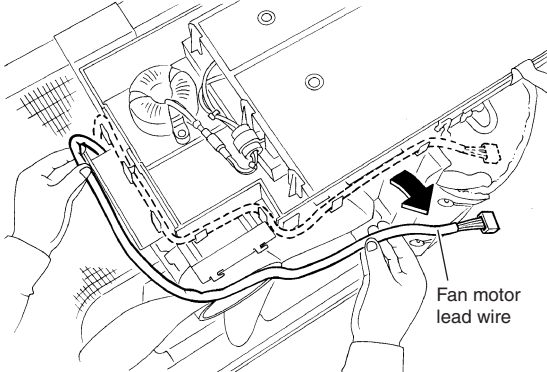
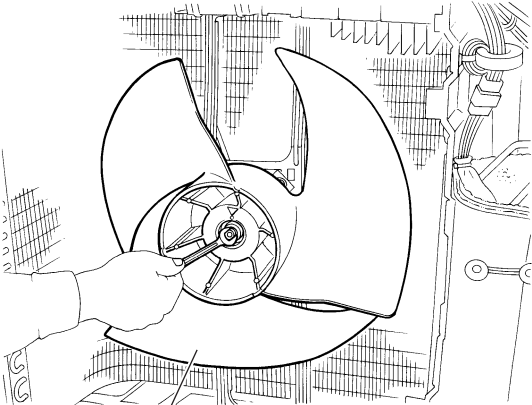
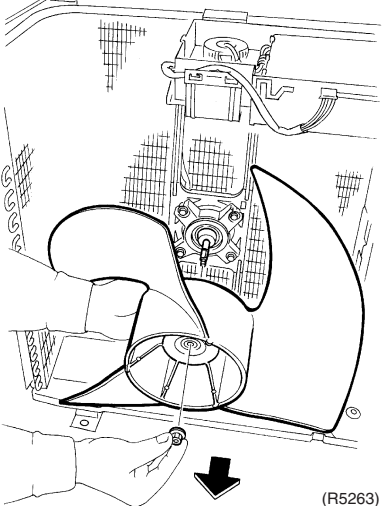
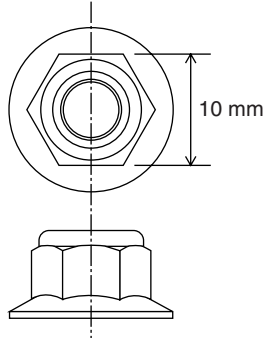
Step	Procedure	Points
<p>2. Remove the fan motor.</p> <p>1 Disconnect the connector for the fan motor [S70].</p> <p>2 Release the fan motor lead wire from the 7 hooks.</p> <p>3 Remove the nut of the outdoor fan.</p>	 <p>(R5259)</p>  <p>Fan motor lead wire</p> <p>(R5260)</p>  <p>Outdoor fan</p> <p>(R5262)</p>  <p>(R5263)</p>	<p>■ Nut size: M6</p>  <p>10 mm</p> <p>(R12236)</p> <p>■ When reassembling, align the ▼ mark of the outdoor fan with the D-cut section of the motor shaft.</p>

Step	Procedure	Points
4	Remove the 2 lower screws from the fan motor first.	
5	Then, remove the 2 upper screws.	<ul style="list-style-type: none"> ■ Be sure to remove the lower screws first. If the upper screws are removed first, the fan motor may tilt down or fall and cause injury because its center of gravity is shifted to the front.
6	Release the fan motor lead wire from the 2 hooks and pull the fan motor out.	<ul style="list-style-type: none"> ■ When reassembling, put the fan motor lead wire through the back of the fan motor so as not to be entangled with the outdoor fan.

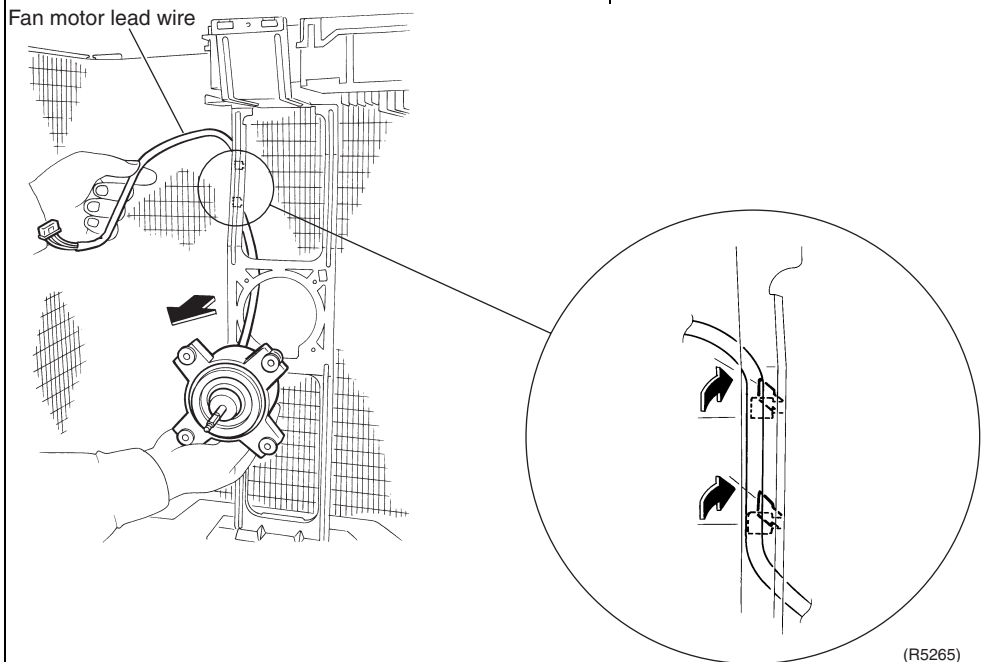
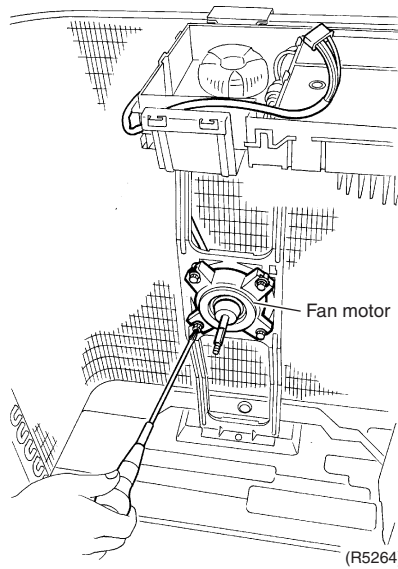

3. Removal of Electrical Box

Procedure



Warning Be sure to wait for 10 minutes or more after turning off all power supplies before disassembling work.

Step	Procedure	Points
1	Remove the 2 screws of the shield plate.	<p>Preparation</p> <ul style="list-style-type: none"> Remove the top panel and the front panel according to the "Removal of Outer Panels".
<p style="text-align: right;">Shield plate (R17060)</p>		
2	Slide the shield plate upward to unfasten the hook on the bottom left, and then remove the shield plate.	
<p style="text-align: center;">Hook (R17021)</p>		
3	Remove all the screws of the terminal boards and of the earth wires. Disconnect the power supply wire and the connection wire.	
<p style="text-align: right;">Earth wire (R17239)</p> <p style="text-align: center;">Connection wire Power supply wire</p>		
4	Disconnect the 2 earth wires.	
<p style="text-align: right;">Earth wire (R17240)</p>		

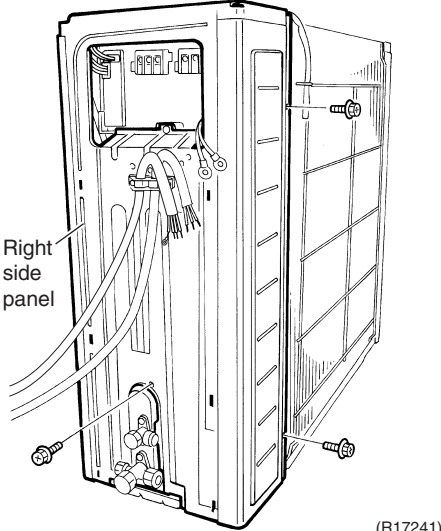
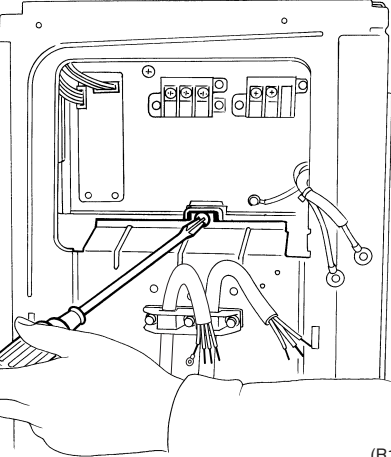
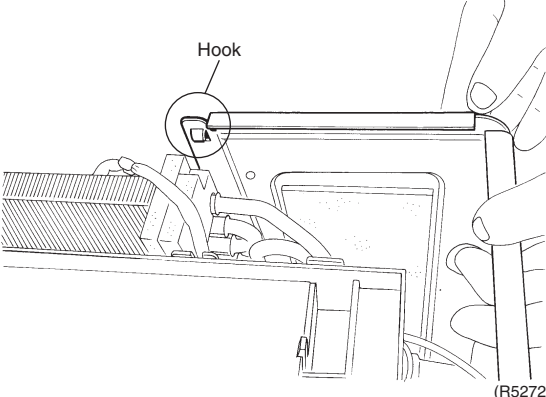
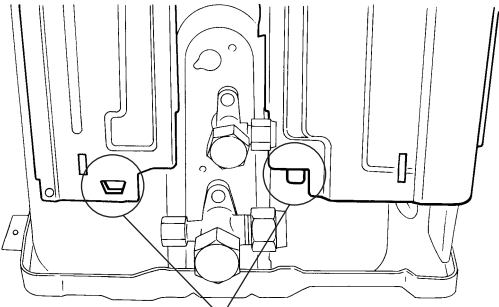
Step	Procedure	Points
5	<p>Remove the 3 screws of the right side panel.</p>  <p>Right side panel</p> <p>(R17241)</p>	
6	<p>Remove the screw of the electrical box.</p>  <p>(R17242)</p>	
7	<p>Unfasten the hooks and remove the right side panel.</p>  <p>Hook</p> <p>(R5272)</p>  <p>Hook</p> <p>(R13586)</p>	<p>■ When reassembling, insert the upper hook and the 2 lower hooks back into place.</p>

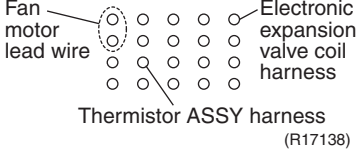
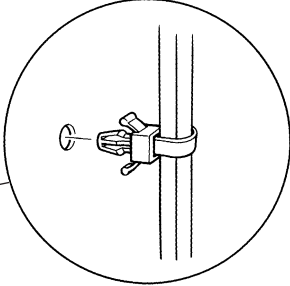
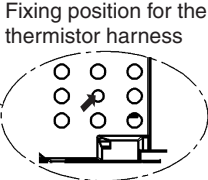
Step	Procedure	Points
8	Disconnect the connectors of the front side.	<p>[S20]: electronic expansion valve coil [S40]: overload protector [S80]: four way valve coil [S90]: thermistors</p> <p>■ When reassembling, insert each clamp into the hole as below.</p> 
9	Disconnect the relay connector for the compressor.	
10	Release the clamp.	
11	Detach the clamp and release the thermistor lead wires from the hook.	<p>■ When reassembling, insert the clamp into the small hole.</p> 
12	Remove the screw.	

Step	Procedure	Points
13	Release the harness of the outdoor temperature thermistor from the hook.	
14	Lift and remove the electrical box.	

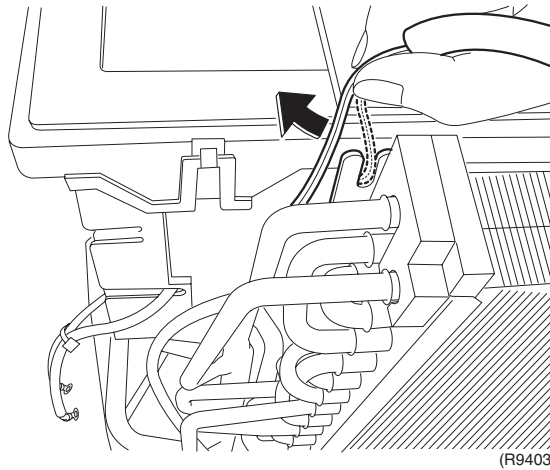

(R9403)

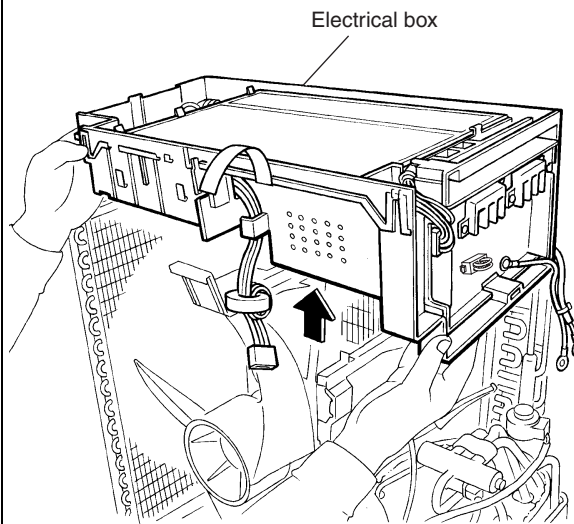

(R13587)

4. Removal of PCBs

Procedure



Warning Be sure to wait for 10 minutes or more after turning off all power supplies before disassembling work.

Step	Procedure	Points
1	Disconnect the connectors [S52] [S102] from the service monitor PCB.	<p>Preparation</p> <ul style="list-style-type: none"> Remove the electrical box according to the "Removal of Electrical Box".
2	Detach the 4 clamps with pliers and remove the service monitor PCB.	
3	Remove the screws of the terminal board and the earth wire.	
4	Remove the selective connector for standby electricity saving.	<ul style="list-style-type: none"> Be careful not to lose the connector. Some models have no selective connector for standby electricity saving.

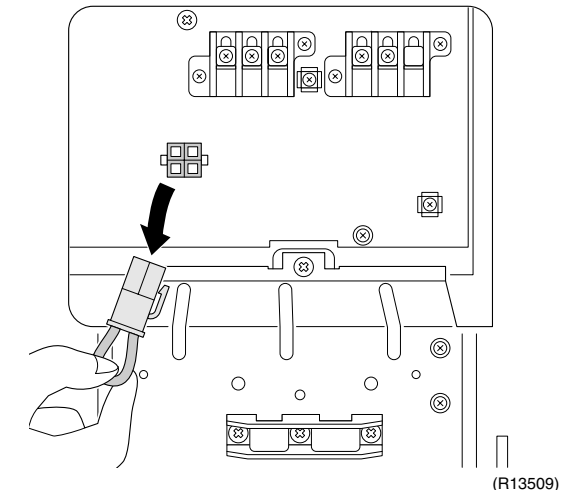
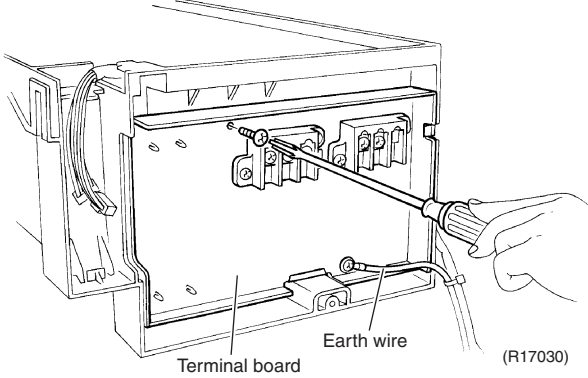
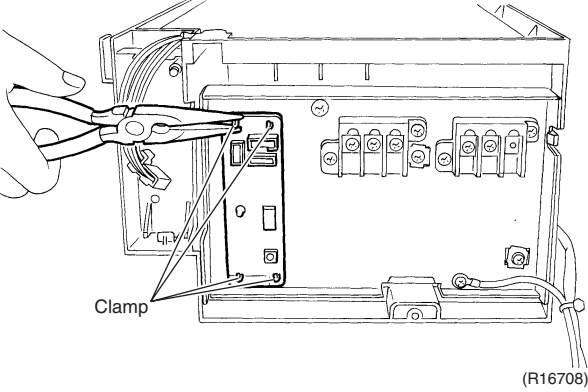
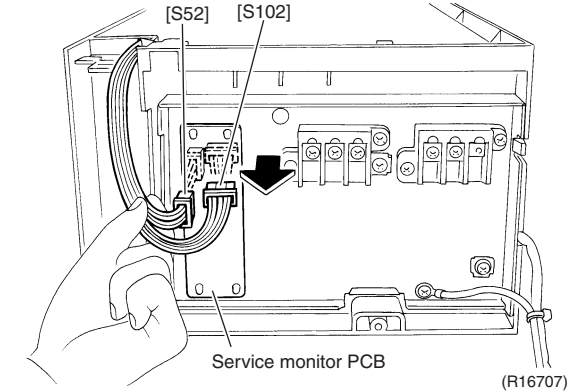

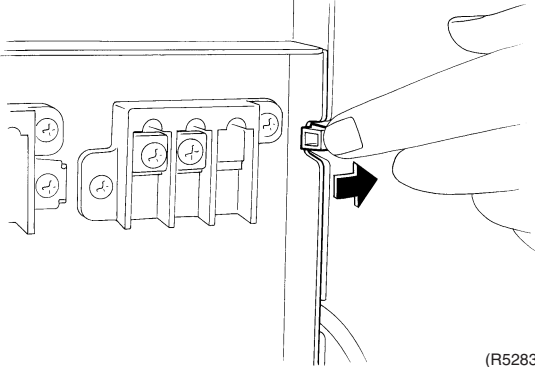
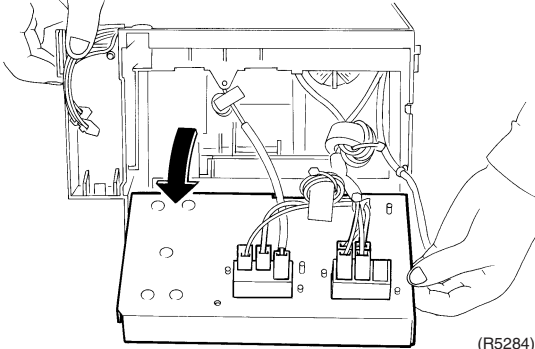
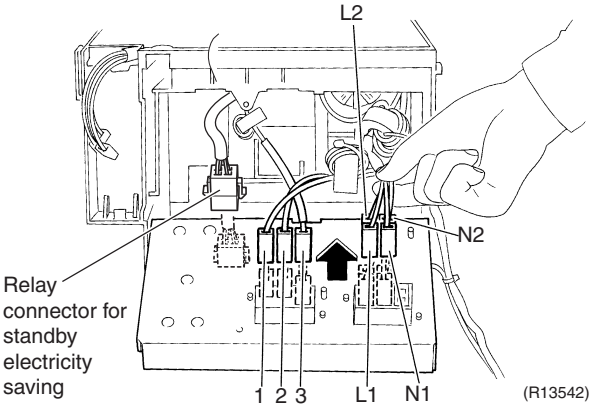
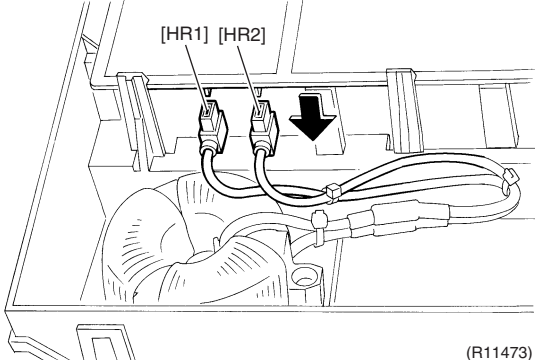
Step	Procedure	Points
5	Unfasten the hook on the right.  <p style="text-align: right;">(R5283)</p>	
6	Open the terminal board.  <p style="text-align: right;">(R5284)</p>	
7	Disconnect the harnesses. Pull out the relay connector for standby electricity saving from the terminal board.  <p style="text-align: right;">(R13542)</p>	1: Black 2: White 3: Red L1: Black L2: Brown N1: White N2: Blue ■ Some models have no relay connector for standby electricity saving.
8	Disconnect the 2 connectors for the reactor [HR1] [HR2].  <p style="text-align: right;">(R11473)</p>	

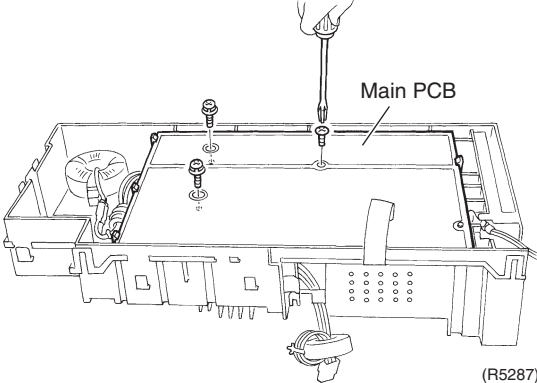
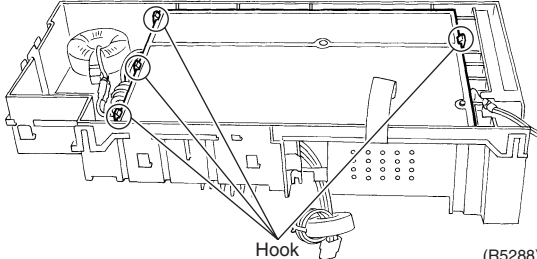
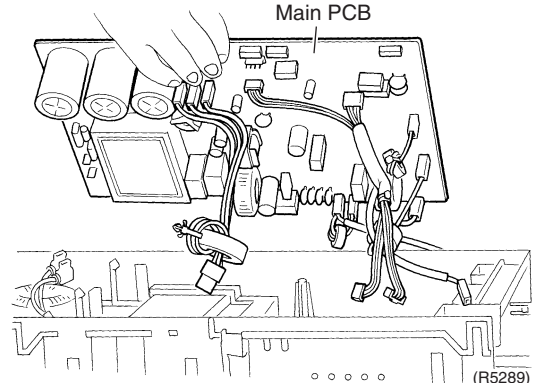
Step	Procedure	Points
9	<p>Remove the 3 screws of the main PCB.</p>  <p>(R5287)</p>	
10	<p>Unfasten the 4 hooks.</p>  <p>(R5288)</p>	
11	<p>Lift up and remove the main PCB.</p>  <p>(R5289)</p>	

5. Removal of Sound Blankets / Thermistors

Procedure

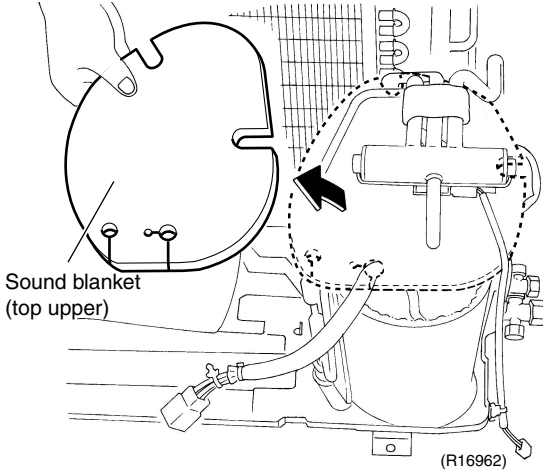
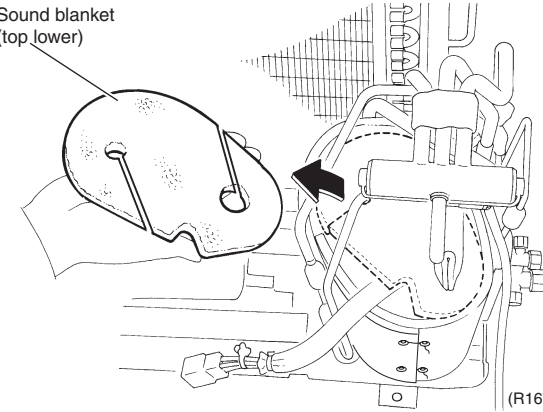
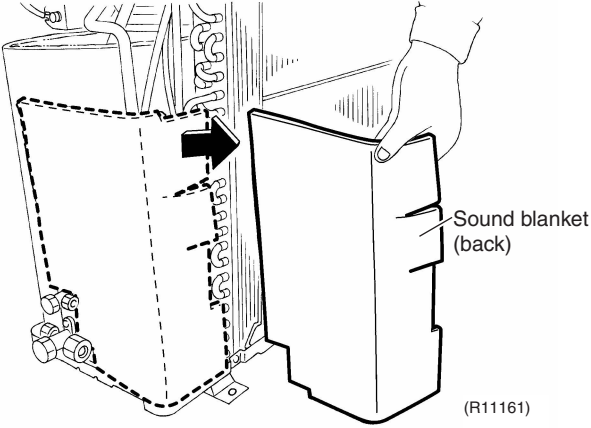

Warning Be sure to wait for 10 minutes or more after turning off all power supplies before disassembling work.

Step	Procedure	Procedure	Points
1	Remove the sound blanket (top upper).		
2	Remove the sound blanket (top lower).		
3	Remove the sound blanket (back).		

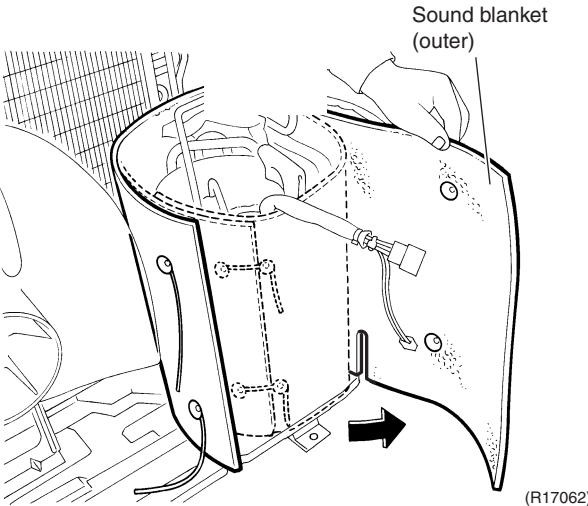
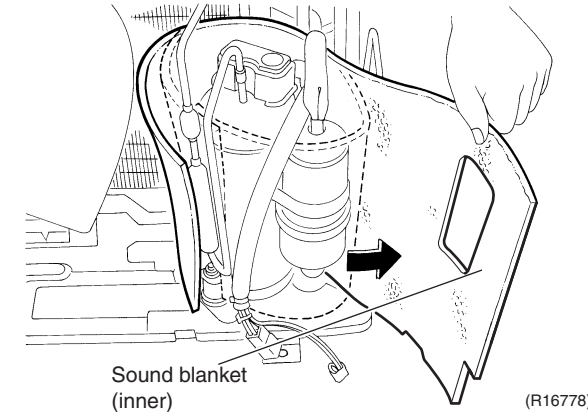
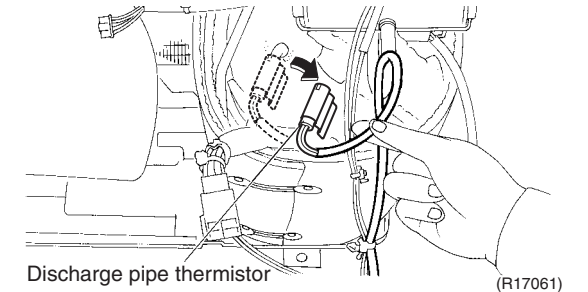
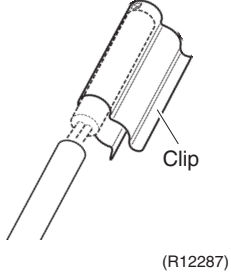
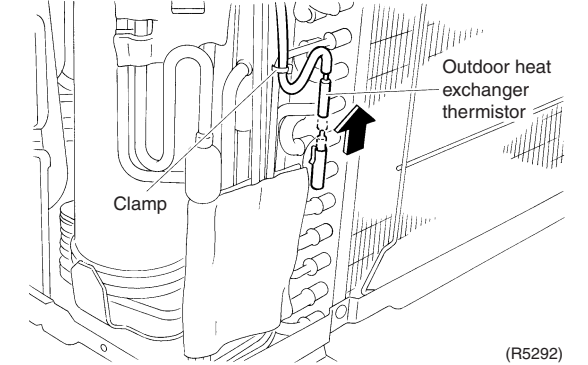
Step	Procedure	Points
4	Remove the sound blanket (outer).	<ul style="list-style-type: none"> Since the piping ports are torn easily, remove the sound blankets carefully.
		
5	Remove the sound blanket (inner).	
		
6	Release the discharge pipe thermistor.	<ul style="list-style-type: none"> Be careful not to lose the clip for the thermistor.
		
7	Cut the clamp and pull out the outdoor heat exchanger thermistor.	
		

6. Removal of Four Way Valve

Procedure

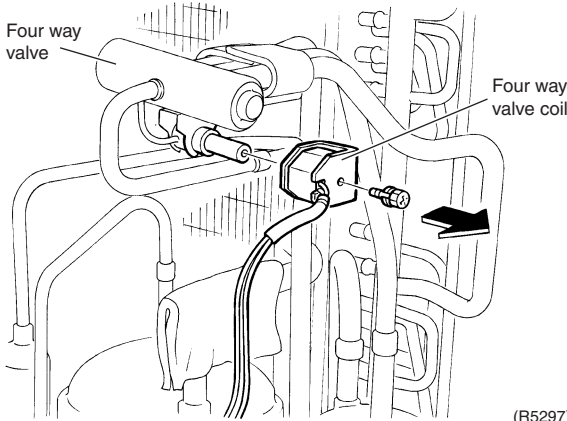
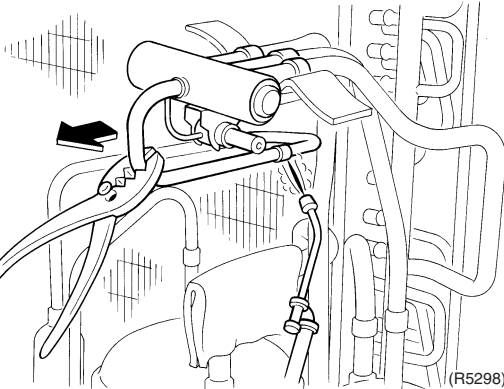
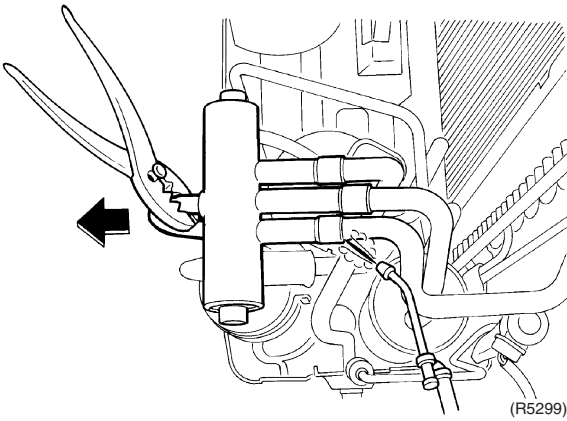

Warning Be sure to wait for 10 minutes or more after turning off all power supplies before disassembling work.

Step	Procedure	Points
1	<p>Remove the screw and remove the four way valve coil.</p>  <p>(R5297)</p>	<p>Warning Be careful not to get yourself burnt with the pipes and other parts that are heated by the gas brazing machine.</p> <p>Warning If the refrigerant gas leaks during work, ventilate the room. (If the refrigerant gas is exposed to flames, toxic gas may be generated.)</p> <p>Caution From the viewpoint of global environment protection, do not discharge the refrigerant gas in the atmosphere. Make sure to collect all the refrigerant gas.</p>
<ul style="list-style-type: none"> ■ Before working, make sure that the refrigerant gas is empty in the circuit. ■ Be sure to apply nitrogen replacement when heating up the brazed part. 	 <p>(R5298)</p>	<p>Cautions for restoration</p> <ol style="list-style-type: none"> 1. Restore the piping by non-oxidation brazing. 2. It is required to prevent the carbonization of the oil inside the four way valve and the deterioration of the gaskets affected by heat. (Keep below 120°C.) For the sake of this, wrap the four way valve with wet cloth and provide water so that the cloth does not dry.
2	<p>Heat up the brazed part of the four way valve and disconnect.</p> <p>3 Heat up every brazed part in turn and disconnect.</p>  <p>(R5299)</p>	<p>Note:</p> <ul style="list-style-type: none"> ■ Never use a metal saw to cut pipes because the sawdust may enter the circuit. ■ When withdrawing the pipes, be careful not to pinch them firmly with pliers. The pipes may get deformed. ■ Provide a protective sheet or a steel plate so that the brazing flame cannot influence peripheries.

7. Removal of Electronic Expansion Valve

Procedure

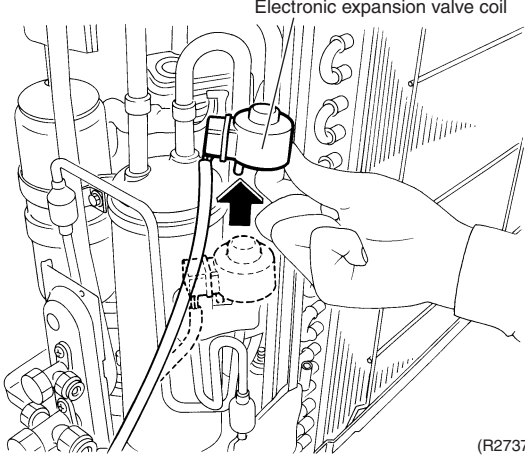
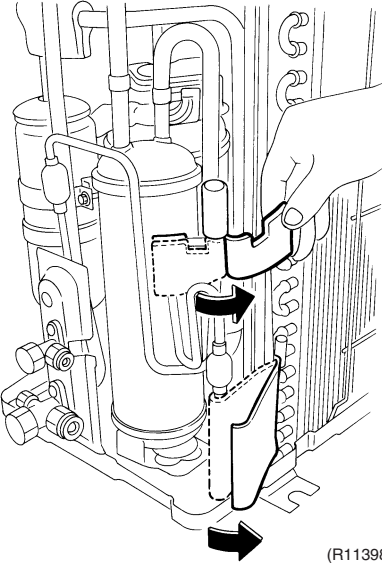
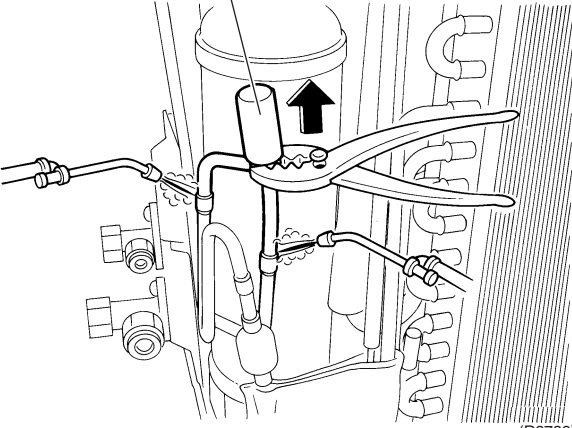

Warning Be sure to wait for 10 minutes or more after turning off all power supplies before disassembling work.

Step	Procedure	Points
1	<p>Pull out the electronic expansion valve coil.</p>  <p style="text-align: right;">(R2737)</p>	
2	<p>Remove the sheets of putty.</p>  <p style="text-align: right;">(R11398)</p>	
3	<p>Heat up the 2 brazed parts of the electronic expansion valve and remove it.</p>  <p style="text-align: right;">(R2739)</p>	<p>Warning Be careful not to get yourself burnt with the pipes and other parts that are heated by the gas brazing machine.</p> <p>Warning If the refrigerant gas leaks during work, ventilate the room. (If the refrigerant gas is exposed to flames, toxic gas may be generated.)</p> <p>Caution From the viewpoint of global environment protection, do not discharge the refrigerant gas in the atmosphere. Make sure to collect all the refrigerant gas.</p>

8. Removal of Compressor

Procedure

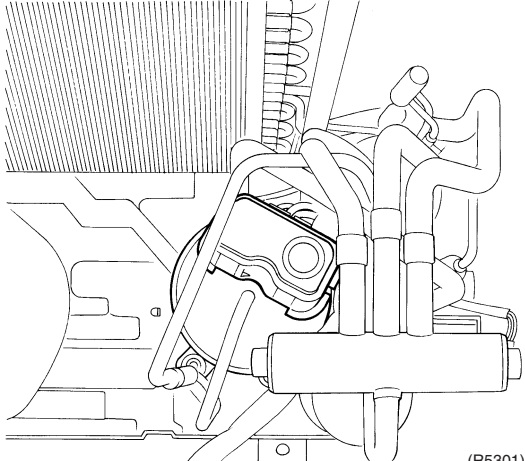
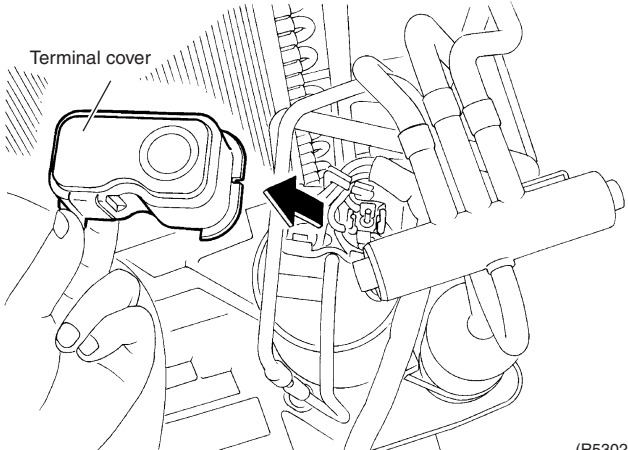
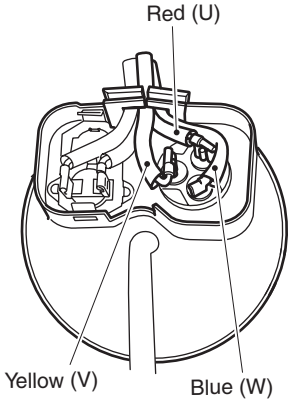

Warning Be sure to wait for 10 minutes or more after turning off all power supplies before disassembling work.

Step	Procedure	Procedure	Points
1	Remove the terminal cover.	 <p>(R5301)</p>  <p>Terminal cover</p> <p>(R5302)</p>	
2	Disconnect the lead wires of the compressor.	 <p>Red (U)</p> <p>Yellow (V)</p> <p>Blue (W)</p> <p>(R12436)</p>	

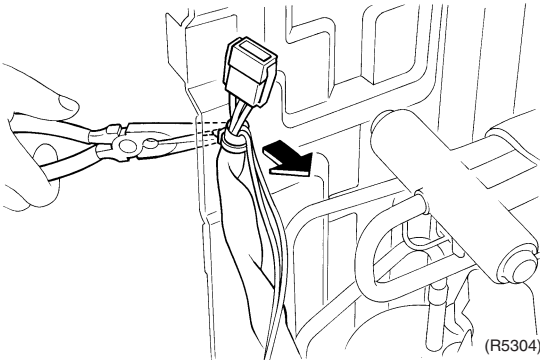
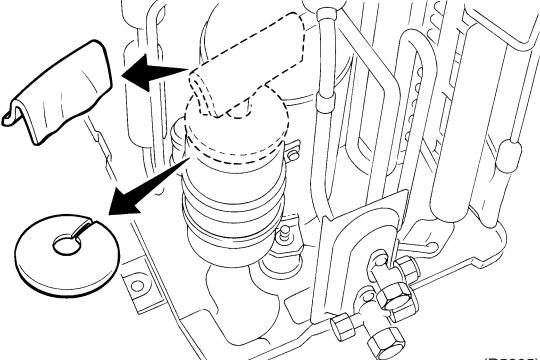
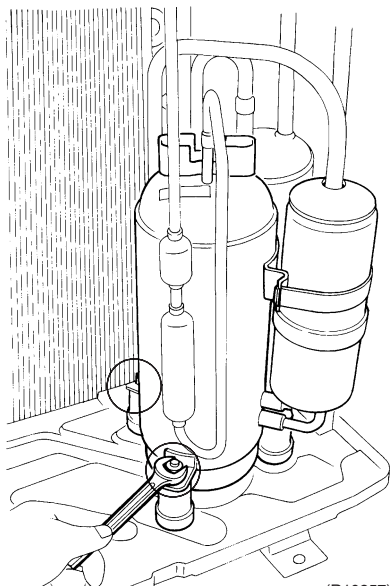
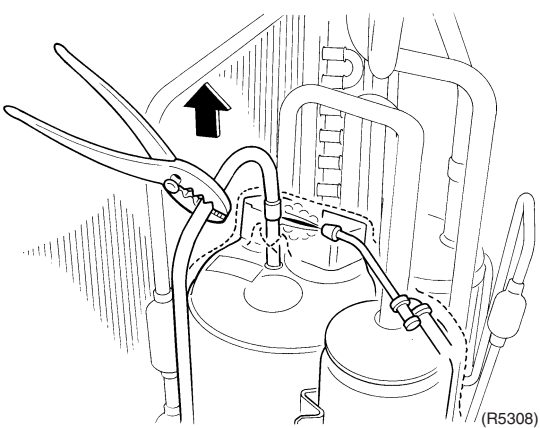
Step	Procedure	Points
3	<p>Release the clamp with pliers to detach the compressor lead wires.</p>  <p>(R5304)</p>	
4	<p>Remove the putty.</p>  <p>(R5305)</p>	
■	<p>Before working, make sure that the refrigerant gas is empty in the circuit.</p>	
■	<p>Be sure to apply nitrogen replacement when heating up the brazed part.</p>	<p>Warning Be careful not to get yourself burnt with the pipes and other parts that are heated by the gas brazing machine.</p>
5	<p>Remove the 2 nuts of the compressor.</p>  <p>(R10257)</p>	<p>Warning If the refrigerant gas leaks during work, ventilate the room. (If the refrigerant gas is exposed to flames, toxic gas may be generated.)</p>
6	<p>Heat up the brazed part of the discharge side and disconnect it.</p>  <p>(R5308)</p>	<p>Warning Since it may happen that the refrigerant oil in the compressor catches fire, prepare wet cloth so as to extinguish fire immediately.</p> <p>Caution From the viewpoint of global environment protection, do not discharge the refrigerant gas in the atmosphere. Make sure to collect all the refrigerant gas.</p>

Step	Procedure	Points
7	Heat up the brazed part of the suction side and disconnect it.	<p>Cautions for restoration</p> <ol style="list-style-type: none"> 1. Restore the piping by non-oxidation brazing. 2. It is required to prevent the carbonization of the oil inside the four way valve and the deterioration of the gaskets affected by heat. (Keep below 120°C.) For the sake of this, wrap the four way valve with wet cloth and provide water so that the cloth does not dry.
8	Lift the compressor up and remove it.	<p>In case of difficulty with gas brazing machine</p> <ol style="list-style-type: none"> 1. Disconnect the brazed part where is easy to disconnect and restore. 2. Cut pipes on the main unit with a tube cutter in order to make it easy to disconnect. <p>Note:</p> <ul style="list-style-type: none"> ■ Never use a metal saw to cut pipes because the sawdust may enter the circuit. ■ When withdrawing the pipes, be careful not to pinch them firmly with pliers. The pipes may get deformed. ■ Provide a protective sheet or a steel plate so that the brazing flame cannot influence peripheries. ■ Be careful so as not to burn the compressor terminals, the name plate, the heat exchanger fin.

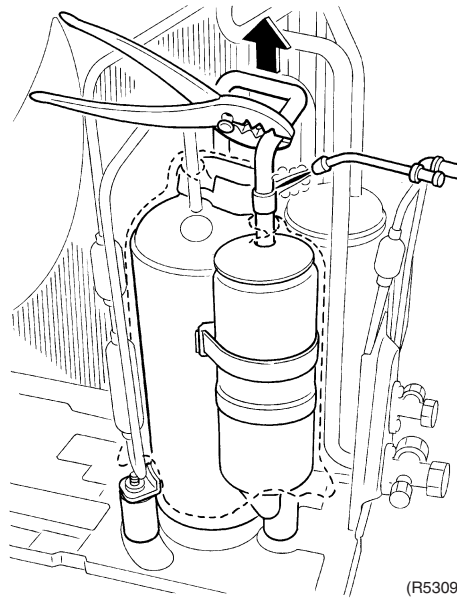

(R5309)

Revision History

Month / Year	Version	Revised contents
08/2012	Si001164	First edition

Warning



- Daikin products are manufactured for export to numerous countries throughout the world. Prior to purchase, please confirm with your local authorised importer, distributor and/or retailer whether this product conforms to the applicable standards, and is suitable for use, in the region where the product will be used. This statement does not purport to exclude, restrict or modify the application of any local legislation.
- Ask a qualified installer or contractor to install this product. Do not try to install the product yourself. Improper installation can result in water or refrigerant leakage, electrical shock, fire or explosion.
- Use only those parts and accessories supplied or specified by Daikin. Ask a qualified installer or contractor to install those parts and accessories. Use of unauthorised parts and accessories or improper installation of parts and accessories can result in water or refrigerant leakage, electrical shock, fire or explosion.
- Read the User's Manual carefully before using this product. The User's Manual provides important safety instructions and warnings. Be sure to follow these instructions and warnings.

If you have any enquiries, please contact your local importer, distributor and/or retailer.

Cautions on product corrosion

1. Air conditioners should not be installed in areas where corrosive gases, such as acid gas or alkaline gas, are produced.
2. If the outdoor unit is to be installed close to the sea shore, direct exposure to the sea breeze should be avoided. If you need to install the outdoor unit close to the sea shore, contact your local distributor.

Dealer

DAIKIN INDUSTRIES, LTD.

Head Office:
Umeda Center Bldg., 2-4-12, Nakazaki-Nishi,
Kita-ku, Osaka, 530-8323 Japan

Tokyo Office:
JR Shinagawa East Bldg., 2-18-1, Konan,
Minato-ku, Tokyo, 108-0075 Japan

http://www.daikin.com/global_ac/

©All rights reserved