

# REMOVAL PROCEDURE



SERVICE  
MANUAL

S E R V I C E M A N U A L

## 2.5/3.5 kW Class

-  Outdoor Unit
-  Inverter
-  Pair Type



# **Service Manual Removal Procedure**

## **Outdoor Unit**

### **Applicable Models**

#### **●Heat Pump**

**RXN25KEV1B**

**RXN35KEV1B**

**RXN425KC**

**RXN435KC**

# Table of Contents

1. Removal of Outer Panels .....	2
2. Removal of Outdoor Fan / Fan Motor .....	4
3. Removal of Electrical Box / PCB.....	6
4. Removal of Sound Blankets.....	14
5. Removal of Four Way Valve .....	16
6. Removal of Compressor .....	19



**Note:** ♦ The illustrations may be slightly different depending on the model.

# 1. Removal of Outer Panels

**Procedure**

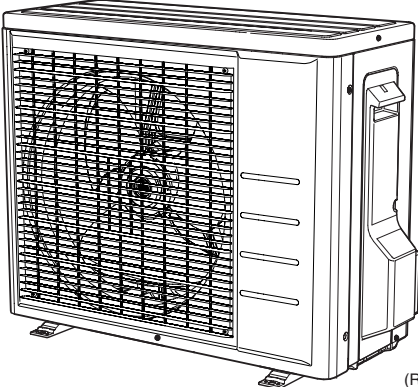
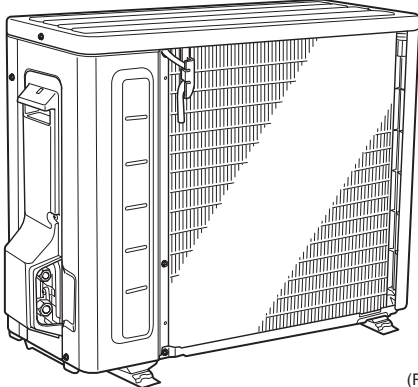
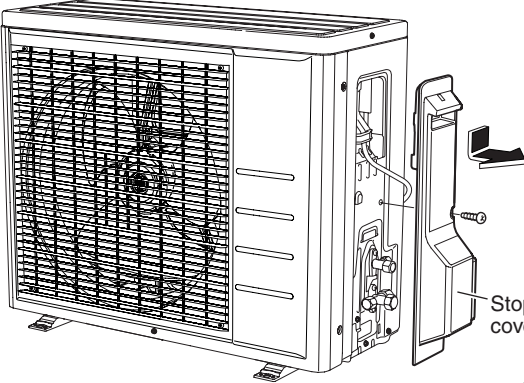
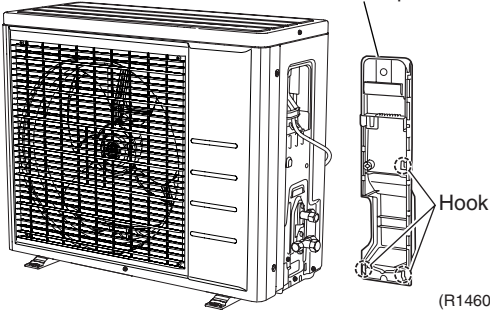

**Warning** Be sure to wait for 10 minutes or more after turning off all power supplies before disassembling work.

Step	Procedure	Points
<p>1. Appearance features</p>	 <p>(R10707)</p>  <p>(R15858)</p>	<ul style="list-style-type: none"> <li>Take care not to cut your finger by the fins of the outdoor heat exchanger.</li> </ul>
<p>2. Remove the panels.</p> <p>1 Remove the screw of the stop valve cover. Pull down the stop valve cover and remove it.</p>	 <p>(R10709)</p> <p>Stop valve cover</p>  <p>Shield plate</p> <p>Hook</p> <p>(R14606)</p>	<ul style="list-style-type: none"> <li>The stop valve cover is united with the shield plate.</li> <li>When reassembling, make sure to fit the 3 hooks.</li> </ul>

Step	Procedure	Points
2	Remove the 3 screws (right: 1 screw, left: 2 screws) and remove the top panel.	
3	Remove the 5 screws of the front panel.	
4	Lift up the left side and unfasten the hooks.	
5	Unfasten the right side hooks and remove the front panel.	
6	Remove the 4 screws of the discharge grille.	
7	Unfasten the 6 hooks and remove the discharge grille.	

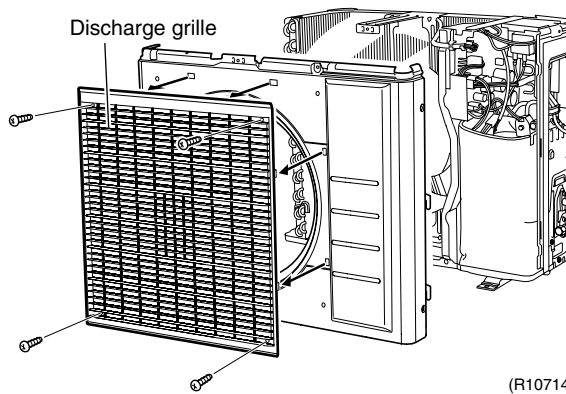
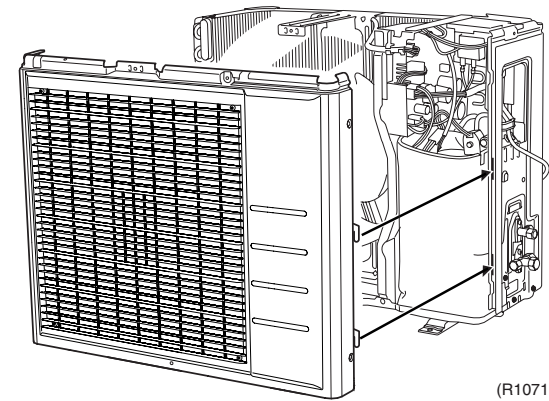
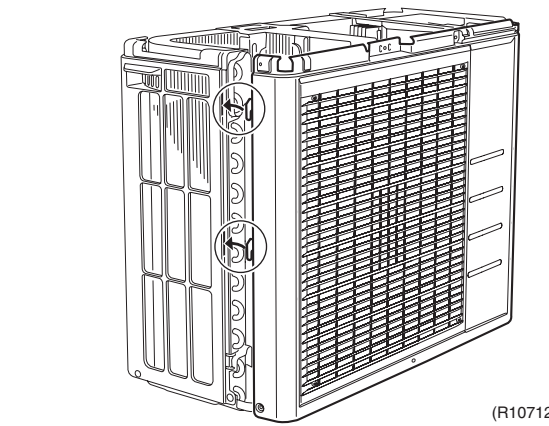
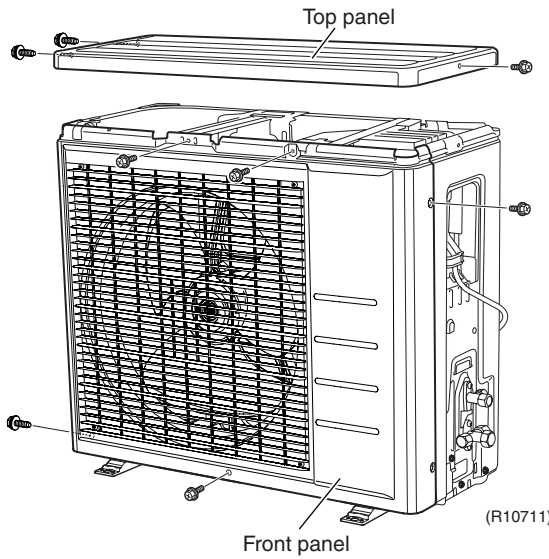

## 2. Removal of Outdoor Fan / Fan Motor

**Procedure**

**Warning** Be sure to wait for 10 minutes or more after turning off all power supplies before disassembling work.

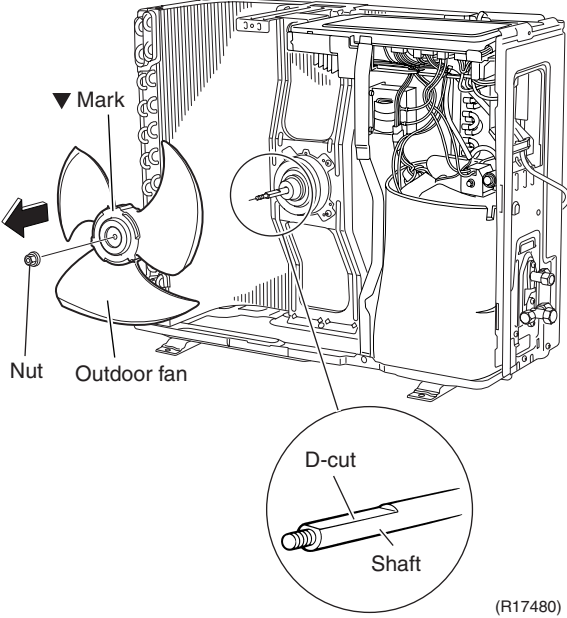
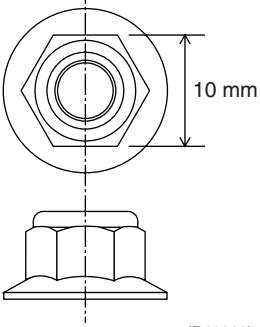
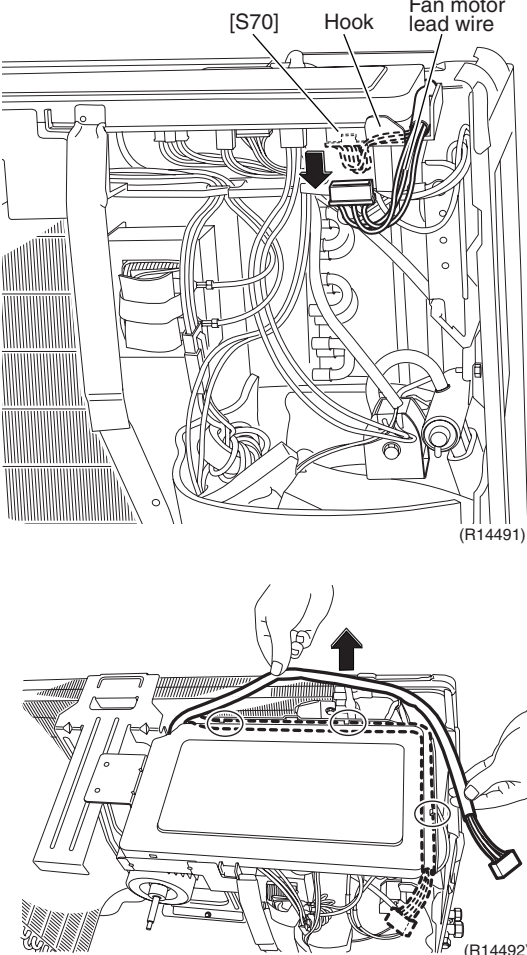
Step	Procedure	Points
<p>1. Remove the outdoor fan.</p> <p>1 Remove the nut of the outdoor fan.</p> <p>2 Remove the outdoor fan.</p>		<p><b>Preparation</b></p> <ul style="list-style-type: none"> <li>Remove the panels according to the "Removal of Outer Panels".</li> <li>Nut size: M6</li> </ul>  <ul style="list-style-type: none"> <li>When reassembling, align the ▼ mark of the outdoor fan with the D-cut section of the motor shaft.</li> </ul>
<p>2. Remove the fan motor.</p> <p>1 Disconnect the connector for the fan motor [S70].</p> <p>2 Release the fan motor lead wire from the hook.</p> <p>3 Release the fan motor lead wire from the 3 hooks.</p>		<p>[S70]: fan motor</p> <ul style="list-style-type: none"> <li>When reassembling, set the fan motor lead wire into the hook.</li> <li>When reassembling set the fan motor lead wire into the 3 hooks.</li> </ul>

Step	Procedure	Points
4	Remove the screw and remove the fan motor fixing frame.	<ul style="list-style-type: none"> <li>When reassembling, put the fan motor lead wire through the back of the fan motor so as not to be entangled with the outdoor fan.</li> </ul>
5	Release the fan motor lead wire from the hooks.	<ul style="list-style-type: none"> <li>When reassembling, set the clamped position under the lower hook of the fan motor fixing frame.</li> </ul>
6	Remove the 3 screws and remove the fan motor.	

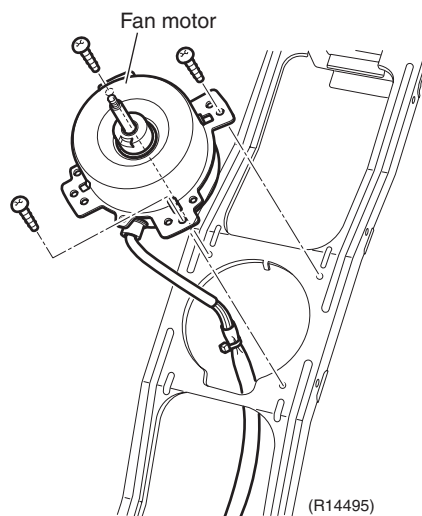
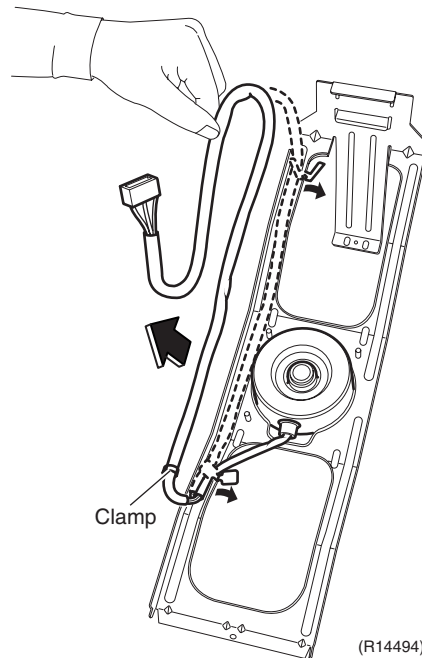
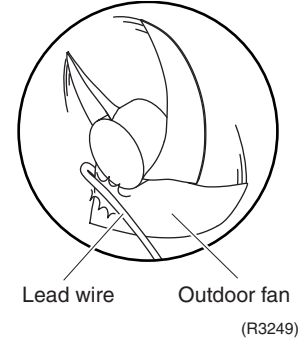
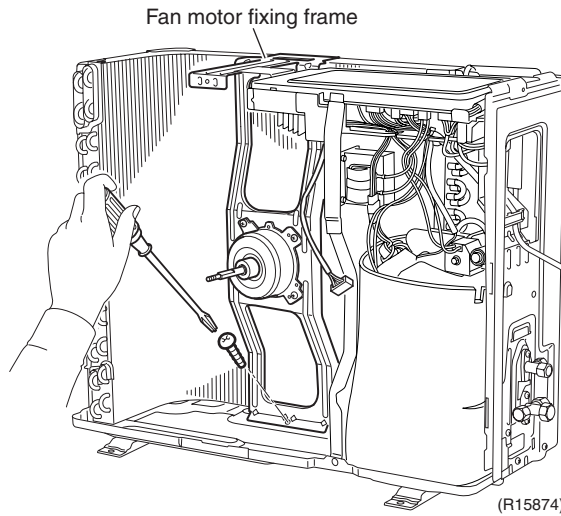

### 3. Removal of Electrical Box / PCB

**Procedure**

 **Warning** Be sure to wait for 10 minutes or more after turning off all power supplies before disassembling work.

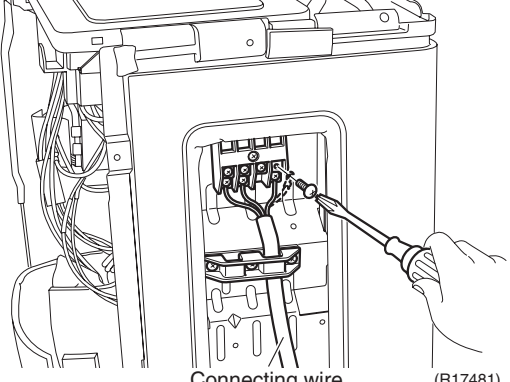
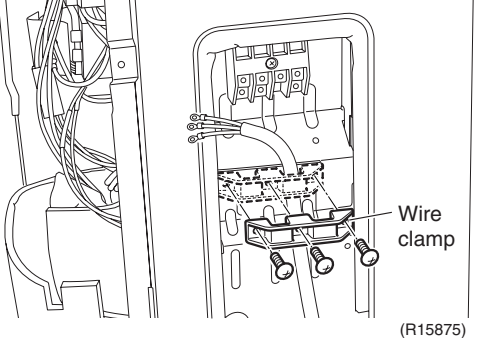
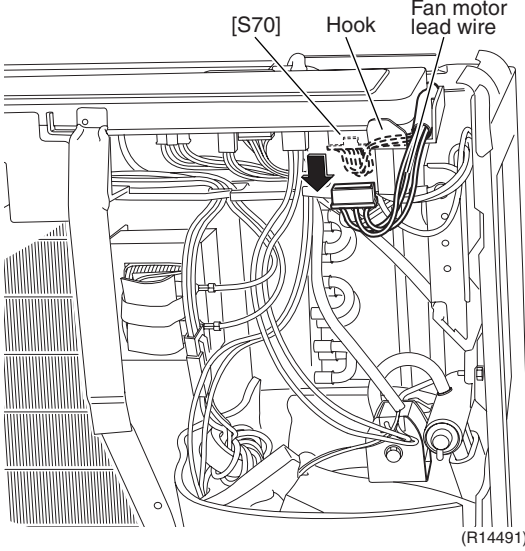
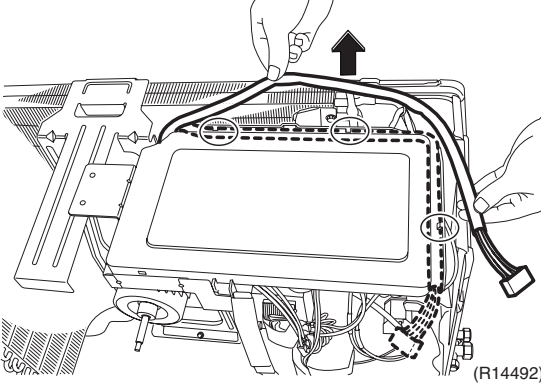
Step	Procedure	Points
1. Remove the PCB.	 <p style="text-align: center;">Connecting wire (R17481)</p>  <p style="text-align: center;">Wire clamp (R15875)</p>  <p style="text-align: center;">[S70] Hook Fan motor lead wire (R14491)</p>  <p style="text-align: center;">(R14492)</p>	<p><b>Preparation</b></p> <ul style="list-style-type: none"> <li>■ Remove the panels according to the "Removal of Outer Panels".</li> <li>■ Some models have another wiring for outdoor power-receiving system.</li> </ul> <p>[S70]: fan motor</p>
1 Remove the screws and release the connecting wire.		
2 Remove the 3 screws and remove the wire clamp.		
3 Disconnect the connector for the fan motor [S70].		
4 Release the fan motor lead wire from the hook.		
5 Release the fan motor lead wire from the 3 hooks.		

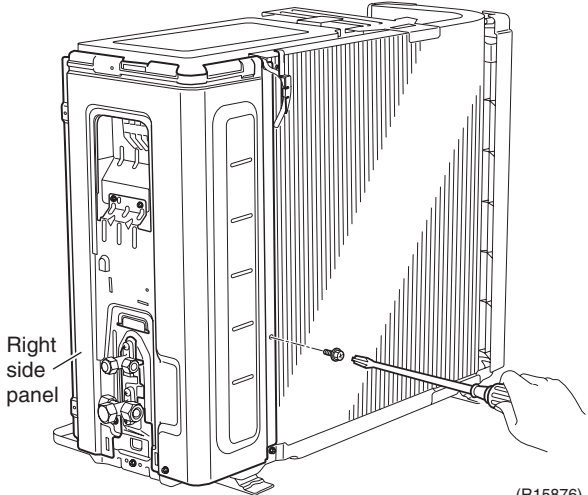
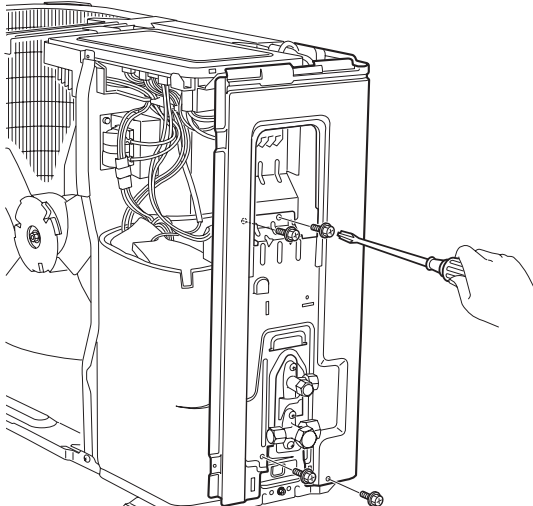
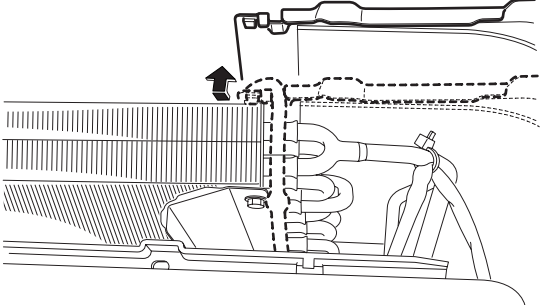
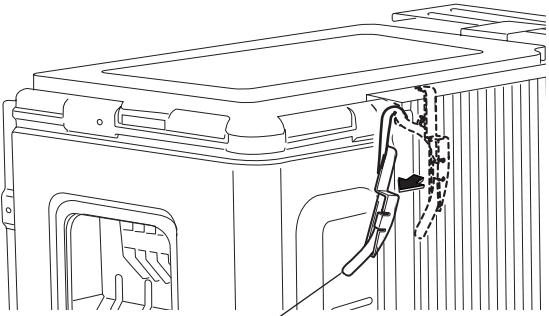

Step	Procedure	Points
6	<p>Remove the screw on the rear side of the right side panel.</p>  <p>Right side panel</p> <p>(R15876)</p>	
7	<p>Remove the 4 screws on the right side panel.</p>  <p>(R14499)</p>	
8	<p>Unfasten the hook on the rear side.</p>  <p>(R14500)</p>	<p>■ When reassembling, make sure to fit the hook.</p>
9	<p>Release the outdoor temperature thermistor from the outdoor heat exchanger.</p>  <p>Outdoor temperature thermistor</p> <p>(R16052)</p>	

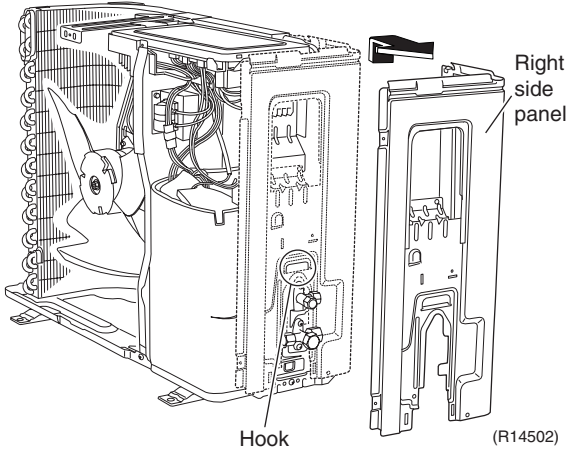
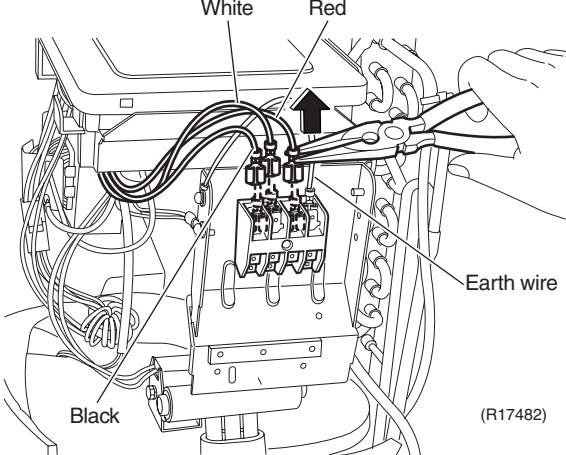
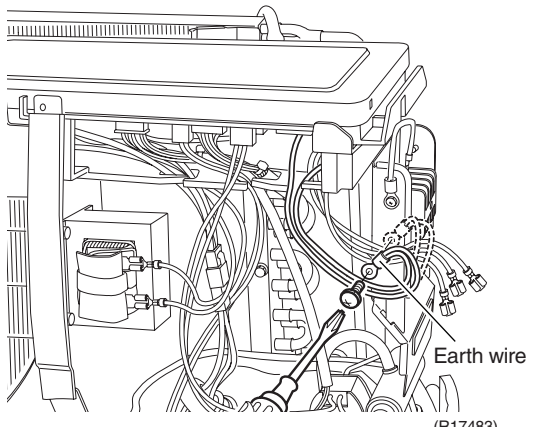
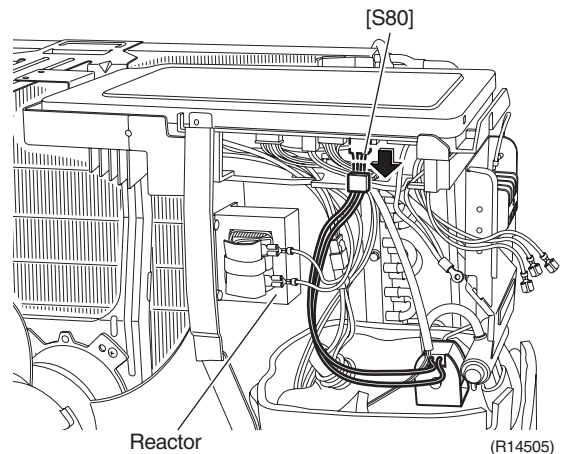
Step	Procedure	Points
10	Unfasten the hook, and remove the right side panel. 	
11	Pull out the terminals from the terminal board except the earth wire. 	1 : black, upper 2 : white, lower 3 : red, upper ⊥ : green, lower
12	Remove the screw and release the earth wire. 	
13	Disconnect the connector [S80]. 	[S80]: four way valve coil ■ The harness of the four way valve coil and the harness of the reactor cross each other.

Step	Procedure	Points
14	Disconnect the connector [S20], [S40], [S90].	[S20]: electronic expansion valve coil [S40]: overload protector [S90]: thermistors
15	Release the harnesses of [S20], [S40], [S90] from the groove.	
16	Disconnect the terminals of the reactor.	<ul style="list-style-type: none"> <li>■ The colors of the harnesses (orange or brown) do not matter to the position of the connector.</li> </ul>
17	Disconnect the relay connector of the compressor.	

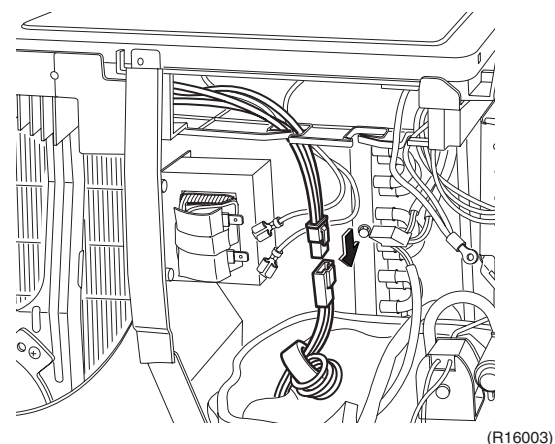
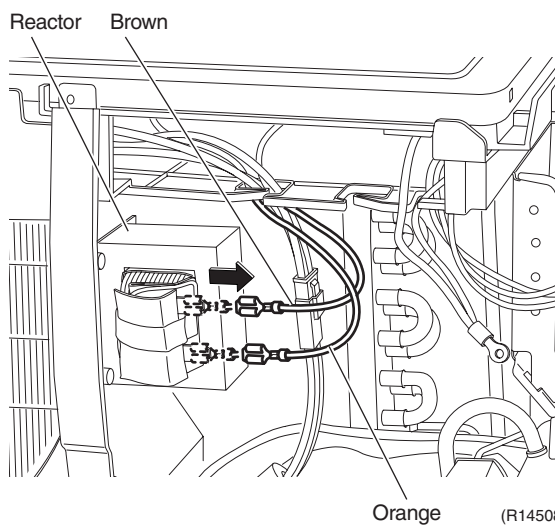
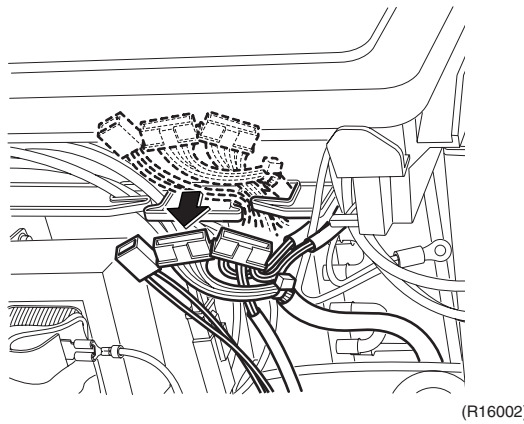
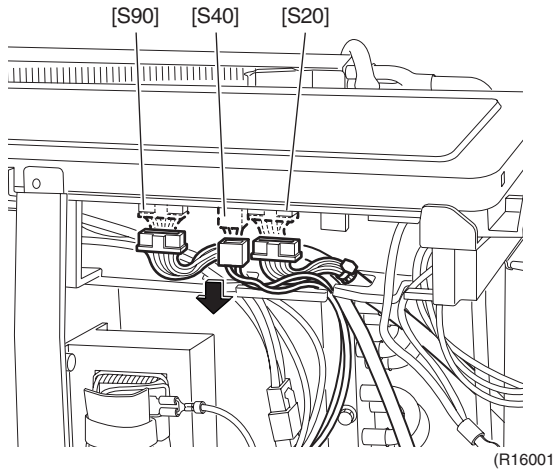

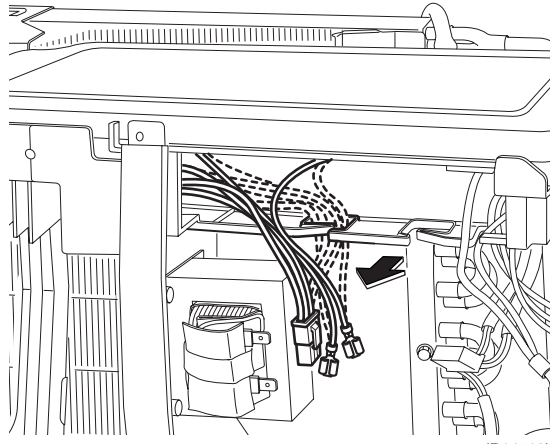
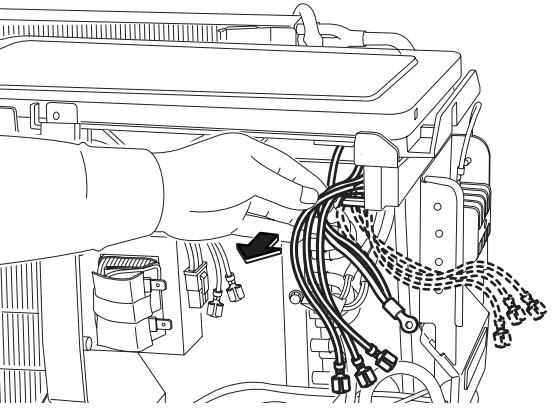
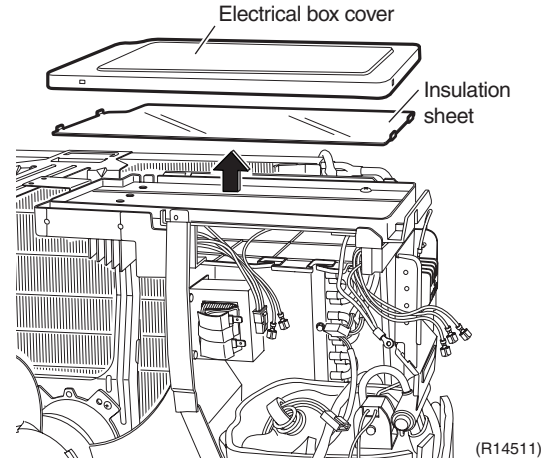
Step	Procedure	Points
18	<p>Release the harnesses of the relay connector and the reactor from the groove.</p>  <p>(R14510)</p>	
19	<p>Release the lead wires of the power supply and the earth wire from the groove.</p>  <p>(R14581)</p>	
20	<p>Remove the electrical box cover and insulation sheet.</p>  <p>(R14511)</p>	

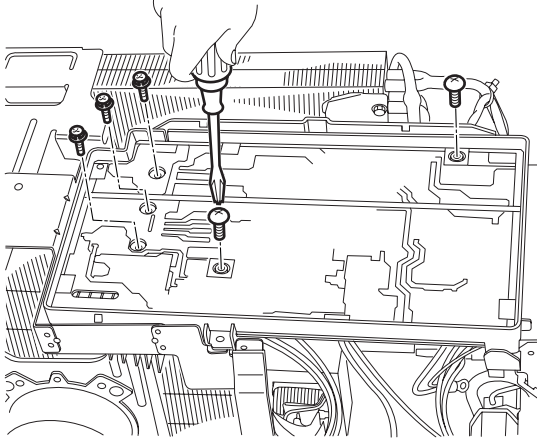
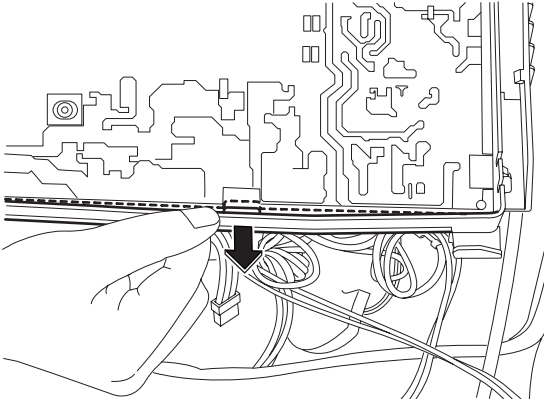
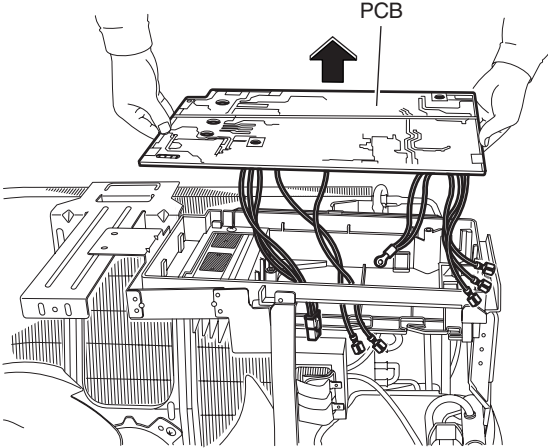
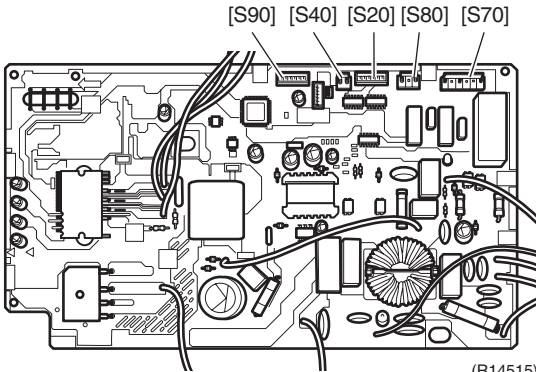
Step	Procedure	Points
21	<p>Remove the 5 screws.</p>  <p>(R14512)</p>	
22	<p>Unfasten the hook.</p>  <p>(R14513)</p>	
23	<p>Remove the PCB.</p>  <p>(R14514)</p>  <p>(R14515)</p>	<p>[S20]: electronic expansion valve coil  [S40]: overload protector  [S70]: fan motor  [S80]: four way valve coil  [S90]: thermistors</p>

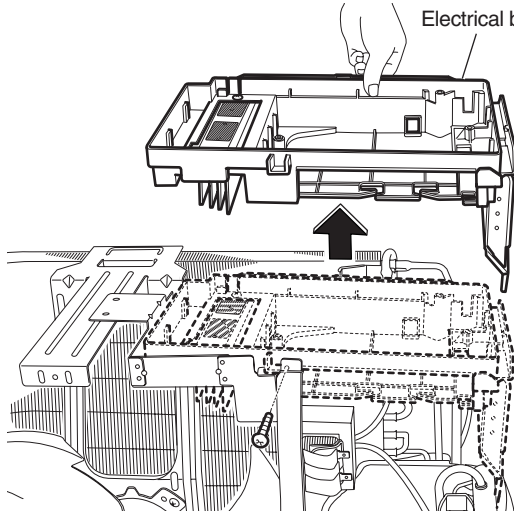
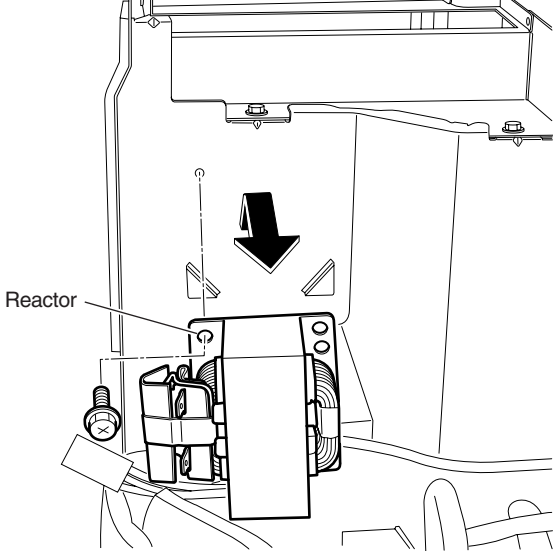
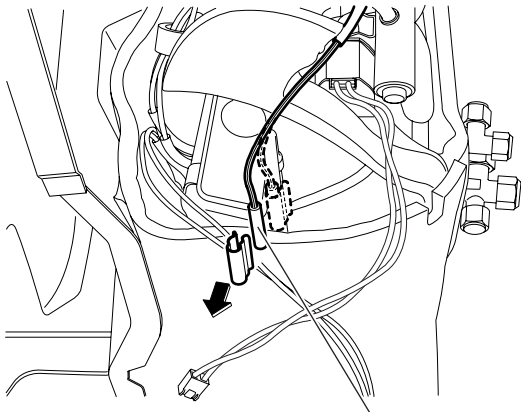
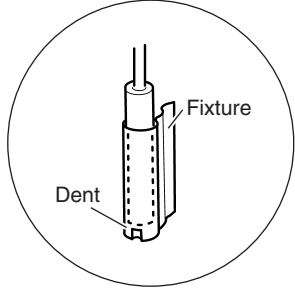
Step	Procedure	Points
<p>2. Remove the electrical box.</p> <p>1 Remove the screw and remove the electrical box.</p>	 <p>Electrical box</p> <p>(R15879)</p>	<ul style="list-style-type: none"> <li>Some models have no screw.</li> </ul>
<p>3. Remove the reactor.</p> <p>1 Remove the screw and remove the reactor.</p>	 <p>Reactor</p> <p>(R15885)</p>	<ul style="list-style-type: none"> <li>Some models have more screws.</li> </ul>
<p>4. Remove the thermistors.</p> <p>1 Release the discharge pipe thermistor.</p>	 <p>Discharge pipe thermistor</p> <p>(R14518)</p>	<ul style="list-style-type: none"> <li>Pay attention so as not to lose the fixture.</li> <li>When reassembling, do not insert the thermistor up to the dent of fixture.</li> </ul>  <p>Dent</p> <p>Fixture</p> <p>(R11740)</p>

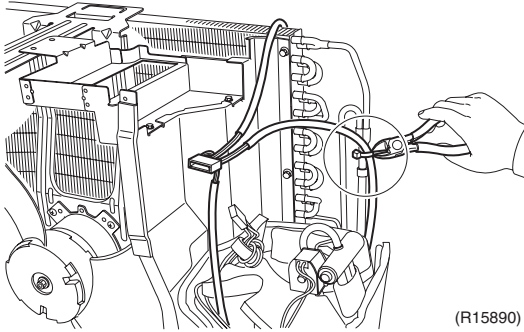
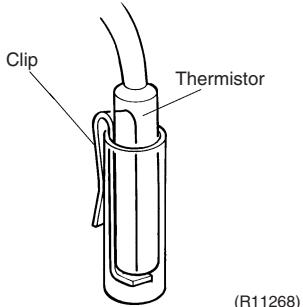
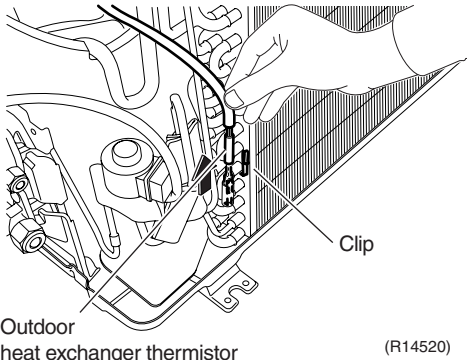
Step	Procedure	Points
2	Cut the clamp.	<ul style="list-style-type: none"> <li>■ When reassembling, clamp the outdoor heat exchanger thermistor.</li> </ul>
3	Release the outdoor heat exchanger thermistor.	<ul style="list-style-type: none"> <li>■ Take care not to lose the clip of thermistor.</li> </ul>
	 <p>(R15890)</p>	 <p>(R11268)</p>
	 <p>Outdoor heat exchanger thermistor</p> <p>Clip</p> <p>(R14520)</p>	

# 4. Removal of Sound Blankets

**Procedure**

**Warning** Be sure to wait for 10 minutes or more after turning off all power supplies before disassembling work.

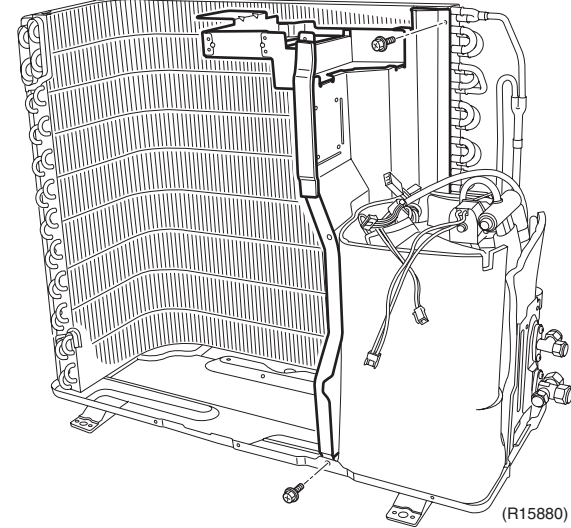
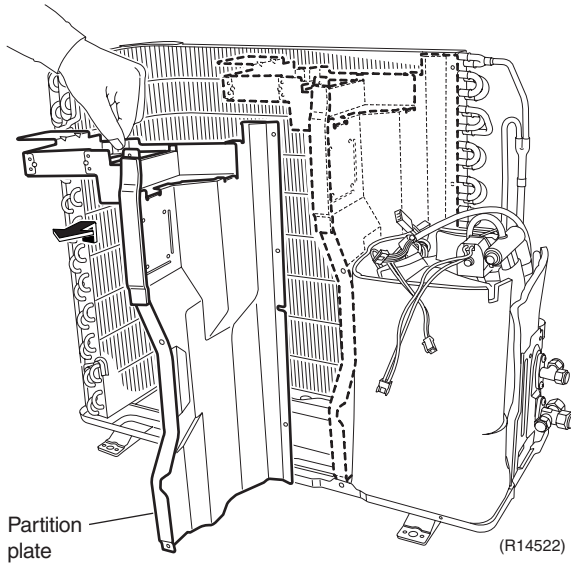
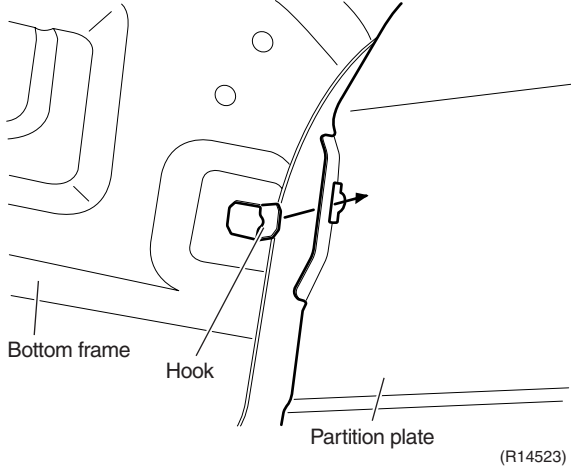
Step	Procedure	Points
1. Remove the partition plate.	 <p>(R15880)</p>	<ul style="list-style-type: none"> <li>Some models have more screws.</li> </ul>
1 Remove the 2 screws.	 <p>Partition plate</p> <p>(R14522)</p>	
2 Remove the partition plate.	 <p>Bottom frame</p> <p>Hook</p> <p>Partition plate</p> <p>(R14523)</p>	<ul style="list-style-type: none"> <li>When reassembling, fit the lower hook into the bottom frame.</li> </ul>

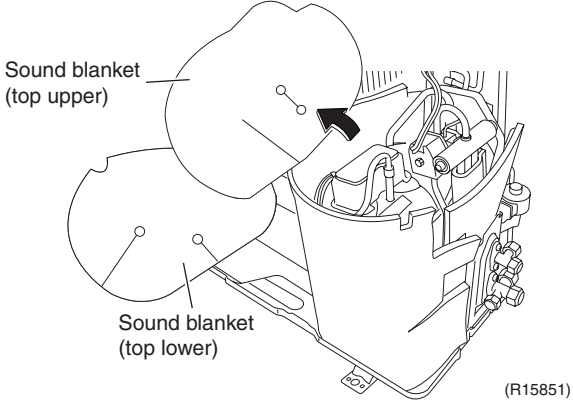
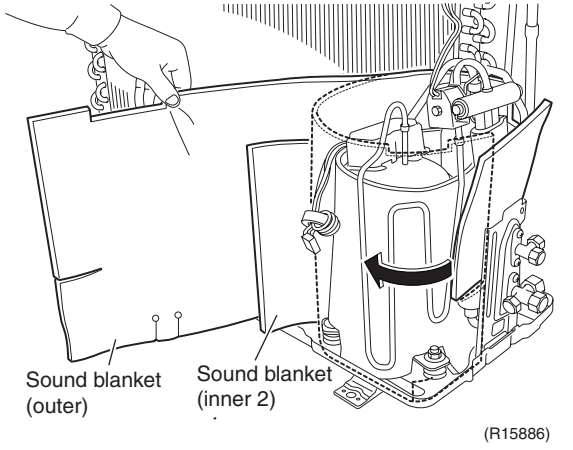
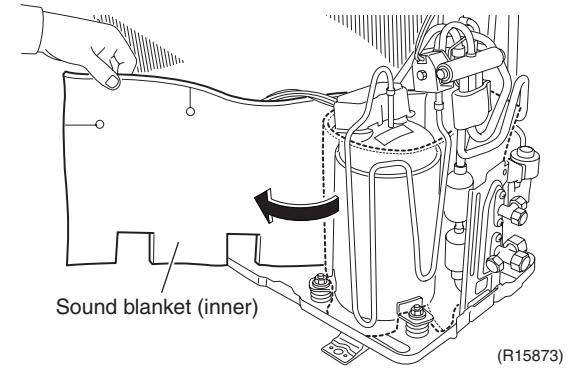

Step	Procedure	Points
2. Remove the sound blankets.		
1 Lift and remove the sound blankets (top upper, top lower).	 <p>Sound blanket (top upper)</p> <p>Sound blanket (top lower)</p> <p>(R15851)</p>	<ul style="list-style-type: none"> <li>■ The design of sound blankets is different depending on the model.</li> <li>■ Since the piping ports on the sound blanket are torn easily, remove the blanket carefully.</li> <li>■ Some models have only one sound blanket (top).</li> </ul>
2 Pull the sound blankets (outer and inner 2) out.	 <p>Sound blanket (outer)</p> <p>Sound blanket (inner 2)</p> <p>(R15886)</p>	
3 Pull the sound blanket (inner) out.	 <p>Sound blanket (inner)</p> <p>(R15873)</p>	<ul style="list-style-type: none"> <li>■ Since the piping ports on the sound blanket are torn easily, remove the blanket carefully.</li> </ul>

# 5. Removal of Four Way Valve

**Procedure**



**Warning** Be sure to wait for 10 minutes or more after turning off all power supplies before disassembling work.

Step	Procedure	Points
1.	Remove the peripheries.	
1	Remove the screw and remove the four way valve coil.	
<p>Four way valve coil (R14527)</p>		
2	Remove the terminal cover.	
<p>(R14528)</p>		
3	Disconnect the terminals of the compressor.	
4	Remove the overload protector.	
<p>(R14529)</p>		

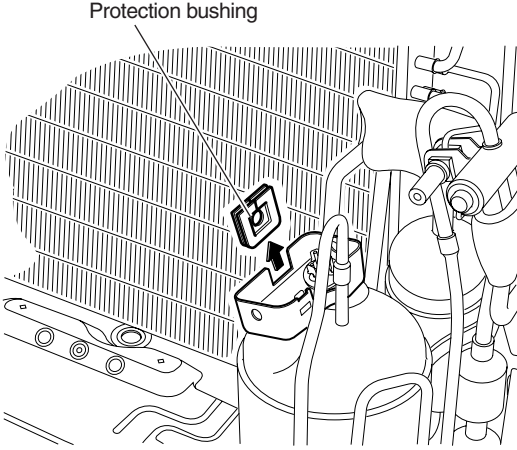
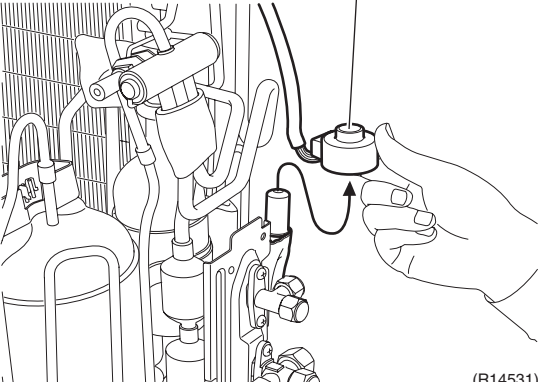
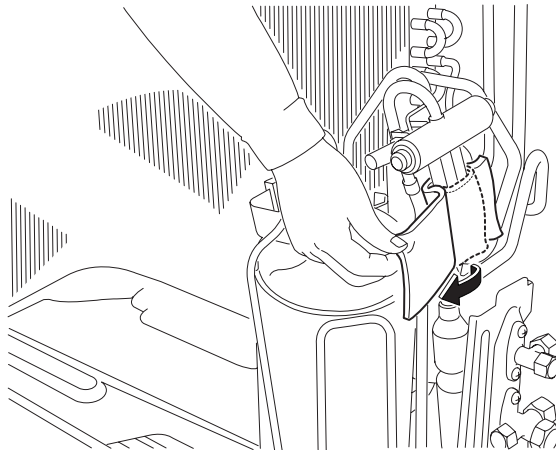
Step	Procedure	Points
5	<p>Remove the protection bushing.</p>  <p style="text-align: right;">(R14530)</p>	
6	<p>Remove the electronic expansion valve coil.</p>  <p style="text-align: right;">(R14531)</p>	
7	<p>Remove the putty.</p>  <p style="text-align: right;">(R14532)</p>	

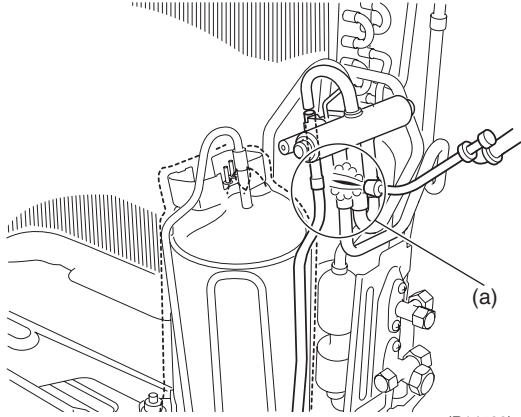
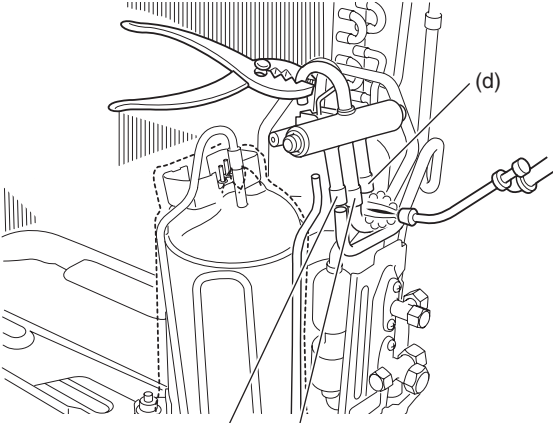
Step	Procedure	Points
<ul style="list-style-type: none"> <li>■ Before working, make sure that the refrigerant gas is empty in the circuit.</li> <li>■ Be sure to apply nitrogen replacement when heating up the brazed part.</li> </ul>	 <p style="text-align: right;">(R14533)</p>	<p><b>Warning</b> Be careful not to get yourself burnt with the pipes and other parts that are heated by the gas brazing machine.</p>
2. Remove the four way valve.		
1	Heat up the brazed point (a) and withdraw the piping with pliers.	
2	Heat up the 3 brazed points of the four way valve. Disconnect the point (b) first.	
3	Disconnect the points (c) and (d).	
<b>Note:</b>	 <p style="text-align: right;">(R14534)</p>	<p><b>Caution</b> From the viewpoint of global environment protection, do not discharge the refrigerant gas in the atmosphere. Make sure to collect all the refrigerant gas.</p>
<ul style="list-style-type: none"> <li>■ Do not use a metal saw for cutting pipes by all means because the sawdust comes into the circuit.</li> </ul>		<p><b>Cautions for restoration</b></p> <ol style="list-style-type: none"> <li>1. Restore the piping by non-oxidation brazing.</li> <li>2. It is required to prevent the carbonization of the oil inside the four way valve and the deterioration of the gaskets affected by heat. (Keep below 120°C.) For the sake of this, wrap the four way valve with wet cloth and provide water so that the cloth does not dry.</li> </ol>
<ul style="list-style-type: none"> <li>■ When withdrawing the pipes, be careful not to pinch them firmly with pliers. The pipes may get deformed.</li> </ul>		
<ul style="list-style-type: none"> <li>■ Provide a protective sheet or a steel plate so that the brazing flame cannot influence peripheries.</li> </ul>		<p><b>In case of difficulty with gas brazing machine</b></p> <ol style="list-style-type: none"> <li>1. Disconnect the brazed part where is easy to disconnect and restore.</li> <li>2. Cut pipes on the main unit with a tube cutter in order to make it easy to disconnect.</li> </ol>

# 6. Removal of Compressor

**Procedure**

**Warning** Be sure to wait for 10 minutes or more after turning off all power supplies before disassembling work.

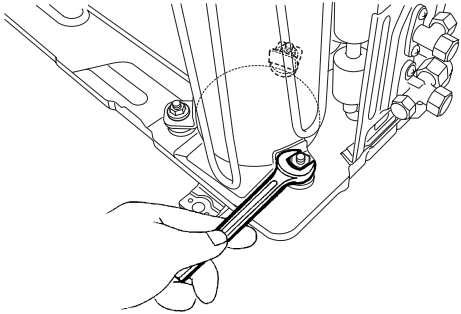
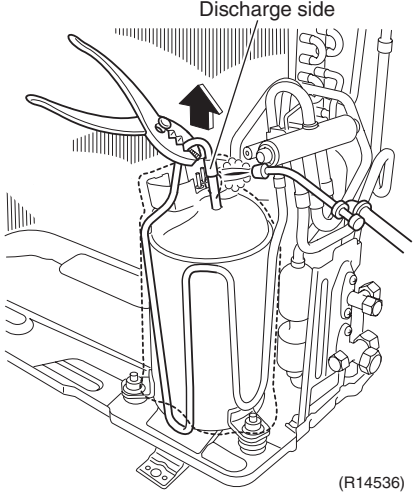
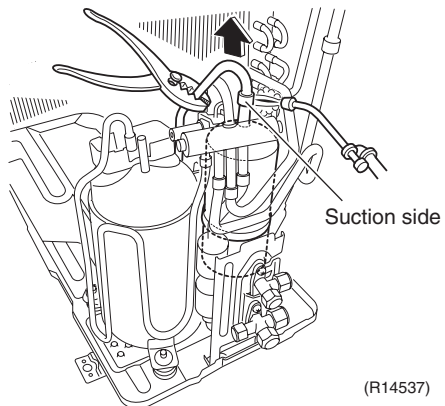
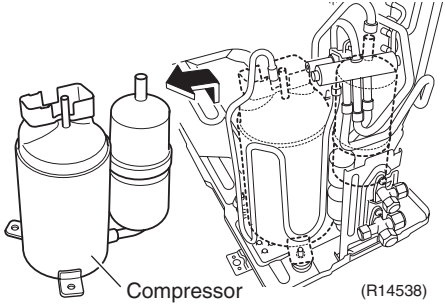
Step	Procedure	Points
<p>1 Remove the four way valve, the terminal cover and disconnect the terminals of the compressor so as not to burn them.</p> <p>2 Remove the 3 nuts of the compressor.</p>	 <p>(R14535)</p>	<p><b>Warning</b> Be careful not to get yourself burnt with the pipes and other parts that are heated by the gas brazing machine.</p> <p><b>Warning</b> If the refrigerant gas leaks during work, ventilate the room. (If the refrigerant gas is exposed to flames, toxic gas may be generated.)</p>
<ul style="list-style-type: none"> <li>■ Before working, make sure that the refrigerant gas is empty in the circuit.</li> <li>■ Be sure to apply nitrogen replacement when heating up the brazed part.</li> </ul>	 <p>(R14536)</p>	<p><b>Warning</b> Since it may happen that the refrigerant oil in the compressor catches fire, prepare wet cloth so as to extinguish fire immediately.</p>
<p>3 Heat up the brazed part of the discharge side and disconnect.</p> <p>4 Heat up the brazed part of the suction side and disconnect.</p> <p>5 Lift the compressor up and remove it.</p>	 <p>(R14537)</p>	<p><b>Caution</b> From the viewpoint of global environment protection, do not discharge the refrigerant gas in the atmosphere. Make sure to collect all the refrigerant gas.</p>
<p><b>Note:</b></p> <ul style="list-style-type: none"> <li>■ Do not use a metal saw for cutting pipes by all means because the sawdust comes into the circuit.</li> <li>■ When withdrawing the pipes, be careful not to pinch them firmly with pliers. The pipes may get deformed.</li> <li>■ Provide a protective sheet or a steel plate so that the brazing flame cannot influence peripheries.</li> <li>■ Be careful so as not to burn the compressor terminals, the name plate, the heat exchanger fin.</li> </ul>	 <p>(R14538)</p>	<p><b>Cautions for restoration</b></p> <ol style="list-style-type: none"> <li>1. Restore the piping by non-oxidation brazing.</li> <li>2. It is required to prevent the carbonization of the oil inside the four way valve and the deterioration of the gaskets affected by heat. (Keep below 120°C.) For the sake of this, wrap the four way valve with wet cloth and provide water so that the cloth does not dry.</li> </ol> <p><b>In case of difficulty with gas brazing machine</b></p> <ol style="list-style-type: none"> <li>1. Disconnect the brazed part where is easy to disconnect and restore.</li> <li>2. Cut pipes on the main unit with a tube cutter in order to make it easy to disconnect.</li> </ol>

# Revision History

Month / Year	Version	Revised contents
08/2012	Si001161	First edition

Warning



- Daikin products are manufactured for export to numerous countries throughout the world. Prior to purchase, please confirm with your local authorised importer, distributor and/or retailer whether this product conforms to the applicable standards, and is suitable for use, in the region where the product will be used. This statement does not purport to exclude, restrict or modify the application of any local legislation.
- Ask a qualified installer or contractor to install this product. Do not try to install the product yourself. Improper installation can result in water or refrigerant leakage, electrical shock, fire or explosion.
- Use only those parts and accessories supplied or specified by Daikin. Ask a qualified installer or contractor to install those parts and accessories. Use of unauthorised parts and accessories or improper installation of parts and accessories can result in water or refrigerant leakage, electrical shock, fire or explosion.
- Read the User's Manual carefully before using this product. The User's Manual provides important safety instructions and warnings. Be sure to follow these instructions and warnings.

If you have any enquiries, please contact your local importer, distributor and/or retailer.

### Cautions on product corrosion

1. Air conditioners should not be installed in areas where corrosive gases, such as acid gas or alkaline gas, are produced.
2. If the outdoor unit is to be installed close to the sea shore, direct exposure to the sea breeze should be avoided. If you need to install the outdoor unit close to the sea shore, contact your local distributor.

### Dealer

### **DAIKIN INDUSTRIES, LTD.**

Head Office:  
Umeda Center Bldg., 2-4-12, Nakazaki-Nishi,  
Kita-ku, Osaka, 530-8323 Japan

Tokyo Office:  
JR Shinagawa East Bldg., 2-18-1, Konan,  
Minato-ku, Tokyo, 108-0075 Japan

[http://www.daikin.com/global\\_ac/](http://www.daikin.com/global_ac/)

©All rights reserved