

REMOVAL PROCEDURE



S E R V I C E M A N U A L

2.5/3.2/3.5 kW Class

-  Outdoor Unit
-  Inverter
-  Pair Type



Service Manual Removal Procedure

Outdoor Unit

Applicable Models

●Heat Pump

**RXS225KC
RXS232KC**

**RXS225KCG
RXS232KCG**

**RXS225KCP
RXS232KCP**

**RXS225KCS
RXS232KCS**

**RXB325KC
RXB335KC**

Table of Contents

| | |
|---|----|
| 1. Removal of Outer Panels | 2 |
| 2. Removal of Outdoor Fan / Fan Motor | 4 |
| 3. Removal of Electrical Box / PCBs | 6 |
| 4. Removal of Sound Blankets | 14 |
| 5. Removal of Four Way Valve | 16 |
| 6. Removal of Compressor | 19 |



Note: ♦ The illustrations may be slightly different depending on the model.

1. Removal of Outer Panels

Procedure

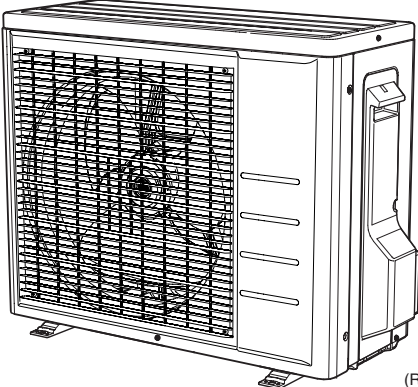
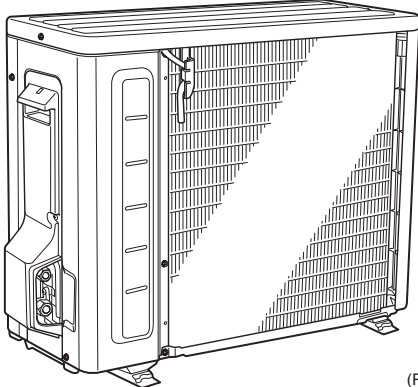
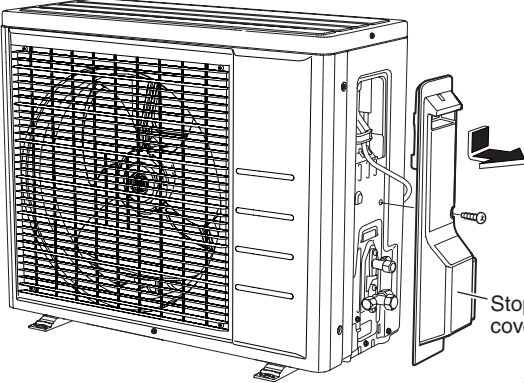
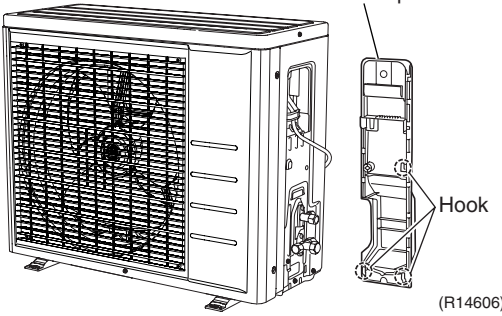

Warning Be sure to wait for 10 minutes or more after turning off all power supplies before disassembling work.

| Step | Procedure | Points |
|---|---|---|
| <p>1. Appearance features</p> |  <p>(R10707)</p>  <p>(R15858)</p> | <ul style="list-style-type: none"> ■ Take care not to cut your finger by the fins of the outdoor heat exchanger. |
| <p>2. Remove the panels.</p> <p>1 Remove the screw of the stop valve cover. Pull down the stop valve cover and remove it.</p> |  <p>(R10709)</p> <p>Stop valve cover</p>  <p>(R14606)</p> <p>Shield plate</p> <p>Hook</p> | <ul style="list-style-type: none"> ■ The stop valve cover is united with the shield plate. ■ When reassembling, make sure to fit the 3 hooks. |

| Step | Procedure | Points |
|------|--|--------|
| 2 | Remove the 3 screws (right: 1 screw, left: 2 screws) and remove the top panel. | |
| 3 | Remove the 5 screws of the front panel. | |
| 4 | Lift up the left side and unfasten the hooks. | |
| 5 | Unfasten the right side hooks and remove the front panel. | |
| 6 | Remove the 4 screws of the discharge grille. | |
| 7 | Unfasten the 6 hooks and remove the discharge grille. | |

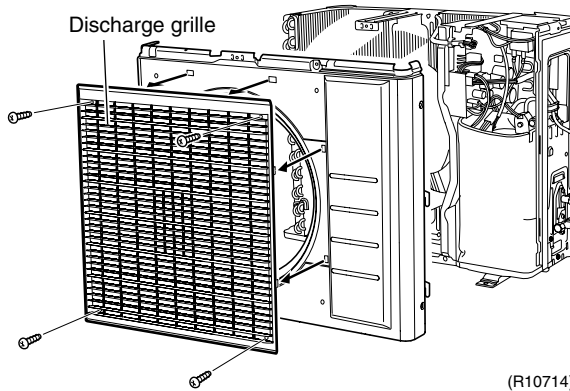
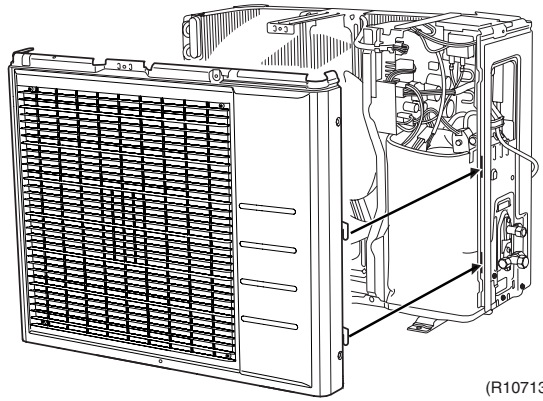
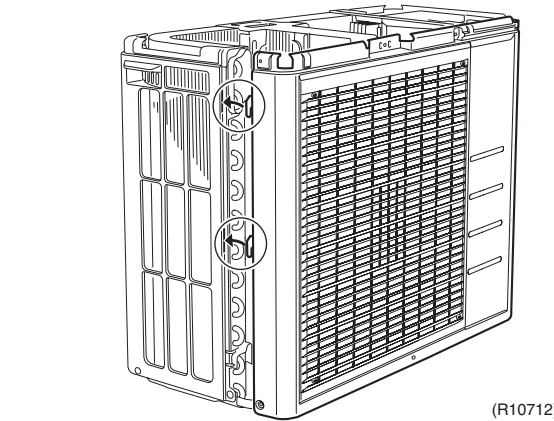
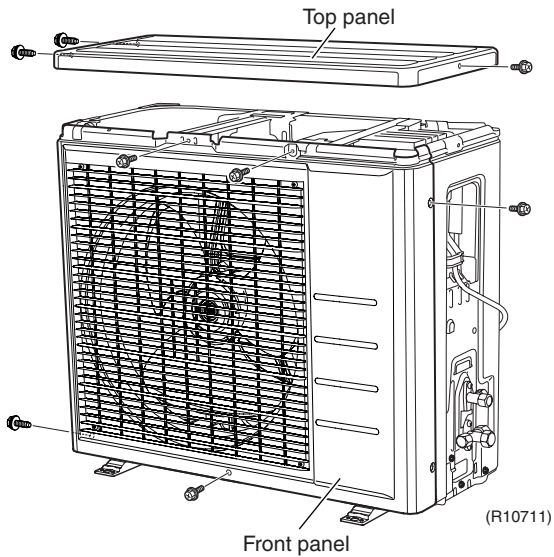

2. Removal of Outdoor Fan / Fan Motor

Procedure



Warning Be sure to wait for 10 minutes or more after turning off all power supplies before disassembling work.

| Step | Procedure | Points |
|--|-----------|---|
| <p>1. Remove the outdoor fan.</p> <p>1 Remove the nut of the outdoor fan.</p> <p>2 Remove the outdoor fan.</p> | | <p>Preparation</p> <ul style="list-style-type: none"> Remove the panels according to the "Removal of Outer Panels". Nut size: M6 <p>(R12236)</p> <ul style="list-style-type: none"> When reassembling, align the ▼ mark of the outdoor fan with the D-cut section of the motor shaft. |
| <p>2. Remove the fan motor.</p> <p>1 Disconnect the connector for the fan motor [S70].</p> <p>2 Release the fan motor lead wire from the hooks.</p> <p>3 Remove the screw and remove the fan motor fixing frame.</p> | | |

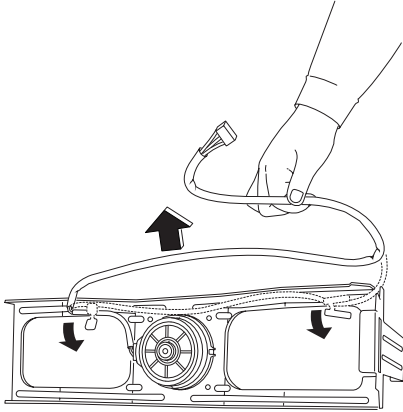
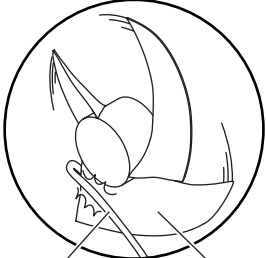
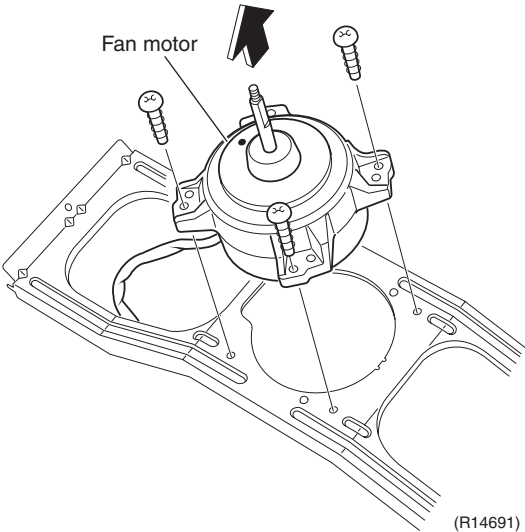
| Step | Procedure | Points | |
|------|--|--|--|
| 4 | <p>Release the fan motor lead wire from the hooks.</p> |  <p>(R14724)</p> | <ul style="list-style-type: none"> When reassembling, put the fan motor lead wire through the back of the fan motor so as not to be entangled with the outdoor fan.  <p>Lead wire Outdoor fan (R3249)</p> |
| 5 | <p>Remove the 3 screws and remove the fan motor.</p> |  <p>Fan motor</p> <p>(R14691)</p> | |

3. Removal of Electrical Box / PCBs

Procedure

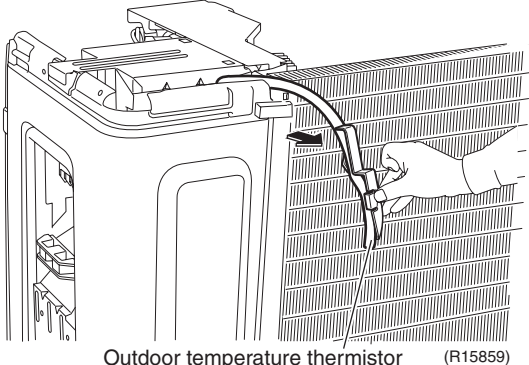
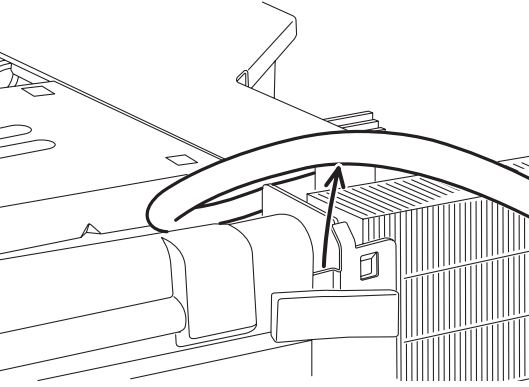
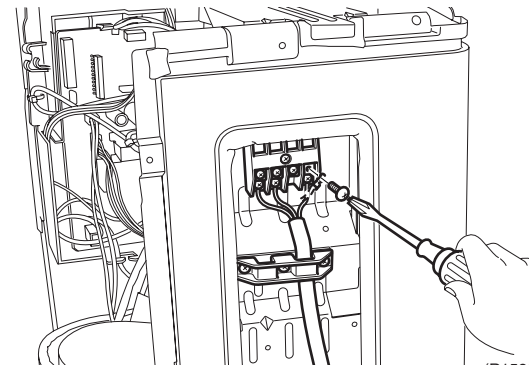
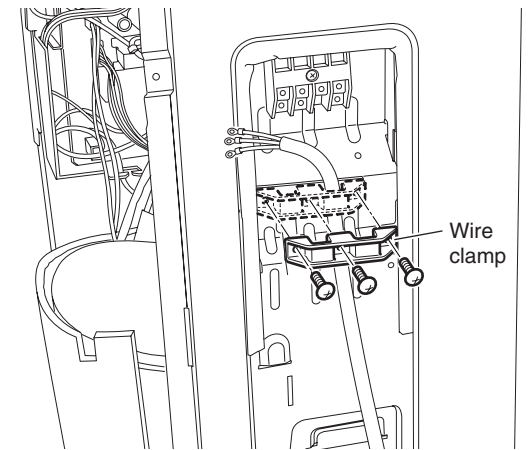

Warning Be sure to wait for 10 minutes or more after turning off all power supplies before disassembling work.

| Step | Procedure | Points |
|---|---|---|
| 1. Remove the right side panel. |  <p>Outdoor temperature thermistor (R15859)</p> | <p>Preparation</p> <ul style="list-style-type: none"> Remove the panels according to the "Removal of Outer Panels". |
| 1 Unhook the outdoor temperature thermistor. |  <p>(R14781)</p> | |
| 2 Release the outdoor temperature thermistor from the groove. |  <p>(R15860)</p> | |
| 3 Remove the screws and release the connecting wires. |  <p>Wire clamp</p> <p>(R14783)</p> | |
| 4 Remove the 3 screws and remove the wire clamp. | | |

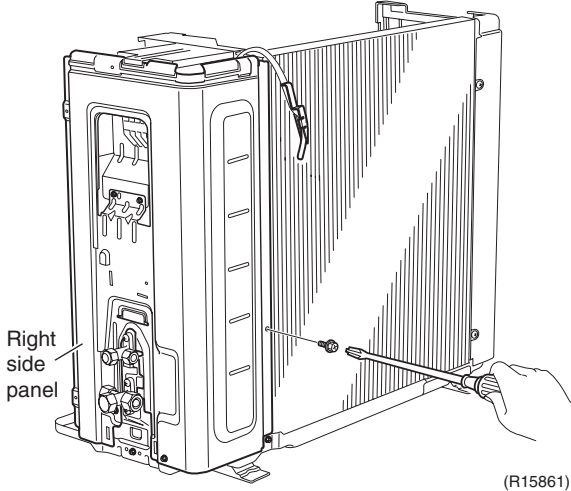
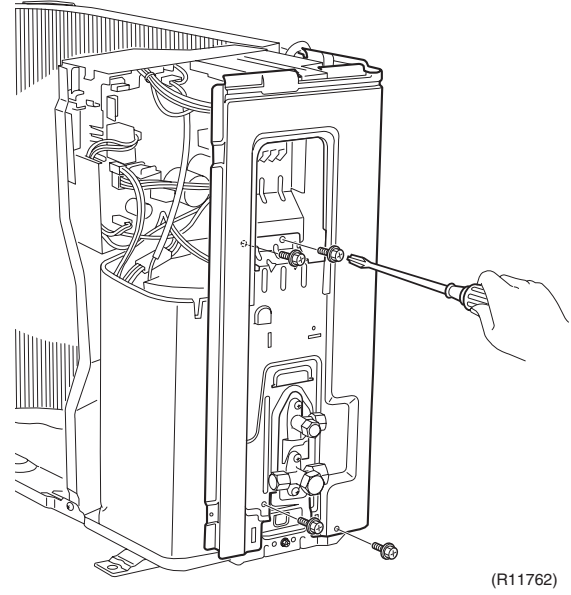
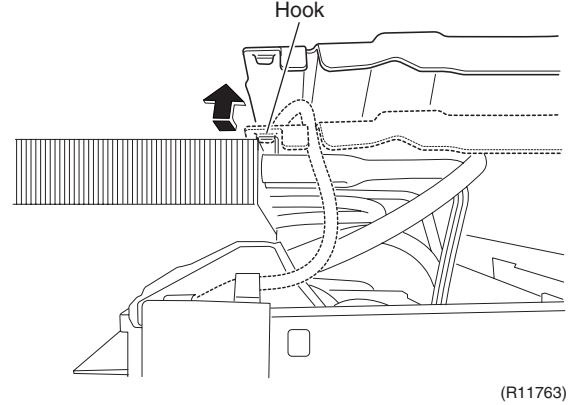
| Step | Procedure | Points |
|------|--|--|
| 5 | <p>Remove the screw on the rear side of the right side panel.</p>  <p>(R15861)</p> | |
| 6 | <p>Remove the 4 screws on the right side panel.</p>  <p>(R11762)</p> | |
| 7 | <p>Unfasten the hook on the rear side.</p>  <p>(R11763)</p> | <p>■ When reassembling, make sure to fit the hook.</p> |

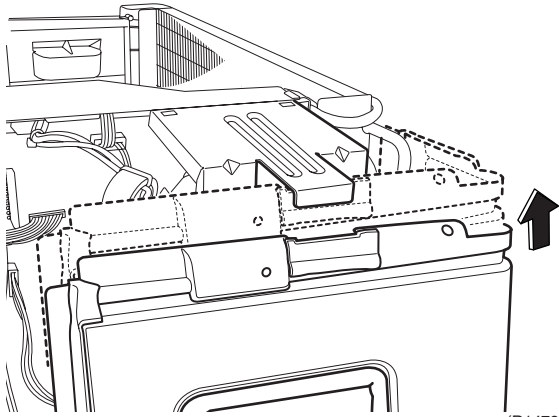
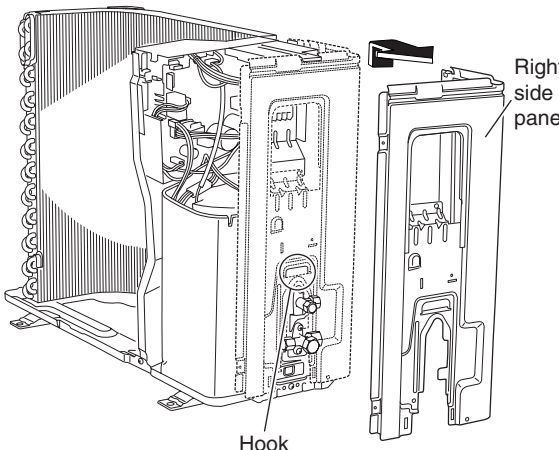
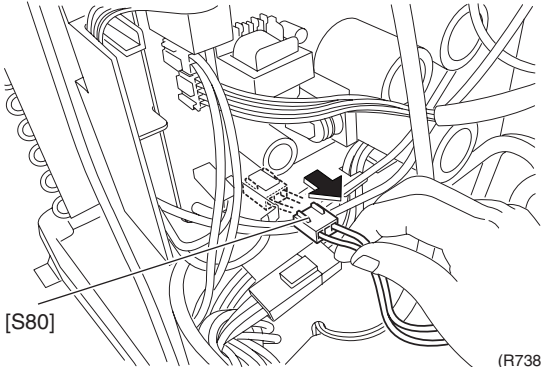
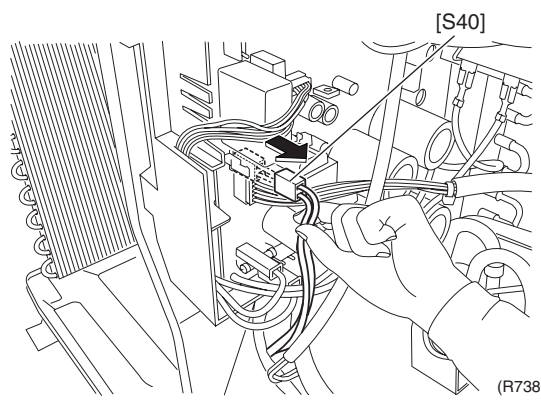
| Step | Procedure | Points |
|-------------------------------|--|--------|
| 8 | <p>Unfasten the hook above the electrical box.</p>  <p>(R14787)</p> | |
| 9 | <p>Unfasten the hook, and remove the right side panel.</p>  <p>Hook</p> <p>Right side panel</p> <p>(R11764)</p> | |
| 2. Remove the electrical box. | | |
| 1 | <p>Disconnect the connector for the four way valve coil [S80].</p>  <p>[S80]</p> <p>(R7388)</p> | |
| 2 | <p>Disconnect the connector for the overload protector [S40].</p>  <p>[S40]</p> <p>(R7389)</p> | |

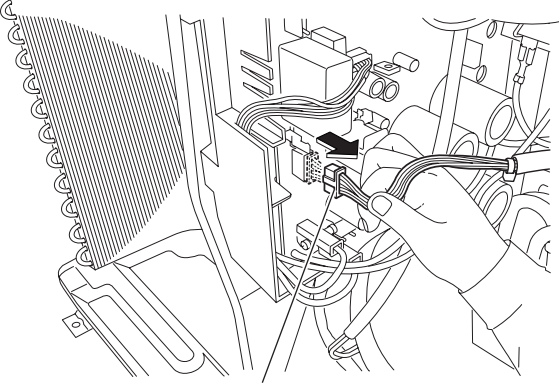
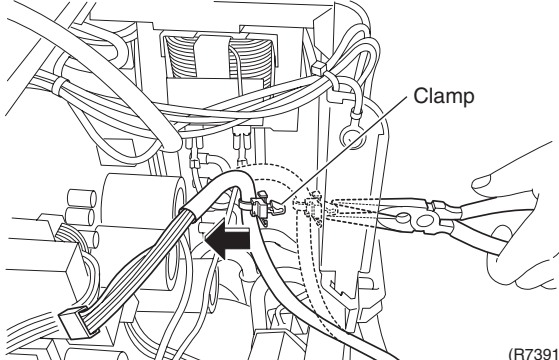
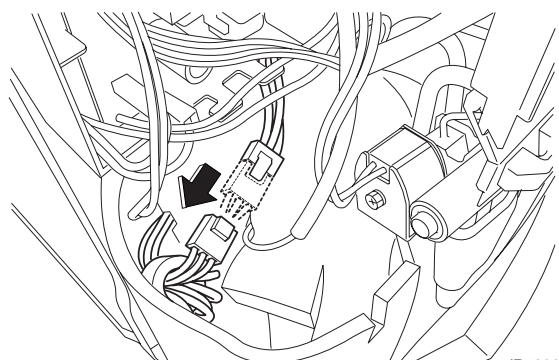
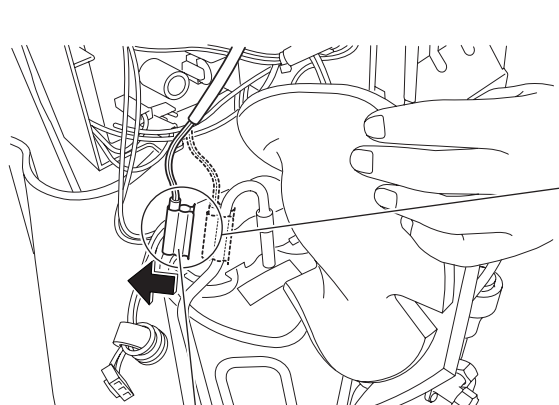
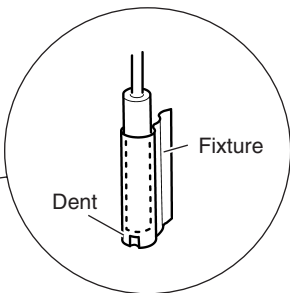
| Step | Procedure | Points |
|------|--|---|
| 3 | <p>Disconnect the connector for the electronic expansion valve coil [S20].</p>  <p style="text-align: center;">[S20] (R7390)</p> | |
| 4 | <p>Detach the clamp of the lead wire for the electronic expansion valve coil.</p>  <p style="text-align: center;">Clamp (R7391)</p> | |
| 5 | <p>Disconnect the relay connector for the compressor.</p>  <p style="text-align: center;">(R7392)</p> | <ul style="list-style-type: none"> ■ Pay attention so as not to lose the fixture for the thermistor. ■ When reassembling, do not insert the thermistor up to the dent of fixture. |
| 6 | <p>Release the discharge pipe thermistor.</p>  <p style="text-align: center;">Discharge pipe thermistor (R7393)</p> |  |

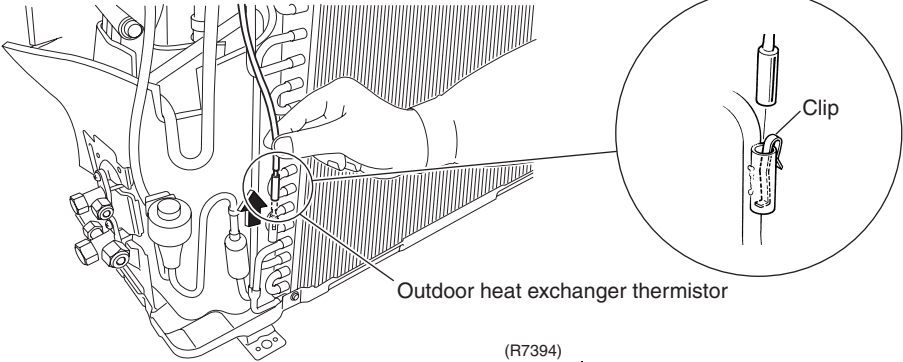
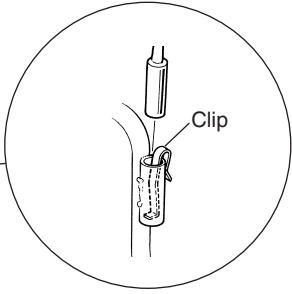
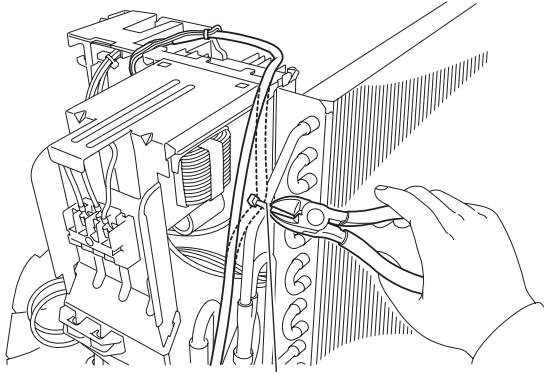
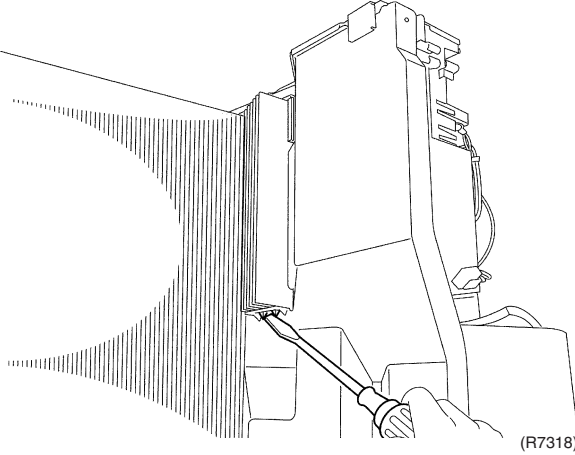
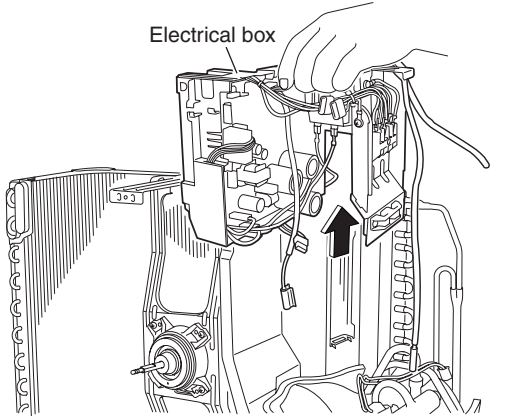
| Step | Procedure | Points |
|------|---|--|
| 7 | <p>Pull out the outdoor heat exchanger thermistor.</p>  <p>Outdoor heat exchanger thermistor</p> <p>(R7394)</p> |  <p>Clip</p> |
| 8 | <p>Cut the clamp.</p>  <p>Clamp</p> <p>(R7395)</p> | <ul style="list-style-type: none"> ■ Pay attention so as not to lose the clip for the thermistor. |
| 9 | <p>Unfasten the hook from the partition plate with a flat screwdriver.</p>  <p>(R7318)</p> | <ul style="list-style-type: none"> ■ The electrical box can be removed by lifting itself without a screwdriver. |
| 10 | <p>Lift and remove the electrical box.</p>  <p>Electrical box</p> <p>(R11236)</p> | |

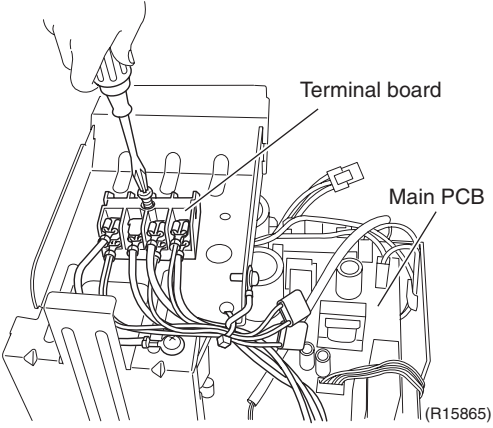
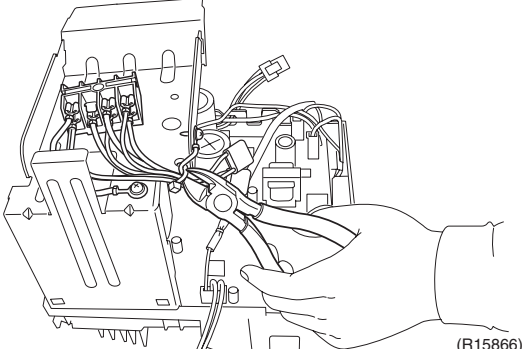
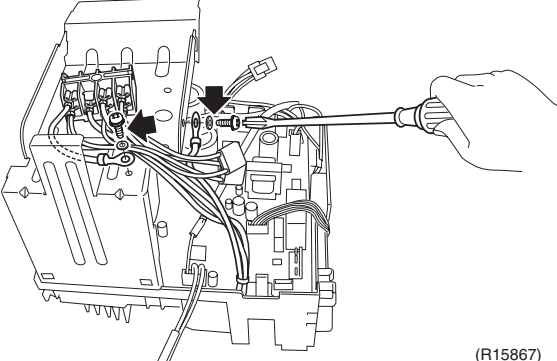
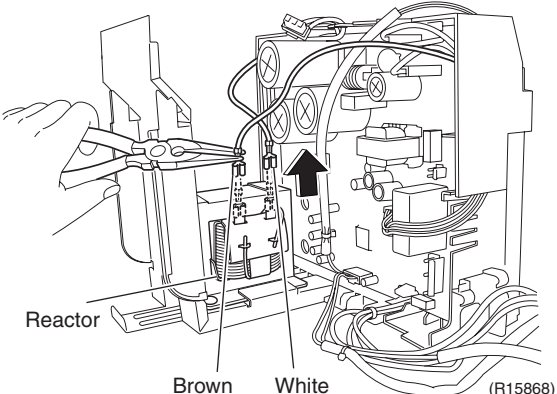
| Step | Procedure | Points |
|--------------------------------|---|--------|
| 3. Remove the main PCB. | | |
| 1 | Remove the screw on the terminal board.  | |
| 2 | Cut the clamp.  | |
| 3 | Remove the 2 screws of the earth wire.  | |
| 4 | Disconnect the 2 terminals of the reactor.  | |

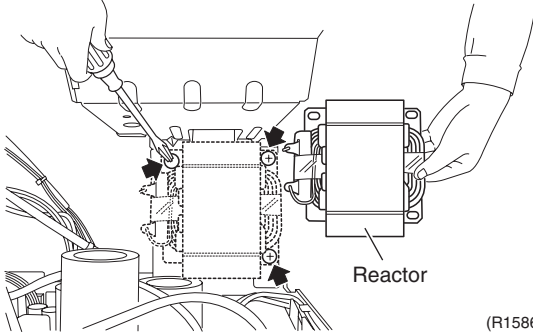
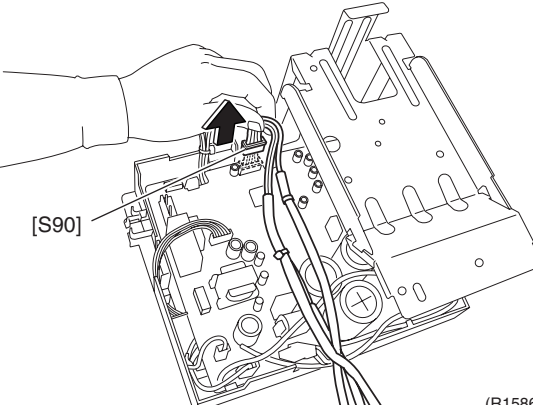
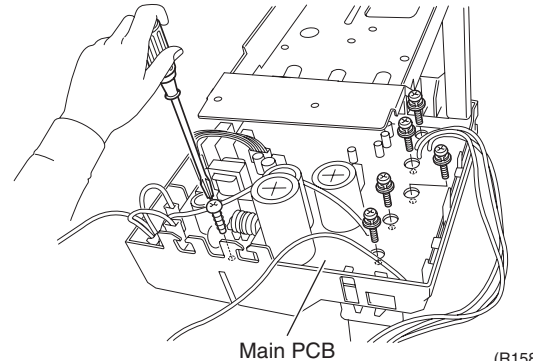
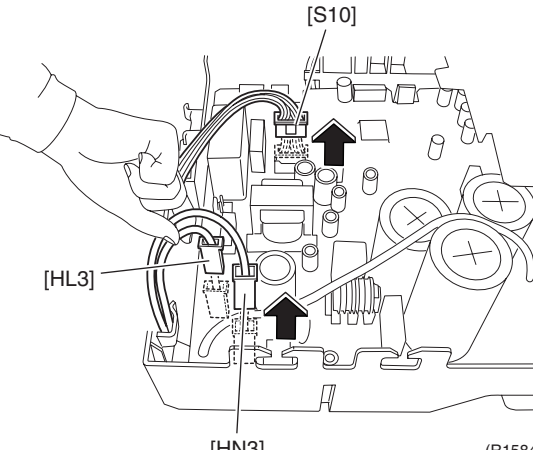
| Step | Procedure | Points |
|------|--|--------|
| 5 | <p>Remove the 3 screws to remove the reactor.</p>  <p style="text-align: right;">(R15862)</p> | |
| 6 | <p>Disconnect the connector for the thermistors [S90].</p>  <p style="text-align: right;">(R15863)</p> | |
| 7 | <p>Remove the 6 screws.</p>  <p style="text-align: center;">Main PCB</p> <p style="text-align: right;">(R15864)</p> | |
| 8 | <p>Disconnect the 3 connectors for the filter PCB [S10] [HL3] [HN3].</p>  <p style="text-align: right;">(R15849)</p> | |

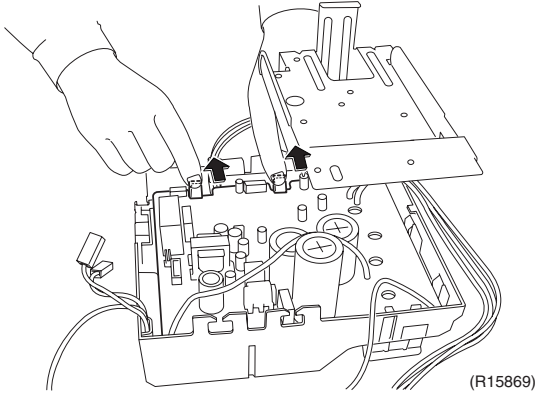
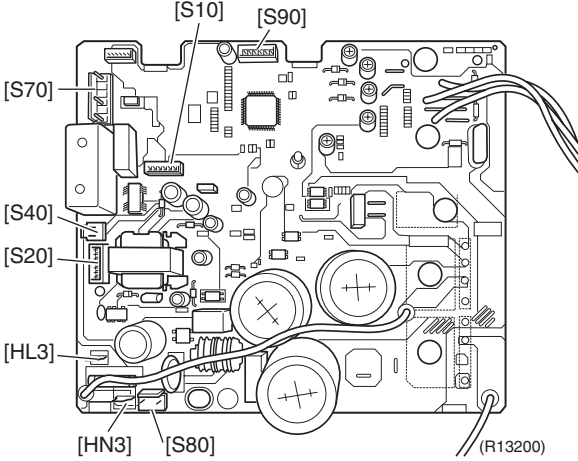
| Step | Procedure | Points |
|---|---|---|
| <p>9 Unfasten the 2 hooks. 10 Lift and remove the main PCB.</p> |  | |
| <p>11 Feature of the main PCB</p> |  | <p>[S10] [HL3] [HN3]: filter PCB [S20]: electronic expansion valve coil [S40]: overload protector [S70]: fan motor [S80]: four way valve coil [S90]: thermistors</p> |

4. Removal of Sound Blankets

Procedure



Warning Be sure to wait for 10 minutes or more after turning off all power supplies before disassembling work.

| Step | Procedure | Points |
|--------------------------------|-----------------|---|
| 1. Remove the partition plate. | <p>(R15870)</p> | |
| 1 Remove the 2 screws. | <p>(R11793)</p> | <p>■ When reassembling, fit the lower hook into the bottom frame.</p> |

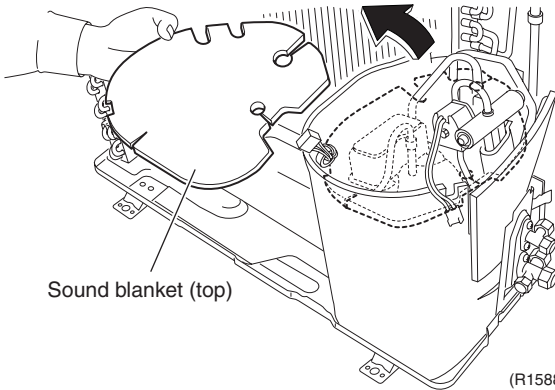
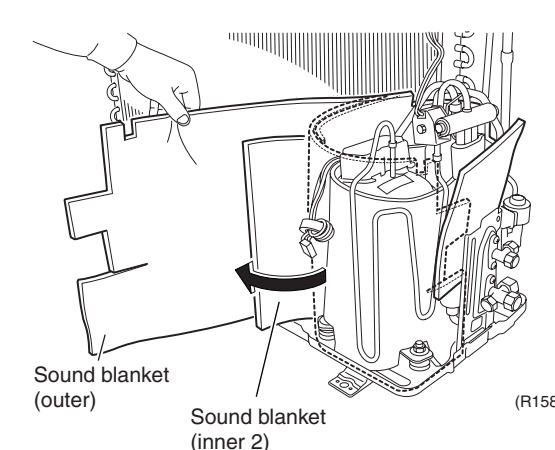
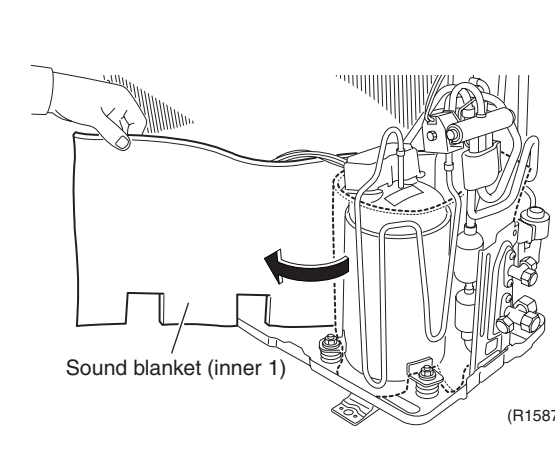
| Step | Procedure | Points |
|---|---|--|
| 2. Remove the sound blankets. |  <p>Sound blanket (top)</p> <p>(R15882)</p> | <ul style="list-style-type: none"> Since the piping ports on the sound blanket are torn easily, remove the blanket carefully. |
| 1 Lift and remove the sound blanket (top). |  <p>Sound blanket (outer)</p> <p>Sound blanket (inner 2)</p> <p>(R15883)</p> | |
| 2 Pull the sound blankets (outer, inner 2) out. |  <p>Sound blanket (inner 1)</p> <p>(R15871)</p> | |
| 3 Pull the sound blanket (inner 1) out. | | |

5. Removal of Four Way Valve

Procedure

Warning Be sure to wait for 10 minutes or more after turning off all power supplies before disassembling work.

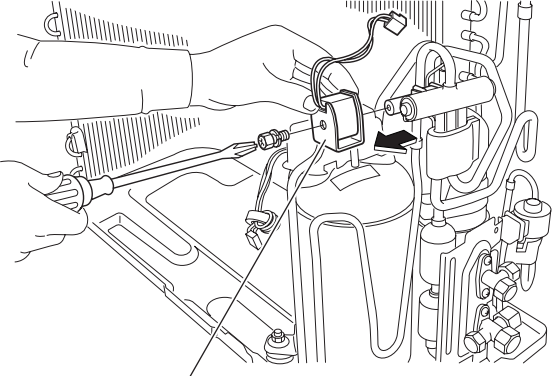
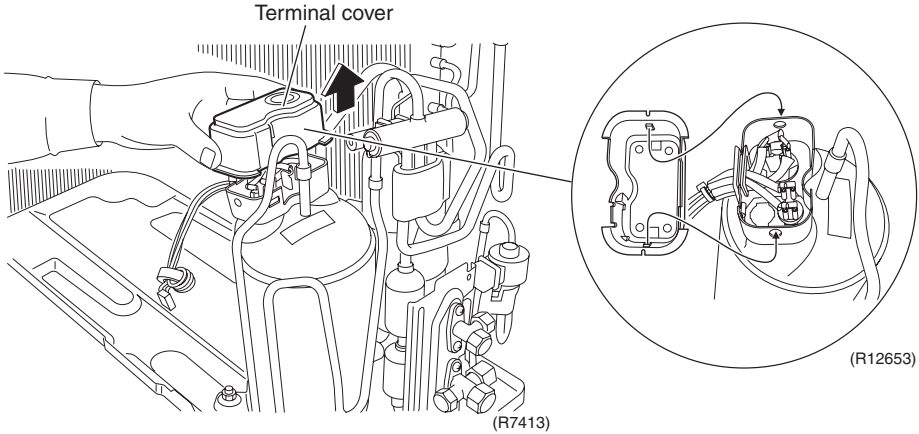
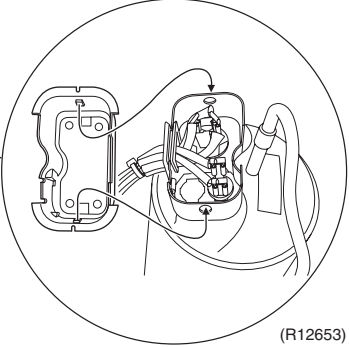
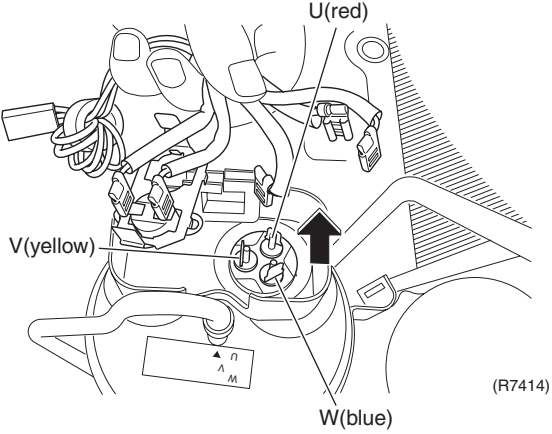
| Step | Procedure | Points |
|------|---|--|
| 1. | Remove the peripherals. | |
| 1 | Remove the screw and remove the four way valve coil.  <p>Four way valve coil (R7412)</p> | <ul style="list-style-type: none"> There are 2 hooks at the inner side of the terminal cover. |
| 2 | Remove the terminal cover.  <p>Terminal cover (R7413)</p> |  <p>(R12653)</p> |
| 3 | Disconnect the lead wires of the compressor.  <p>U(red) V(yellow) W(blue) (R7414)</p> | |

| Step | Procedure | Points |
|------|---|--------|
| 4 | Remove the electronic expansion valve coil. | |
| 5 | Remove the putty. | |

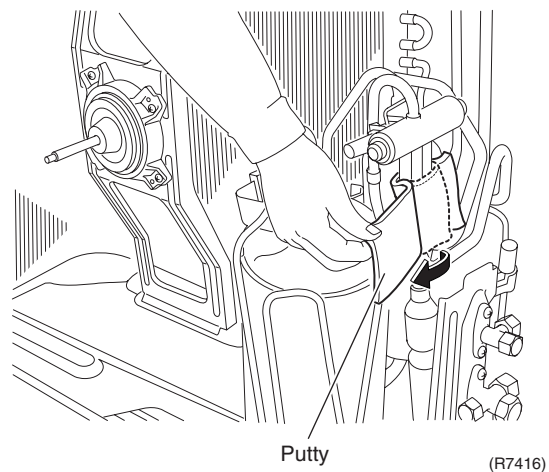
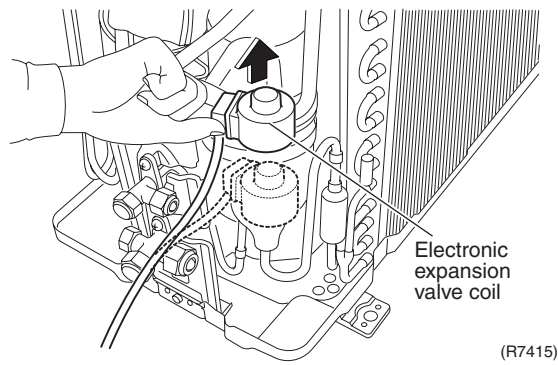

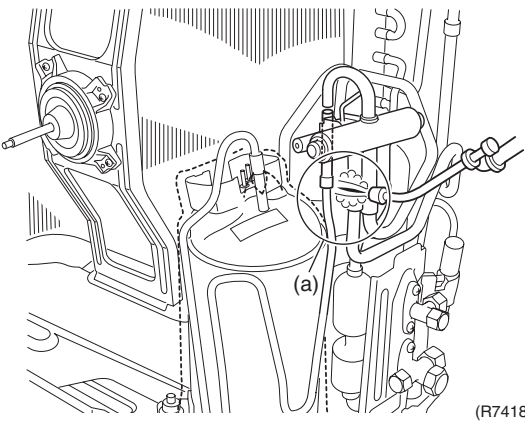
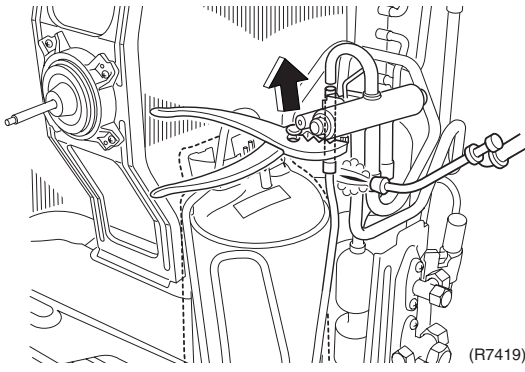
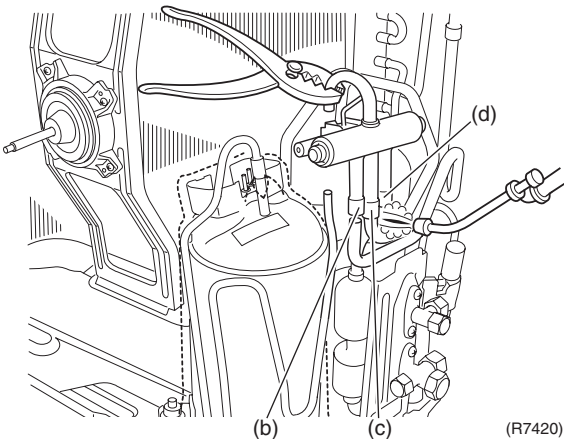
| Step | Procedure | Points |
|--|--|--|
| <ul style="list-style-type: none"> ■ Before working, make sure that the refrigerant gas is empty in the circuit. ■ Be sure to apply nitrogen replacement when heating up the brazed part. |  <p style="text-align: right;">(R7418)</p> | <p>Warning Be careful not to get yourself burnt with the pipes and other parts that are heated by the gas brazing machine.</p> |
| <p>2. Remove the four way valve.</p> | | <p>Warning If the refrigerant gas leaks during work, ventilate the room. (If the refrigerant gas is exposed to flames, toxic gas may be generated.)</p> |
| <p>1 Heat up the brazed part (a) and withdraw the piping with pliers.</p> <p>2 Heat up the 3 brazed parts of the four way valve. Disconnect the point (b) first.</p> <p>3 Disconnect the points (c) and (d).</p> |  <p style="text-align: right;">(R7419)</p>  <p style="text-align: right;">(R7420)</p> | <p>Caution From the viewpoint of global environment protection, do not discharge the refrigerant gas in the atmosphere. Make sure to collect all the refrigerant gas.</p> <p>Cautions for restoration</p> <ol style="list-style-type: none"> 1. Restore the piping by non-oxidation brazing. 2. It is required to prevent the carbonization of the oil inside the four way valve and the deterioration of the gaskets affected by heat. (Keep below 120°C.) For the sake of this, wrap the four way valve with wet cloth and provide water so that the cloth does not dry. |
| <p>Note:</p> <ul style="list-style-type: none"> ■ Do not use a metal saw for cutting pipes by all means because the sawdust comes into the circuit. ■ When withdrawing the pipes, be careful not to pinch them firmly with pliers. The pipes may get deformed. ■ Provide a protective sheet or a steel plate so that the brazing flame cannot influence peripheries. | | <p>In case of difficulty with gas brazing machine</p> <ol style="list-style-type: none"> 1. Disconnect the brazed part where is easy to disconnect and restore. 2. Cut pipes on the main unit with a tube cutter in order to make it easy to disconnect. |

6. Removal of Compressor

Procedure

Warning Be sure to wait for 10 minutes or more after turning off all power supplies before disassembling work.

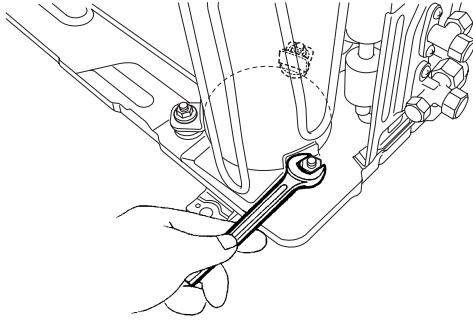
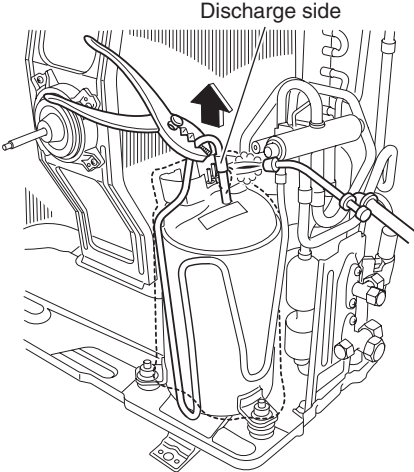
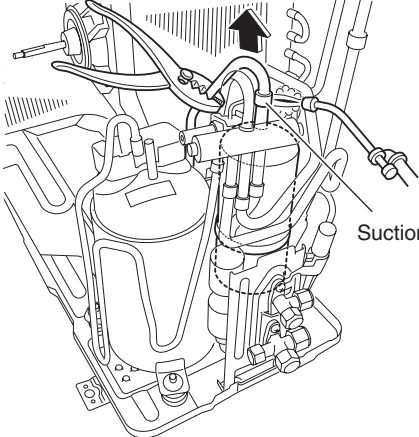
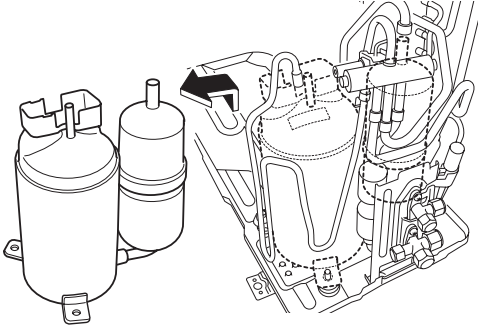
| Step | Procedure | Points |
|--|--|---|
| <p>1. Remove the peripheries.</p> <p>1 Remove the four way valve, the terminal cover and the lead wire for the compressor so as not to burn them.</p> <p>2 Remove the 3 nuts of the compressor.</p> |  <p style="text-align: right;">(R12022)</p> | <p>Warning Be careful not to get yourself burnt with the pipes and other parts that are heated by the gas brazing machine.</p> <p>Warning If the refrigerant gas leaks during work, ventilate the room. (If the refrigerant gas is exposed to flames, toxic gas may be generated.)</p> |
| <ul style="list-style-type: none"> ■ Before working, make sure that the refrigerant gas is empty in the circuit. ■ Be sure to apply nitrogen replacement when heating up the brazed part. |  <p style="text-align: right;">(R7422)</p> | <p>Warning Since it may happen that the refrigerant oil in the compressor catches fire, prepare wet cloth so as to extinguish fire immediately.</p> |
| <p>2. Remove the compressor.</p> <p>1 Heat up the brazed part of the discharge side and disconnect.</p> <p>2 Heat up the brazed part of the suction side and disconnect.</p> <p>3 Lift the compressor up and remove it.</p> |  <p style="text-align: right;">(R7423)</p> | <p>Caution From the viewpoint of global environment protection, do not discharge the refrigerant gas in the atmosphere. Make sure to collect all the refrigerant gas.</p> |
| <p>Note:</p> <ul style="list-style-type: none"> ■ Do not use a metal saw for cutting pipes by all means because the sawdust comes into the circuit. ■ When withdrawing the pipes, be careful not to pinch them firmly with pliers. The pipes may get deformed. ■ Provide a protective sheet or a steel plate so that the brazing flame cannot influence peripheries. ■ Be careful so as not to burn the compressor terminals, the name plate, the heat exchanger fin. |  <p style="text-align: right;">(R7424)</p> | <p>Cautions for restoration</p> <ol style="list-style-type: none"> 1. Restore the piping by non-oxidation brazing. 2. It is required to prevent the carbonization of the oil inside the four way valve and the deterioration of the gaskets affected by heat. (Keep below 120°C.) For the sake of this, wrap the four way valve with wet cloth and provide water so that the cloth does not dry. <p>In case of difficulty with gas brazing machine</p> <ol style="list-style-type: none"> 1. Disconnect the brazed part where is easy to disconnect and restore. 2. Cut pipes on the main unit with a tube cutter in order to make it easy to disconnect. |

Revision History

| Month / Year | Version | Revised contents |
|--------------|----------|------------------|
| 08/2012 | Si001158 | First edition |

Warning



- Daikin products are manufactured for export to numerous countries throughout the world. Prior to purchase, please confirm with your local authorised importer, distributor and/or retailer whether this product conforms to the applicable standards, and is suitable for use, in the region where the product will be used. This statement does not purport to exclude, restrict or modify the application of any local legislation.
- Ask a qualified installer or contractor to install this product. Do not try to install the product yourself. Improper installation can result in water or refrigerant leakage, electrical shock, fire or explosion.
- Use only those parts and accessories supplied or specified by Daikin. Ask a qualified installer or contractor to install those parts and accessories. Use of unauthorised parts and accessories or improper installation of parts and accessories can result in water or refrigerant leakage, electrical shock, fire or explosion.
- Read the User's Manual carefully before using this product. The User's Manual provides important safety instructions and warnings. Be sure to follow these instructions and warnings.

If you have any enquiries, please contact your local importer, distributor and/or retailer.

Cautions on product corrosion

1. Air conditioners should not be installed in areas where corrosive gases, such as acid gas or alkaline gas, are produced.
2. If the outdoor unit is to be installed close to the sea shore, direct exposure to the sea breeze should be avoided. If you need to install the outdoor unit close to the sea shore, contact your local distributor.

Dealer

DAIKIN INDUSTRIES, LTD.

Head Office:
Umeda Center Bldg., 2-4-12, Nakazaki-Nishi,
Kita-ku, Osaka, 530-8323 Japan

Tokyo Office:
JR Shinagawa East Bldg., 2-18-1, Konan,
Minato-ku, Tokyo, 108-0075 Japan

http://www.daikin.com/global_ac/

©All rights reserved