



Si001155EA

REMOVAL PROCEDURE



S E R V I C E M A N U A L

2.0/2.5/3.5 kW Class 9000/12000 Btu/h Class

-  Outdoor Unit
-  Inverter
-  Pair Type



Service Manual Removal Procedure

Outdoor Unit

●Cooling Only

**RKS20LVMA
RKS25LVMA
RKS35LVMA**

●Heat Pump

**RXS09LVJU
RXS12LVJU**

**RXS20LVMA
RXS25LVMA
RXS35LVMA**

RXS25LAVMA

**RXS25LBVMA
RXS35LBVMA**

RXS25RV1A

Table of Contents

1. Outer Panels / Fan Motor	2
2. Electrical Box	10
3. PCBs	13
4. Reactor / Partition Plate	20
5. Sound Blankets	21
6. Four Way Valve.....	23
7. Compressor.....	26



Note:

- The illustrations may be slightly different depending on the model.
- The illustrations are for heat pump models as representative.

1. Outer Panels / Fan Motor



Warning

◆ Be sure to wait for 10 minutes or more after turning off all power supplies before disassembling work.

Step	Procedure	Points
<p>1. Appearance features</p>		<ul style="list-style-type: none"> ■ Be careful not to cut your finger on the fins of the outdoor heat exchanger.
<p>2. Remove the outer panels.</p> <p>1 Remove the screw of the stop valve cover.</p> <p>2 Pull downward and remove the stop valve cover.</p>		<ul style="list-style-type: none"> ■ The stop valve cover is united with the shield plate. ■ When reassembling, make sure the 5 hooks are securely fastened.

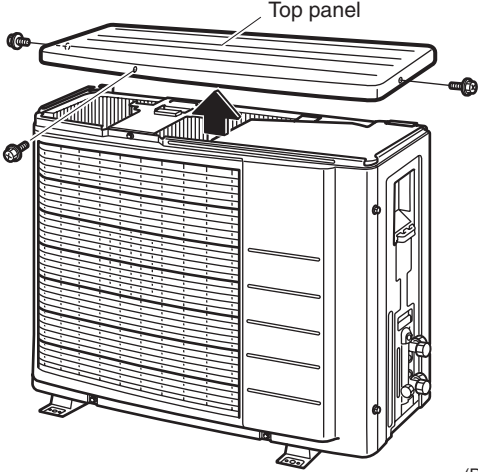
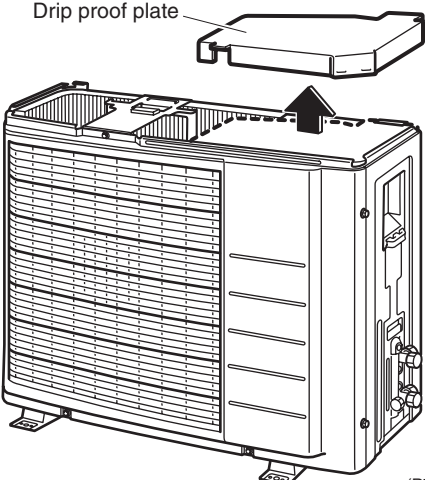
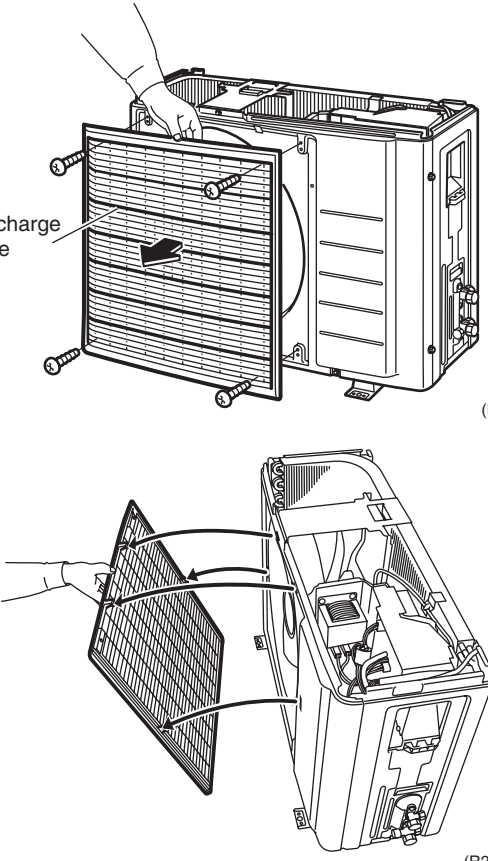
Step	Procedure	Points
3	Remove the 3 screws and lift the top panel.	 <p>Top panel</p> <p>(R13503)</p>
4	Remove the drip proof plate.	 <p>Drip proof plate</p> <p>(R7191)</p>
5	Remove the 4 screws, and then the discharge grille.	 <p>Discharge grille</p> <p>(R7192)</p> <p>(R24375)</p> <p>■ When reassembling, make sure the 4 hooks are securely fastened.</p>

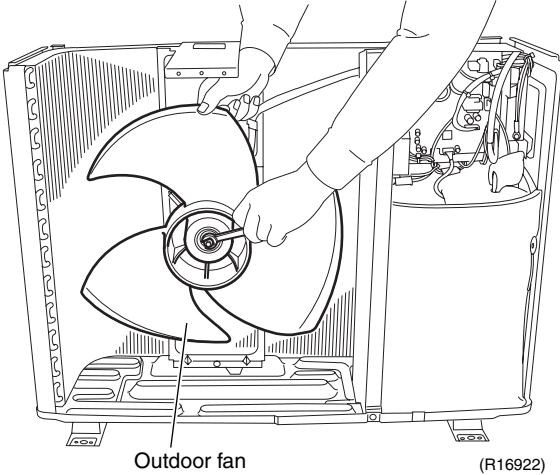
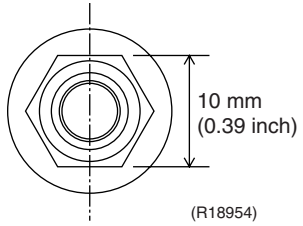
Step	Procedure	Points
6	Remove the 8 screws of the front panel.	
7	Unfasten the hooks and pull out the front panel.	<ul style="list-style-type: none"> ■ When reassembling, make sure the 4 hooks are securely fastened.
3. Remove the fan motor.	1 Remove the nut of the outdoor fan.	<ul style="list-style-type: none"> ■ Nut size: M6
	 <p>Outdoor fan (R16922)</p>	 <p>10 mm (0.39 inch) (R18954)</p>

Step	Procedure	Points
2	Remove the outdoor fan.	<ul style="list-style-type: none"> When reassembling, align the ▼ mark of the outdoor fan with the D-cut section of the motor shaft.
3	Release the outdoor temperature thermistor.	[S70]: fan motor
4	Disconnect the connector [S70].	
5	Release the fan motor lead wire from the hook.	

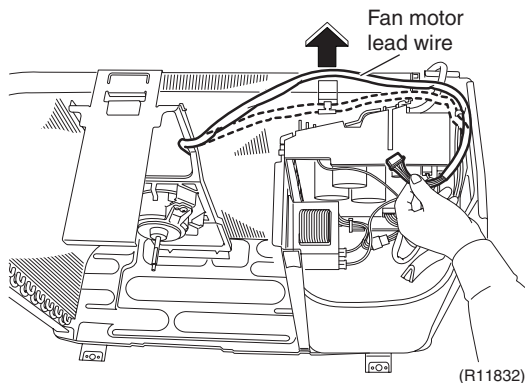
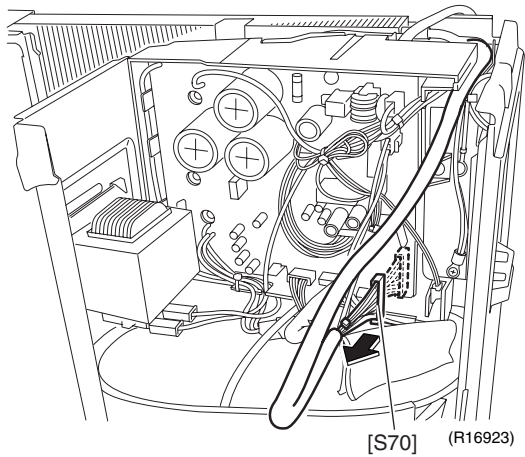
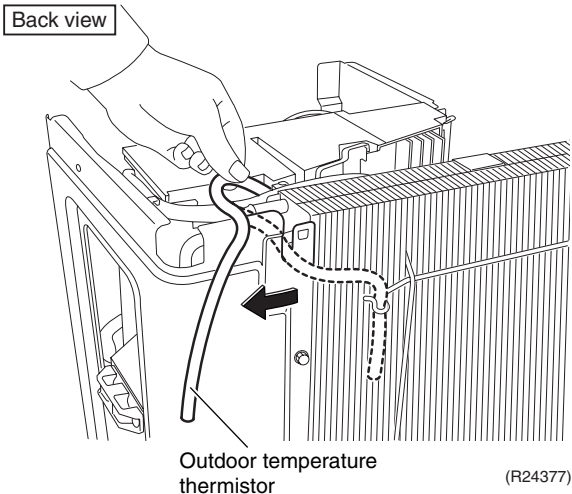
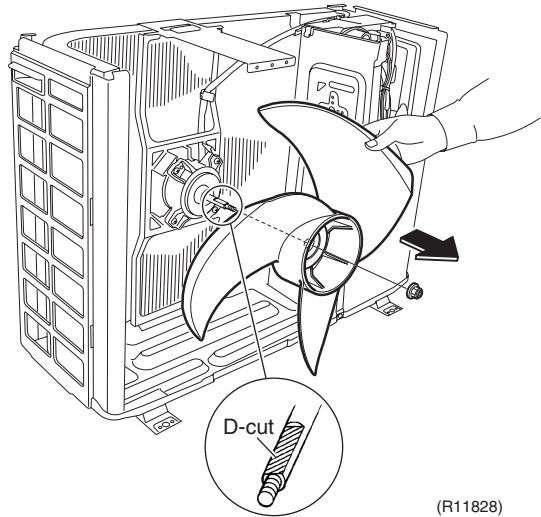

Step	Procedure	Points
6	Remove the screw.	
7	Remove the fan motor fixing frame.	

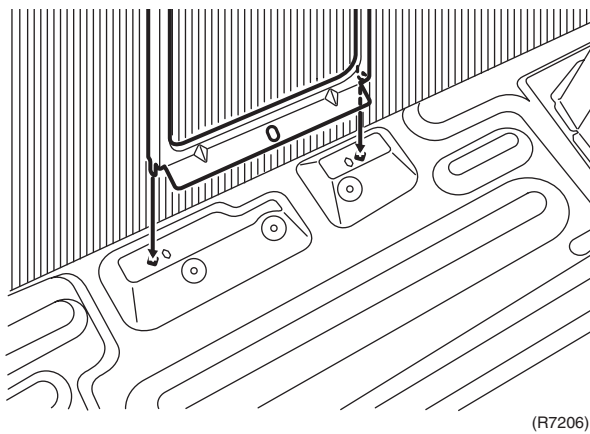
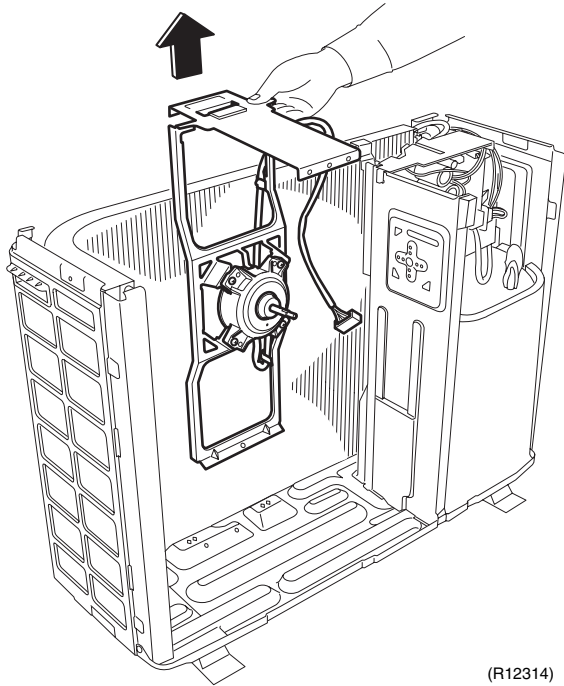
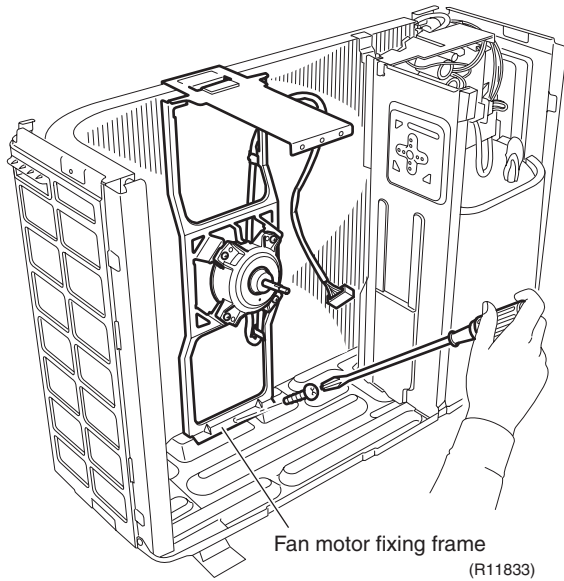

- When reassembling, fit the 2 lower hooks into the bottom frame.

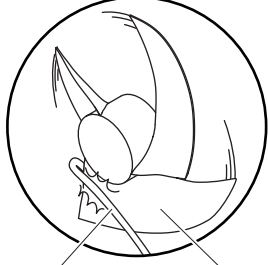
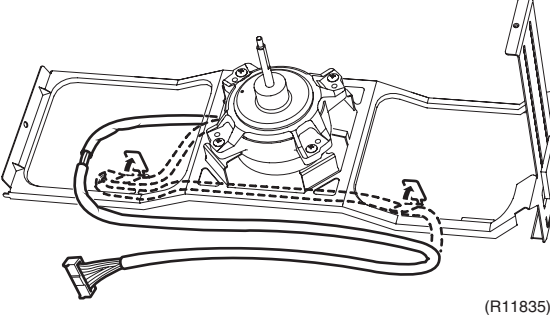
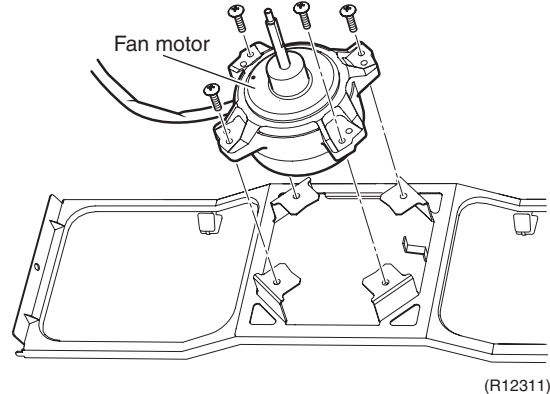
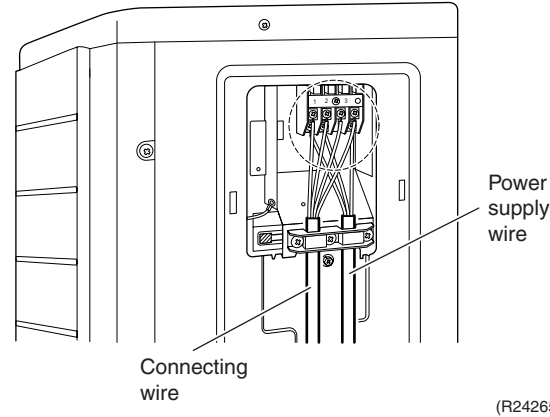
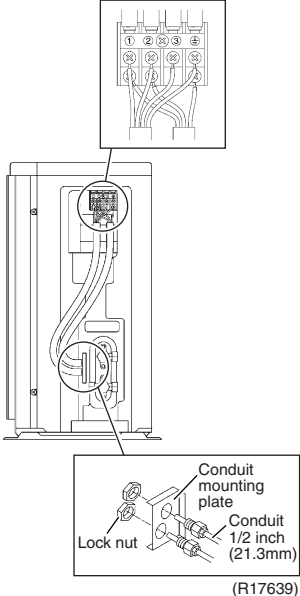
Step	Procedure	Points
8	Open the 2 hooks and release the fan motor lead wire.	<ul style="list-style-type: none"> When reassembling, put the fan motor lead wire through the back of the fan motor so as not to be entangled with the outdoor fan.
9	Remove the 4 screws, and then the fan motor.	 <p>Lead wire Outdoor fan (R3249)</p>
4. Remove the right side panel.	 <p>(R11835)</p>  <p>Fan motor (R12311)</p>	<p>For U.S. models</p> <ol style="list-style-type: none"> Remove the screws and detach the connecting wires from the terminal block. Loosen the lock nuts and detach the connecting wires from the conduit holes.
1 Remove the 3 screws, and then the wire fixture.	 <p>Connecting wire Power supply wire (R24265)</p>	 <p>Conduit mounting plate Conduit 1/2 inch (21.3mm) Lock nut (R17639)</p>

Step	Procedure	Points
3	Remove the 2 screws on the rear side.	
4	Remove the 4 screws on the right side panel.	
5	Remove the screw.	
6	Unfasten the hook on the rear side.	<p>■ When reassembling, make sure the hook is securely fastened.</p>

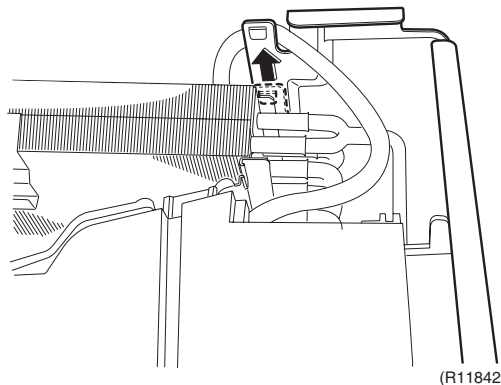
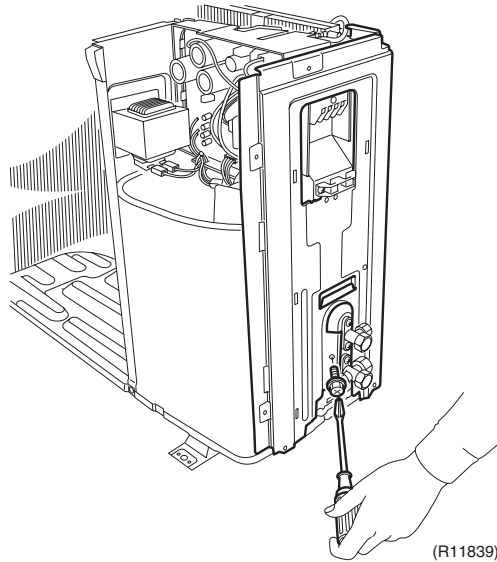
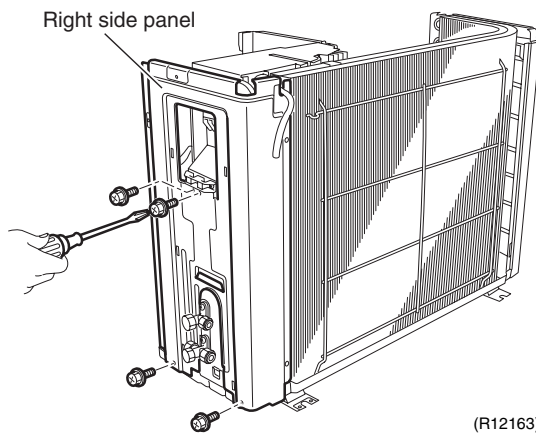
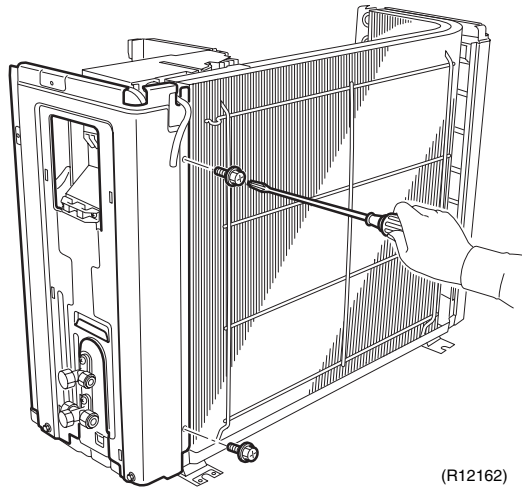

Step	Procedure	Points
7	Lift up the right side panel and remove it.	■ When reassembling, make sure the hook is securely fastened.
8	Lift up the guard net and remove it.	

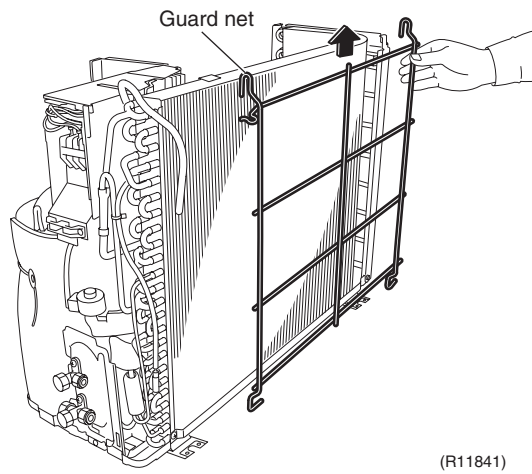
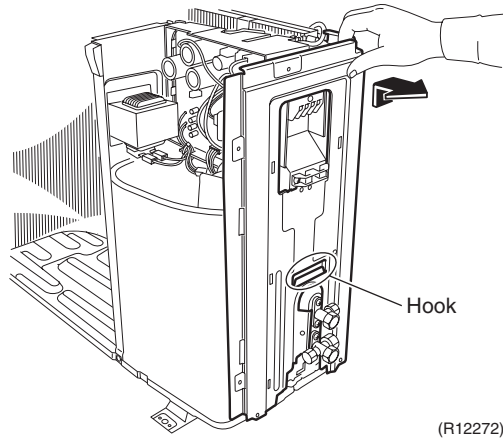

2. Electrical Box



Warning

- ◆ Be sure to wait for 10 minutes or more after turning off all power supplies before disassembling work.

Step	Procedure	Points
1	Disconnect the connector [S80].	<p>[S80]: four way valve coil</p> <ul style="list-style-type: none"> ■ The cooling only models do not have the harness for [S80].
2	Disconnect the connector [S20].	<p>[S20]: electronic expansion valve coil</p>
3	Disconnect the 2 connectors for the reactor.	<ul style="list-style-type: none"> ■ When reassembling, you can connect the 2 harnesses in either way regardless of the color.
4	Disconnect the relay connector for the compressor.	

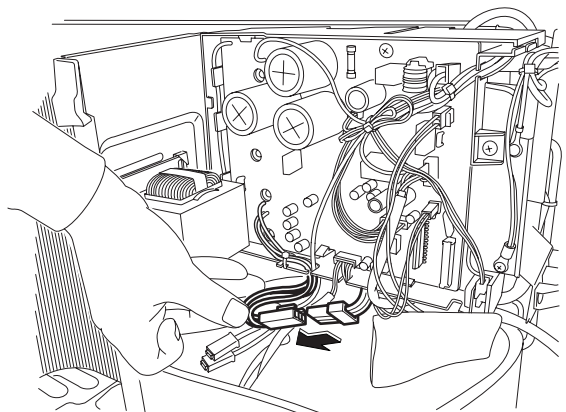
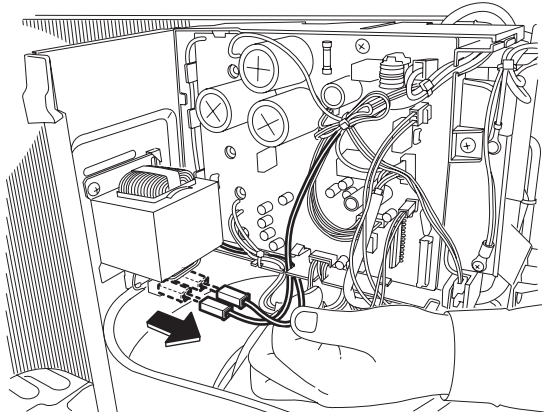
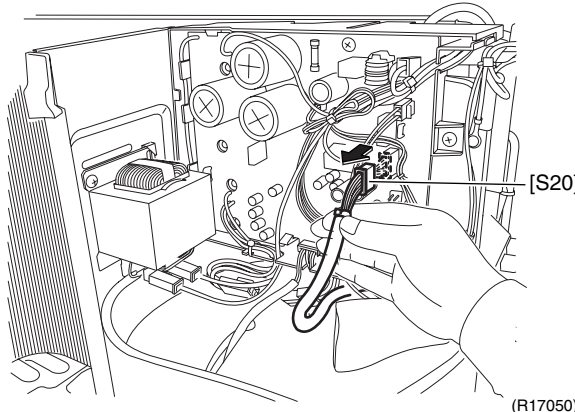
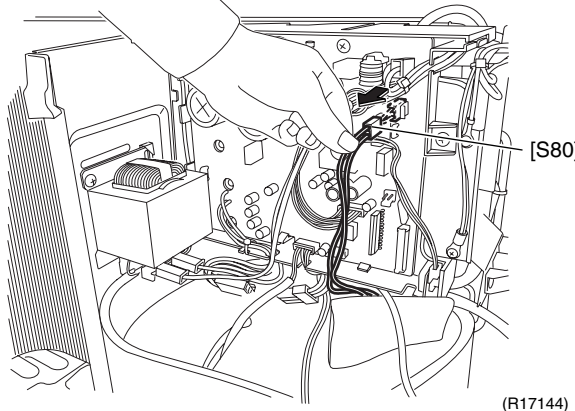

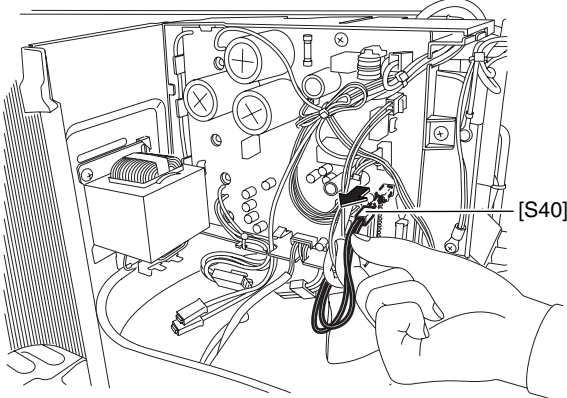
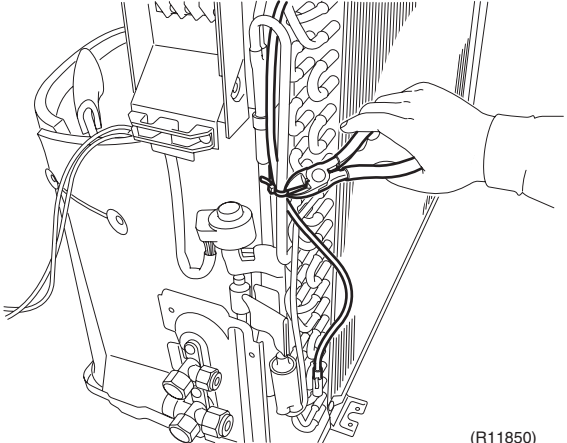
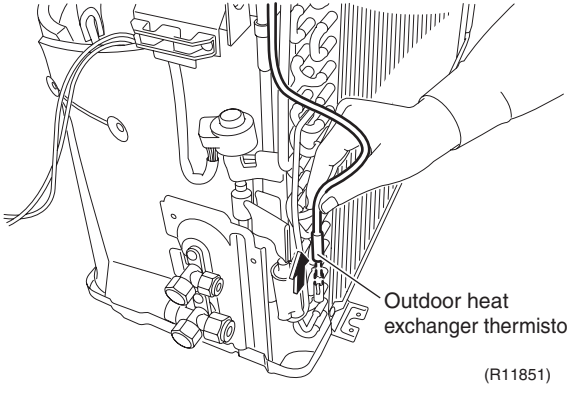
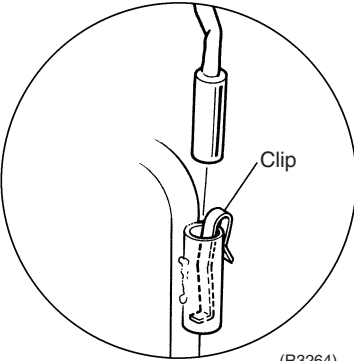
Step	Procedure	Procedure	Points
5	Disconnect the connector [S40].	 <p style="text-align: right;">(R16924)</p>	<p>[S40]: overload protector</p> <ul style="list-style-type: none"> ■ When reassembling, connect the connectors in the following order. <ol style="list-style-type: none"> (1) [S40] (2) relay connector for compressor (3) reactor (4) [S20] (5) [S70] (6) [S80]
6	Cut the clamp.	 <p style="text-align: right;">(R11850)</p>	
7	Pull out the outdoor heat exchanger thermistor.	 <p style="text-align: right;">(R11851)</p>	<ul style="list-style-type: none"> ■ Be careful not to lose the clip for the thermistor.  <p style="text-align: right;">(R3264)</p>

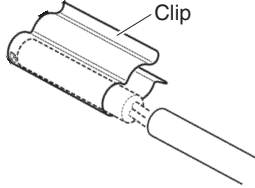
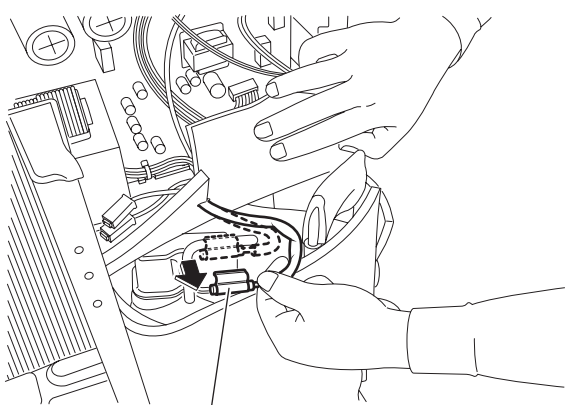
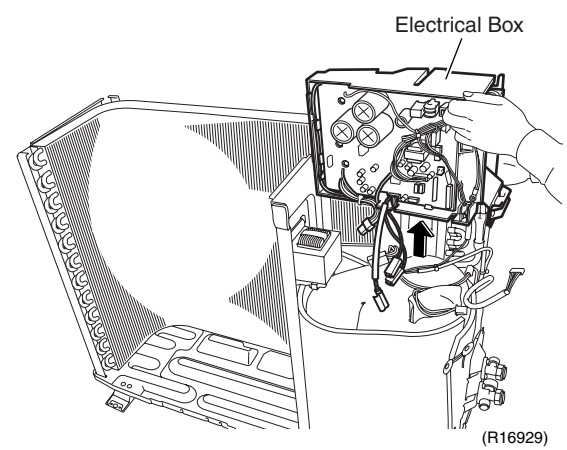
Step	Procedure	Points
8	Release the discharge pipe thermistor.	<ul style="list-style-type: none"> ■ Be careful not to lose the clip for the thermistor.
9	Lift and remove the electrical box.	 <p>Clip</p> <p>(R12279)</p>
	 <p>Discharge pipe thermistor (R11849)</p>	
	 <p>Electrical Box</p> <p>(R16929)</p>	

3. PCBs



Warning

- ◆ Be sure to wait for 10 minutes or more after turning off all power supplies before disassembling work.

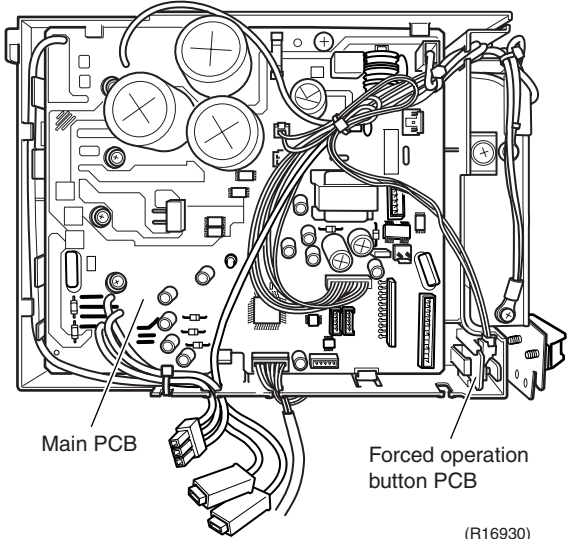
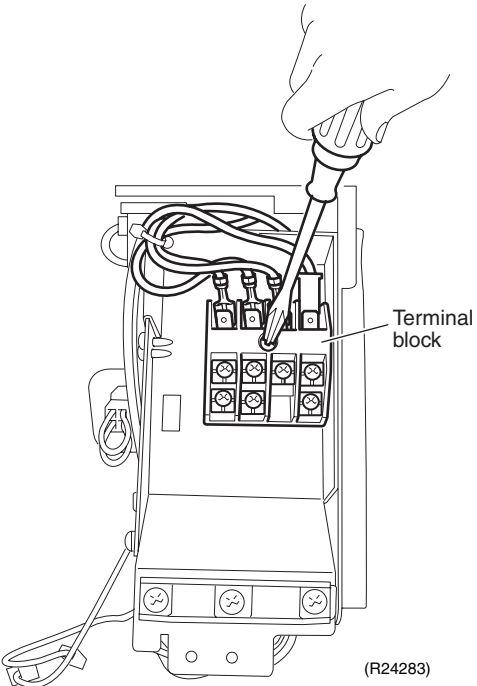
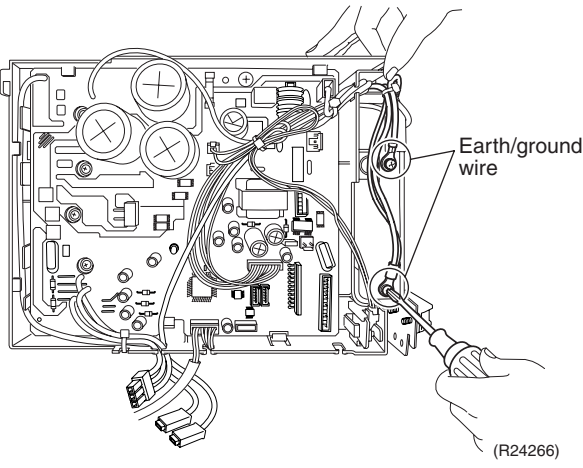
Step	Procedure	Points
1. Remove the main PCB and the forced operation button PCB.	 <p>Main PCB</p> <p>Forced operation button PCB</p> <p>(R16930)</p>	<ul style="list-style-type: none"> ■ You can remove the main PCB when you disconnect the lead wires on the terminal block without removing the electrical box.
1 Layout of the main PCB		
2 Remove the screw on the terminal block.	 <p>Terminal block</p> <p>(R24283)</p>	
3 Release the 2 earth/ground wires.	 <p>Earth/ground wire</p> <p>(R24266)</p>	

Step	Procedure	Points
4	Pull out the forced operation button PCB.	<ul style="list-style-type: none"> Be careful of the sharp protrusion at the back of the forced operation button PCB.
5	Disconnect the connector [S110].	[S110]: main PCB
6	Cut the clamp.	
7	Release the harness.	

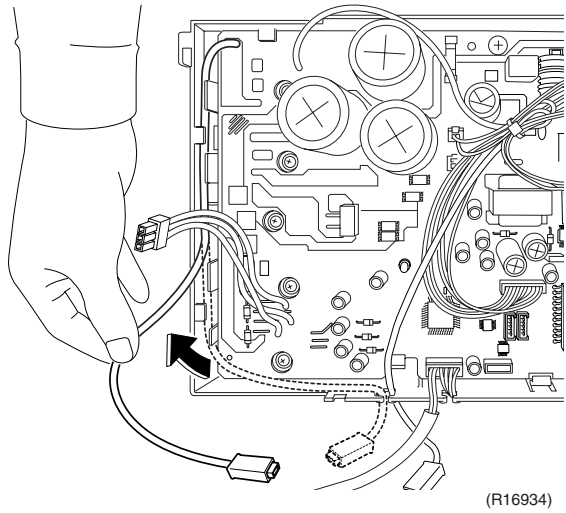
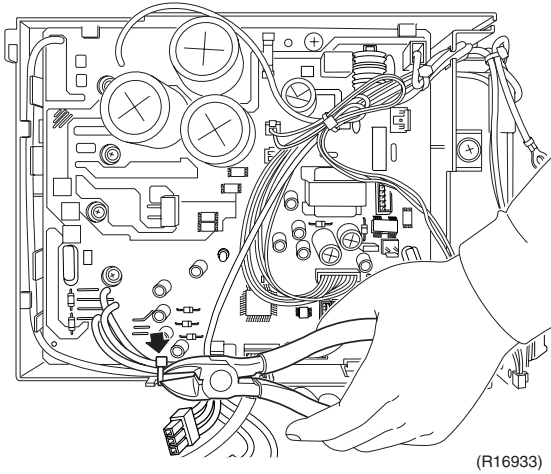
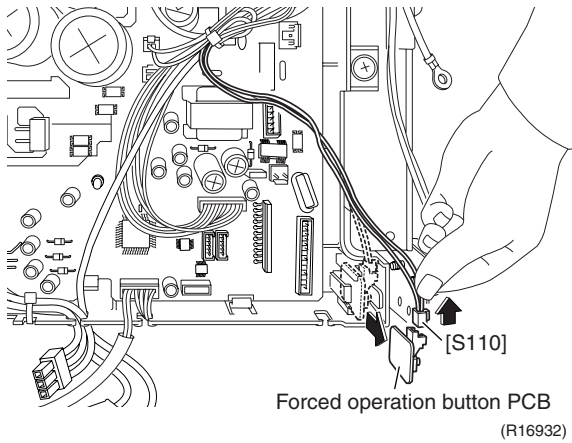

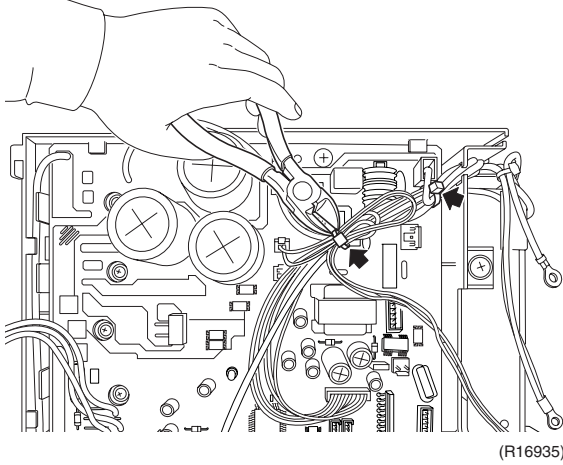
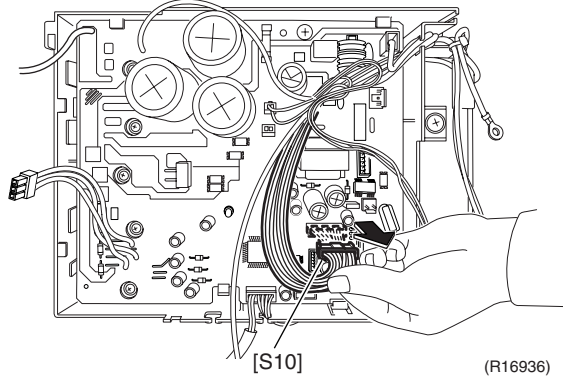
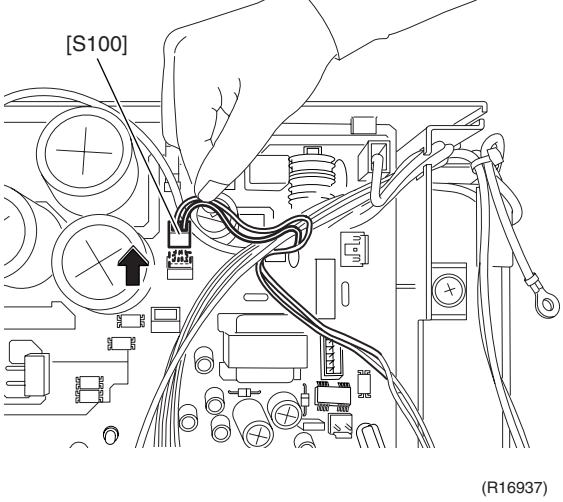
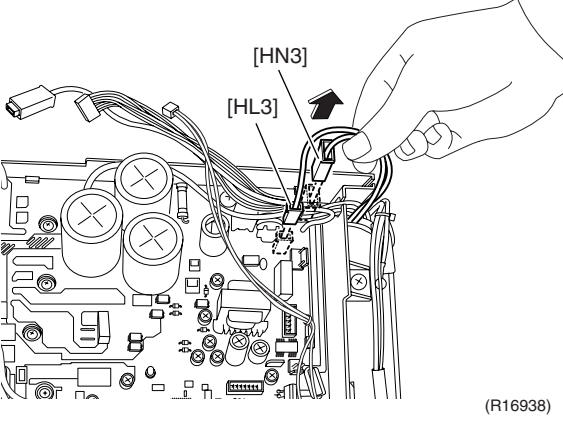
Step	Procedure	Points
8	Cut the 2 clamps.	
	 <p style="text-align: right;">(R16935)</p>	
9	Disconnect the connector [S10].	[S10]: filter PCB
	 <p style="text-align: right;">(R16936)</p>	
10	Disconnect the connector [S100].	[S100]: forced operation button PCB
	 <p style="text-align: right;">(R16937)</p>	
11	Disconnect the connectors [HL3] and [HN3].	[HL3][HN3]: filter PCB
	 <p style="text-align: right;">(R16938)</p>	

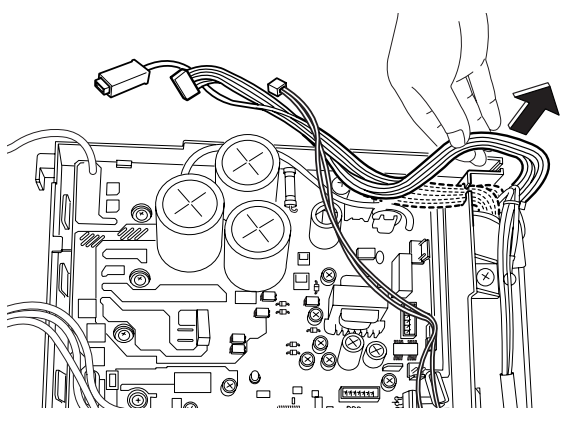
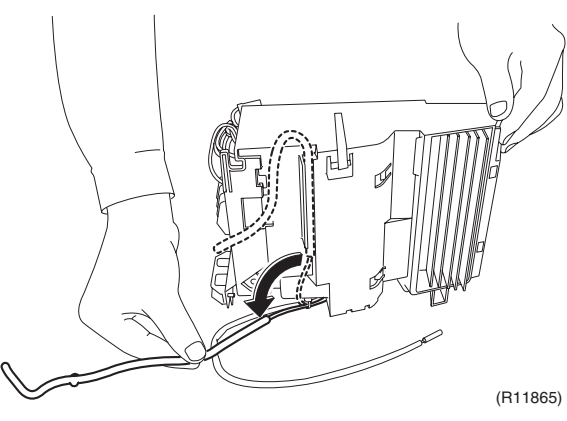
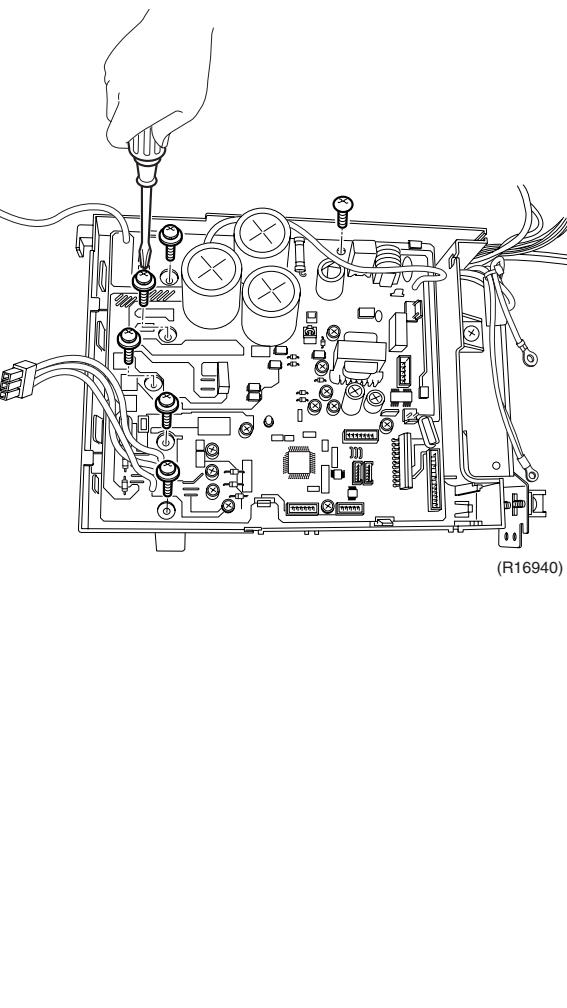
Step	Procedure	Points
<p>12 Release the harnesses from the slit.</p>	 <p>(R16939)</p>	
<p>13 Release the harness for the outdoor temperature thermistor.</p>	 <p>(R11865)</p>	
<p>14 Remove the 6 screws.</p>	 <p>(R16940)</p>	

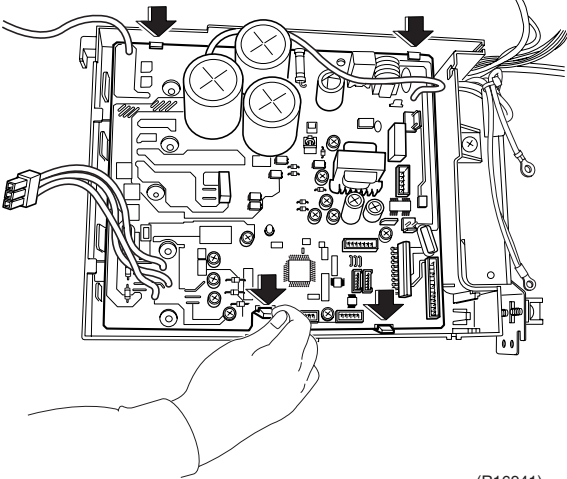
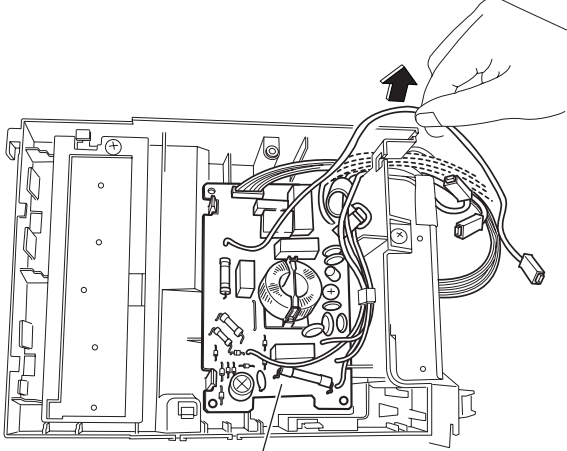
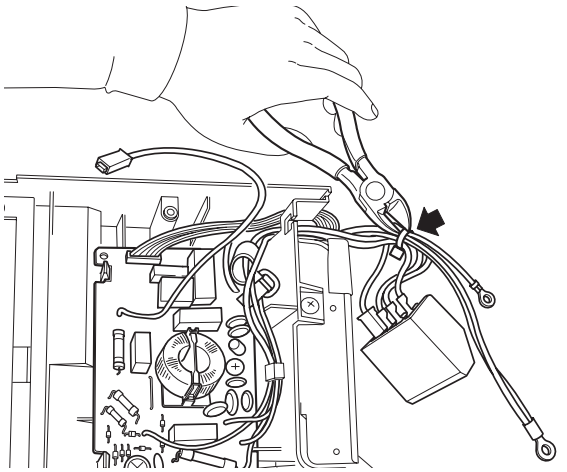
Step	Procedure	Points
15	Unfasten the 4 hooks and remove the main PCB.	 <p style="text-align: right;">(R16941)</p>
2.	Remove the filter PCB.	
1	Release the harnesses from the slit.	 <p style="text-align: center;">Filter PCB</p> <p style="text-align: right;">(R16942)</p>
2	Cut the clamp.	 <p style="text-align: right;">(R16943)</p>

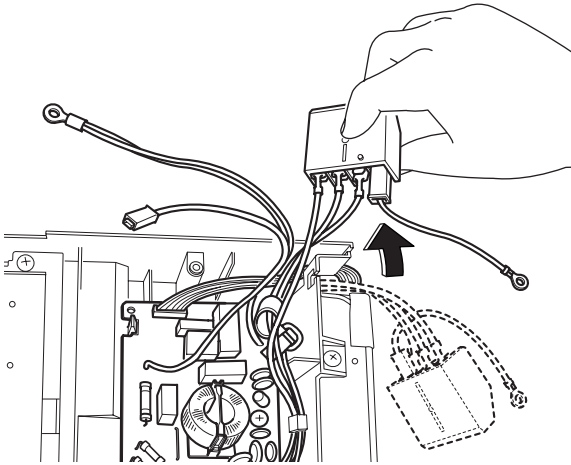
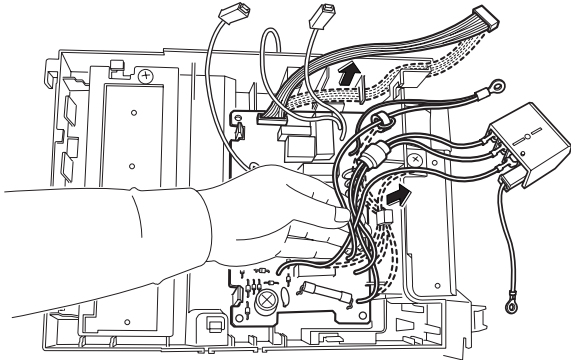
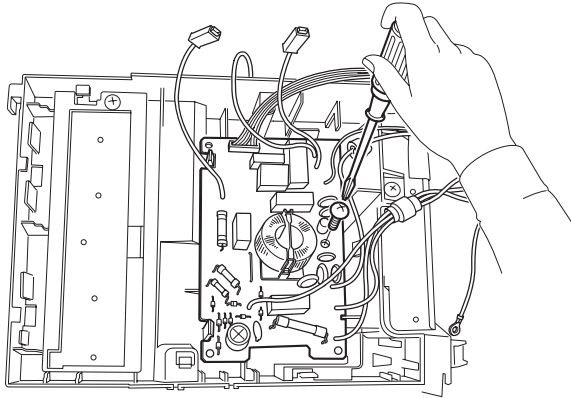
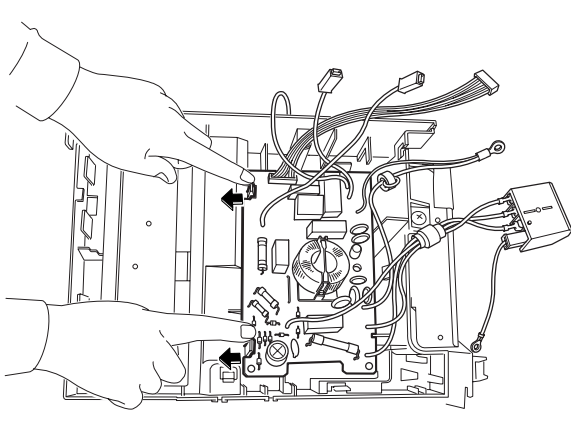
Step	Procedure	Points
3	Release the harnesses from the slit.	
	 <p>(R16944)</p>	
4	Release the harnesses from the 2 hooks.	
	 <p>(R16945)</p>	
5	Remove the screw.	
	 <p>(R17244)</p>	
6	Unfasten the 2 hooks.	
	 <p>(R24267)</p>	

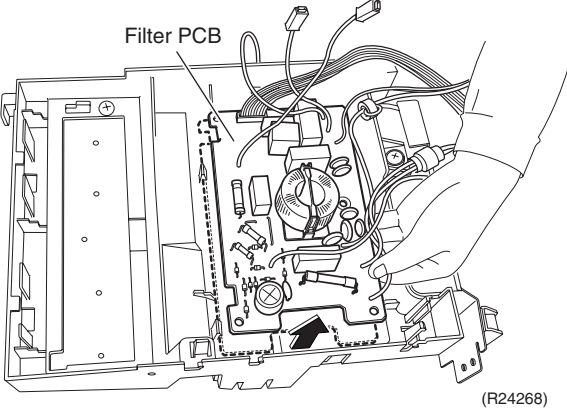
Step	Procedure	Points
7	Lift and pull out the filter PCB.	
	 <p>Filter PCB</p> <p>(R24268)</p>	

4. Reactor / Partition Plate



Warning

◆ Be sure to wait for 10 minutes or more after turning off all power supplies before disassembling work.

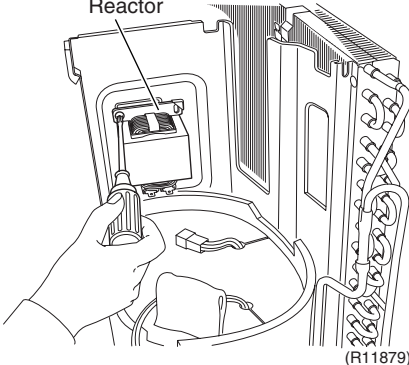
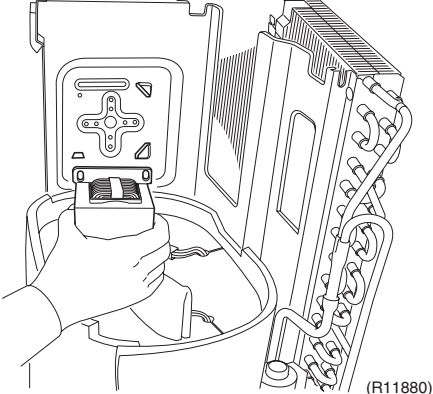
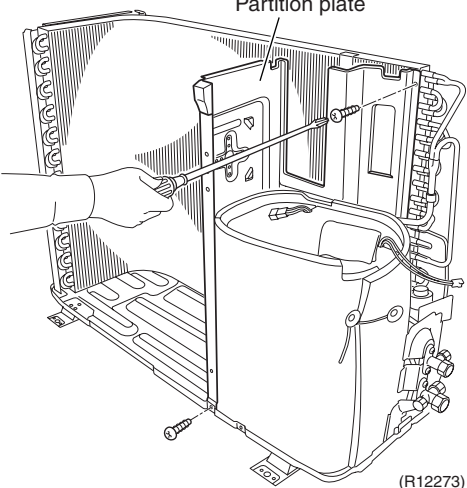
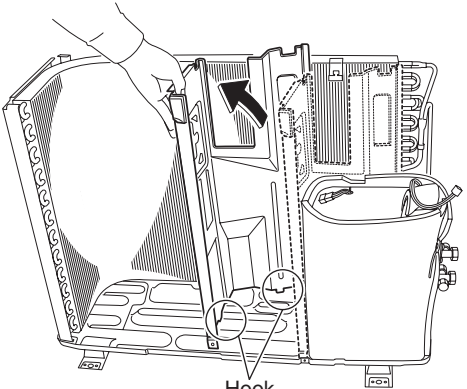
Step	Procedure	Points
<p>1. Remove the reactor.</p> <p>1 Remove the screw, and then the reactor.</p>	 <p>(R11879)</p>  <p>(R11880)</p>	
<p>2. Remove the partition plate.</p> <p>1 Remove the 2 screws.</p> <p>2 Lift and pull the partition plate to remove.</p>	 <p>(R12273)</p>  <p>(R13508)</p>	<p>■ When reassembling, fit the 2 lower hooks into the bottom frame.</p>

5. Sound Blankets



Warning

- ◆ Be sure to wait for 10 minutes or more after turning off all power supplies before disassembling work.

Step	Procedure	Points
1	Remove the sound blanket (top).	<ul style="list-style-type: none"> ■ Since the piping ports are torn easily, remove the sound blankets carefully.
2	Untie the string and open the sound blanket (outer).	
3	Lift and remove the sound blanket (outer).	

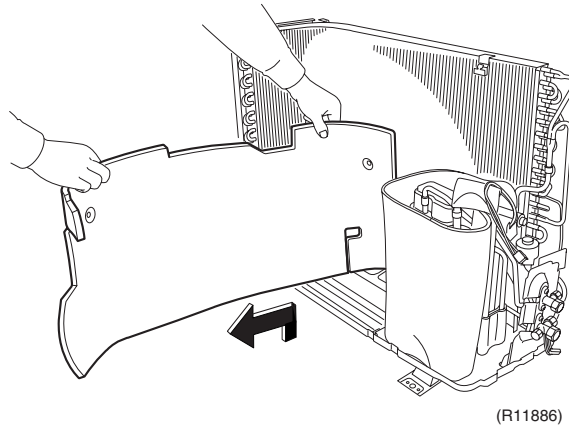
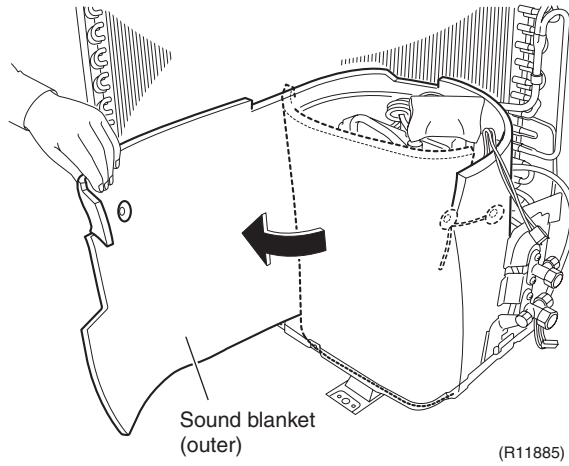
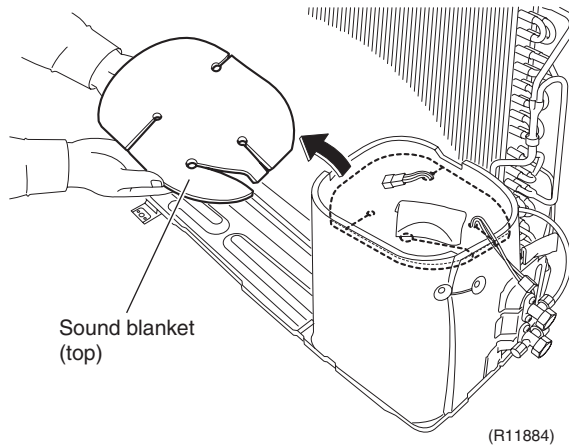

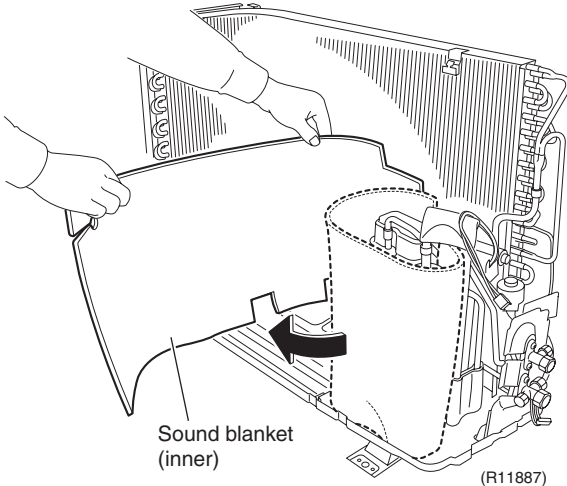
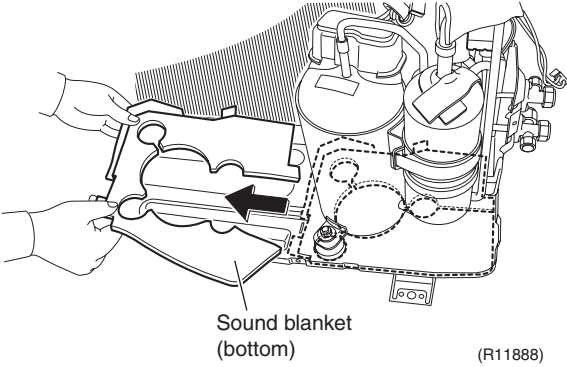
Step	Procedure	Points
4	Pull out the sound blanket (inner).	
		
5	Pull out the sound blanket (bottom).	
		

6. Four Way Valve



Warning

- ♦ Be sure to wait for 10 minutes or more after turning off all power supplies before disassembling work.
- ♦ Be careful not to get yourself burnt with the pipes and other parts that are heated by the gas brazing machine.
- ♦ If the refrigerant gas leaks during work, ventilate the room. (If the refrigerant gas is exposed to flames, toxic gas may be generated.)



Caution

- ♦ From the viewpoint of global environment protection, do not discharge the refrigerant gas in the atmosphere. Make sure to collect all the refrigerant gas.
- ♦ Cautions for restoration
 1. Restore the piping by non-oxidation brazing.
 2. It is required to prevent the carbonization of the oil inside the four way valve and the deterioration of the gaskets affected by heat. (Keep below 120°C (248°F).) For the sake of this, wrap the four way valve with wet cloth and provide water so that the cloth does not dry.



Note

- ♦ Before working, make sure that the refrigerant gas is empty in the circuit.
- ♦ Be sure to apply nitrogen replacement when heating up the brazed part.
- ♦ Do not use a metal saw for cutting pipes by all means because the sawdust comes into the circuit.
- ♦ When withdrawing the pipes, be careful not to pinch them firmly with pliers. The pipes may get deformed.
- ♦ Provide a protective sheet or a steel plate so that the brazing flame cannot influence peripheries.
- ♦ Be careful so as not to burn the compressor terminals, the name plate, the outdoor heat exchanger fin.
- ♦ In case of difficulty with gas brazing machine
 1. Disconnect the brazed part where is easy to disconnect and restore.
 2. Cut pipes on the main unit with a tube cutter in order to make it easy to disconnect.

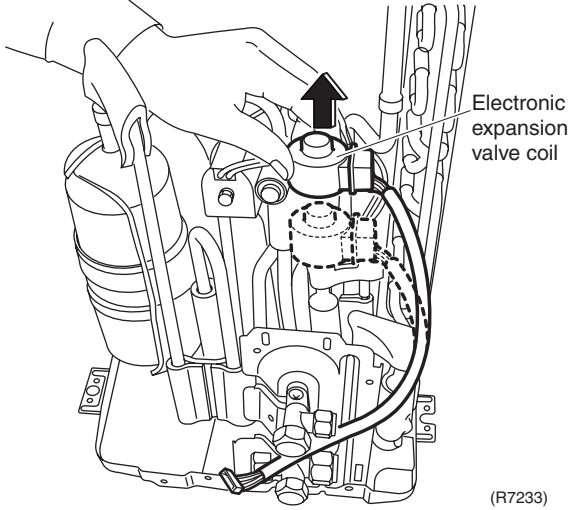
Step		Procedure	Points
1	Pull out the electronic expansion valve coil.		

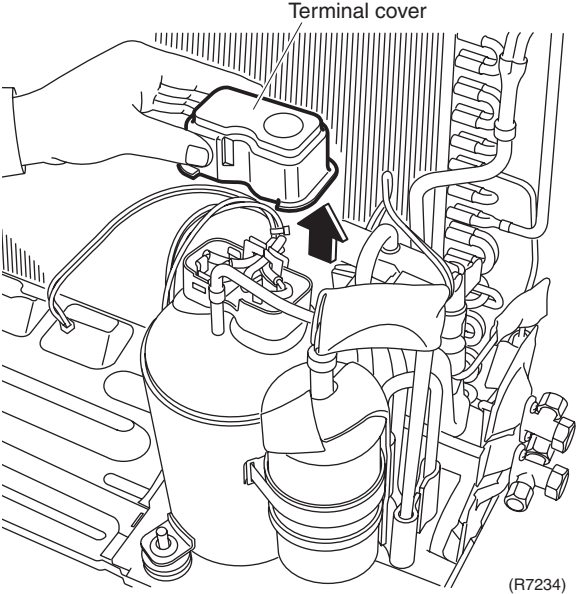
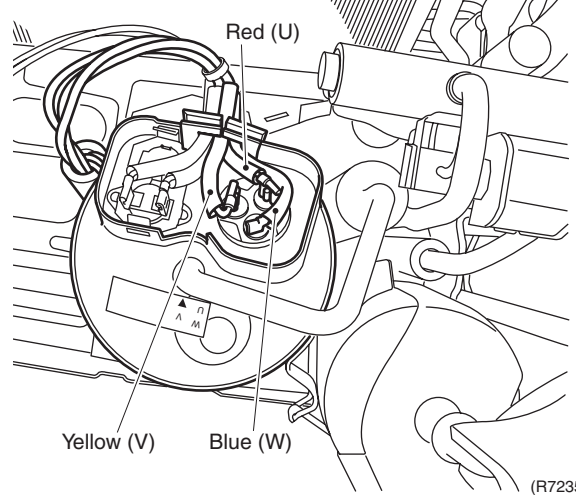
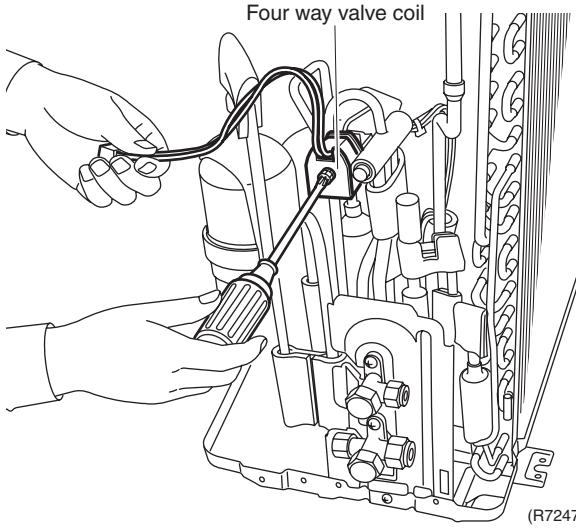
Step	Procedure	Points
2	Remove the terminal cover.	 <p>(R7234)</p>
3	Disconnect the lead wires (U, V, W) of the compressor.	 <p>(R7235)</p>
4	Remove the screw, and then the four way valve coil.	 <p>(R7247)</p> <p>■ The cooling only models do not have the four way valve coil.</p>

Step	Procedure	Points
5	Remove the putty.	
6	Heat up the brazed part and withdraw the piping with pliers.	

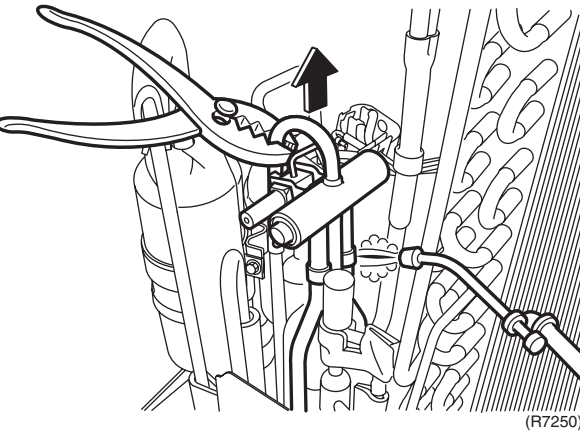
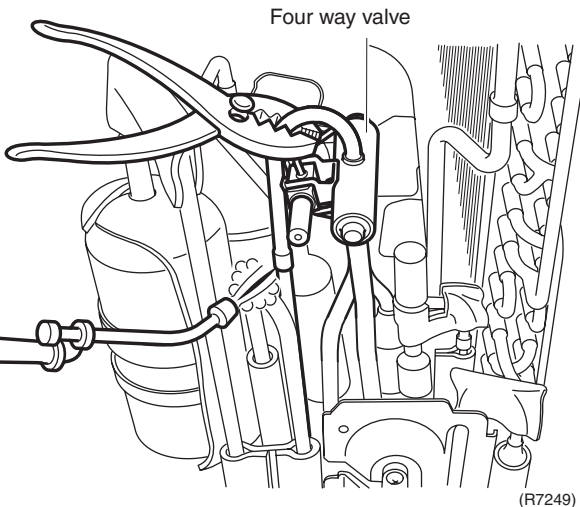
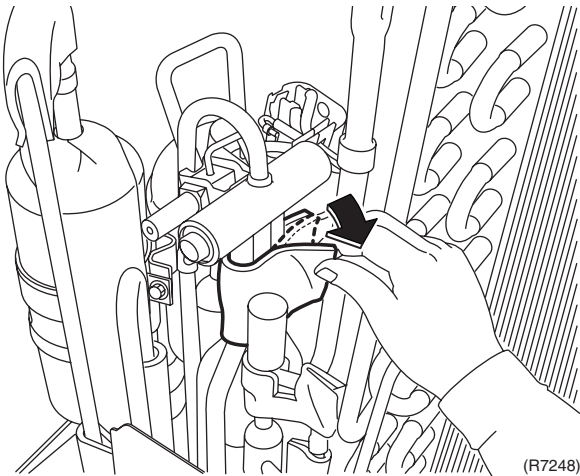

7. Compressor



Warning

- ◆ Be sure to wait for 10 minutes or more after turning off all power supplies before disassembling work.
- ◆ Be careful not to get yourself burnt with the pipes and other parts that are heated by the gas brazing machine.
- ◆ If the refrigerant gas leaks during work, ventilate the room. (If the refrigerant gas is exposed to flames, toxic gas may be generated.)
- ◆ Since it may happen that the refrigerant oil in the compressor catches fire, prepare wet cloth so as to extinguish fire immediately.



Caution

- ◆ From the viewpoint of global environment protection, do not discharge the refrigerant gas in the atmosphere. Make sure to collect all the refrigerant gas.
- ◆ Restore the piping by non-oxidation brazing.



Note

- ◆ Before working, make sure that the refrigerant gas is empty in the circuit.
- ◆ Be sure to apply nitrogen replacement when heating up the brazed part.
- ◆ Do not use a metal saw for cutting pipes by all means because the sawdust comes into the circuit.
- ◆ When withdrawing the pipes, be careful not to pinch them firmly with pliers. The pipes may get deformed.
- ◆ Provide a protective sheet or a steel plate so that the brazing flame cannot influence peripheries.
- ◆ Be careful so as not to burn the compressor terminals, the name plate, the outdoor heat exchanger fin.
- ◆ In case of difficulty with gas brazing machine
 1. Disconnect the brazed part where is easy to disconnect and restore.
 2. Cut pipes on the main unit with a tube cutter in order to make it easy to disconnect.

Step	Procedure	Points
1	Remove the 2 nuts of the compressor.	<div data-bbox="491 1218 1066 1778" data-label="Image"> </div> <div data-bbox="1086 1196 1455 2114"> <p>■ Some models have 3 nuts.</p> </div>

Step	Procedure	Points
2	Remove the putties.	
3	Heat up the brazed part of the discharge side pipe and disconnect it.	
4	Heat up the brazed part of the suction side pipe and disconnect it.	
5	Lift the compressor up and remove it.	

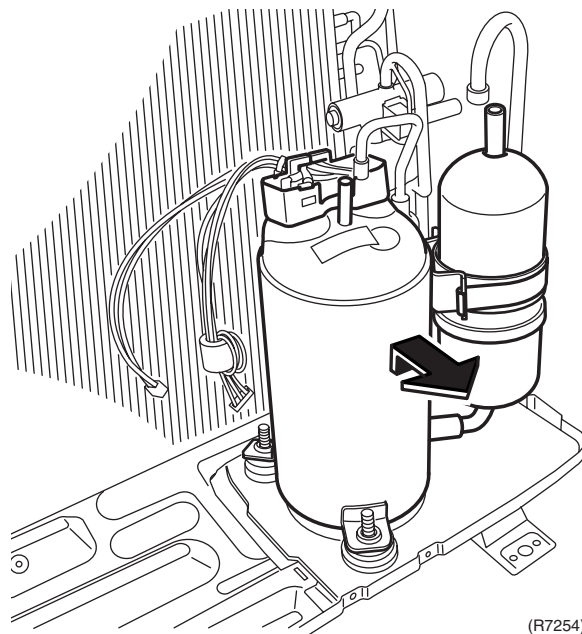
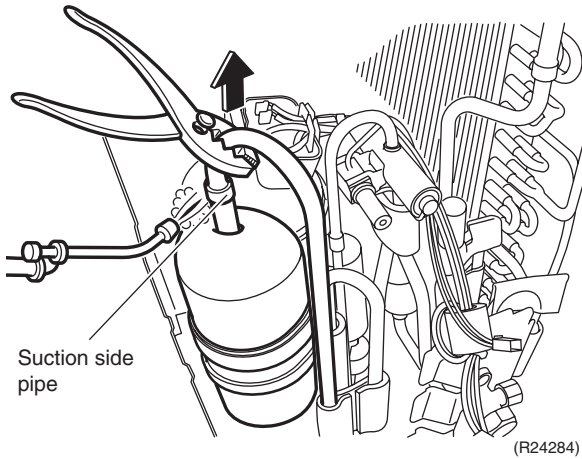
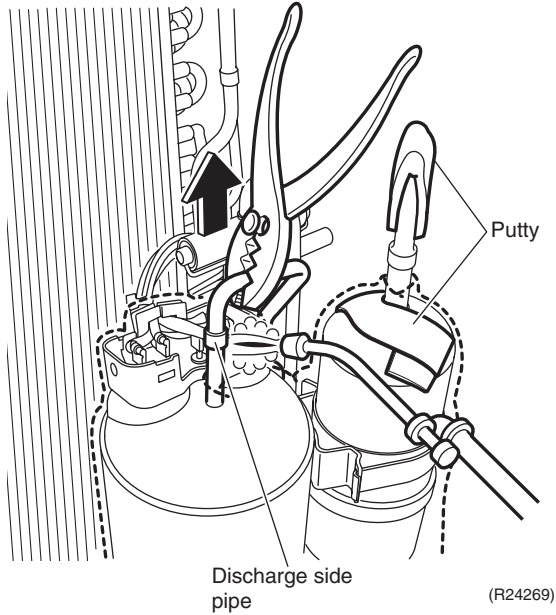

Revision History

Month / Year	Version	Revised contents
08 / 2012	Si001155	First edition
12 / 2016	Si001155EA	Model addition: RXS25RV1A

Warning



- Daikin products are manufactured for export to numerous countries throughout the world. Prior to purchase, please confirm with your local authorised importer, distributor and/or retailer whether this product conforms to the applicable standards, and is suitable for use, in the region where the product will be used. This statement does not purport to exclude, restrict or modify the application of any local legislation.
- Ask a qualified installer or contractor to install this product. Do not try to install the product yourself. Improper installation can result in water or refrigerant leakage, electrical shock, fire or explosion.
- Use only those parts and accessories supplied or specified by Daikin. Ask a qualified installer or contractor to install those parts and accessories. Use of unauthorised parts and accessories or improper installation of parts and accessories can result in water or refrigerant leakage, electrical shock, fire or explosion.
- Read the user's manual carefully before using this product. The user's manual provides important safety instructions and warnings. Be sure to follow these instructions and warnings.

If you have any enquiries, please contact your local importer, distributor and/or retailer.

Cautions on product corrosion

1. Air conditioners should not be installed in areas where corrosive gases, such as acid gas or alkaline gas, are produced.
2. If the outdoor unit is to be installed close to the sea shore, direct exposure to the sea breeze should be avoided. If you need to install the outdoor unit close to the sea shore, contact your local distributor.

Dealer

DAIKIN INDUSTRIES, LTD.

Head Office:
Umeda Center Bldg., 2-4-12, Nakazaki-Nishi,
Kita-ku, Osaka, 530-8323 Japan

Tokyo Office:
JR Shinagawa East Bldg., 2-18-1, Konan,
Minato-ku, Tokyo, 108-0075 Japan

<http://www.daikin.com/products/ac/>

©All rights reserved