

REMOVAL PROCEDURE



S E R V I C E M A N U A L

2.0 kW Class

-  Outdoor Unit
-  Inverter
-  Pair Type



Service Manual Removal Procedure

Outdoor Unit

●Heat Pump
RXL20G2V1B

Table of Contents

| | |
|---|----|
| 1. Removal of Outer Panels / Fan Motor..... | 2 |
| 2. Removal of Electrical Box | 10 |
| 3. Removal of Drain Pan Heater ASSY..... | 13 |
| 4. Removal of Thermistors | 15 |
| 5. Removal of PCB..... | 16 |
| 6. Removal of Reactor / Partition Plate | 18 |
| 7. Removal of Sound Blankets..... | 20 |
| 8. Removal of Four Way Valve | 21 |
| 9. Removal of Compressor | 24 |

1. Removal of Outer Panels / Fan Motor

Procedure

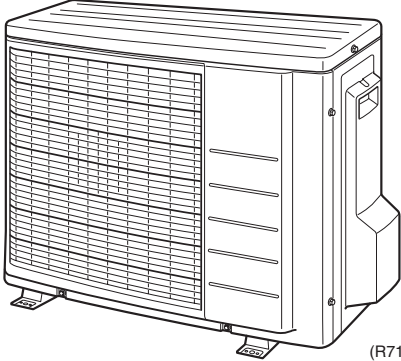
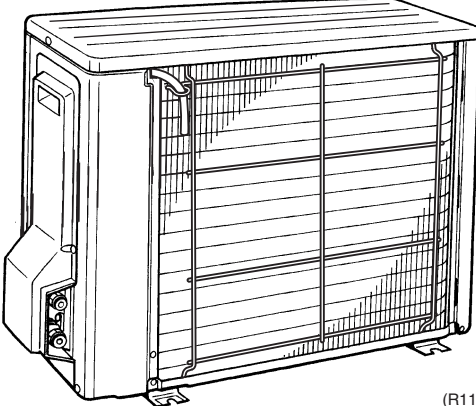
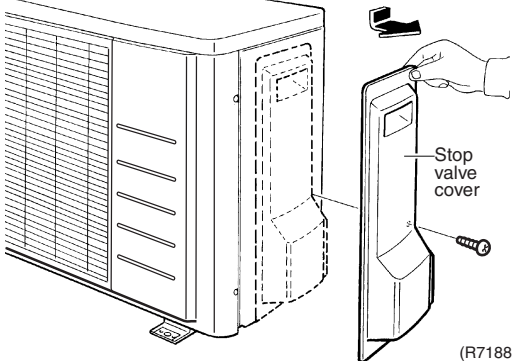
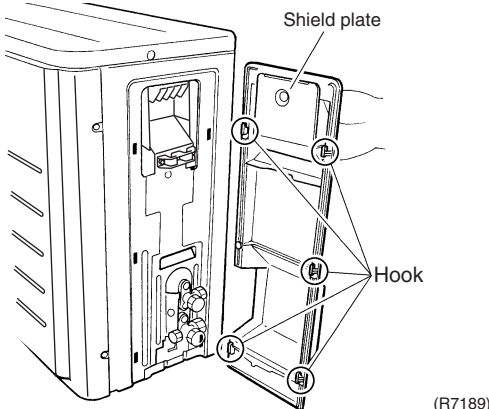

Warning Be sure to wait for 10 minutes or more after turning off all power supplies before disassembling work.

| Step | Procedure | Points |
|-----------------------|--|---|
| 1. Features |  <p>(R7186)</p>  <p>(R11890)</p> | <ul style="list-style-type: none"> ■ Take care not to cut your finger by the fins of the outdoor heat exchanger. |
| 2. Remove the panels. | <p>1 Remove the screw of the stop valve cover. Pull down the stop valve cover and remove it.</p>  <p>(R7188)</p>  <p>(R7189)</p> | <ul style="list-style-type: none"> ■ The stop valve cover is united with the shield plate. ■ When reassembling, make sure to fit the 5 hooks. |

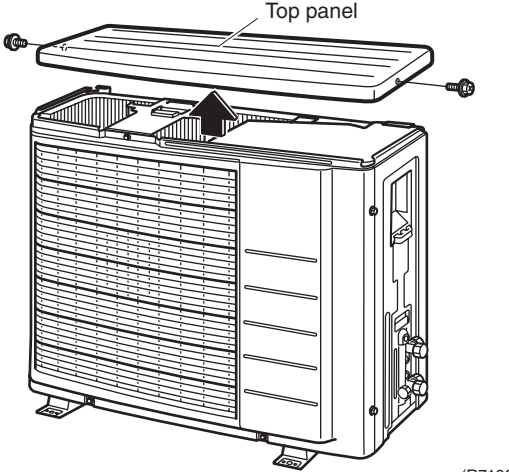
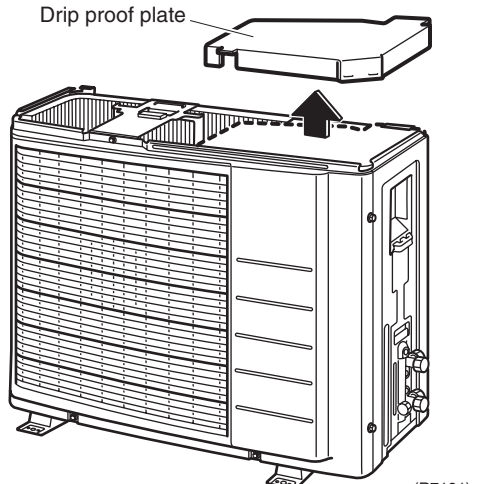
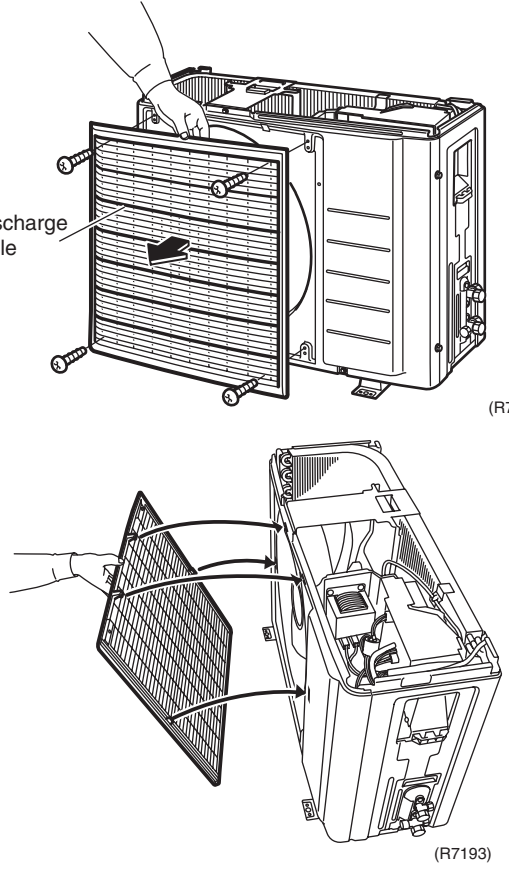
| Step | | Procedure | Points |
|------|--|--|--|
| 2 | Remove the 2 screws and lift the top panel. |  <p>Top panel</p> <p>(R7190)</p> | |
| 3 | Remove the drip proof plate. |  <p>Drip proof plate</p> <p>(R7191)</p> | |
| 4 | Remove the 4 screws and remove the discharge grille. |  <p>Discharge grille</p> <p>(R7192)</p> <p>(R7193)</p> | <p>■ The discharge grille has 4 hooks.</p> |

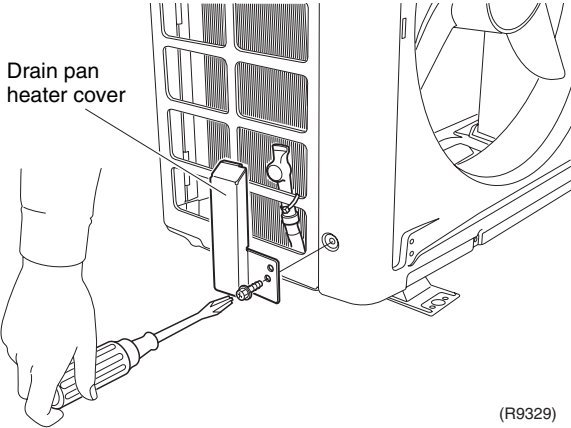
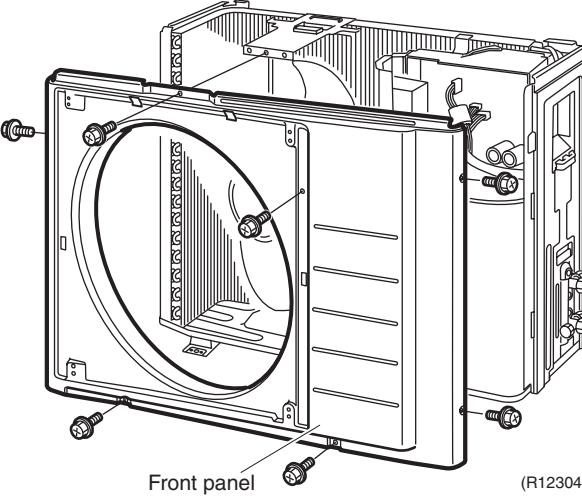
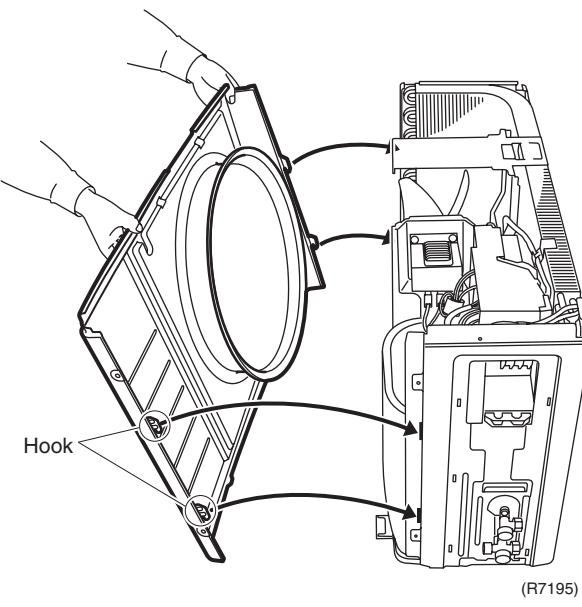
| Step | Procedure | Points |
|------|---|---------------------------------------|
| 5 | Remove the screw and remove the drain pan heater cover. | |
| |  <p>Drain pan heater cover</p> <p>(R9329)</p> | |
| 6 | Remove the 7 screws of the front panel. | |
| |  <p>Front panel</p> <p>(R12304)</p> | |
| 7 | Unfasten the hooks. Pull and remove the front panel. | |
| |  <p>Hook</p> <p>(R7195)</p> | <p>■ The front panel has 4 hooks.</p> |

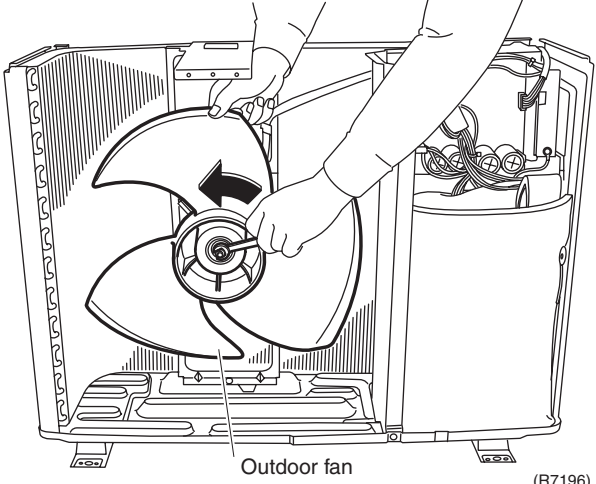
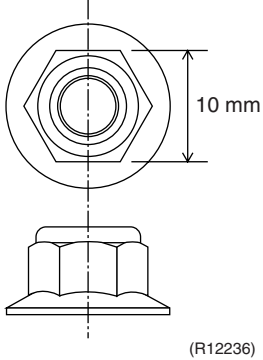
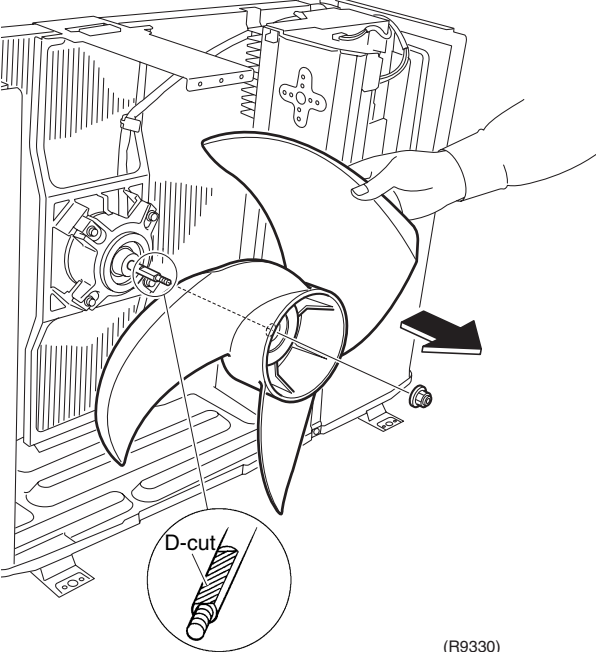
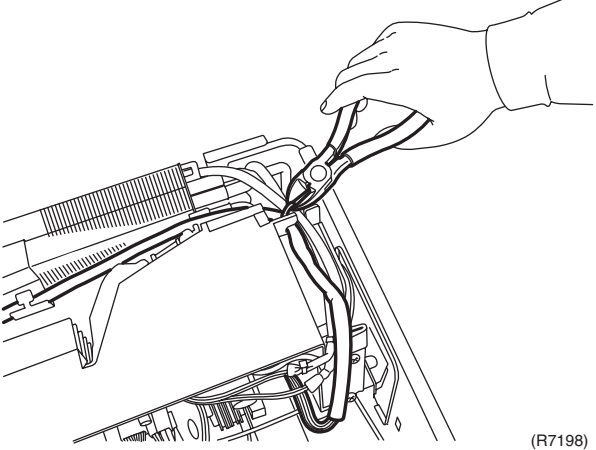
| Step | Procedure | Points |
|--|---|---|
| 3. Remove the fan motor. | | |
| 1 Remove the washer-fitted nut of the outdoor fan. |  <p>Outdoor fan (R7196)</p> | <p>■ Nut size: M6</p>  <p>(R12236)</p> |
| 2 Remove the outdoor fan. |  <p>(R9330)</p> | <p>■ When reassembling, align the ▼ mark of the outdoor fan with the D-cut section of the motor shaft.</p> |
| 3 Cut the clamp. |  <p>(R7198)</p> | |

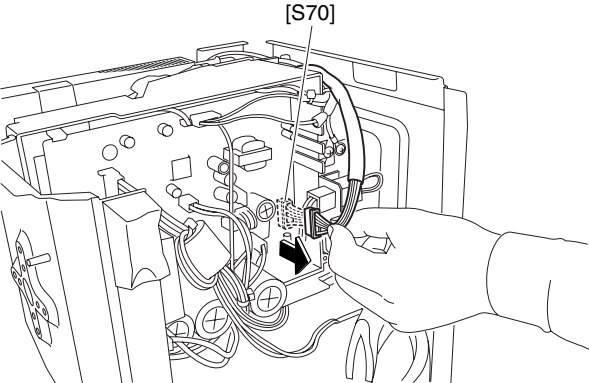
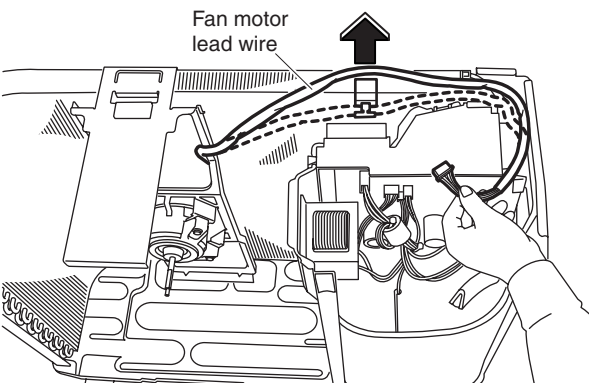
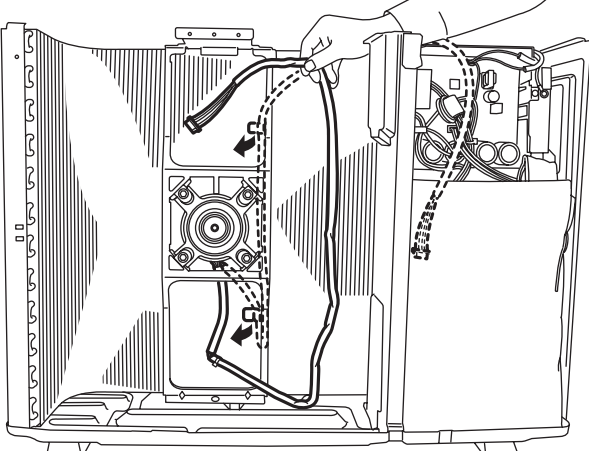
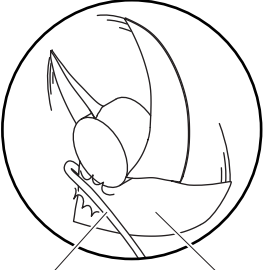
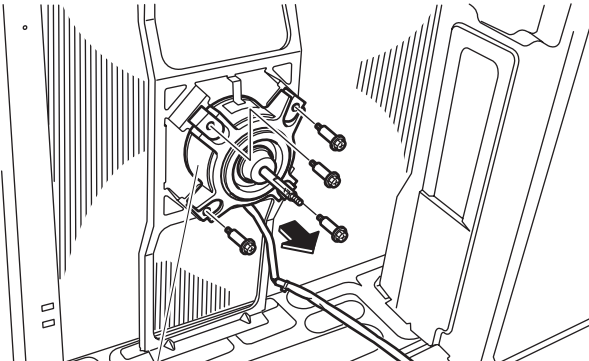
| Step | Procedure | Procedure | Points |
|------|---|---|--|
| 4 | Disconnect the connector for the fan motor [S70]. |  <p>(R9332)</p> | |
| 5 | Release the fan motor lead wire from the hook. |  <p>(R7200)</p> | |
| 6 | Open the hooks and release the fan motor lead wire. |  <p>(R7201)</p> | <ul style="list-style-type: none"> When reassembling, put the fan motor lead wire through the back of the fan motor (so as not to be entangled with the outdoor fan).  <p>Lead wire Outdoor fan (R3249)</p> |
| 7 | Remove the 4 screws and remove the fan motor. |  <p>Fan motor (R7202)</p> | <ul style="list-style-type: none"> Be sure to remove the lower screws first. If the upper screws are removed first, the fan motor, the center of gravity of which is toward the front, may tilt down or fall, getting you injured. |

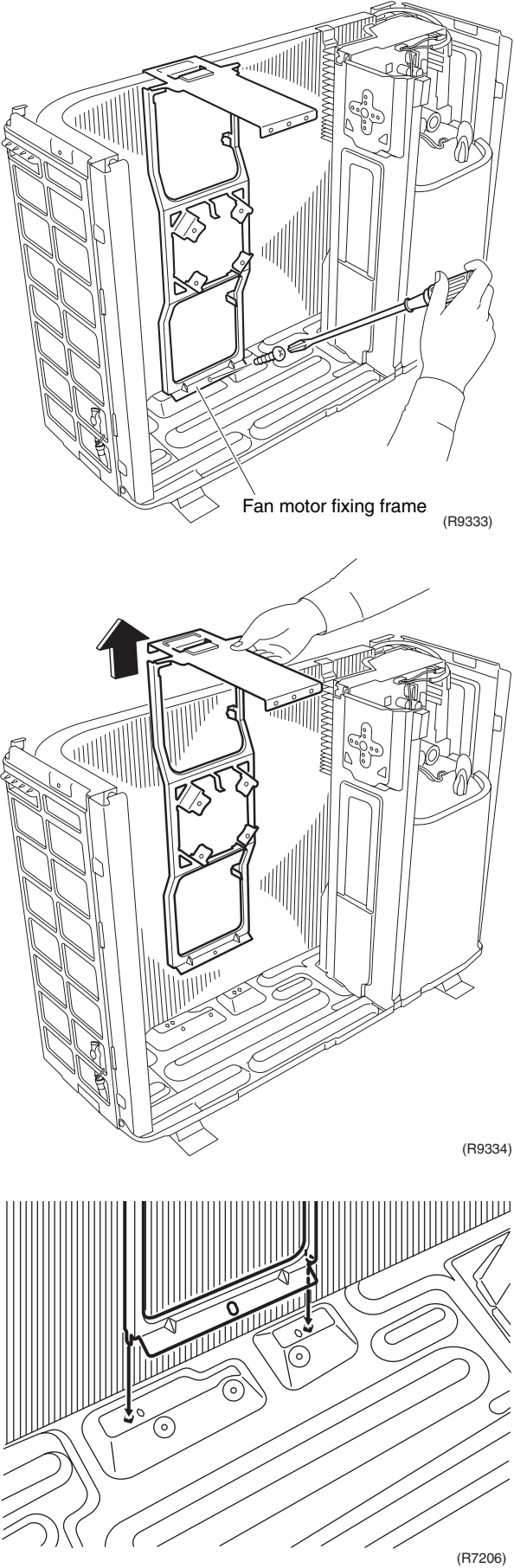
| Step | Procedure | Points |
|----------|--|--|
| <p>8</p> | <p>Remove the screw and remove the fan motor fixing frame.</p>  <p>Fan motor fixing frame (R9333)</p> <p>(R9334)</p> <p>(R7206)</p> | <p>■ When reassembling, fit the lower hooks into the bottom frame.</p> |

| Step | Procedure | Points |
|---------------------------------|--|--------|
| 4. Remove the right side panel. | | |
| 1 | Remove the 2 screws on the rear side. | |
| 2 | Release the outdoor temperature thermistor. | |
| 3 | Lift up the guard net and remove it. | |
| 4 | Remove the 4 screws on the right side panel. | |

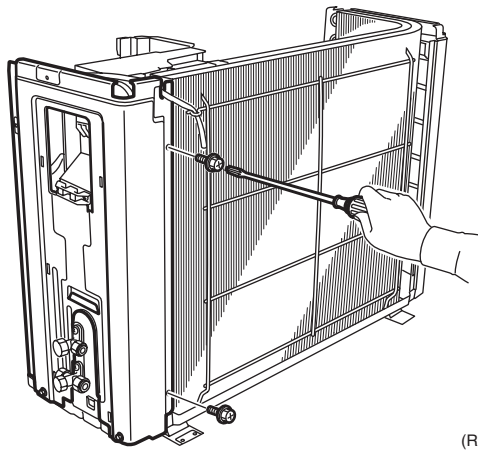

(R7207)

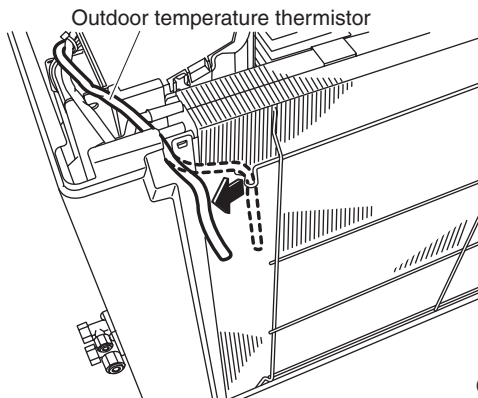

(R7208)

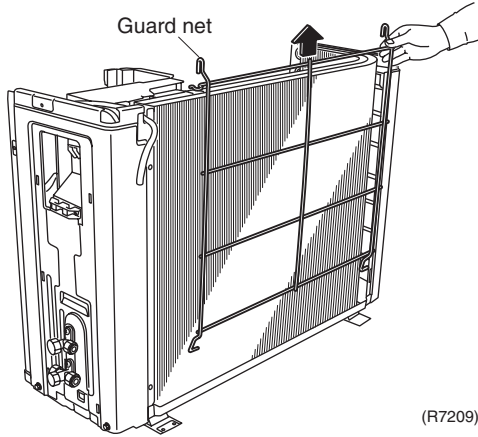

(R7209)

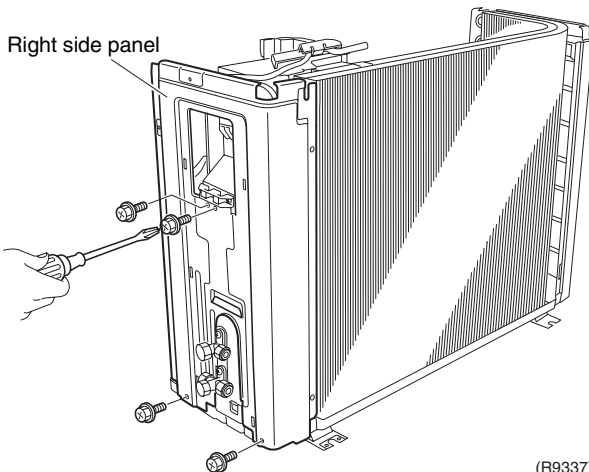

(R9337)

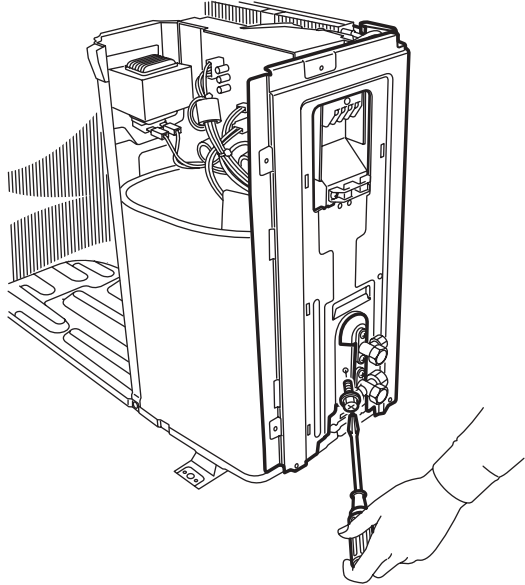
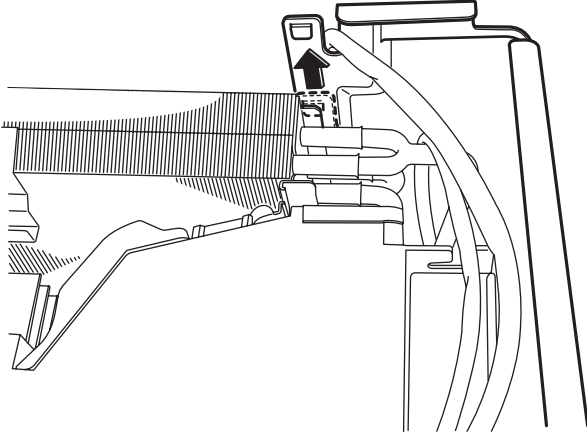
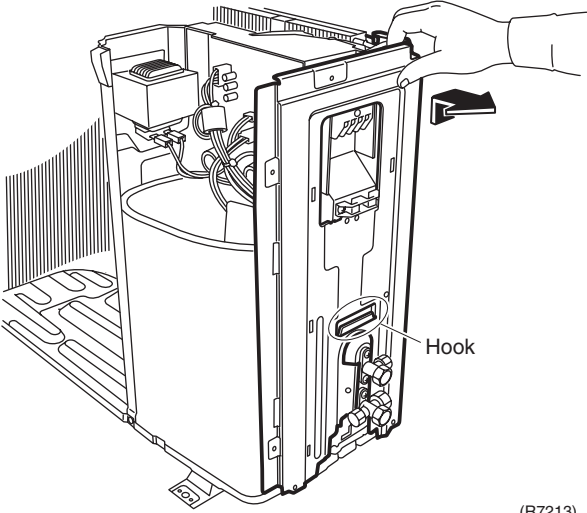
| Step | Procedure | Points |
|------|--|---|
| 5 | <p>Remove the screw near the stop valves.</p>  <p>(R7211)</p> | |
| 6 | <p>Unfasten the hook on the rear side.</p>  <p>(R7212)</p> | <ul style="list-style-type: none"> ■ When reassembling, make sure to fit the hook. |
| 7 | <p>Lift up the right side panel and remove it.</p>  <p>Hook</p> <p>(R7213)</p> | <ul style="list-style-type: none"> ■ When reassembling, make sure to fit the hook. |

2. Removal of Electrical Box

Procedure



Warning Be sure to wait for 10 minutes or more after turning off all power supplies before disassembling work.

| Step | Procedure | Points |
|------|--|--|
| 1 | Disconnect the 2 connectors for the reactor. | <p>Preparation</p> <ul style="list-style-type: none"> Remove the panels and disconnect the connector for the fan motor according to the "Removal of Outer Panels / Fan Motor". |
| 2 | Cut the clamps at 2 locations. | |
| 3 | Disconnect the connector for the compressor [S30]. | |

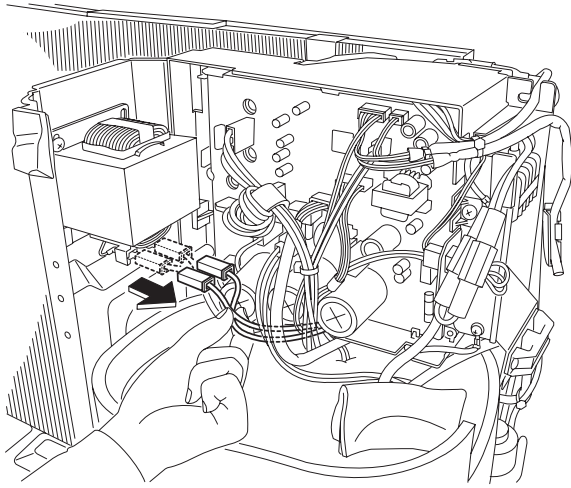

(R9338)

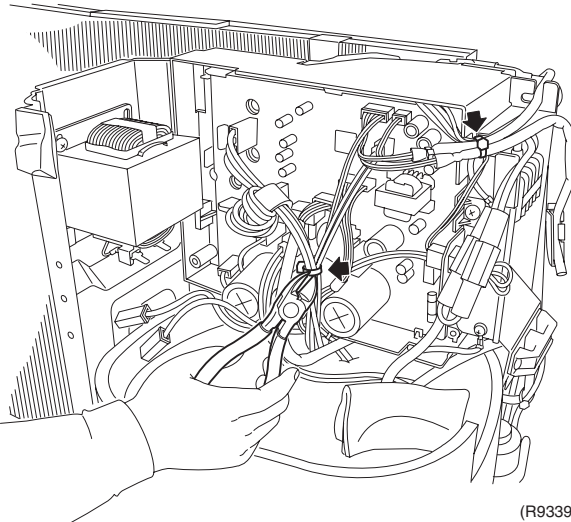

(R9339)

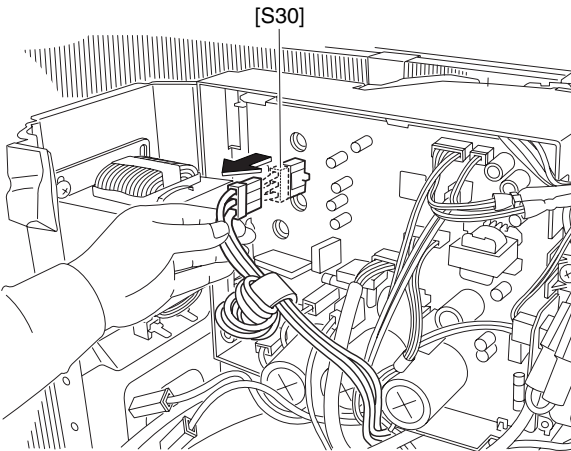

(R9340)

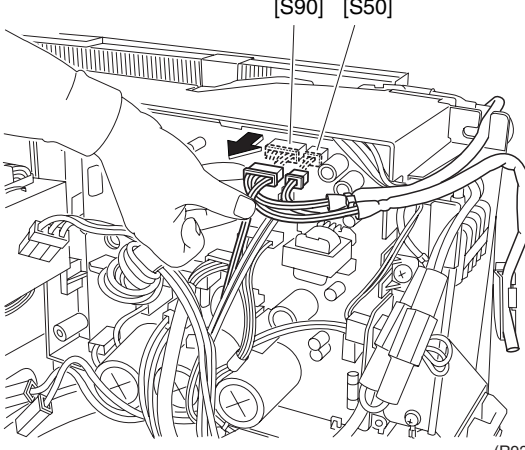
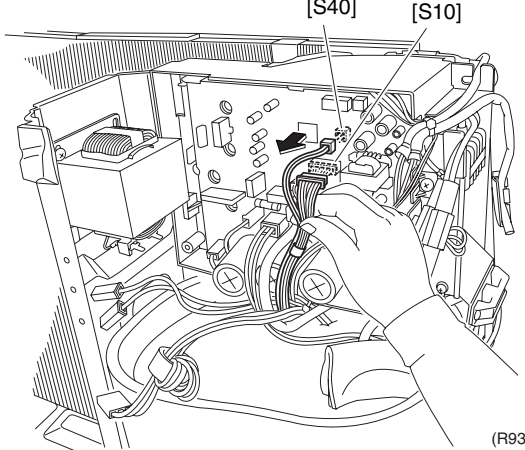
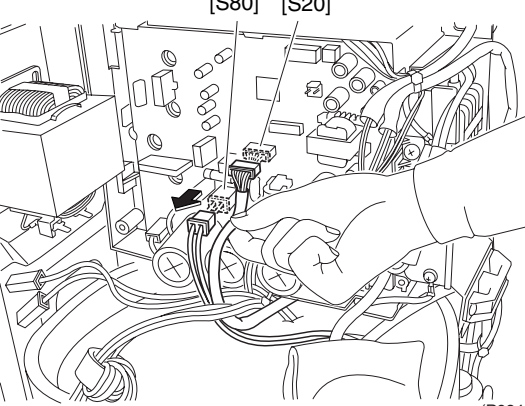
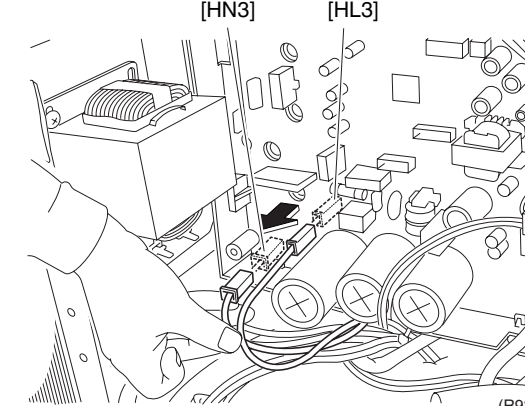
| Step | Procedure | Procedure | Points |
|------|--|---|--------|
| 4 | Disconnect the connectors for the magnetic relay [S50] and for the thermistors [S90]. |  <p>(R9341)</p> | |
| 5 | Disconnect the connectors for the filter PCB [S10] and for the overload protector [S40]. |  <p>(R9342)</p> | |
| 6 | Disconnect the connectors for the electronic expansion valve coil [S20] and for the four way valve coil [S80]. |  <p>(R9343)</p> | |
| 7 | Disconnect the connectors for the filter PCB [HL3] [HN3]. |  <p>(R9344)</p> | |

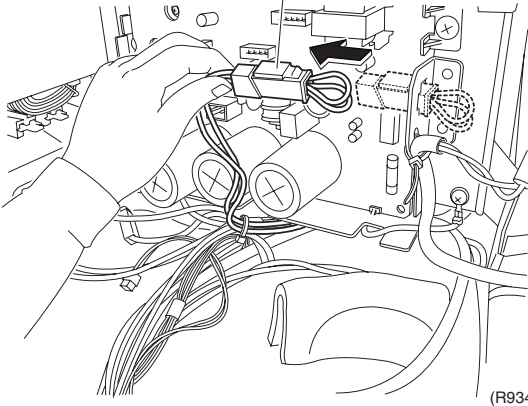
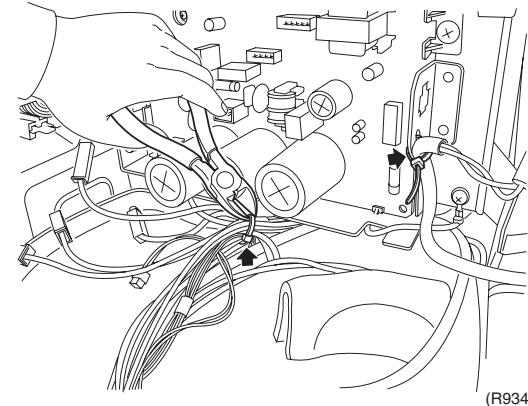
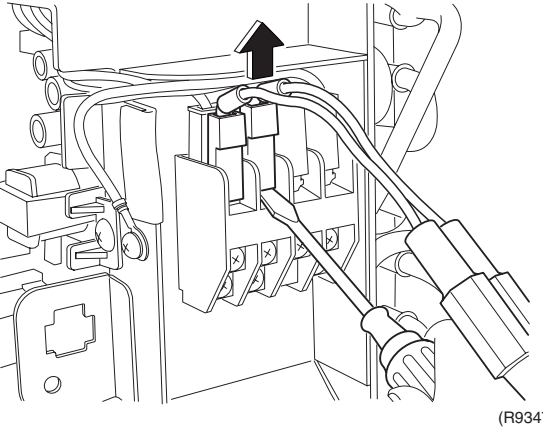
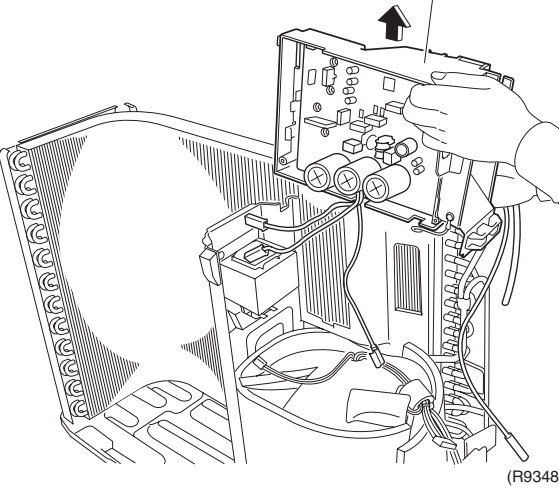
| Step | Procedure | Points |
|------|--|--------|
| 8 | Remove the wire harness for standby electricity saving. | |
| | <p style="text-align: center;">Wire harness</p>  <p style="text-align: right;">(R9345)</p> | |
| 9 | Cut the clamps at 2 locations. | |
| |  <p style="text-align: right;">(R9346)</p> | |
| 10 | Disconnect the connectors for the drain pan heater with a flat screwdriver. | |
| |  <p style="text-align: right;">(R9347)</p> | |
| 11 | Lift and remove the electrical box. | |
| | <p style="text-align: center;">Electrical box</p>  <p style="text-align: right;">(R9348)</p> | |

3. Removal of Drain Pan Heater ASSY

Procedure



Warning Be sure to wait 10 minutes or more after turning off all power supplies before disassembling work.

| Step | Procedure | Points |
|------|---|--|
| 1 | Cut the clamp. | |
| 2 | Remove the screw of the mounting clamp. | |
| 3 | Release the drain pan heater ASSY from the ditch between the bottom frame and the outdoor heat exchanger ASSY. Remove the wire spring with long nose pliers. | <ul style="list-style-type: none"> ■ Take care not to cut your finger by the fins of the outdoor heat exchanger. ■ When reassembling, hang the wire spring to the hair pin cooling tube. |

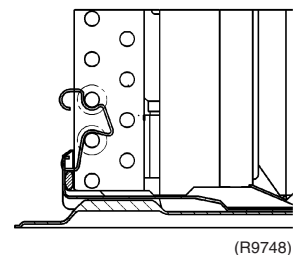
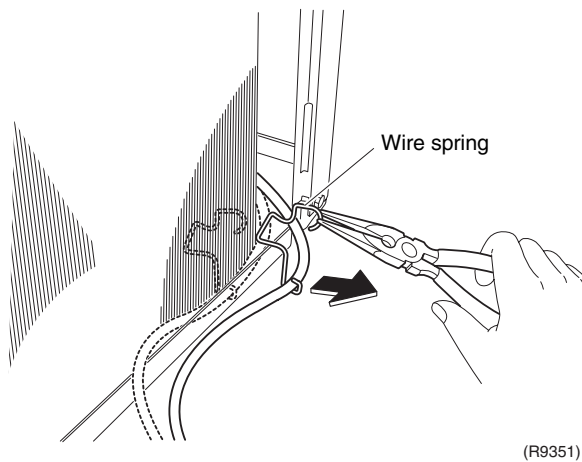
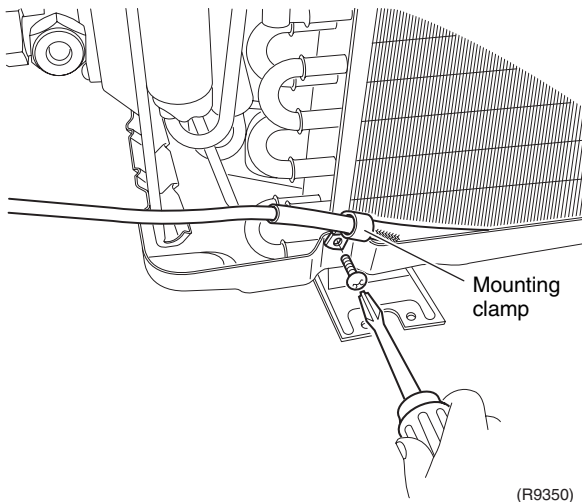
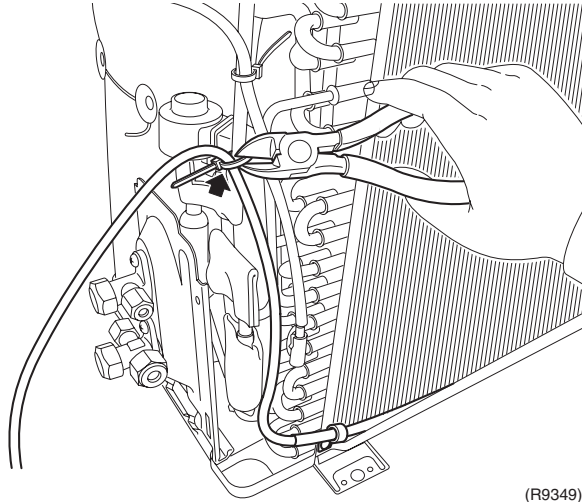

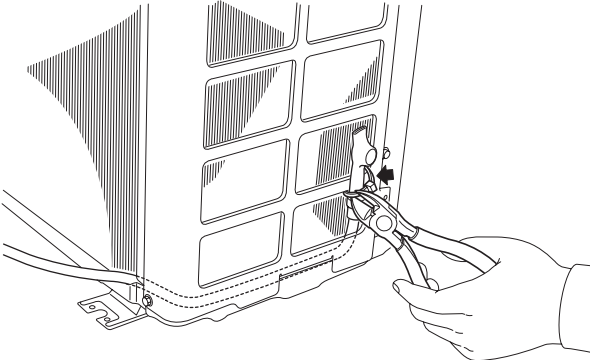
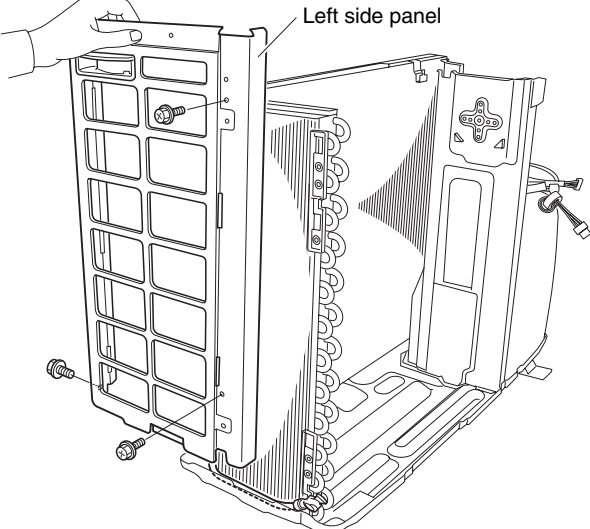
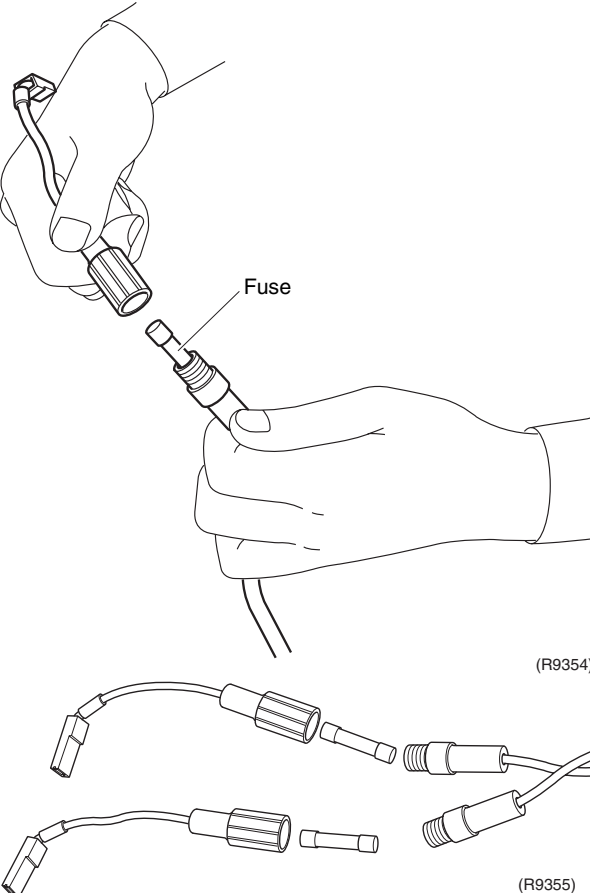
| Step | Procedure | Points |
|------|--|--------|
| 4 | Cut the clamp. | |
| |  <p>(R9352)</p> | |
| 5 | Remove the 3 screws and remove the left side panel. | |
| |  <p>Left side panel</p> <p>(R12307)</p> | |
| 6 | The fuses are inside the drain pan heater. | |
| |  <p>Fuse</p> <p>(R9354)</p> <p>(R9355)</p> | |

4. Removal of Thermistors

Procedure

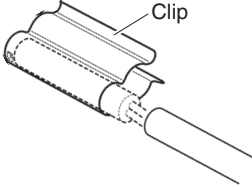
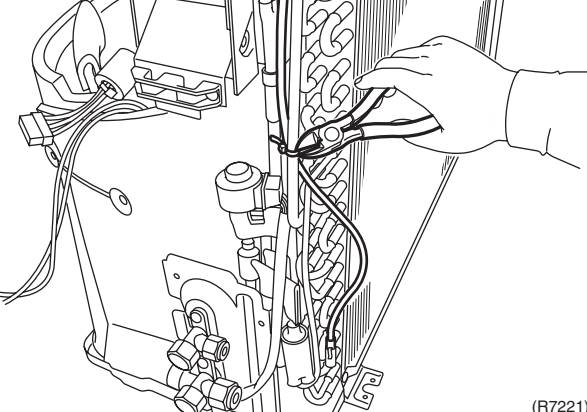
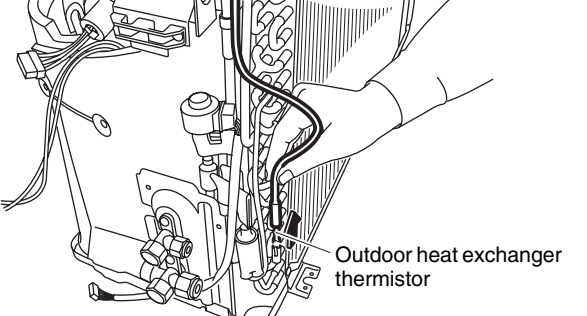
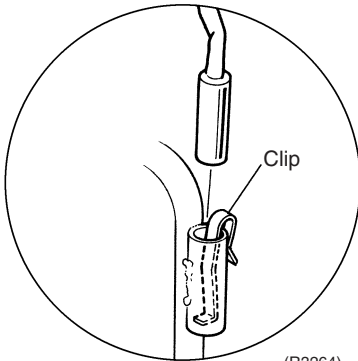
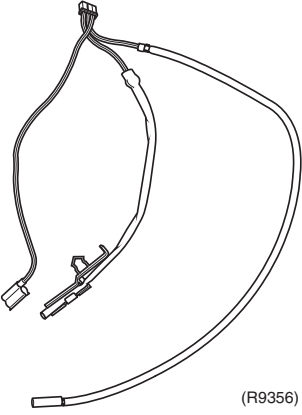

Warning Be sure to wait 10 minutes or more after turning off all power supplies before disassembling work.

| Step | Procedure | Points |
|------|---|--|
| 1 | Release the discharge pipe thermistor. | <p>■ Be careful not to lose the clip for the thermistor.</p>  <p>Clip</p> <p>(R12279)</p> |
| 2 | Cut the clamp. |  <p>Discharge pipe thermistor (R0267)</p> <p>(R7221)</p> |
| 3 | Pull out the outdoor heat exchanger thermistor. | <p>■ Be careful not to lose the clip for the thermistor.</p>  <p>Outdoor heat exchanger thermistor</p> <p>(R7222)</p>  <p>Clip</p> <p>(R3264)</p> |
| 4 | Feature of the thermistors |  <p>(R9356)</p> |

5. Removal of PCB

Procedure

Warning Be sure to wait 10 minutes or more after turning off all power supplies before disassembling work.

| Step | Procedure | Points |
|------|---|---|
| 1 | Feature of the main PCB | <ul style="list-style-type: none"> You can remove the main PCB when you disconnect the lead wires on the terminal board without removing the electrical box. |
| 2 | Remove the screw on the terminal board. | |
| 3 | Release the 2 earth terminals. | |

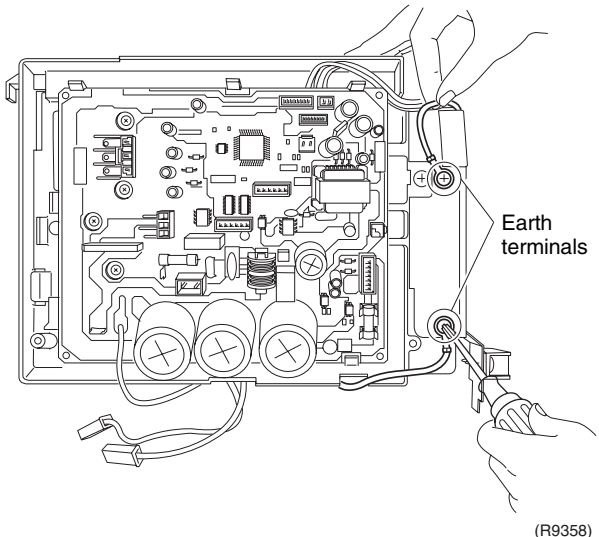
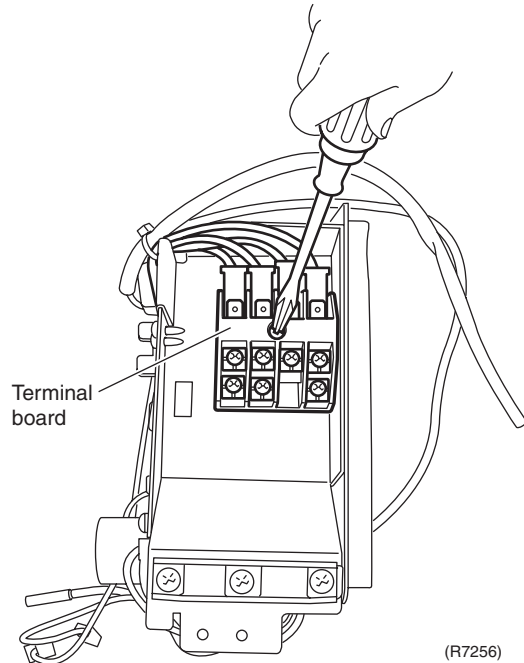
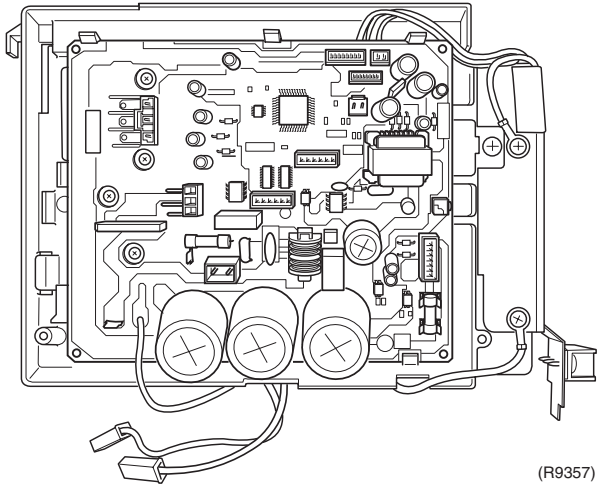

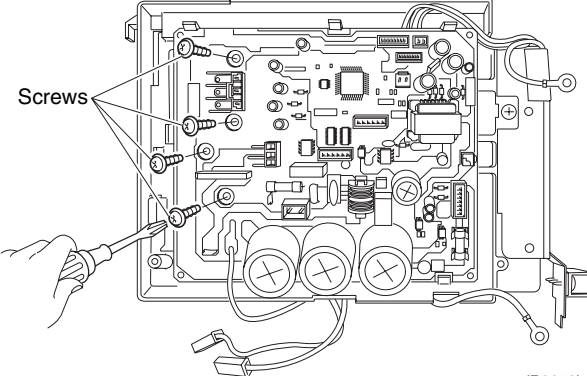
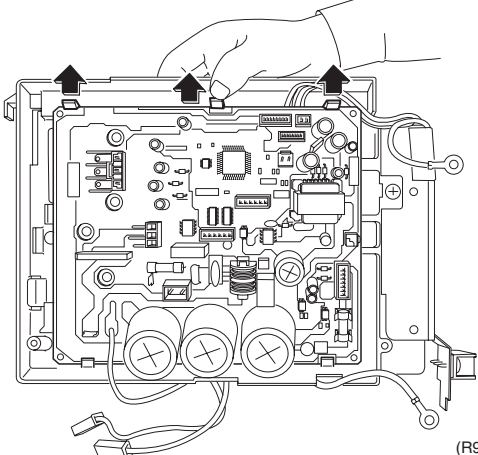
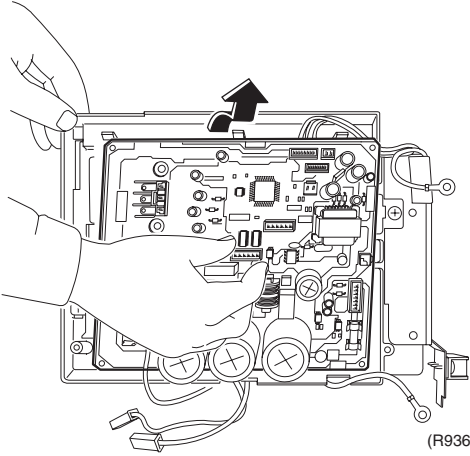
| Step | Procedure | Points |
|------|---|---|
| 4 | <p>Remove the 4 screws.</p>  <p>(R9359)</p> | |
| 5 | <p>Unfasten the 3 hooks on the upper side.</p>  <p>(R9360)</p> | |
| 6 | <p>Lift and pull out the main PCB.</p>  <p>(R9361)</p> | |
| 7 | <p>Feature of the main PCB</p> <p>(R12189)</p> | <p>[S10] [HL3] [HN3]: filter PCB [S20]: electronic expansion valve coil [S30]: compressor [S40]: overload protector [S50]: magnetic relay [S70]: fan motor [S80]: four way valve coil [S90]: thermistors</p> |

6. Removal of Reactor / Partition Plate

Procedure

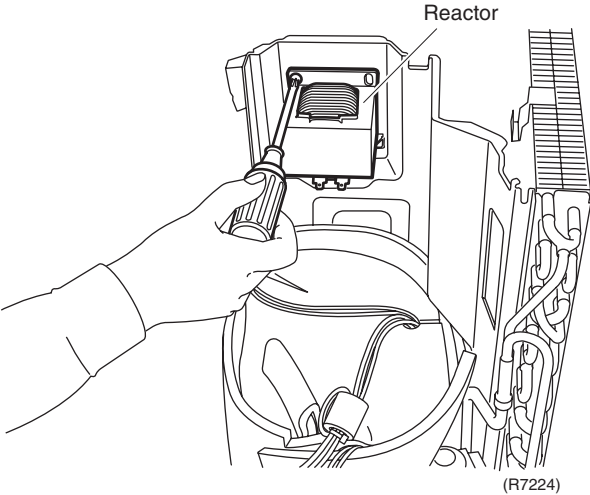
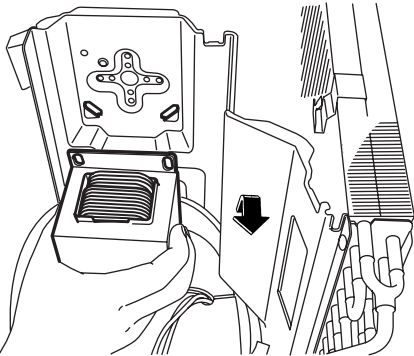
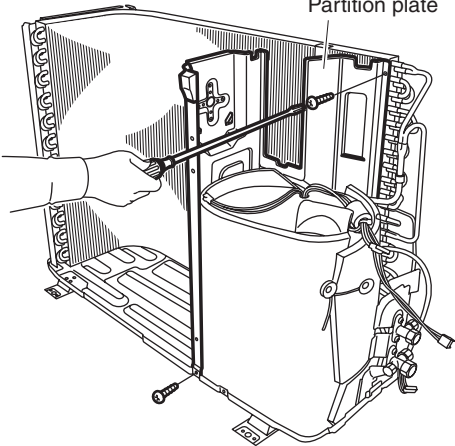

Warning Be sure to wait 10 minutes or more after turning off all power supplies before disassembling work.

| Step | Procedure | Points |
|---|---|--|
| <p>1. Remove the reactor.</p> <p>1 Remove the screw and remove the reactor.</p> |  <p>(R7224)</p>  <p>(R7225)</p> | <p>Preparation</p> <ul style="list-style-type: none"> ■ Remove the outer panels according to the "Removal of Outer Panels / Fan Motor". ■ Remove the electrical box according to the "Removal of Electrical Box". |
| <p>2. Remove the partition plate.</p> <p>1 Remove the 2 screws.</p> |  <p>(R7226)</p> | |

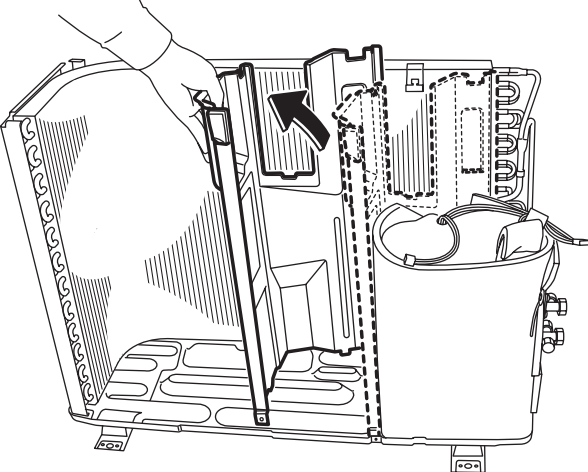
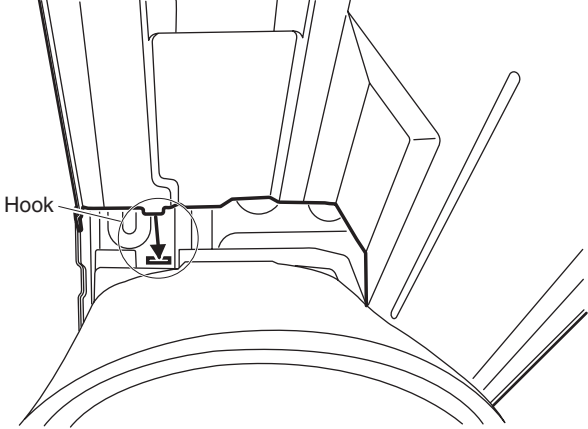
| Step | Procedure | Points |
|------|---|--|
| 2 | <p data-bbox="199 219 454 376">The partition plate has a hook on the lower side. Lift and pull the partition plate to remove.</p>  <p data-bbox="1013 712 1077 739">(R7227)</p>  <p data-bbox="486 963 550 990">Hook</p> <p data-bbox="997 1220 1061 1247">(R7228)</p> | <ul style="list-style-type: none"> <li data-bbox="1093 757 1444 851">■ When reassembling, fit the lower hook into the bottom frame. |

7. Removal of Sound Blankets

Procedure



Warning Be sure to wait for 10 minutes or more after turning off all power supplies before disassembling work.

| Step | Procedure | Points |
|------|--|--|
| 1 | Untie the string and open the sound blanket (outer). | <p>Preparation</p> <ul style="list-style-type: none"> ■ Remove the outer panels according to the "Removal of Outer Panels / Fan Motor". ■ Remove the electrical box according to the "Removal of Electrical Box". |
| 2 | Lift and remove the sound blanket (outer). | <ul style="list-style-type: none"> ■ Since the piping ports are torn easily, remove the sound blanket carefully. |
| 3 | Remove the sound blanket (top). | |
| 4 | Pull the sound blanket (inner) out. | |

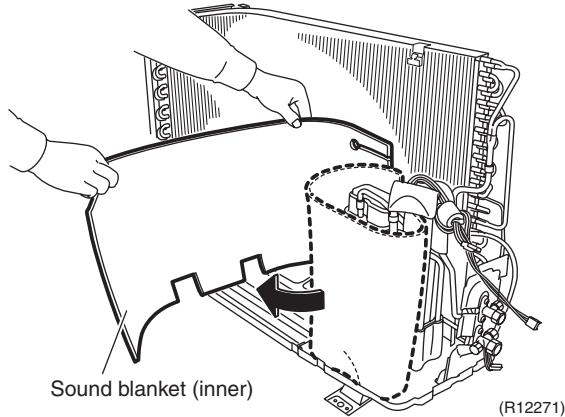
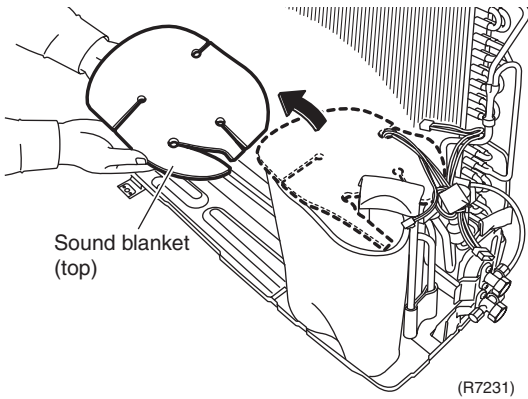
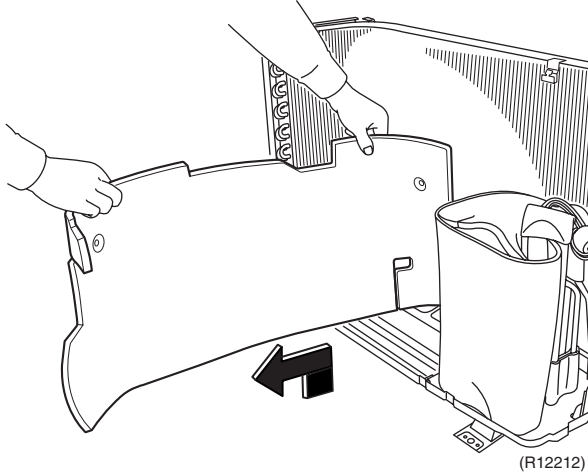
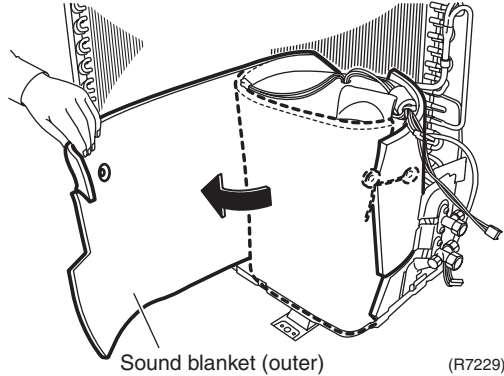

8. Removal of Four Way Valve

Procedure



Warning Be sure to wait for 10 minutes or more after turning off all power supplies before disassembling work.

| Step | Procedure | Points |
|------|---|-----------------------------------|
| 1 | Pull out the electronic expansion valve coil. | Electronic expansion valve coil |
| 2 | Remove the terminal cover. | Terminal cover |
| 3 | Disconnect the lead wires of the compressor. | Red (U) Yellow (V) Blue (W) |

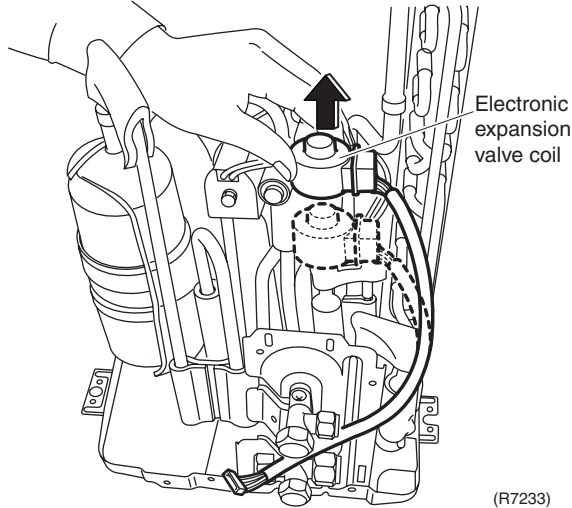

(R7233)

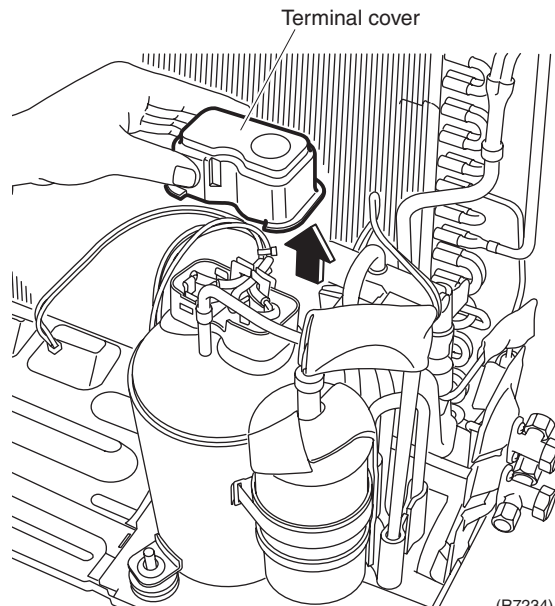

(R7234)

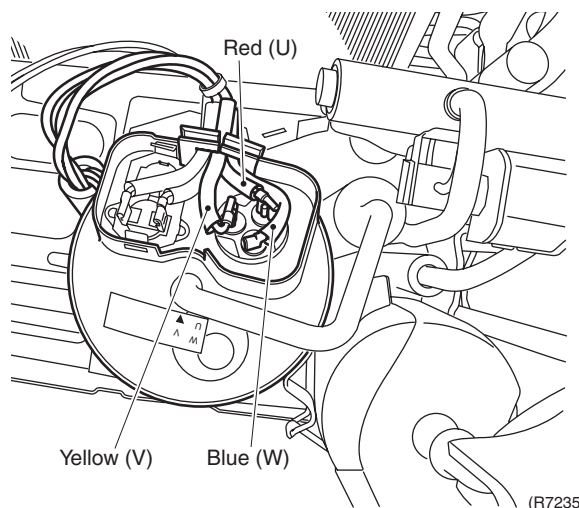

(R7235)

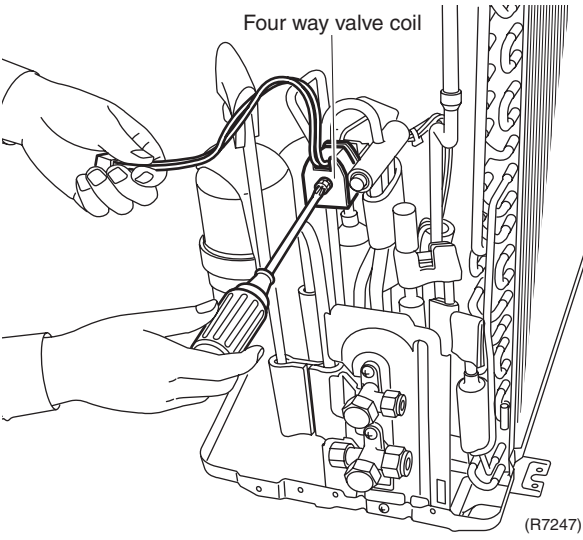
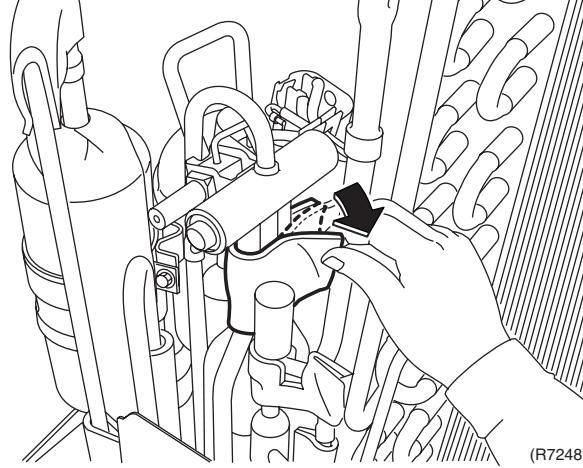
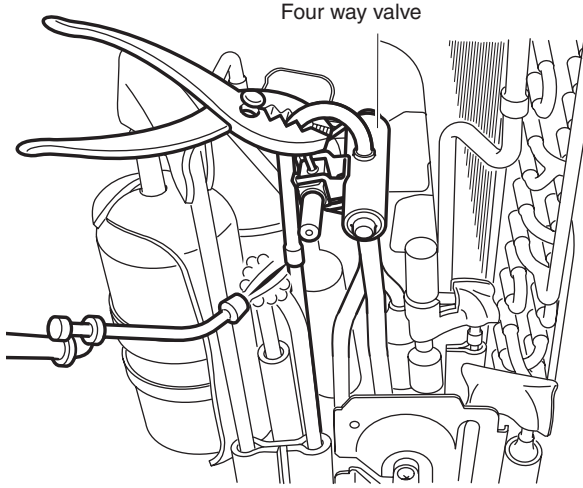
| Step | Procedure | Points |
|---|---|---|
| <p>4 Remove the screw and remove the four way valve coil.</p> |  <p style="text-align: center;">Four way valve coil</p> <p style="text-align: right;">(R7247)</p> | <p>Warning Be careful not to get yourself burnt with the pipes and other parts that are heated by the gas brazing machine.</p> <p>Warning If the refrigerant gas leaks during work, ventilate the room. (If the refrigerant gas is exposed to flames, toxic gas may be generated.)</p> <p>Caution From the viewpoint of global environment protection, do not discharge the refrigerant gas in the atmosphere. Make sure to collect all the refrigerant gas.</p> <p>Cautions for restoration</p> <ol style="list-style-type: none"> 1. Restore the piping by non-oxidation brazing. 2. It is required to prevent the carbonization of the oil inside the four way valve and the deterioration of the gaskets affected by heat. (Keep below 120°C.) For the sake of this, wrap the four way valve with wet cloth and provide water so that the cloth does not dry. |
| <p>5 Remove the sheets of putty.</p> |  <p style="text-align: right;">(R7248)</p> | <p>In case of difficulty with gas brazing machine</p> <ol style="list-style-type: none"> 1. Disconnect the brazed part where is easy to disconnect and restore. 2. Cut pipes on the main unit with a tube cutter in order to make it easy to disconnect. |
| <ul style="list-style-type: none"> ■ Before working, make sure that the refrigerant gas is empty in the circuit. ■ Be sure to apply nitrogen replacement when heating up the brazed part. |  <p style="text-align: center;">Four way valve</p> <p style="text-align: right;">(R7249)</p> | |
| <p>6 Heat up the brazed part and withdraw the piping with pliers.</p> | | |

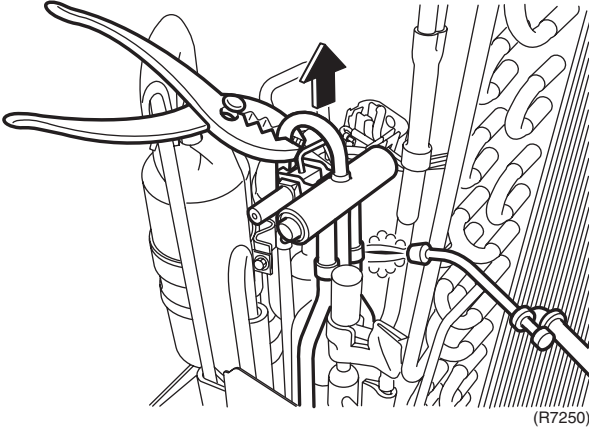
| Step | Procedure | Points |
|------|---|--|
| |  <p>(R7250)</p> | <p>Note:</p> <ul style="list-style-type: none">■ Do not use a metal saw for cutting pipes by all means because the sawdust comes into the circuit.■ When withdrawing the pipes, be careful not to pinch them firmly with pliers. The pipes may get deformed.■ Provide a protective sheet or a steel plate so that the brazing flame cannot influence peripheries. |

9. Removal of Compressor

Procedure

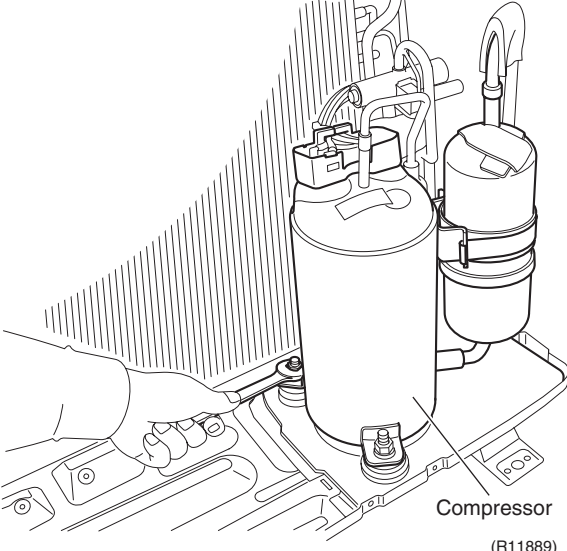
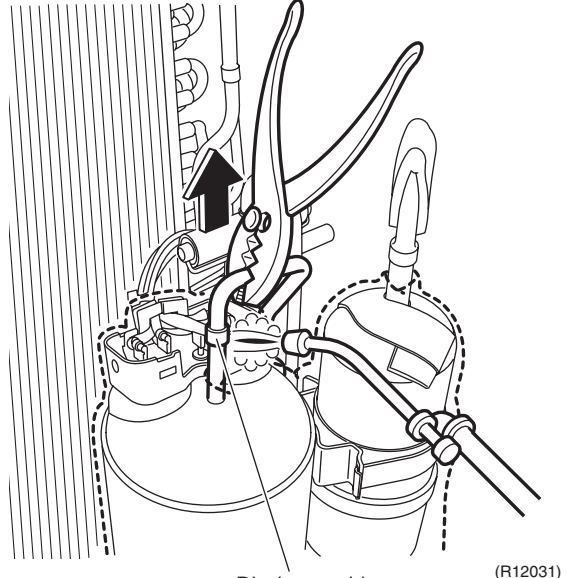

Warning Be sure to wait for 10 minutes or more after turning off all power supplies before disassembling work.

| Step | Procedure | Points |
|---|--|---|
| 1 | <p>Remove the 2 nuts of the compressor.</p>  | <p>Warning Be careful not to get yourself burnt with the pipes and other parts that are heated by the gas brazing machine.</p> <p>Warning If the refrigerant gas leaks during work, ventilate the room. (If the refrigerant gas is exposed to flames, toxic gas may be generated.)</p> <p>Warning Since it may happen that the refrigerant oil in the compressor catches fire, prepare wet cloth so as to extinguish fire immediately.</p> |
| <ul style="list-style-type: none"> ■ Before working, make sure that the refrigerant is empty in the circuit. ■ Be sure to apply nitrogen replacement when heating up the brazed part. |  | <p>Caution From the viewpoint of global environment protection, do not discharge the refrigerant gas in the atmosphere. Make sure to collect all the refrigerant gas.</p> |
| 2 | <p>Heat up the brazed part of the discharge side and disconnect.</p> | <p>Cautions for restoration</p> <ol style="list-style-type: none"> 1. Restore the piping by non-oxidation brazing. 2. It is required to prevent the carbonization of the oil inside the four way valve and the deterioration of the gaskets affected by heat. (Keep below 120°C.) For the sake of this, wrap the four way valve with wet cloth and provide water so that the cloth does not dry. <p>In case of difficulty with gas brazing machine</p> <ol style="list-style-type: none"> 1. Disconnect the brazed part where is easy to disconnect and restore. 2. Cut pipes on the main unit with a tube cutter in order to make it easy to disconnect. |

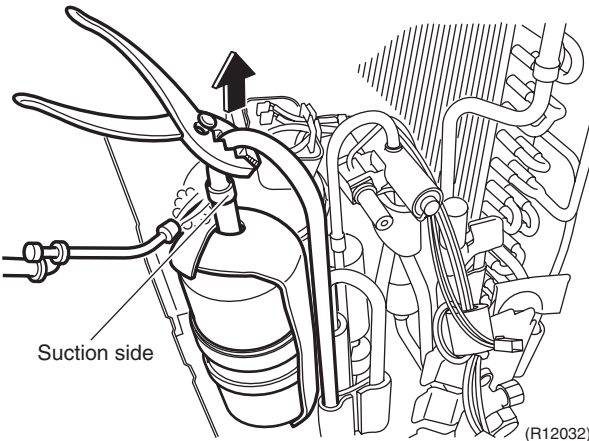
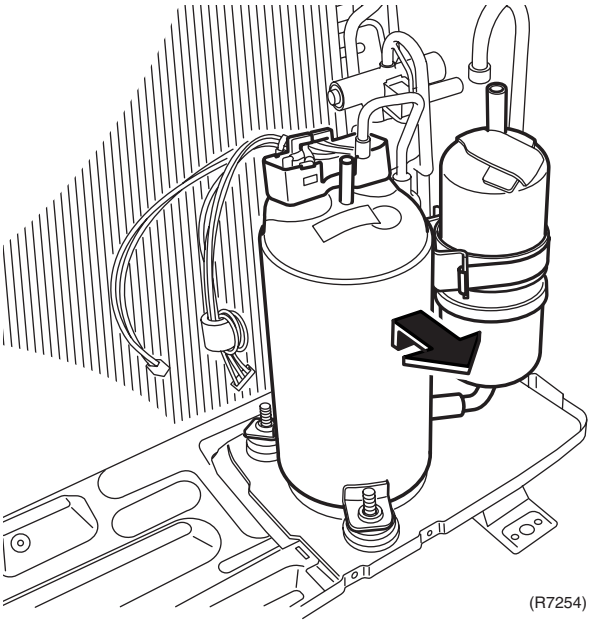
| Step | Procedure | Points |
|------|---|---|
| 3 | Heat up the brazed part of the suction side and disconnect.  <p style="text-align: right;">(R12032)</p> | Note: <ul style="list-style-type: none"> ■ Do not use a metal saw for cutting pipes by all means because the sawdust comes into the circuit. ■ When withdrawing the pipes, be careful not to pinch them firmly with pliers. The pipes may get deformed. ■ Provide a protective sheet or a steel plate so that the brazing flame cannot influence peripheries. |
| 4 | Lift the compressor up and remove it.  <p style="text-align: right;">(R7254)</p> | <ul style="list-style-type: none"> ■ Be careful so as not to burn the compressor terminals, the name plate, the heat exchanger fin. |

Revision History

| Month / Year | Version | Revised contents |
|--------------|----------|------------------|
| 02 / 2013 | Si00-971 | First edition |

Warning



- Daikin products are manufactured for export to numerous countries throughout the world. Prior to purchase, please confirm with your local authorised importer, distributor and/or retailer whether this product conforms to the applicable standards, and is suitable for use, in the region where the product will be used. This statement does not purport to exclude, restrict or modify the application of any local legislation.
- Ask a qualified installer or contractor to install this product. Do not try to install the product yourself. Improper installation can result in water or refrigerant leakage, electrical shock, fire or explosion.
- Use only those parts and accessories supplied or specified by Daikin. Ask a qualified installer or contractor to install those parts and accessories. Use of unauthorised parts and accessories or improper installation of parts and accessories can result in water or refrigerant leakage, electrical shock, fire or explosion.
- Read the User's Manual carefully before using this product. The User's Manual provides important safety instructions and warnings. Be sure to follow these instructions and warnings.

If you have any enquiries, please contact your local importer, distributor and/or retailer.

Cautions on product corrosion

1. Air conditioners should not be installed in areas where corrosive gases, such as acid gas or alkaline gas, are produced.
2. If the outdoor unit is to be installed close to the sea shore, direct exposure to the sea breeze should be avoided. If you need to install the outdoor unit close to the sea shore, contact your local distributor.

Dealer

DAIKIN INDUSTRIES, LTD.

Head Office:
Umeda Center Bldg., 2-4-12, Nakazaki-Nishi,
Kita-ku, Osaka, 530-8323 Japan

Tokyo Office:
JR Shinagawa East Bldg., 2-18-1, Konan,
Minato-ku, Tokyo, 108-0075 Japan

http://www.daikin.com/global_ac/

©All rights reserved