



REMOVAL PROCEDURE



SERVICE
MANUAL

S E R V I C E M A N U A L

7.1/8.0/9.0 kW Class

-  Outdoor Unit
-  Inverter / Hybrid
-  Pair Type



Service Manual Removal Procedure

Outdoor Unit

●Cooling Only

RKS71FBVMA

RKS71FVMA

●Heat Pump

RXS71FBVMA

RXS80FBVMA

RXS71FVMA

RXS80FVMA

RXS90FVMA

RYN71FV1A

Table of Contents

1. Removal of Outer Panels	2
2. Removal of Electrical Box	13
3. Removal of PCBs	17
4. Removal of Fan Motor.....	20
5. Removal of Coils / Thermistors	21
6. Removal of Sound Blankets.....	24
7. Removal of Compressor	27



Note:

- The illustrations may be slightly different depending on the model.
- The illustrations are for heat pump models as representative.

1. Removal of Outer Panels

Procedure

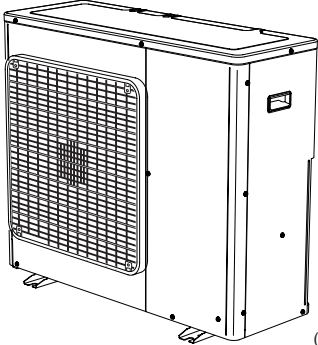
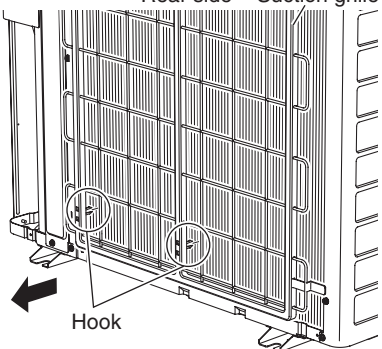
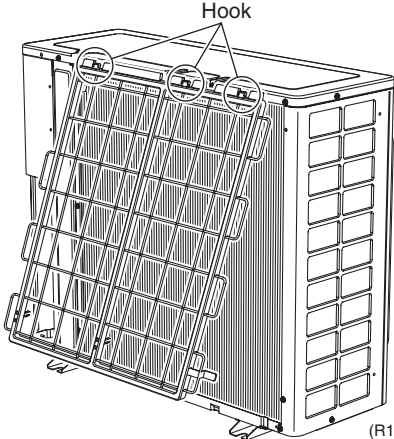
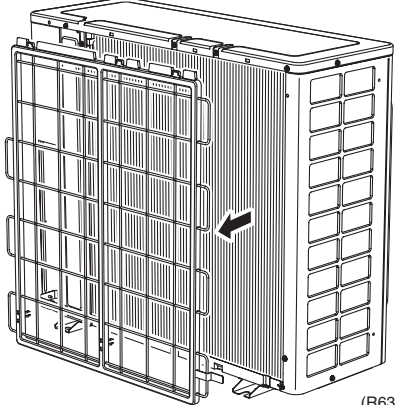

Warning Be sure to wait for 10 minutes or more after turning off all power supplies before disassembling work.

Step	Procedure	Points
1. Appearance features	 <p style="text-align: right;">(R16722)</p>	<ul style="list-style-type: none"> ■ The design of discharge grille is different depending on the model.
2. Remove the suction grille.	<p>1 Unfasten the 2 hooks at the bottom first.</p>  <p style="text-align: right;">(R16916)</p> <p>2 Slide the suction grille downward to unfasten the 3 top hooks.</p>  <p style="text-align: right;">(R16917)</p> <p>3 Remove the suction grille.</p>  <p style="text-align: right;">(R6372)</p>	<ul style="list-style-type: none"> ■ The hooks are secured in the clearances of the outdoor heat exchanger fins.

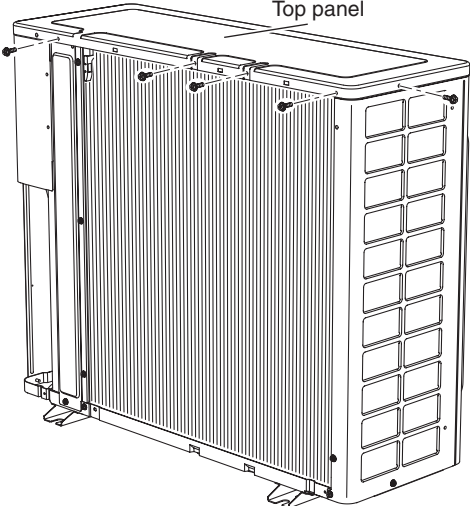
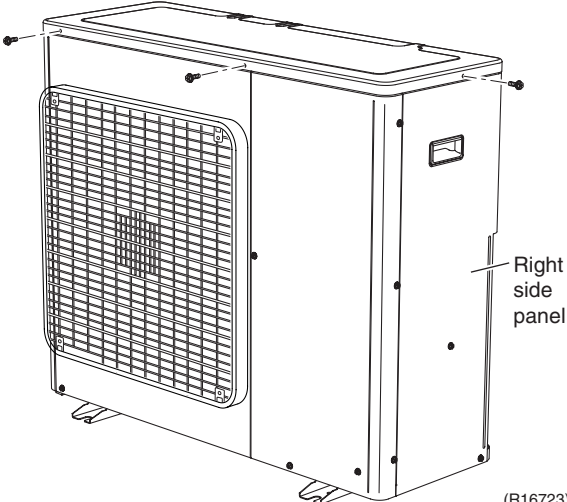
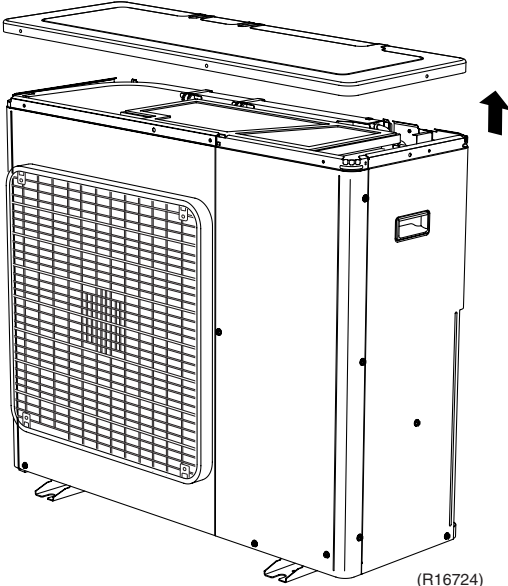
Step	Procedure	Points
3. Remove the top panel.	<p data-bbox="153 248 448 344">1 Remove the 4 screws on the back and the screw on the left side.</p>  <p data-bbox="810 255 906 277">Top panel</p> <p data-bbox="943 770 1002 792">(R6373)</p> <p data-bbox="153 801 456 927">2 Remove the 2 screws on the front and the screw on the right side panel.</p>  <p data-bbox="1007 1099 1066 1173">Right side panel</p> <p data-bbox="999 1335 1066 1357">(R16723)</p> <p data-bbox="153 1375 440 1435">3 Lift the top panel and remove it.</p>  <p data-bbox="943 1991 1018 2013">(R16724)</p>	

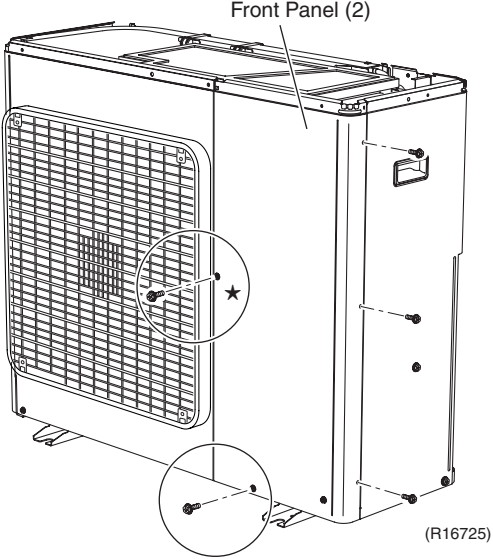
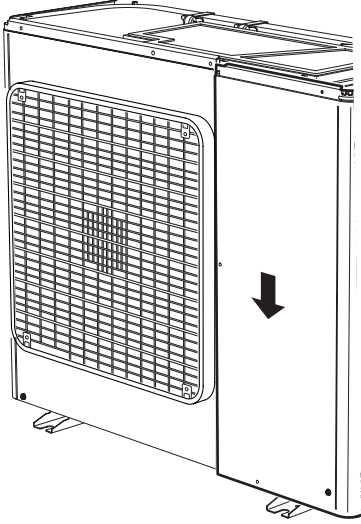
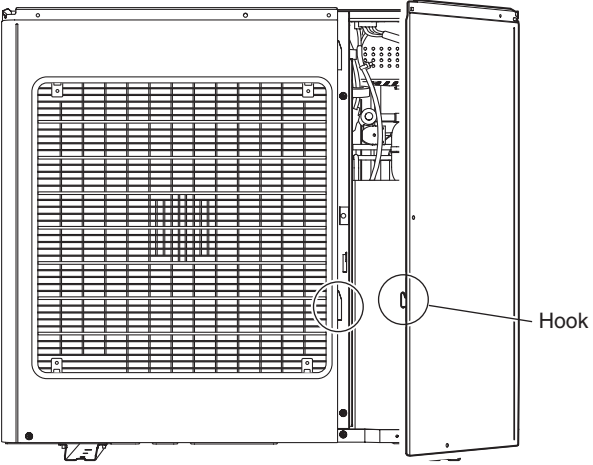
Step	Procedure	Points
4. Remove the front panel (2).		
1 Remove the 5 screws.	 <p style="text-align: center;">Front Panel (2)</p> <p style="text-align: right;">(R16725)</p>	<p>★: This screw is M5(3) × 16</p>
2 Slide the front panel (2) downward to unfasten the hook.	 <p style="text-align: right;">(R16726)</p>	
3 Remove the front panel (2).	 <p style="text-align: right;">Hook</p> <p style="text-align: right;">(R16727)</p>	

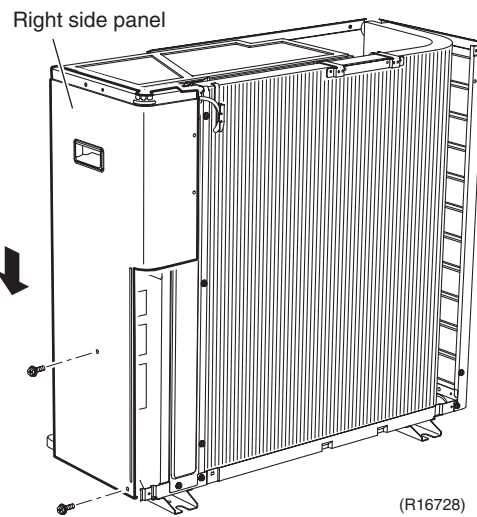
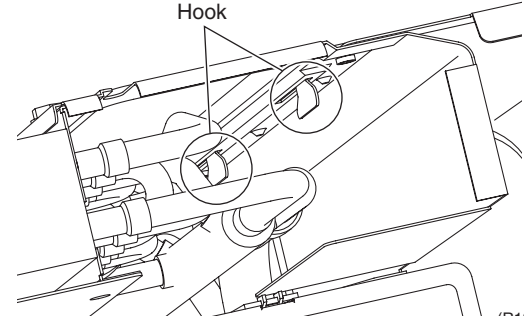
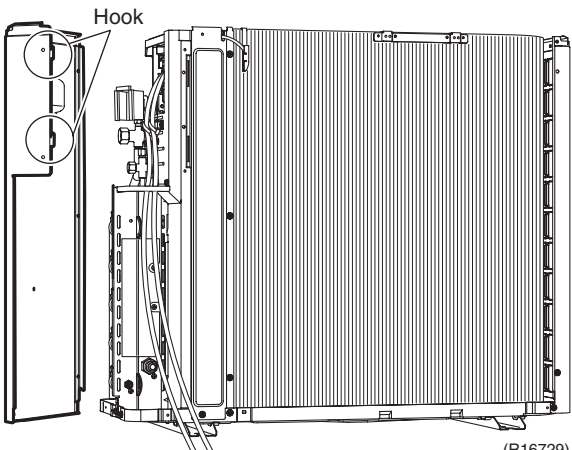
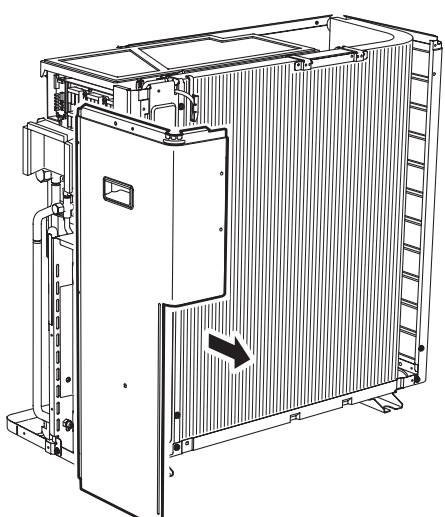
Step	Procedure	Points
<p>5. Remove the right side panel.</p> <p>1</p>	<p>Remove the 2 screws. Slide the right side panel downward to unfasten the 2 hooks on the rear side.</p>  <p>Right side panel</p> <p>(R16728)</p>  <p>Hook</p> <p>(R13521)</p>  <p>Hook</p> <p>(R16729)</p> <p>2</p> <p>Remove the right side panel.</p>  <p>(R16730)</p>	

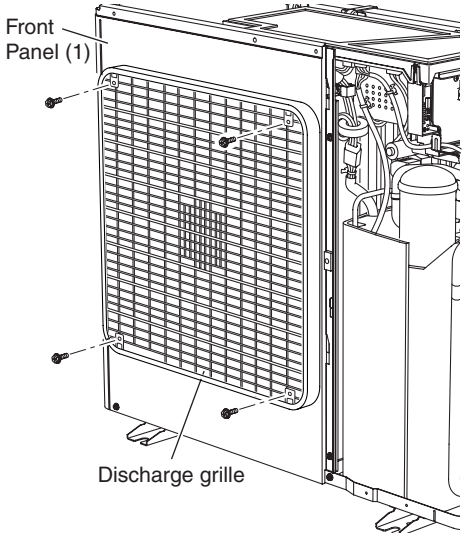
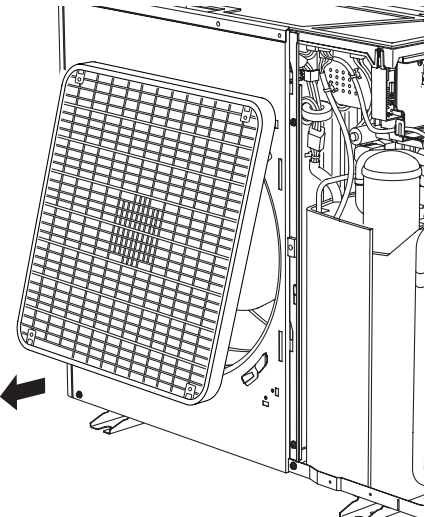
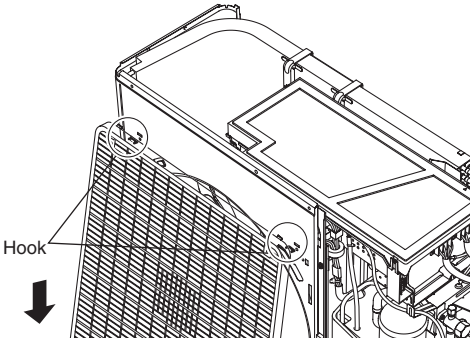
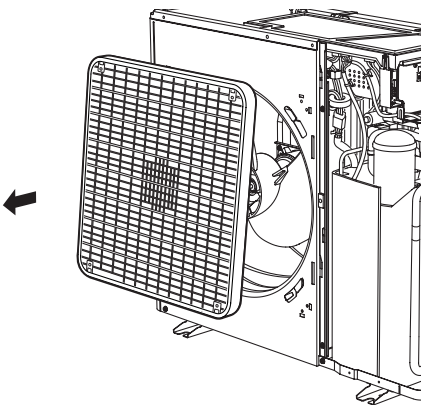
Step	Procedure	Points
6. Remove the front panel (1).		
1 Remove the 4 screws on the discharge grille.	 <p>Front Panel (1)</p> <p>Discharge grille</p> <p>(R16731)</p>	<ul style="list-style-type: none"> Remove the discharge grille and the outdoor fan first to remove the front panel (1).
2 Pull the bottom of the discharge grille.	 <p>(R16732)</p>	
3 Slide the discharge grille downward to unfasten the 2 hooks at the top.	 <p>Hook</p> <p>(R16734)</p>	
4 Remove the discharge grille.	 <p>(R16735)</p>	

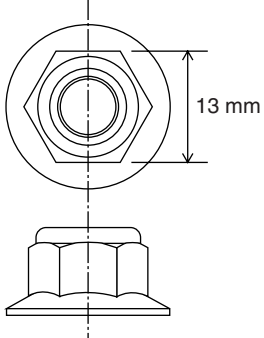
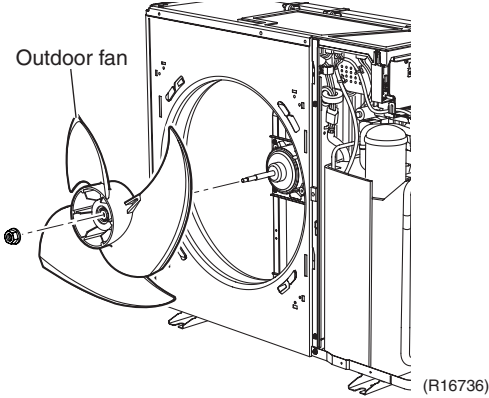
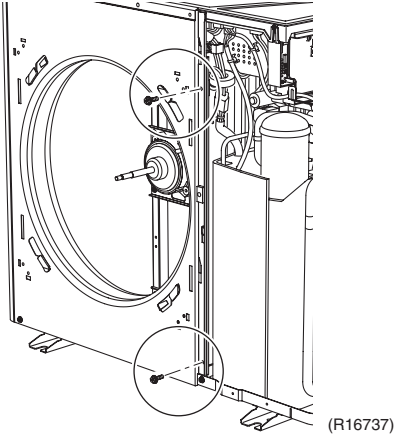
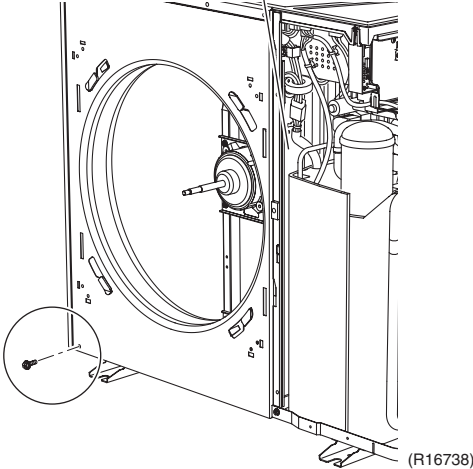
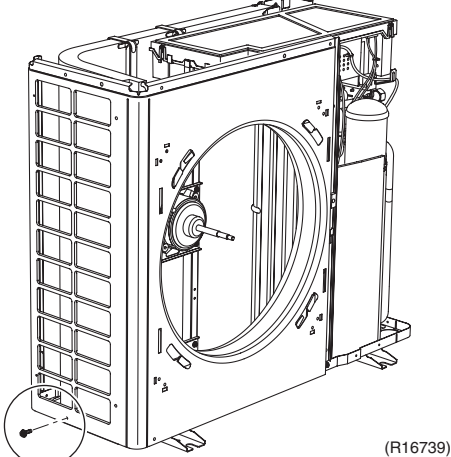
Step	Procedure	Points
5	Remove the nut of the outdoor fan.	<p>■ Nut size : M8</p>  <p>(R12301)</p>
6	Remove the 2 screws on the partition plate (1).	 <p>(R16736)</p>  <p>(R16737)</p>
7	Remove the screw at the bottom left of the front.	 <p>(R16738)</p>
8	Remove the screw at the bottom of the left side.	 <p>(R16739)</p>

Step	Procedure	Points
9	Remove the screw at the bottom of the rear side.	
10	Lift the front panel (1) to unfasten the hook.	
11	Remove the front panel (1).	

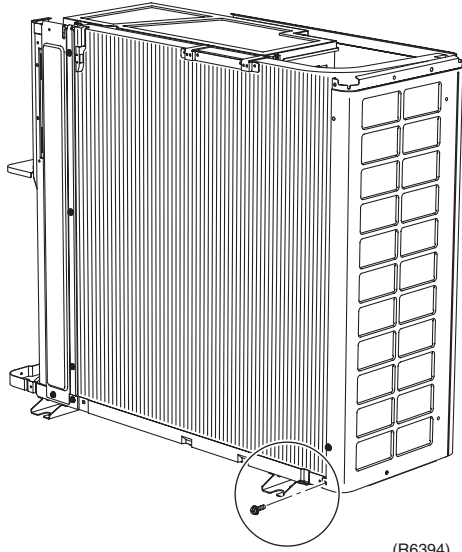

(R6394)

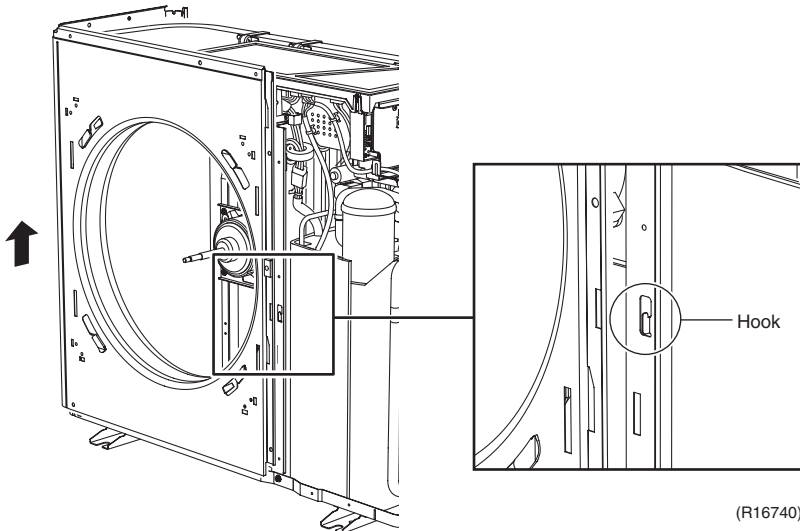

(R16740)

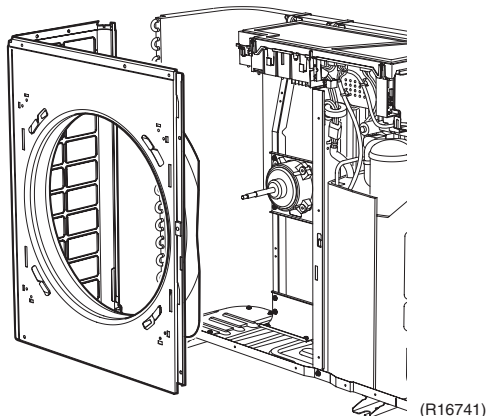

(R16741)

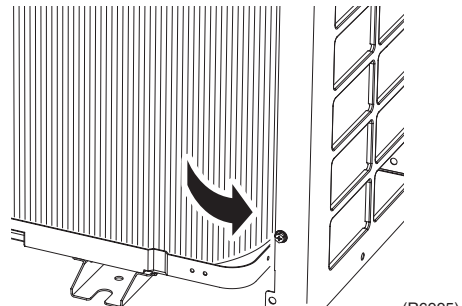

(R6995)

■ Be sure to detach the front panel (1) carefully so as not to deform it.

Step	Procedure	Points
7.	Remove the rear panel.	
1	Remove the screw on the partition plate (2).	
2	Slide the partition plate (2) to the left and remove it.	
3	Remove the 3 screws on the wire fixing plate.	
4	Remove the wire fixing plate and the insulation.	

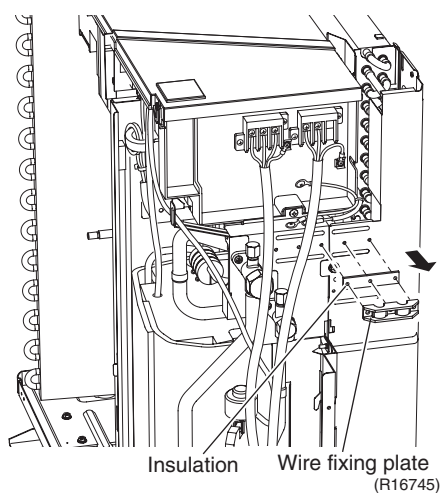
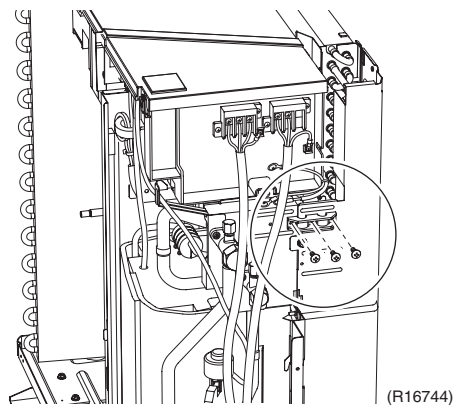
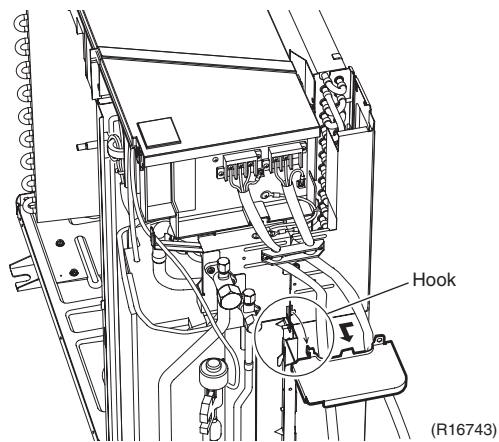
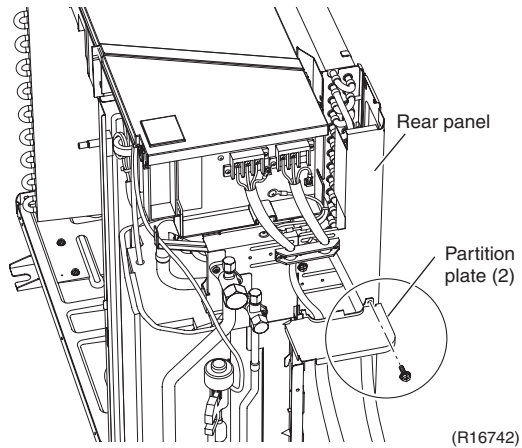

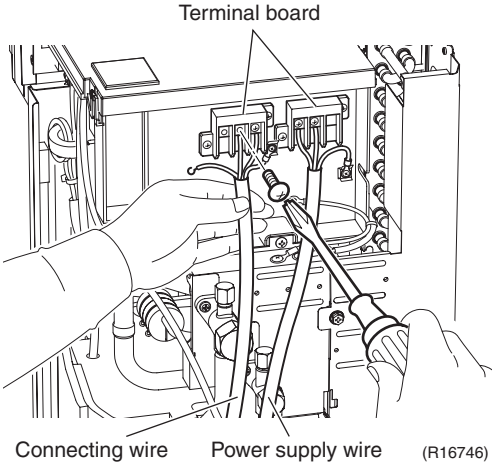
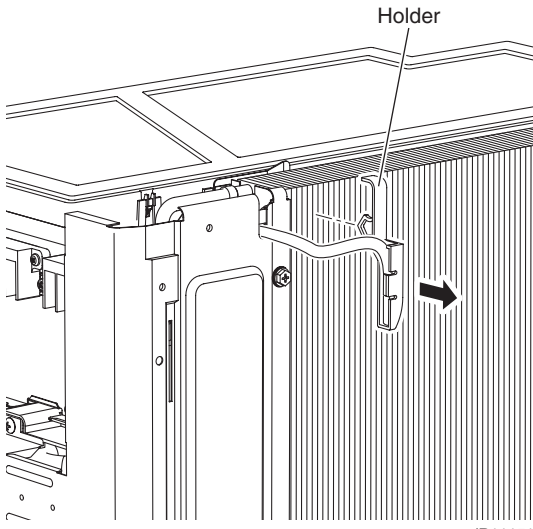
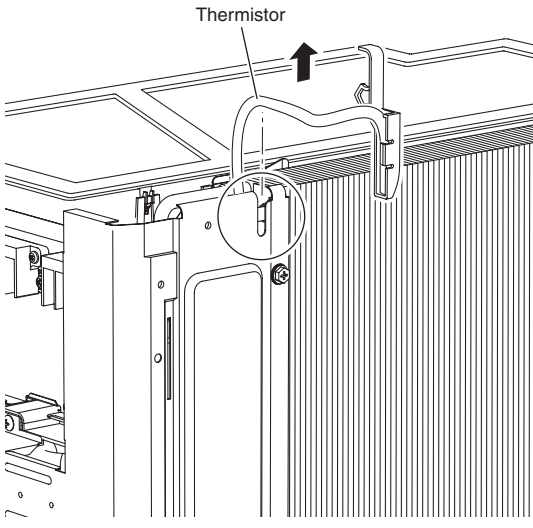
Step	Procedure	Procedure	Points
5	Remove the 7 screws of the terminal board and earth wires. Detach the connecting wire and the power supply wire.		
6	Release the holder of the outdoor temperature thermistor.		<ul style="list-style-type: none"> ■ The holder is secured in the clearances of the outdoor heat exchanger fins.
7	Release the harness of the outdoor temperature thermistor from the groove.		

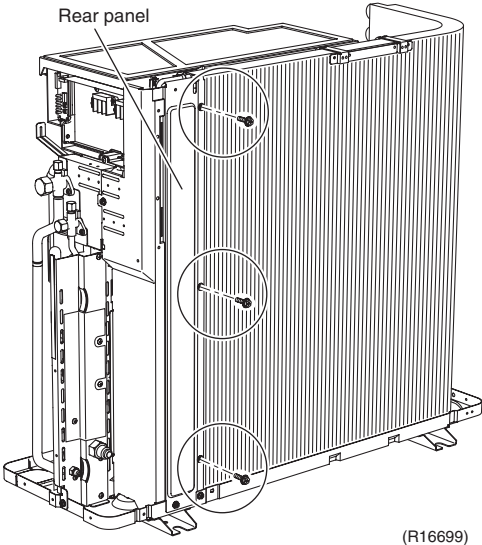
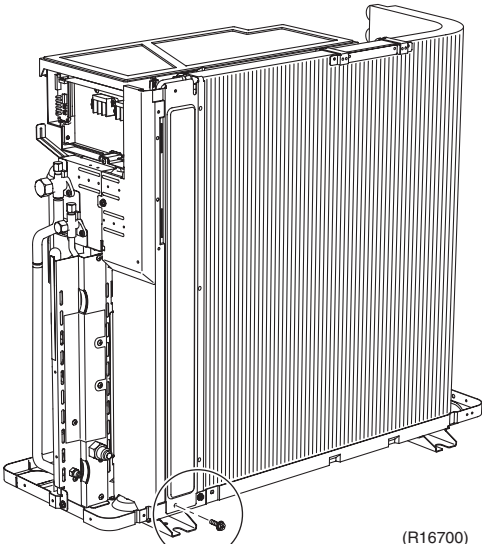
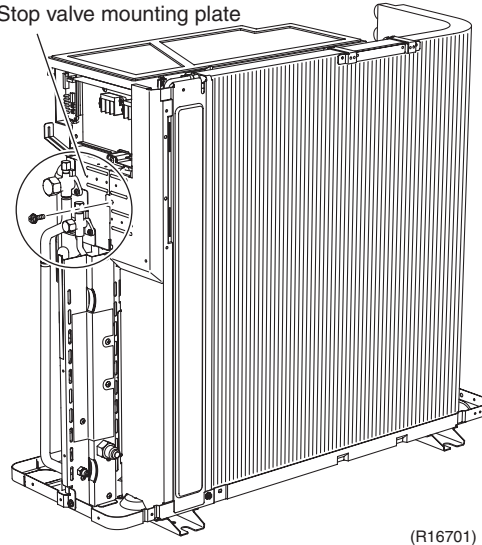
Step	Procedure	Points
8	Remove the 3 screws on the rear panel.	
	 <p>Rear panel</p> <p>(R16699)</p>	
9	Remove the screw on the bottom frame.	
	 <p>(R16700)</p>	
10	Remove the screw on the stop valve mounting plate.	
	 <p>Stop valve mounting plate</p> <p>(R16701)</p>	

Step	Procedure	Points
11	Lift the rear panel upward to unfasten the 2 hooks.	
12	Remove the rear panel.	

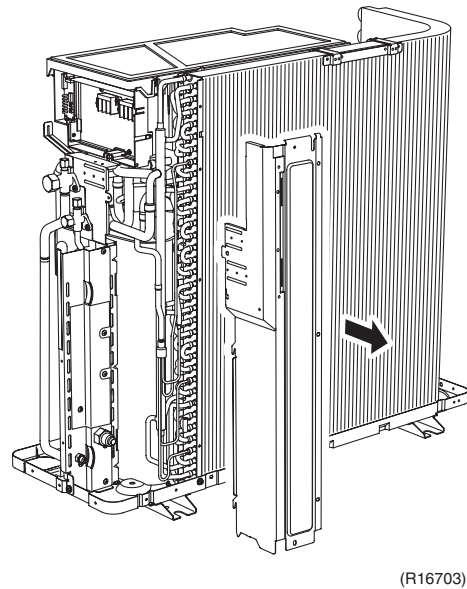
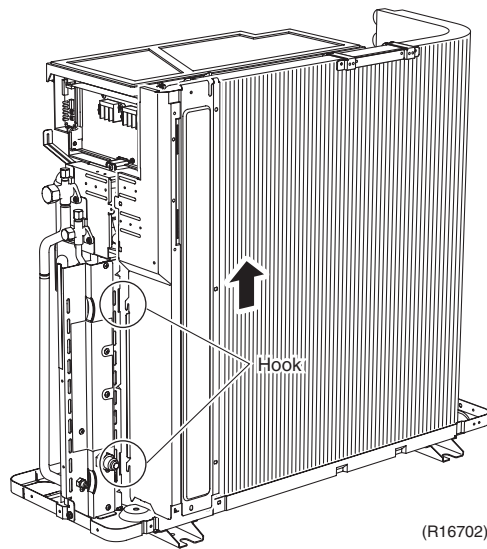

2. Removal of Electrical Box

Procedure



Warning Be sure to wait for 10 minutes or more after turning off all power supplies before disassembling work.

Step	Procedure	Points
1	Remove the screw on the stop valve mounting plate.	
2	Remove the screw on the partition plate (1).	
3	Remove the 2 screws to detach the earth wires.	

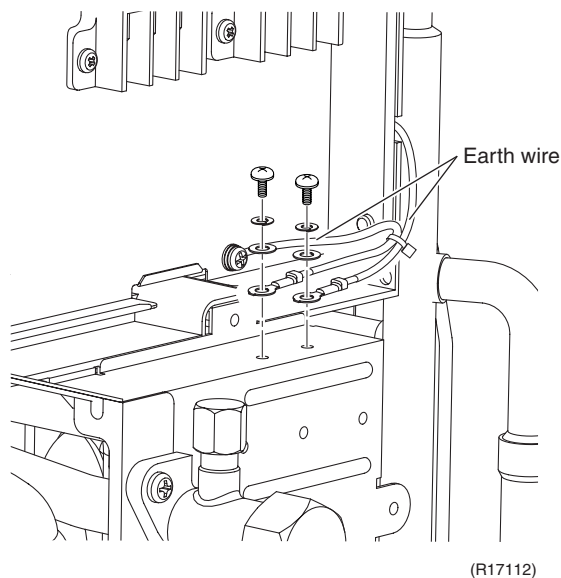
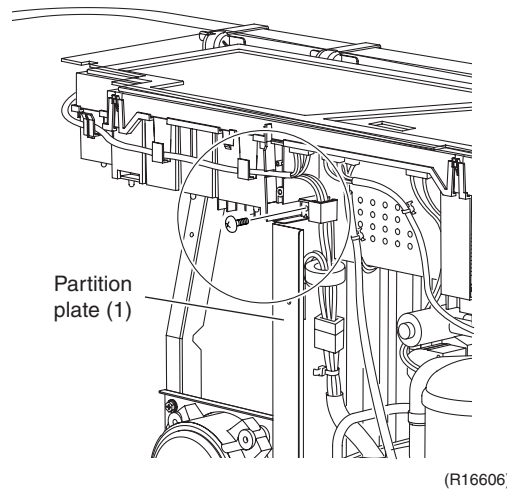
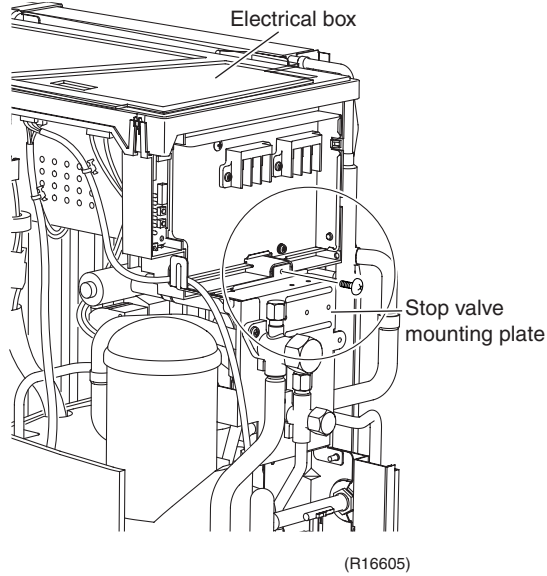

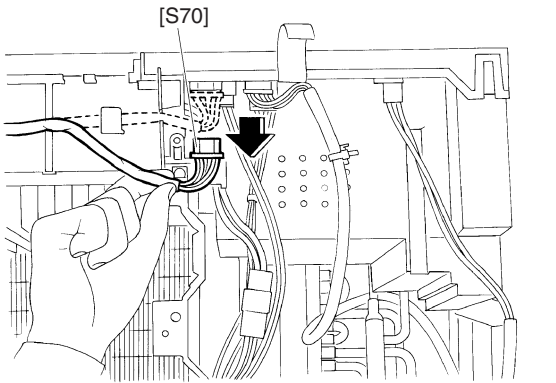
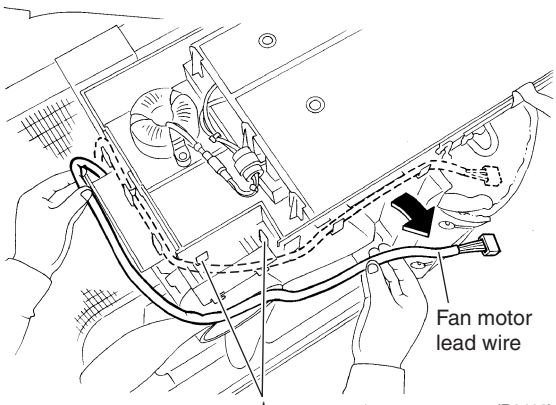
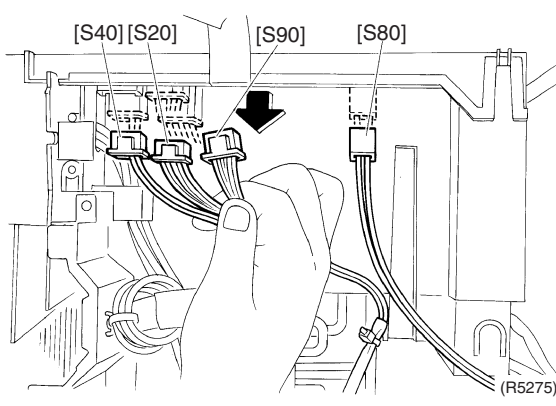
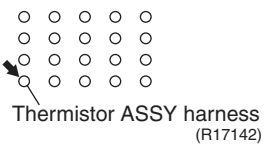
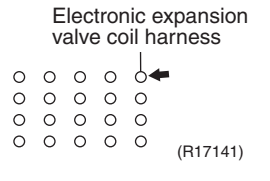
Step	Procedure	Points
4	Disconnect the connector for the fan motor [S70].	 <p>(R7008)</p>
5	Release the fan motor lead wire from the 5 hooks.	 <p>Fan motor lead wire</p> <p>(R9468)</p>
6	Disconnect the connectors of the front side.	 <p>(R5275)</p> <p>[S20]: electronic expansion valve coil [S40]: overload protector [S80]: four way valve coil [S90]: thermistors</p> <ul style="list-style-type: none"> ■ The cooling only models do not have the harness for [S80]. ■ When reassembling, insert the clamp of the thermistor ASSY harness into the hole as below.  <p>Thermistor ASSY harness (R17142)</p> <ul style="list-style-type: none"> ■ When reassembling, insert the clamp of the electronic expansion valve coil harness into the hole as below.  <p>Electronic expansion valve coil harness (R17141)</p>

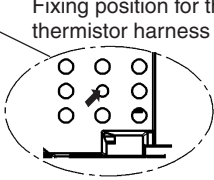
Step	Procedure	Points
7	Release the thermistor harness from the hook at the bottom of electrical box.	
8	Pull out the clamp of the thermistor harness from the hole of the electrical box.	<p>■ When reassembling, insert the clamp into the small hole.</p>  <p>Fixing position for the thermistor harness</p>
9	The compressor lead wire is fixed on the partition plate (1) with a clamp.	
10	Release the clamp of the compressor relay harness with pliers.	

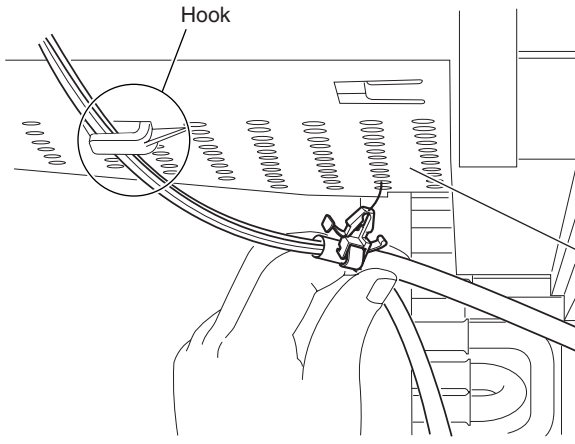

(R16647)

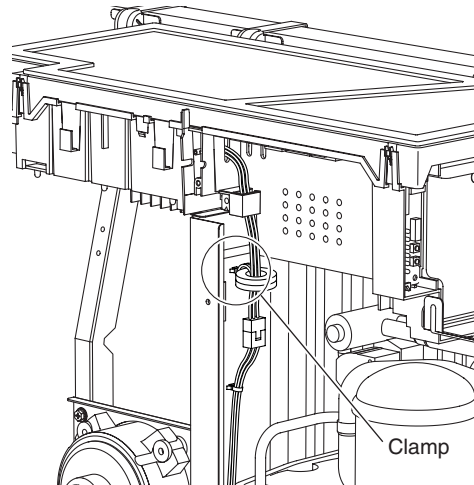

(R16704)

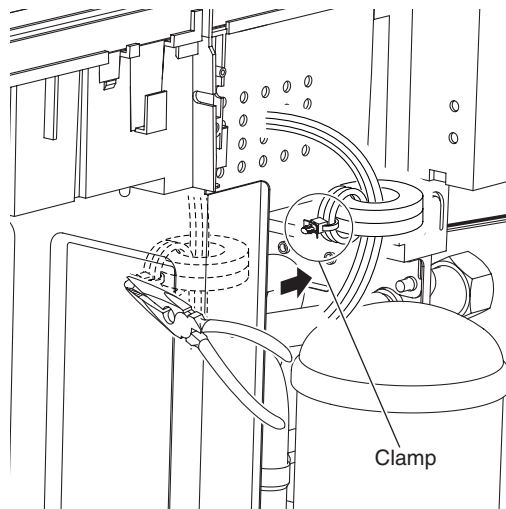

(R6423)

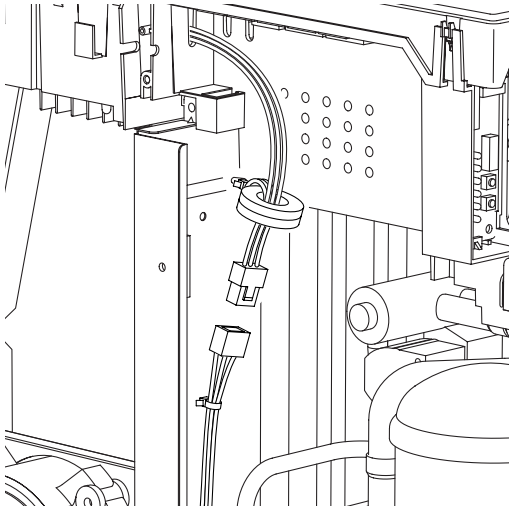
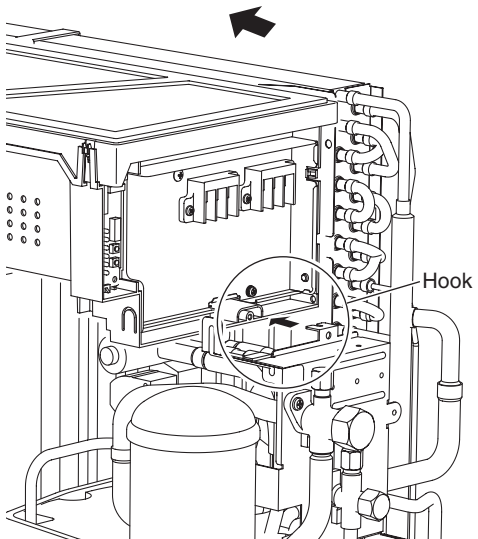
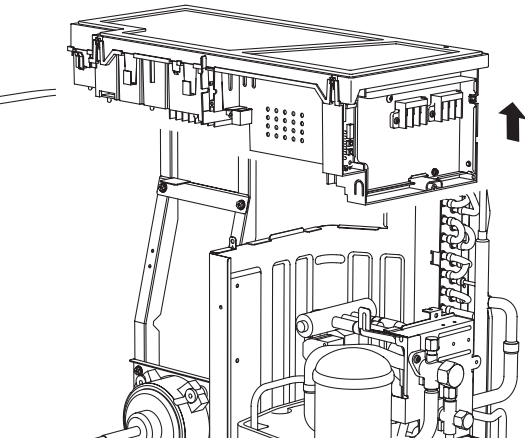
Step	Procedure	Points
11	<p>Disconnect the relay connector for the compressor.</p>  <p>(R6469)</p>	
12	<p>Slide the electrical box to the left to unfasten the hook on the right side of the box.</p>  <p>(R16705)</p>	
13	<p>Lift up the electrical box and remove it.</p>  <p>(R16706)</p>	

3. Removal of PCBs

Procedure



Warning

Be sure to wait for 10 minutes or more after turning off all power supplies before disassembling work.

Step	Procedure	Points
1	Disconnect the connectors [S52] [S102] from the service monitor PCB.	Preparation <ul style="list-style-type: none"> Remove the electrical box according to the "Removal of Electrical Box".
2	Detach the 4 clamps with pliers and remove the service monitor PCB.	
3	Remove the screws of the terminal board and the earth wire.	

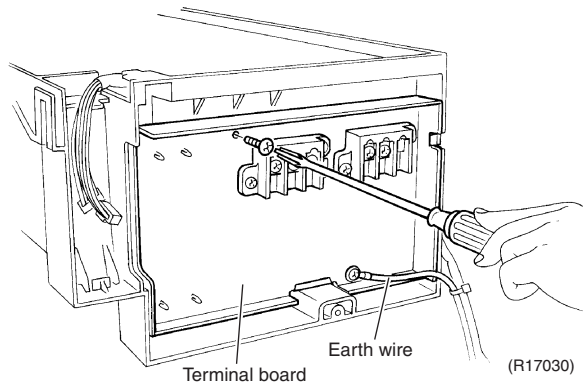
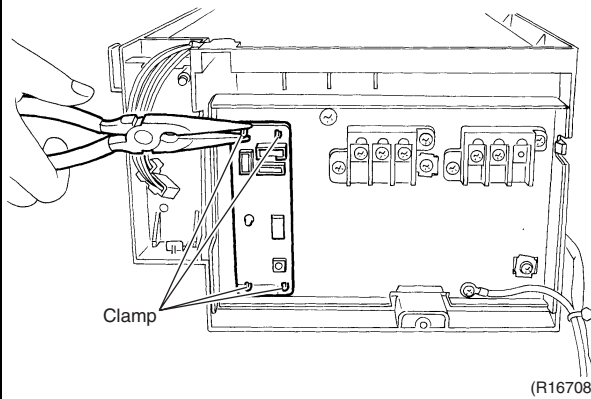
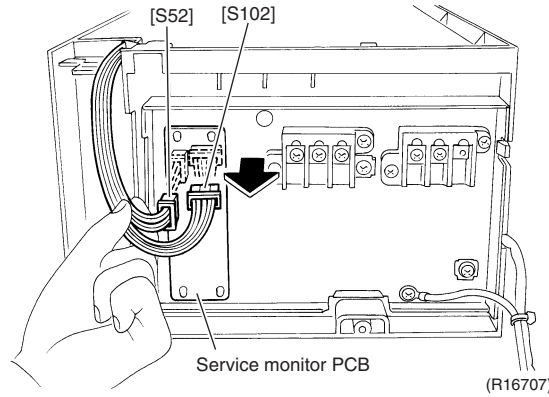

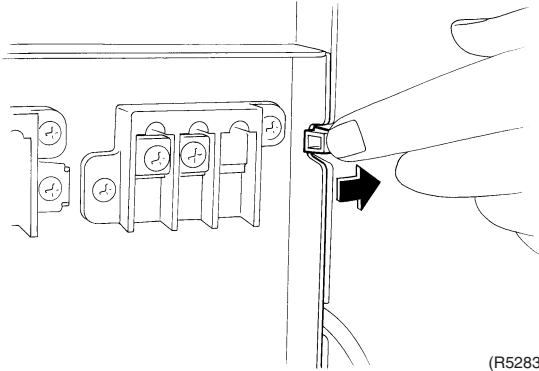
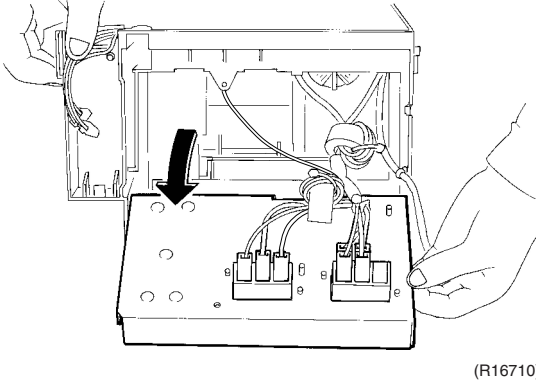
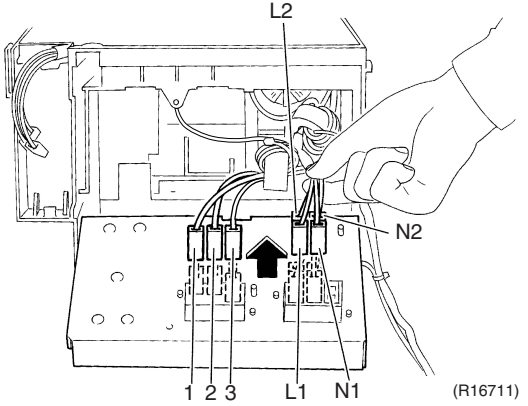
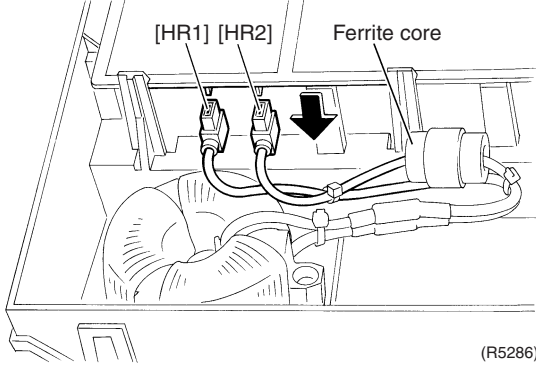
Step	Procedure	Points
4	Unfasten the hook on the right.	
	 <p>(R5283)</p>	
5	Open the terminal board.	
	 <p>(R16710)</p>	
6	Disconnect the harnesses.	
	 <p>(R16711)</p>	<p>1: Black 2: White 3: Red L1: Black L2: Brown N1: White N2: Blue</p>
7	Disconnect the 2 harnesses for the reactor [HR1] [HR2].	
	 <p>(R5286)</p>	<p>[HR1] : White [HR2] : Blue</p> <p>■ The harness for [HR2] has a ferrite core.</p>

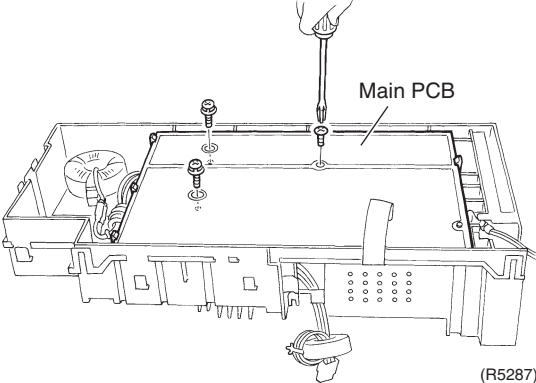
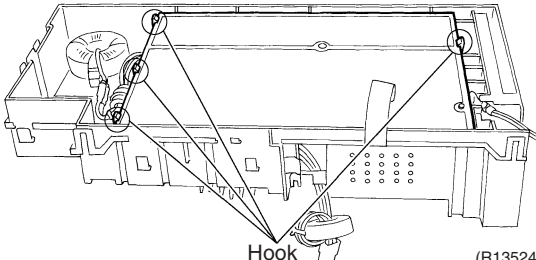
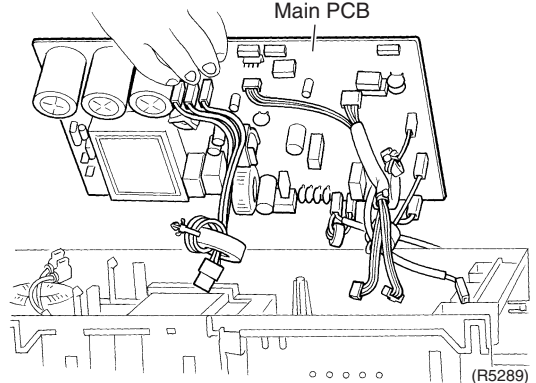
Step	Procedure	Points
8	<p>Remove the 3 screws of the main PCB.</p>  <p>(R5287)</p>	
9	<p>Release the 4 hooks.</p>  <p>Hook</p> <p>(R13524)</p>	
10	<p>Lift up and remove the main PCB.</p>  <p>Main PCB</p> <p>(R5289)</p>	

4. Removal of Fan Motor

Procedure



Warning

Be sure to wait for 10 minutes or more after turning off all power supplies before disassembling work.

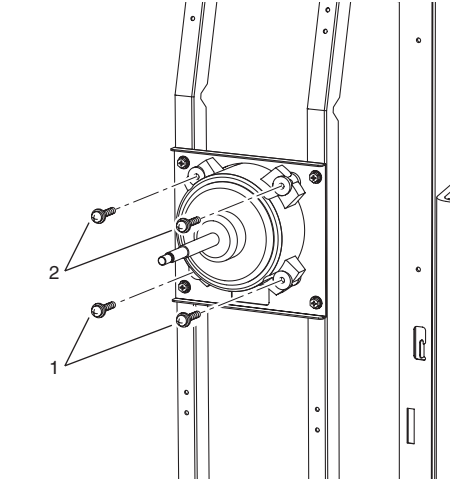
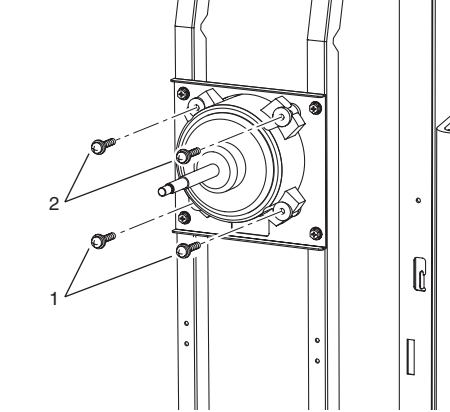
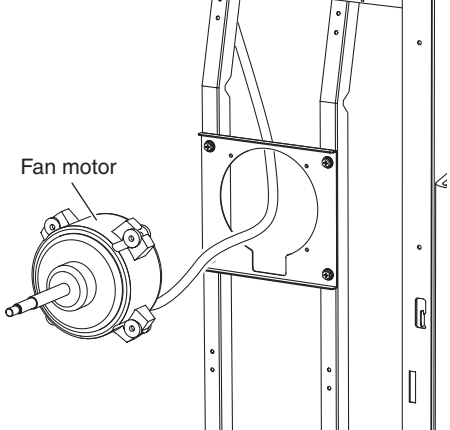
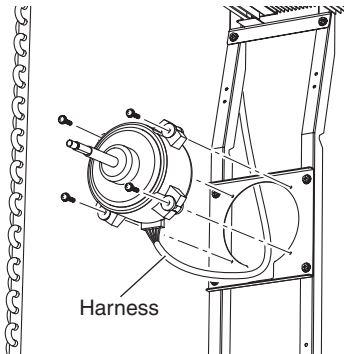
Step	Procedure	Procedure	Points
1	Remove the 2 lower screws first.	 <p style="text-align: right;">(R6442)</p>	<p>Preparation</p> <ul style="list-style-type: none"> ■ Remove the electrical box according to the "Removal of Electrical Box". ■ Be sure to remove the lower screws first. If the top screws are removed first, the fan motor may tilt down or fall and cause injury because its center of gravity is shifted to the front.
2	Then, remove the 2 upper screws.	 <p style="text-align: right;">(R6442)</p>	
3	Remove the fan motor.	 <p style="text-align: right;">(R6443)</p>	<ul style="list-style-type: none"> ■ When reassembling, make sure that the wire harness is facing downward.  <p style="text-align: right;">(R6444)</p>

5. Removal of Coils / Thermistors

Procedure



Warning Be sure to wait for 10 minutes or more after turning off all power supplies before disassembling work.

Step	Procedure	Points
<p>1. Remove the electronic expansion valve coil.</p> <p>1 Pull the electronic expansion valve coil out.</p>	<p>Electronic expansion valve coil</p> <p>(R11159)</p>	
<p>2. Remove the four way valve coil.</p> <p>1 Remove the screw.</p> <p>2 Remove the four way valve coil.</p>	<p>(R6457)</p> <p>Four way valve coil</p> <p>(R6458)</p>	<p>■ The cooling only models do not have a four way valve coil.</p>

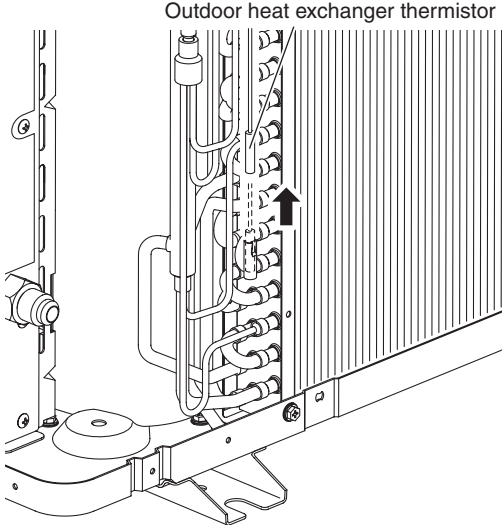
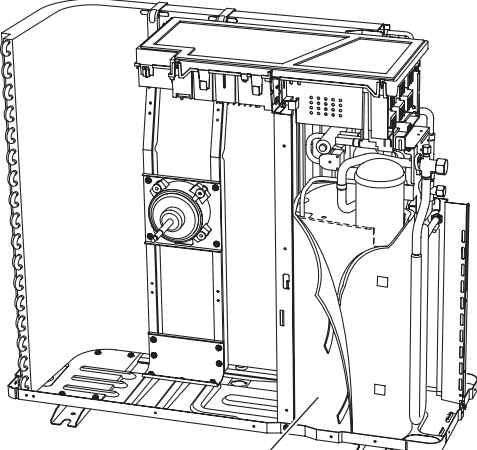
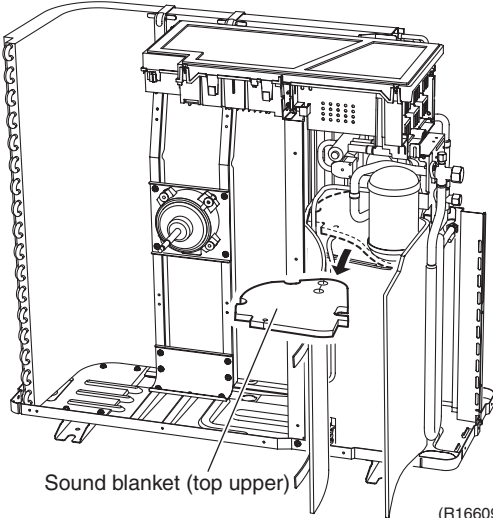
Step	Procedure	Points
<p>3. Remove the thermistors.</p>	<p>1 Pull out the outdoor heat exchanger thermistor.</p>  <p style="text-align: center;">Outdoor heat exchanger thermistor</p> <p style="text-align: right;">(R11160)</p> <p>2 Slightly open the sound blanket (outer).</p>  <p style="text-align: center;">Sound blanket (outer)</p> <p style="text-align: right;">(R7011)</p> <p>3 Remove the sound blanket (top upper).</p>  <p style="text-align: center;">Sound blanket (top upper)</p> <p style="text-align: right;">(R16609)</p>	

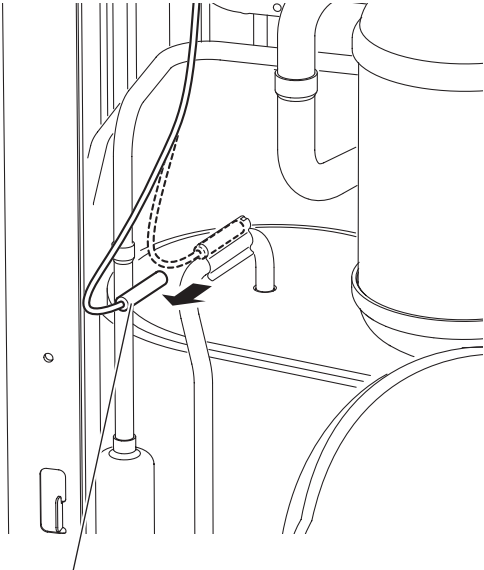
Step	Procedure	Points
4	<p data-bbox="199 219 459 280">Remove the discharge pipe thermistor.</p>  <p data-bbox="587 833 834 862">Discharge pipe thermistor</p> <p data-bbox="970 842 1027 864">(R9469)</p>	

6. Removal of Sound Blankets

Procedure



Warning Be sure to wait for 10 minutes or more after turning off all power supplies before disassembling work.

Step	Procedure	Points
1	Open the sound blanket (outer).	
2	Remove the sound blanket (top upper).	<ul style="list-style-type: none"> ■ The sound blanket is fragile. Carefully pass the discharge pipe through it.
3	Remove the screw and slightly push the partition plate (1) to the left for easy work.	

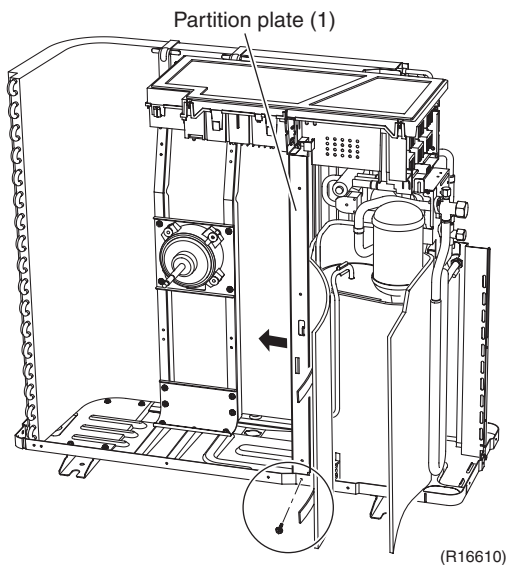
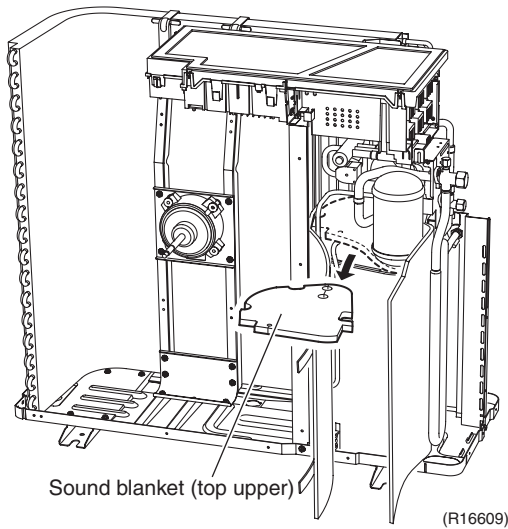
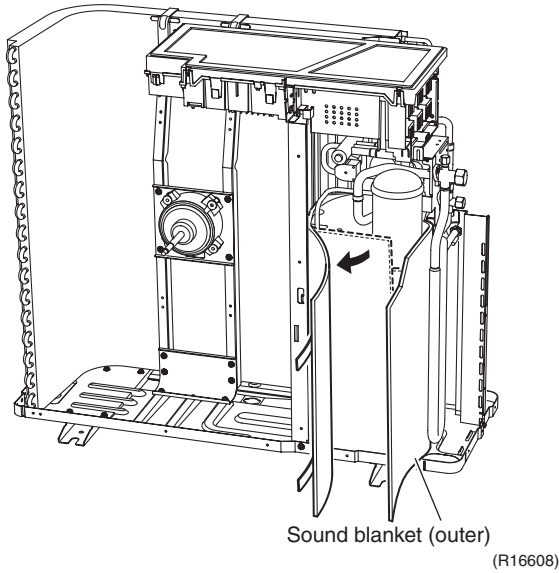

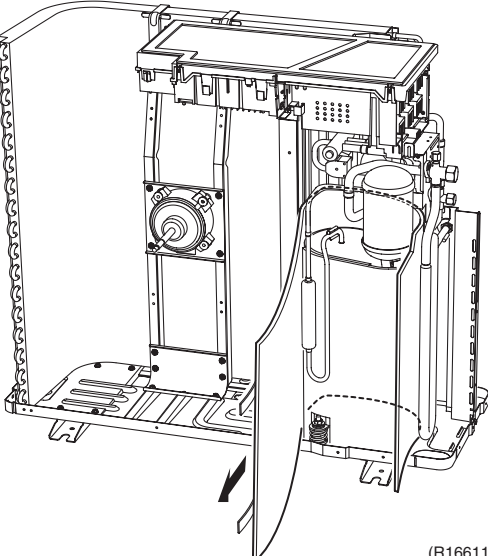
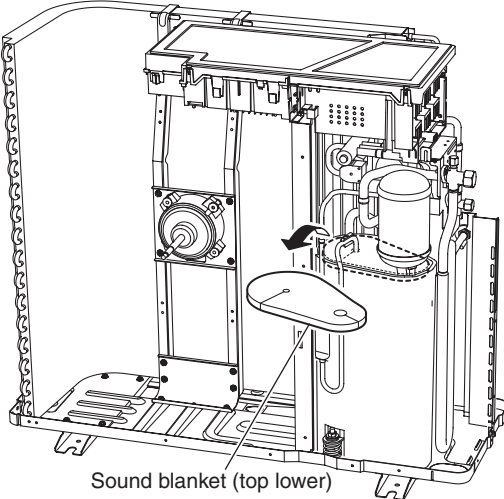
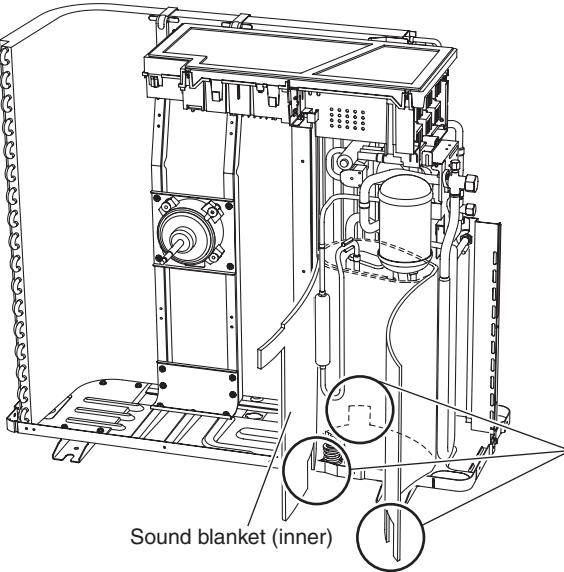
Step	Procedure	Procedure	Points
4	Remove the sound blanket (outer).	 <p>(R16611)</p>	
5	Remove the sound blanket (top lower).	 <p>Sound blanket (top lower)</p> <p>(R16612)</p>	<ul style="list-style-type: none"> ■ The sound blanket is fragile. Carefully pass the discharge pipe through it.
6	Open the sound blanket (inner).	 <p>Sound blanket (inner)</p> <p>(R7018)</p>	<ul style="list-style-type: none"> ■ The sound blanket is fragile. Be careful of the notches of the compressor mount (3 locations).

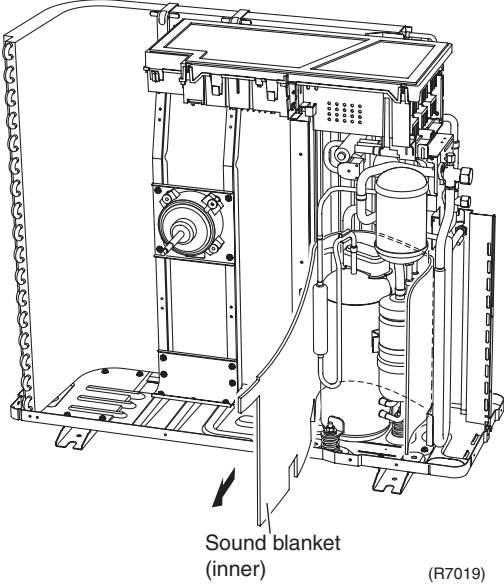
Step	Procedure	Points
<p>7</p>	<p>Remove the sound blanket (inner).</p>  <p>Sound blanket (inner) (R7019)</p>	

7. Removal of Compressor

Procedure

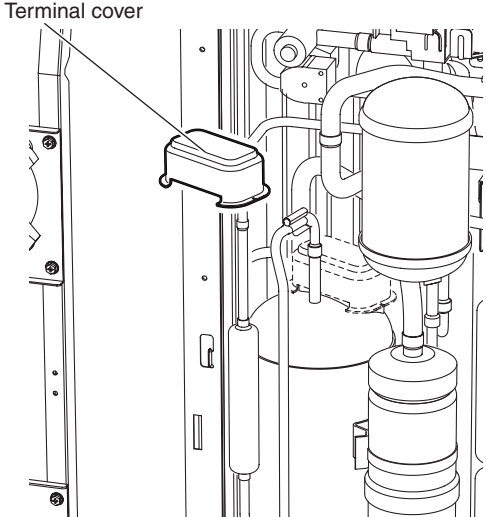
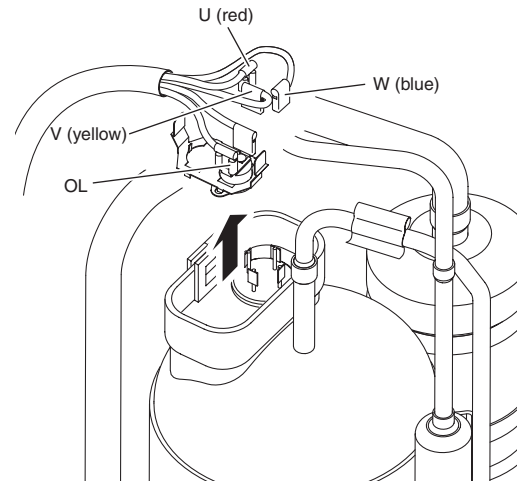

Warning Be sure to wait for 10 minutes or more after turning off all power supplies before disassembling work.

Step	Procedure	Points
1	<p>Remove the terminal cover.</p>  <p style="text-align: right;">(R9690)</p>	
2	<p>Pull out the 3 lead wires.</p>	
3	<p>Remove the overload protector (OL).</p>  <p style="text-align: right;">(R9471)</p>	

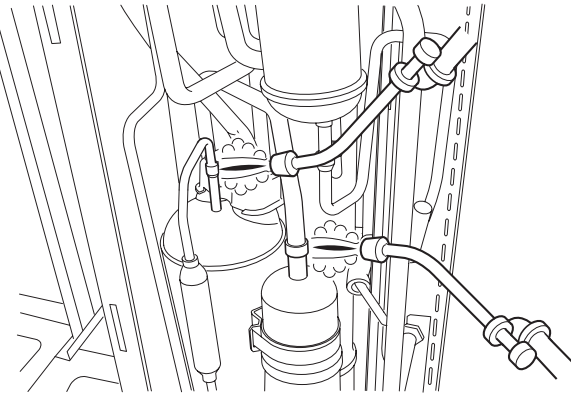
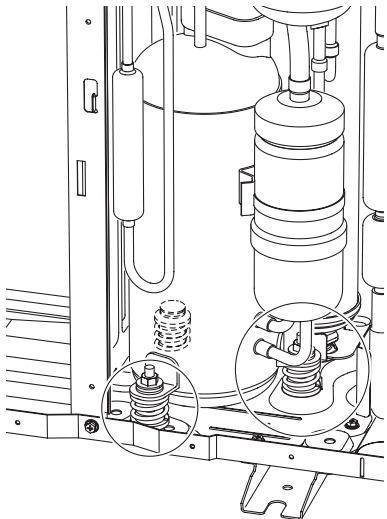
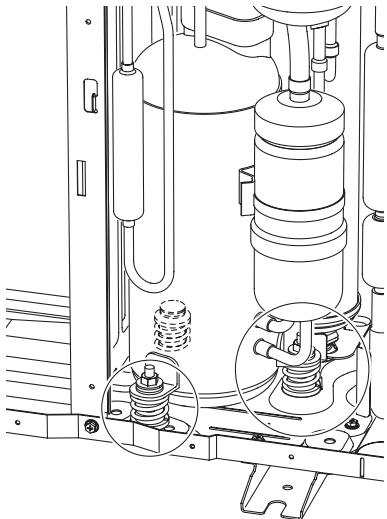
Step	Procedure	Points
<ul style="list-style-type: none"> ■ Before working, make sure that the refrigerant gas is empty in the circuit. ■ Be sure to apply nitrogen replacement when heating up the brazed part. 	 <p style="text-align: right;">(R9646)</p>	<p>Warning Be careful not to get yourself burnt with the pipes and other parts that are heated by the gas brazing machine.</p>
<p>4 Heat up the brazed part and withdraw the piping with pliers.</p>	 <p style="text-align: right;">(R9472)</p>	<p>Warning If the refrigerant gas leaks during work, ventilate the room. (If the refrigerant gas is exposed to flames, toxic gas may be generated.)</p>
<p>5 Remove the 2 nuts.</p>	 <p style="text-align: right;">(R9472)</p>	<p>Warning Since it may happen that the refrigerant oil in the compressor catches fire, prepare wet cloth so as to extinguish fire immediately.</p> <p>Caution From the viewpoint of global environment protection, do not discharge the refrigerant gas in the atmosphere. Make sure to collect all the refrigerant gas.</p> <p>Cautions for restoration</p> <ol style="list-style-type: none"> 1. Restore the piping by non-oxidation brazing. 2. It is required to prevent the carbonization of the oil inside the four way valve and the deterioration of the gaskets affected by heat. (Keep below 120°C.) For the sake of this, wrap the four way valve with wet cloth and provide water so that the cloth does not dry.
<p>Note:</p> <ul style="list-style-type: none"> ■ Do not use a metal saw for cutting pipes by all means because the sawdust comes into the circuit. ■ When withdrawing the pipes, be careful not to pinch them firmly with pliers. The pipes may get deformed. ■ Provide a protective sheet or a steel plate so that the brazing flame cannot influence peripheries. ■ Be careful so as not to burn the compressor terminals, the name plate, the heat exchanger fin. 		<p>In case of difficulty with gas brazing machine</p> <ol style="list-style-type: none"> 1. Disconnect the brazed part where is easy to disconnect and restore. 2. Cut pipes on the main unit with a tube cutter in order to make it easy to disconnect.

Revision History

Month / Year	Version	Revised contents
06 / 2013	Si00-877	First edition

Warning



- Daikin products are manufactured for export to numerous countries throughout the world. Prior to purchase, please confirm with your local authorised importer, distributor and/or retailer whether this product conforms to the applicable standards, and is suitable for use, in the region where the product will be used. This statement does not purport to exclude, restrict or modify the application of any local legislation.
- Ask a qualified installer or contractor to install this product. Do not try to install the product yourself. Improper installation can result in water or refrigerant leakage, electrical shock, fire or explosion.
- Use only those parts and accessories supplied or specified by Daikin. Ask a qualified installer or contractor to install those parts and accessories. Use of unauthorised parts and accessories or improper installation of parts and accessories can result in water or refrigerant leakage, electrical shock, fire or explosion.
- Read the User's Manual carefully before using this product. The User's Manual provides important safety instructions and warnings. Be sure to follow these instructions and warnings.

If you have any enquiries, please contact your local importer, distributor and/or retailer.

Cautions on product corrosion

1. Air conditioners should not be installed in areas where corrosive gases, such as acid gas or alkaline gas, are produced.
2. If the outdoor unit is to be installed close to the sea shore, direct exposure to the sea breeze should be avoided. If you need to install the outdoor unit close to the sea shore, contact your local distributor.

Dealer

DAIKIN INDUSTRIES, LTD.

Head Office:
Umeda Center Bldg., 2-4-12, Nakazaki-Nishi,
Kita-ku, Osaka, 530-8323 Japan

Tokyo Office:
JR Shinagawa East Bldg., 2-18-1, Konan,
Minato-ku, Tokyo, 108-0075 Japan

http://www.daikin.com/global_ac/

©All rights reserved