

# REMOVAL PROCEDURE



SERVICE  
MANUAL

S E R V I C E M A N U A L

## 2.5/3.2 kW Class

-  Outdoor Unit
-  Inverter
-  Pair Type



# **Service Manual Removal Procedure**

## **Outdoor Unit**

### **●Heat Pump**

**RX25FV2C**

**RX32FV2C**

# Table of Contents

1. Removal of Panels .....	2
2. Removal of Fan Motor / Propeller Fan .....	4
3. Removal of PCB.....	5
4. Removal of Sound Blanket.....	12
5. Removal of Four Way Valve .....	14
6. Removal of Compressor .....	17



**Note:** ♦ The illustrations may be slightly different depending on the model.

# 1. Removal of Panels

**Procedure**

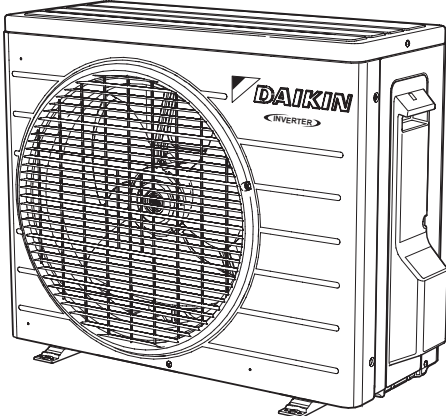
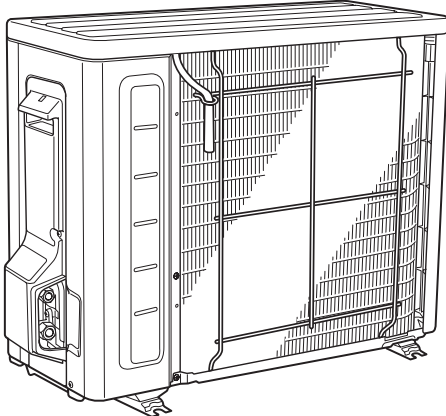
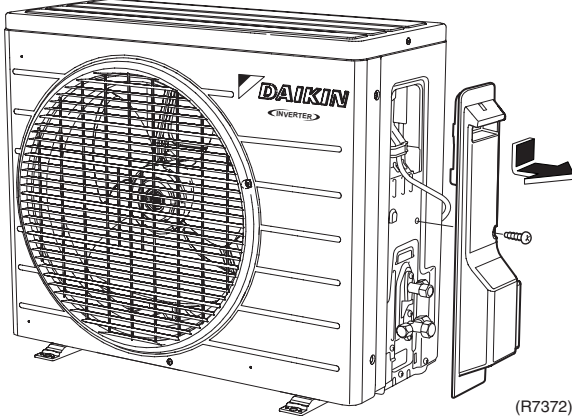
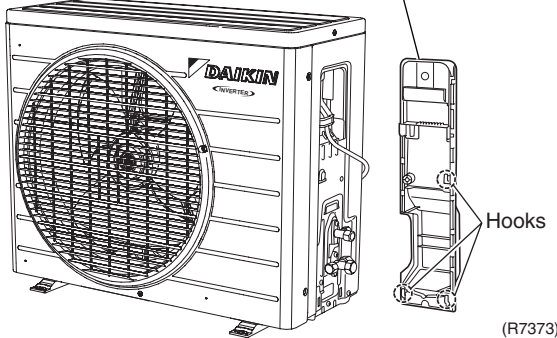

**Warning** Be sure to wait 10 minutes or more after turning off all power supplies before disassembling work.

Step	Procedure	Points
1. Features	 <p>(R7370)</p>  <p>(R7371)</p>  <p>(R7372)</p>  <p>(R7373)</p>	<ul style="list-style-type: none"> <li>■ Take care not to cut your finger by the fins of the heat exchanger.</li>   <li>■ The stop valve cover is united with the shelter.</li> <li>■ When reassembling, make sure to fit the 3 hooks.</li> </ul>
1	<p>Loosen the screw of the stop valve cover. Pull down the stop valve cover and remove it.</p>	

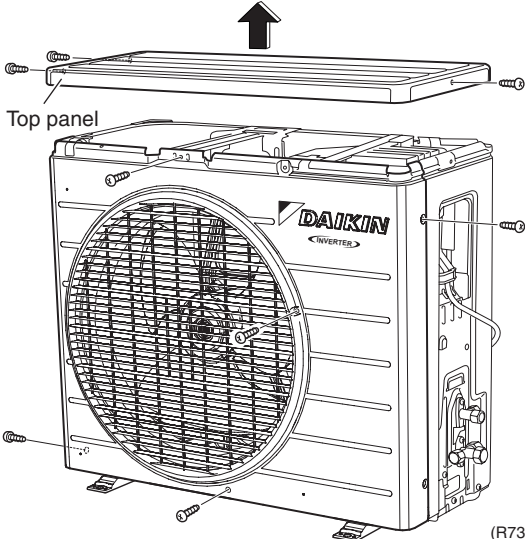
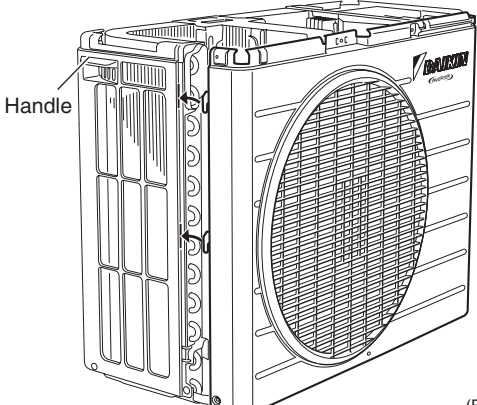
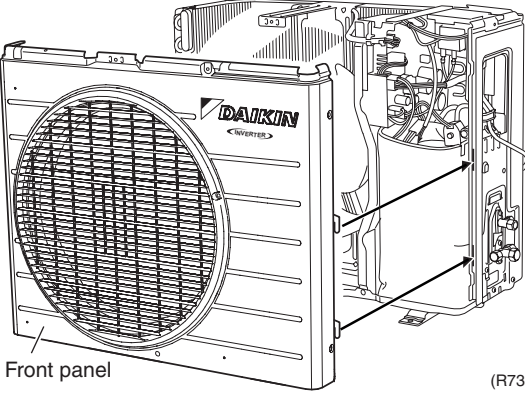
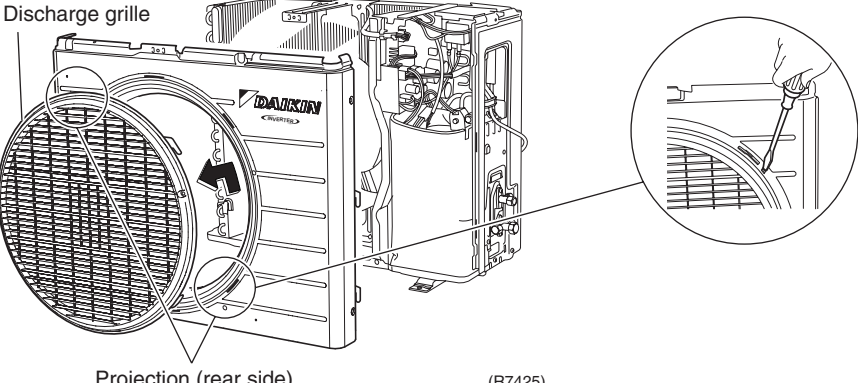
Step	Procedure	Points
2. Remove the panels.		
1	<p>Loosen the 3 screws (right: 2 screws, left: 1 screw) and lift the top panel from the rear side at first.</p>	
2	<p>Loosen the 5 screws of the front panel.</p>	 <p>Top panel</p> <p>(R7374)</p>
3	<p>Lift up the left side and undo the hook.</p>	 <p>Handle</p> <p>(R7375)</p>
4	<p>Undo the right side hook and remove the front panel.</p>	 <p>Front panel</p> <p>(R7376)</p>
5	<p>Undo the 6 hooks and remove the discharge grille.</p>	 <p>Discharge grille</p> <p>Projection (rear side)</p> <p>(R7425)</p>
6	<p>The discharge grille has 2 projections to prevent its rotation. Press the projection from the rear side and remove it clockwise.</p>	

## 2. Removal of Fan Motor / Propeller Fan

**Procedure**

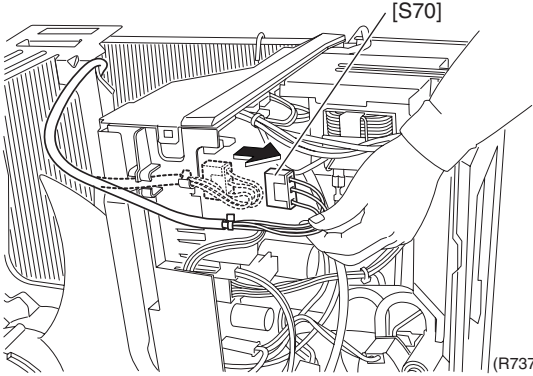
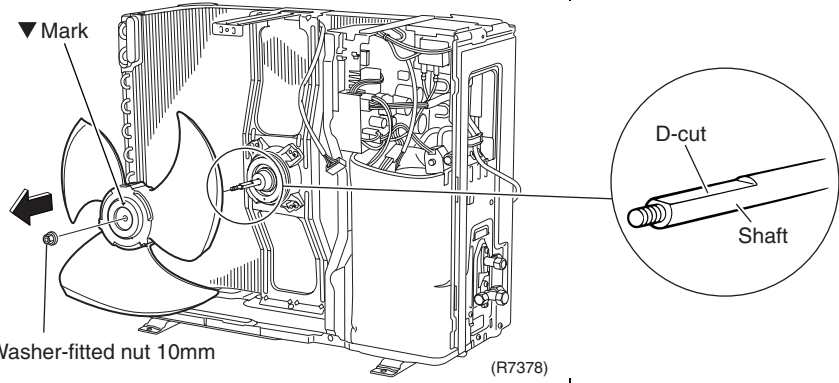
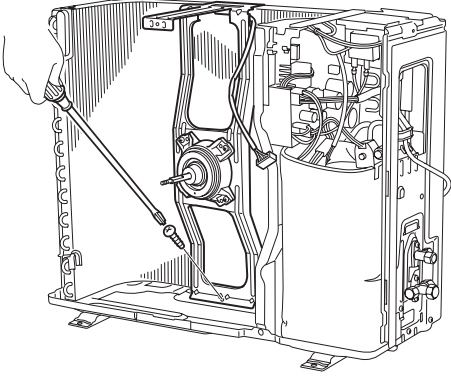
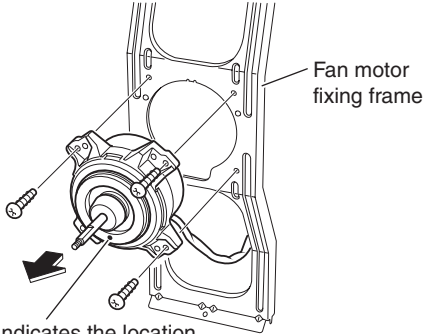
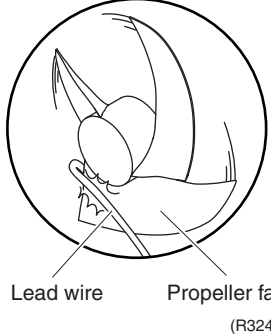
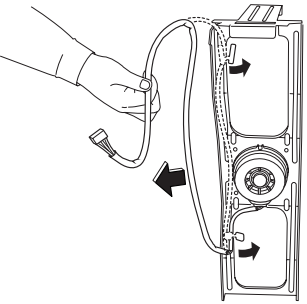

**Warning** Be sure to wait 10 minutes or more after turning off all power supplies before disassembling work.

Step	Procedure	Points
<p>■ Remove the panels.</p> <p>1. Remove the propeller fan.</p> <p>1 Disconnect the fan motor connector (S70).</p> <p>2 Loosen the fixing hooks and release the lead wire.</p> <p>3 Unscrew the washer-fitted nut (M10) of the propeller fan with a spanner.</p> <p>4 Remove the propeller fan.</p>	 <p>[S70]</p> <p>(R7377)</p>  <p>▼ Mark</p> <p>Washer-fitted nut 10mm</p> <p>D-cut</p> <p>Shaft</p> <p>(R7378)</p>	<p>■ Align the ▼ mark of the propeller fan with the D-cut section of the motor shaft when reassembling.</p>
<p>2. Remove the fan motor.</p> <p>1 Loosen the screw to remove the fan motor fixing frame.</p> <p>2 Loosen the fixing hooks and release the lead wire.</p> <p>3 Loosen the 3 screws to remove the fan motor.</p>	 <p>(R7379)</p>  <p>Fan motor fixing frame</p> <p>● Mark indicates the location of the lead wire.</p> <p>(R7380)</p>	<p>■ Put the lead wire through the back of the motor when reassembling. (so as not to be entangled with the propeller fan)</p>  <p>Lead wire</p> <p>Propeller fan</p> <p>(R3249)</p>  <p>(R7381)</p>

### 3. Removal of PCB

#### Procedure

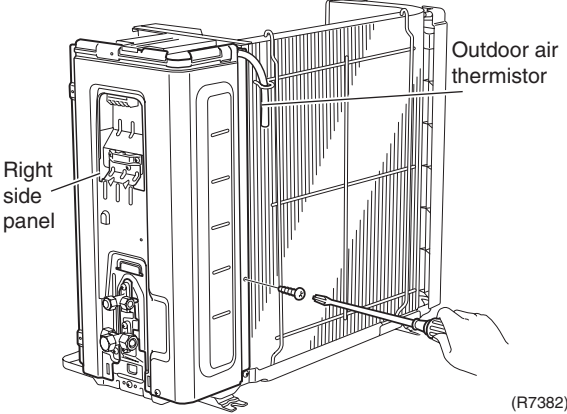
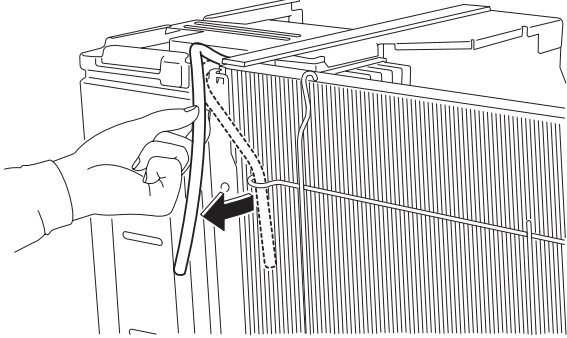
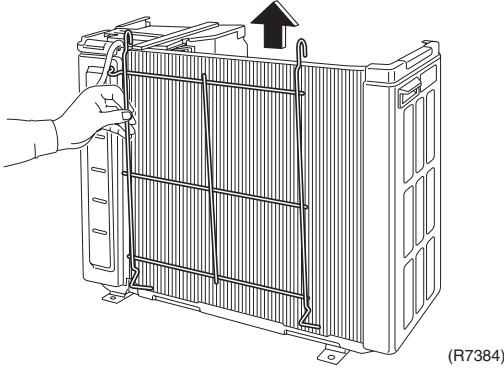
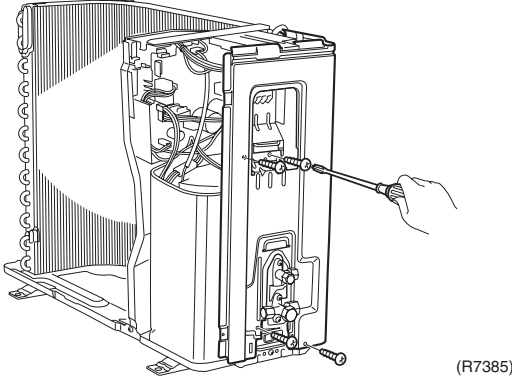

**Warning** Be sure to wait 10 minutes or more after turning off all power supplies before disassembling work.

Step	Procedure	Points
<p>■ Remove the panels.</p>	 <p>(R7382)</p>  <p>(R7383)</p>  <p>(R7384)</p>  <p>(R7385)</p>	<p>■ The outdoor air thermistor is hooked on the guard net.</p>
<p>1. Remove the right side panel.</p>		
<p>1 Loosen the screw on the rear side.</p>		
<p>2 Unhook the outdoor air thermistor.</p>		
<p>3 Lift up the guard net to remove.</p>		
<p>4 Loosen the 4 screws on the right side.</p>		

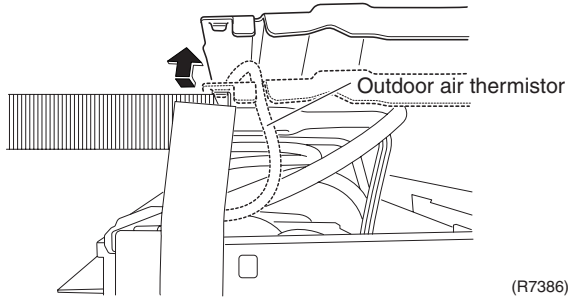
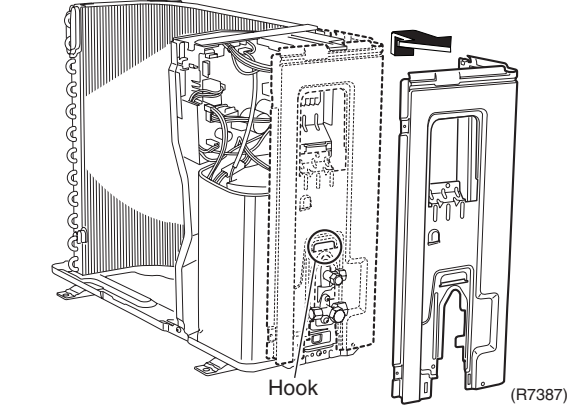
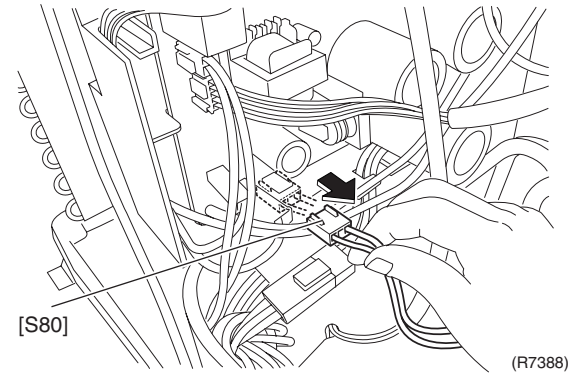
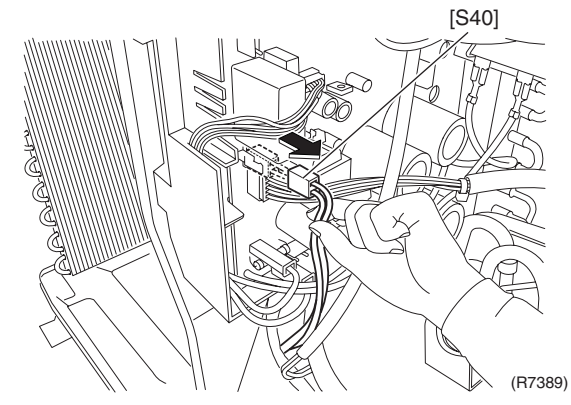
Step	Procedure	Points
5	Undo the rear side hook.	<ul style="list-style-type: none"> <li>When reassembling, make sure to fit the hook.</li> </ul>
6	Lift up the right side panel to remove.	
 <p style="text-align: right;">(R7386)</p>		
 <p style="text-align: right;">(R7387)</p>		
2. Remove the electrical box.		
1	Disconnect the connector for four way valve coil (S80).	
 <p style="text-align: right;">(R7388)</p>		
2	Disconnect the connector for overload protector.	
 <p style="text-align: right;">(R7389)</p>		

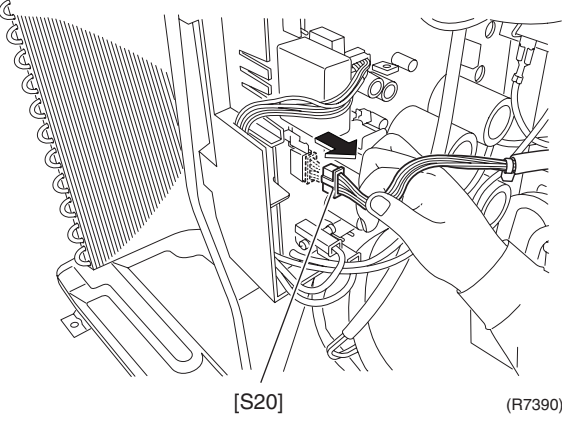
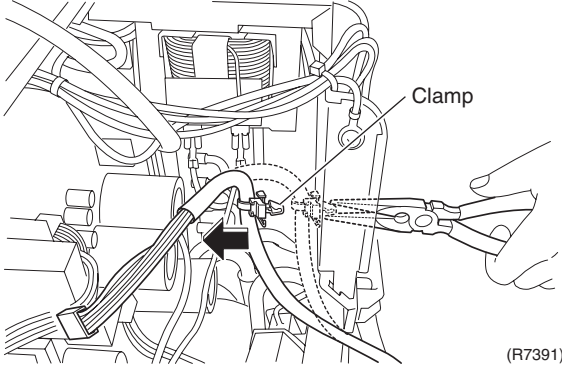
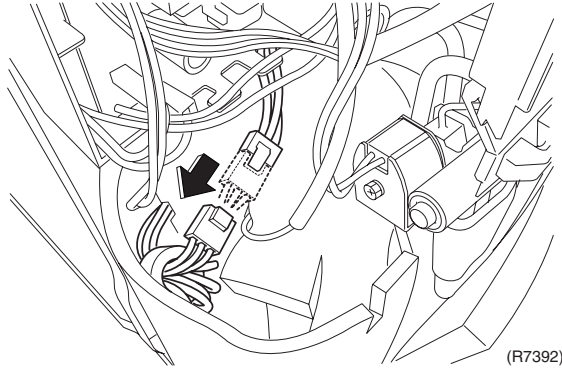
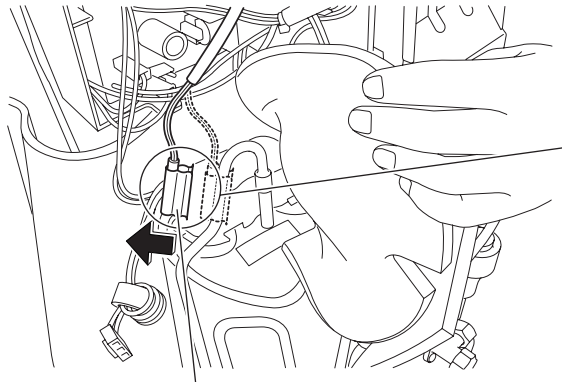
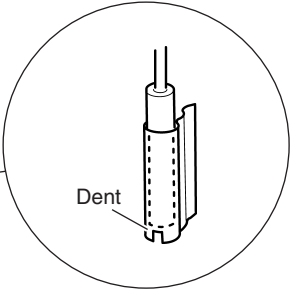

Step	Procedure	Points
3	<p>Disconnect the connector for electronic expansion valve coil.</p> 	
4	<p>Detach the clamp.</p> 	
5	<p>Disconnect the connector for compressor motor.</p> 	<ul style="list-style-type: none"> <li>■ Pay attention so as not to lose the clip for thermistor.</li> <li>■ When reassembling, do not cover the dent of clip by inserting the thermistor.</li> </ul>
6	<p>Release the discharge pipe thermistor.</p>  <p style="text-align: center;">Discharge pipe thermistor</p>	 <p style="text-align: center;">Dent</p>

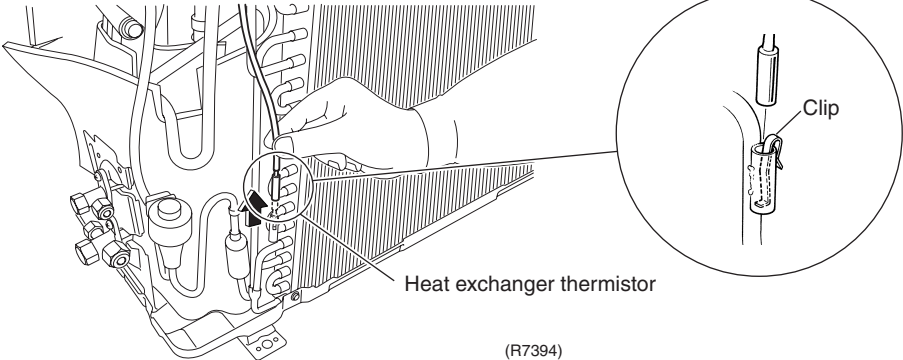
Step	Procedure	Points
7	Release the heat exchanger thermistor.	 <p>Heat exchanger thermistor</p> <p>Clip</p>
8	Cut the clamp.	<ul style="list-style-type: none"> <li>■ Pay attention so as not to lose the clip.</li> </ul>
9	Undo the hook from the partition plate.	<ul style="list-style-type: none"> <li>■ The electrical box can be removed by lifting itself without a screw driver.</li> </ul>
10	Lift and remove the electrical box.	

Step	Procedure	Points
3. Remove the PCB.		The lead-free solder (PbF) is used on PCB. When exchange, use exclusive solder and soldering gun.
1	Loosen the screw on the terminal board.	
2	Cut the clamp.	
3	Loosen the 2 screws of the earth terminal.	
4	Disconnect the 2 connectors of the reactor.	
	<p>Terminal board (R7397)</p> <p>(R7398)</p> <p>(R7399)</p> <p>Reactor (R7400)</p> <p>Brown White</p>	

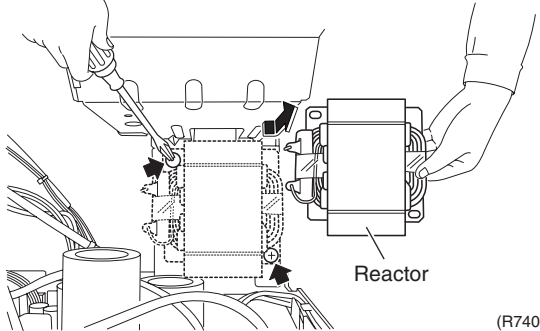
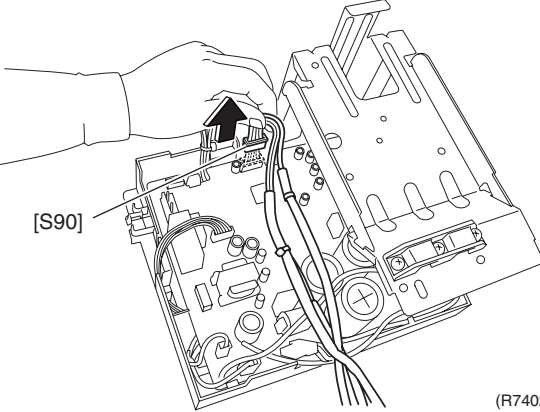
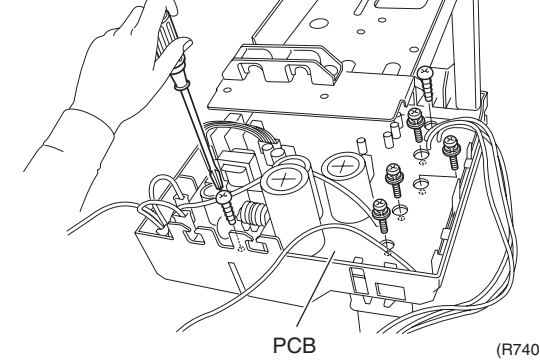
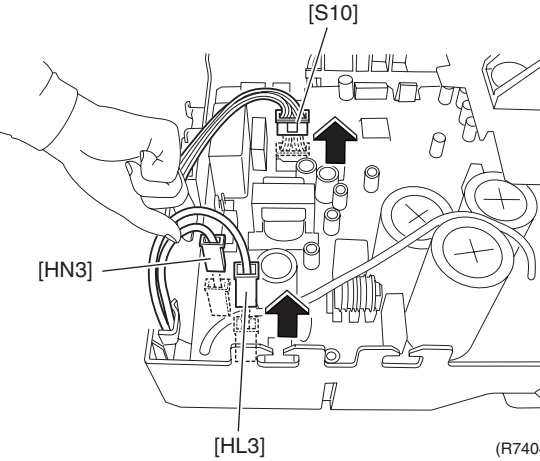
Step	Procedure	Points
5	Loosen the 2 screws to remove the reactor.	
	 <p>(R7401)</p>	
6	Disconnect the connector for thermistor (S90).	
	 <p>(R7402)</p>	
7	Loosen the 6 screws.	
	 <p>PCB (R7403)</p>	
8	Disconnect the 3 connectors for filter PCB (S10, HN3, HL3).	
	 <p>(R7404)</p>	

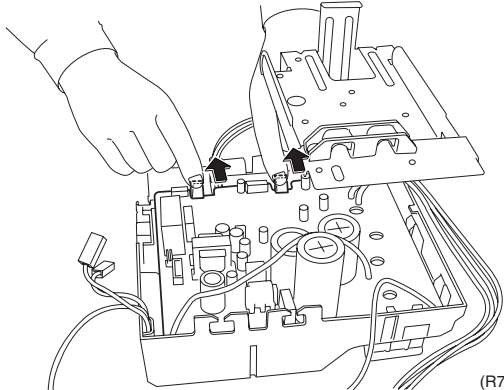
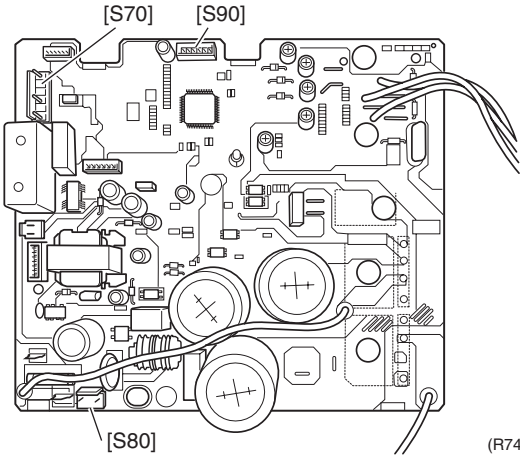
Step	Procedure	Points
9 Undo the 2 hooks. 10 Lift and Remove the PCB.	 <p>(R7405)</p>	
11 Feature of the PCB. [S70]: fan motor [S80]: four way valve [S90]: thermistor	 <p>(R7406)</p>	

# 4. Removal of Sound Blanket

**Procedure**



**Warning** Be sure to wait 10 minutes or more after turning off all power supplies before disassembling work.

Step	Procedure	Points
1. Remove the partition plate.	<p>(R7407)</p>	
<p>1 Loosen the 2 screws.</p> <p>2 The partition plate has a hook on the lower side. Lift and pull the partition plate to remove.</p>	<p>(R7408)</p>	<ul style="list-style-type: none"> <li>■ When reassembling, fit the lower hook into the bottom frame.</li> </ul>
2. Remove the sound blanket.	<p>(R7409)</p>	<ul style="list-style-type: none"> <li>■ Since the piping ports on the sound blanket are torn easily, remove the blanket carefully.</li> </ul>

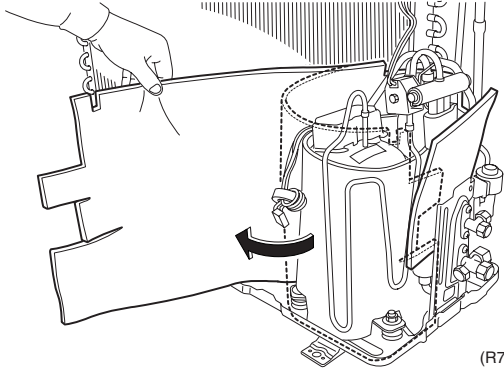
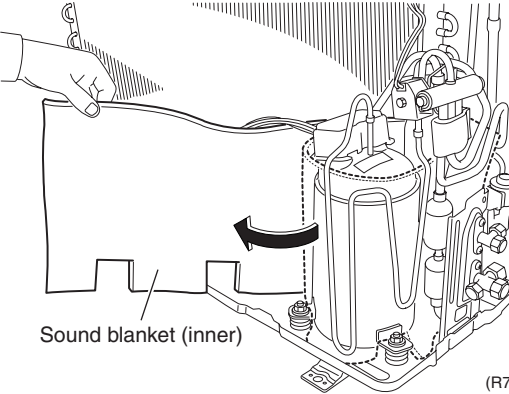
Step	Procedure	Points
2	Lift and remove the sound blanket (body) as it is opened.	(R7410)
3	Pull the sound blanket (inner) out.	<ul style="list-style-type: none"> <li>■ Since the piping ports on the sound blanket are torn easily, remove the blanket carefully.</li> </ul>
		
		

# 5. Removal of Four Way Valve

**Procedure**

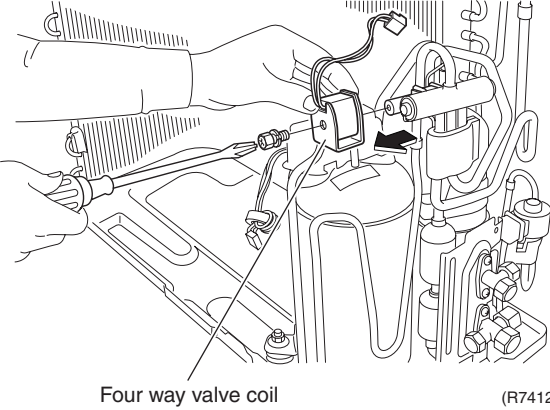
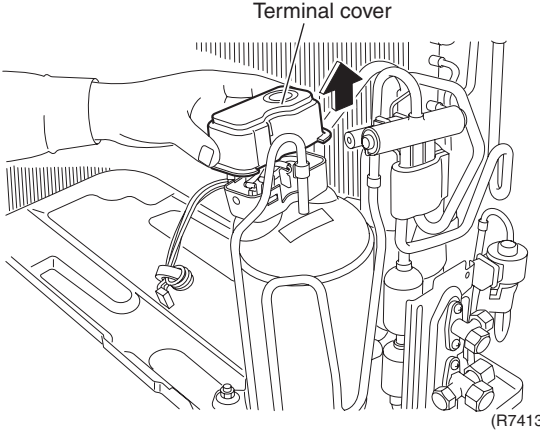
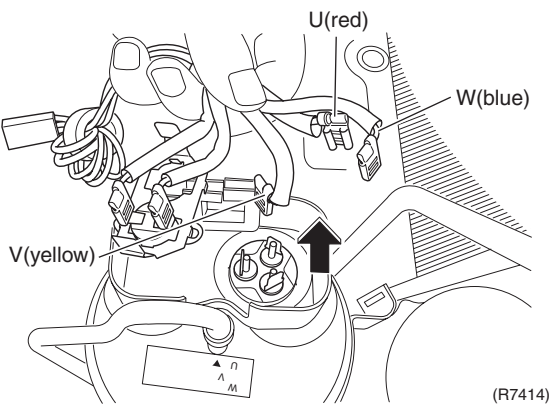
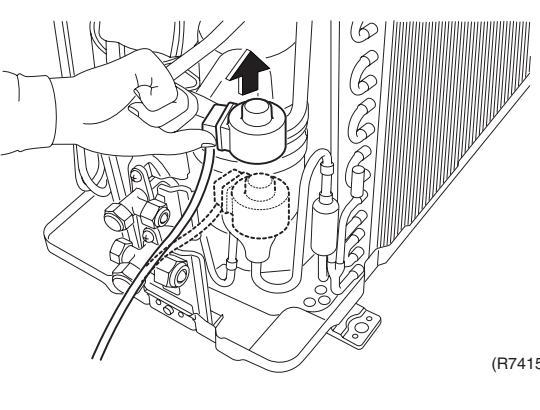

**Warning** Be sure to wait 10 minutes or more after turning off all power supplies before disassembling work.

Step	Procedure	Points
<p>1. Remove the peripheries.</p> <p>1. Loosen the screw of the four way valve coil.</p> <p>2. Remove the terminal cover.</p> <p>3. Disconnect the terminal.</p> <p>4. Remove the electronic expansion valve coil.</p>	<p>■ Remove the four way valve and the sheets of putty so as not to burn them.</p>    	<p>■ Be careful so as not to burn the compressor terminals or the name plate.</p> <p>Make a note.                  U: Red                  V: Yellow                  W: Blue</p>

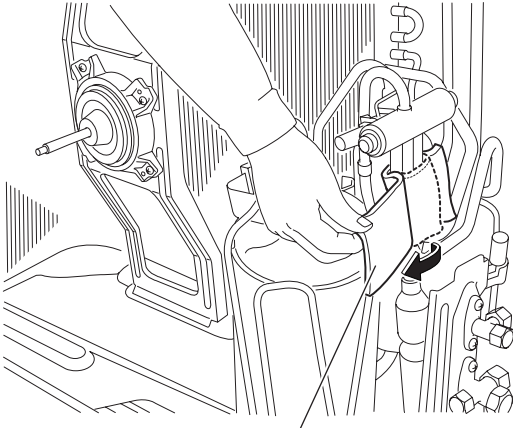
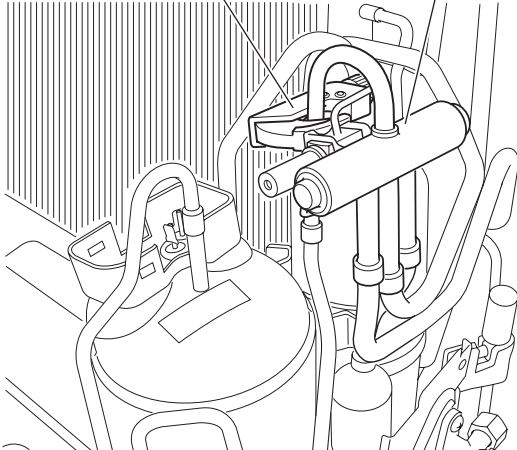
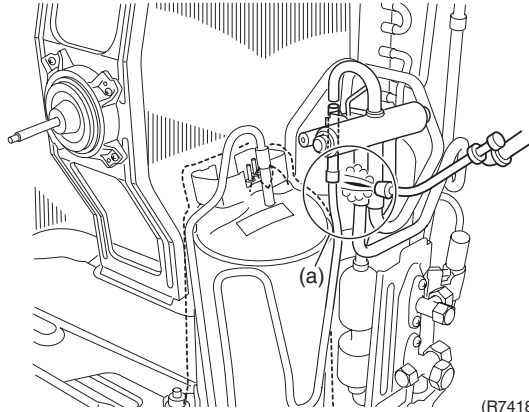

Step	Procedure	Points
5	Remove the putty.  <p style="text-align: center;">Putty (R7416)</p>	
6	Cut the pipe with a tube cutter. <ul style="list-style-type: none"> <li>■ Before working, make sure that the refrigerant is empty in the circuit.</li> <li>■ Be sure to apply nitrogen replacement when heating up the brazed part.</li> </ul>  <p style="text-align: center;">Tube cutter      Four way valve coil (R7417)</p>	<p><b>⚠ Caution</b>  <b>Be careful not to get yourself burnt with the pipes and other parts that are heated by the gas welding rod.</b></p> <p><b>⚠ Caution</b>  <b>From the viewpoint of global environment protection, do not discharge the refrigerant gas in the atmosphere. Make sure to recover the refrigerant gas with the recovery system.</b></p>
2.	Remove the four way valve.	<b>Reassembling precautions</b>
1	Heat up the brazed part (a) and withdraw the piping with pliers.  <p style="text-align: center;">(a) (R7418)</p>	<ol style="list-style-type: none"> <li>1. Use non-oxidizing brazing method. If nitrogen gas is not available, braze the parts speedily.</li> <li>2. Avoid deterioration of the gaskets due to carbonization of oil inside the four way valve or thermal influence. For this purpose, wrap the four way valve with wet cloth. Splash water over the cloth against becoming too hot (keep it below 120°C).</li> </ol>

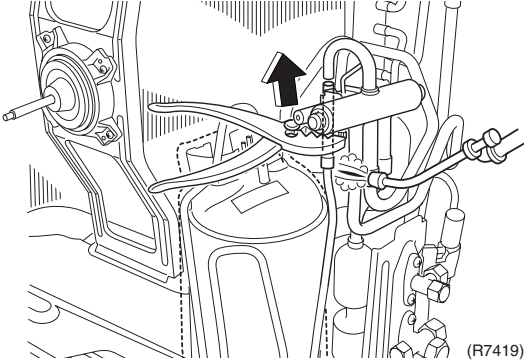
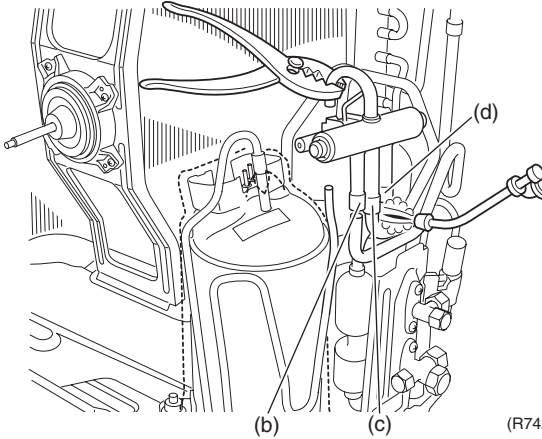
Step	Procedure	Points
2	Heat the 3 brazed points of the four way valve. Disconnect the point (b) first.	<ul style="list-style-type: none"> <li>■ In pulling the pipes, be careful not to over-tighten them with pliers. The pipes may get deformed.</li> </ul>
3	Disconnect the points (c) and (d).	<p>If the gas welding machine fails to remove the four way valve, take the steps below.</p>
<p><b>Warning</b>   If refrigerant gas leaks during the job, ventilate the room. (Bear in mind that if the refrigerant gas is exposed to open flames, noxious gas may be generated.)</p>		<ol style="list-style-type: none"> <li>1. Disconnect the brazed pipe sections that are readily easy to separate and join together later.</li> <li>2. With a small copper tube cutter, cut off the internal pipes to easily take out the four way valve.</li> </ol>
 <p>(R7419)</p>		<p><b>Note:</b>                  Never use a hack saw. The sawdust may come into the circuit.</p>
 <p>(b) (c) (d) (R7420)</p>		

## 6. Removal of Compressor

### Procedure

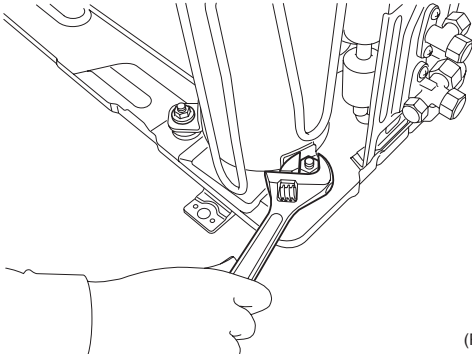
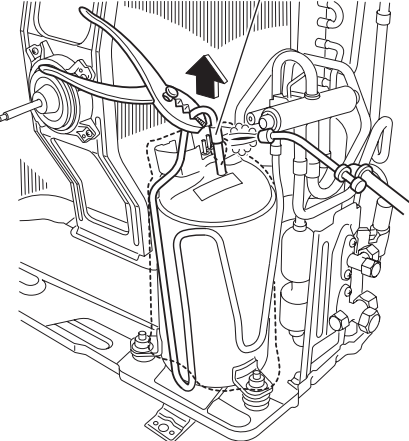
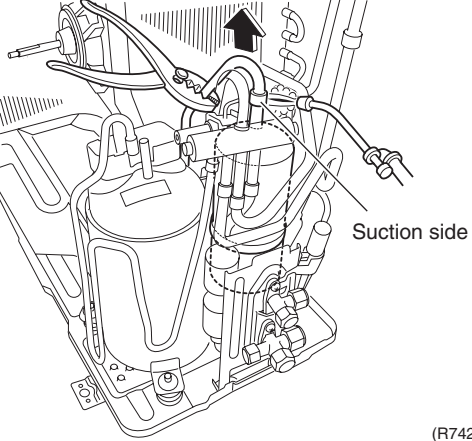
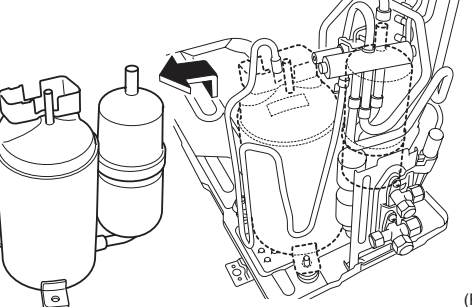

**Warning** Be sure to wait 10 minutes or more after turning off all power supplies before disassembling work.

Step	Procedure	Points
<p>1. Remove the peripheries.</p> <p>1. Unscrew the nut of the compressor.</p> <ul style="list-style-type: none"> <li>■ Remove the four way valve, the terminal cover and the lead wire for compressor so as not to burr them.</li> </ul>	 <p style="text-align: right;">(R7421)</p>	<p><b>Warning</b> Ventilate when refrigerant leaks during the work. (If refrigerant contacts fire, it will cause to arise toxic gas.)</p> <ul style="list-style-type: none"> <li>■ Provide a protective sheet or a steel plate so that the brazing flame cannot influence peripheries.</li> <li>■ Be careful so as not to burn the compressor terminals or the name plate.</li> <li>■ Be careful so as not to burn the heat exchanger fin.</li> </ul>
<p>2. Remove the compressor.</p> <p>1. Heat up the brazed part of the discharge side and disconnect.</p> <p>2. Heat up the brazed part of the suction side and disconnect.</p> <p>3. Lift the compressor up and remove it.</p> <p><b>Caution</b> From the viewpoint of global environment protection, do not discharge the refrigerant gas in the atmosphere. Make sure to recover the refrigerant gas with the recovery system.</p> <p><b>Caution</b> From the viewpoint of global environment protection, make sure to use the vacuum pump for air purge.</p>	<p style="text-align: center;">Discharge side</p>  <p style="text-align: right;">(R7422)</p>  <p style="text-align: right;">(R7423)</p>  <p style="text-align: right;">(R7424)</p>	<p><b>Warning</b> Since it may happen that refrigeration oil in the compressor will catch fire, prepare wet cloth so as to extinguish fire immediately.</p> <p><b>In case of the difficulty with gas brazing machine</b></p> <ol style="list-style-type: none"> <li>1. Disconnect the brazed part where is easy to disconnect and restore.</li> <li>2. Cut pipes on the main unit by a miniature copper tube cutter in order to make it easy to disconnect.</li> </ol> <p><b>Cautions for restoration</b></p> <ol style="list-style-type: none"> <li>1. Restore the piping by non-oxidation brazing.</li> <li>2. It is required to prevent the carbonization of the oil inside the four way valve and the deterioration of the gaskets affected by heat. For the sake of this, wrap the four way valve with wet cloth and provide water so that the cloth will not be dried and avoid excessive heating. (Keep below 120°C)</li> </ol> <p><b>Note:</b> Do not use a metal saw for cutting pipes by all means because the sawdust come into the circuit.</p>

# Revision History

Month / Year	Version	Revised contents
07 / 2013	Si00-778	First edition

Warning



- Daikin products are manufactured for export to numerous countries throughout the world. Prior to purchase, please confirm with your local authorised importer, distributor and/or retailer whether this product conforms to the applicable standards, and is suitable for use, in the region where the product will be used. This statement does not purport to exclude, restrict or modify the application of any local legislation.
- Ask a qualified installer or contractor to install this product. Do not try to install the product yourself. Improper installation can result in water or refrigerant leakage, electrical shock, fire or explosion.
- Use only those parts and accessories supplied or specified by Daikin. Ask a qualified installer or contractor to install those parts and accessories. Use of unauthorised parts and accessories or improper installation of parts and accessories can result in water or refrigerant leakage, electrical shock, fire or explosion.
- Read the User's Manual carefully before using this product. The User's Manual provides important safety instructions and warnings. Be sure to follow these instructions and warnings.

If you have any enquiries, please contact your local importer, distributor and/or retailer.

### Cautions on product corrosion

1. Air conditioners should not be installed in areas where corrosive gases, such as acid gas or alkaline gas, are produced.
2. If the outdoor unit is to be installed close to the sea shore, direct exposure to the sea breeze should be avoided. If you need to install the outdoor unit close to the sea shore, contact your local distributor.

### Dealer

### **DAIKIN INDUSTRIES, LTD.**

Head Office:  
Umeda Center Bldg., 2-4-12, Nakazaki-Nishi,  
Kita-ku, Osaka, 530-8323 Japan

Tokyo Office:  
JR Shinagawa East Bldg., 2-18-1, Konan,  
Minato-ku, Tokyo, 108-0075 Japan

[http://www.daikin.com/global\\_ac/](http://www.daikin.com/global_ac/)

©All rights reserved