

REMOVAL PROCEDURE



SERVICE
MANUAL

S E R V I C E M A N U A L

2.8/4.2/5.0 kW Class

-  Outdoor Unit
-  Inverter
-  Pair Type

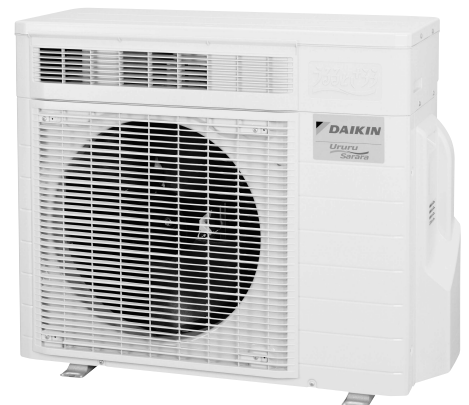

Service Manual Removal Procedure

Outdoor Unit

●Heat Pump

RXR28EV1B9

RXR42EV1B9

RXR50EV1B9

RXR28FVLT

RXR50FVLT

Table of Contents

1. Removal of Humidifier Unit	2
2. Removal of Heater Assembly / Humidifying Rotor / Humidifying Rotor Motor	5
3. Removal of Humidifying Fan Assembly	9
4. Removal of Hygroscopic Fan Motor	12
5. Removal of Outdoor Fan / Fan Motor	13
6. Removal of Humidifying Duct.....	17
7. Removal of Electrical Box	18
8. Removal of PCB.....	22
9. Removal of Sound Blankets.....	25
10. Removal of Thermistor Assembly	27
11. Removal of Reactor / Partition Plate	29
12. Removal of Four Way Valve	30
13. Removal of Electronic Expansion Valve	32
14. Removal of Compressor	33



Note:

- ♦ The illustrations may be slightly different depending on the model.

1. Removal of Humidifier Unit

Procedure

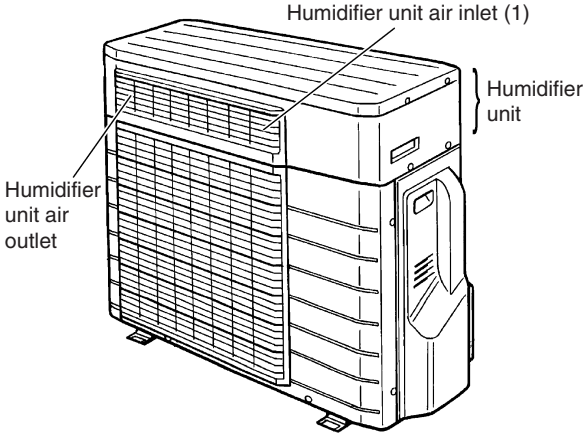
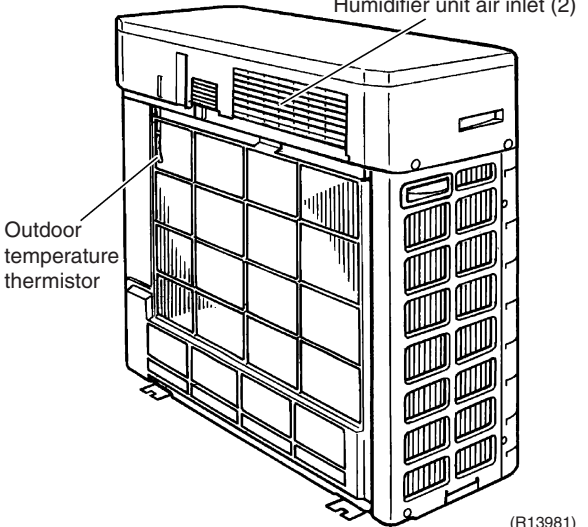
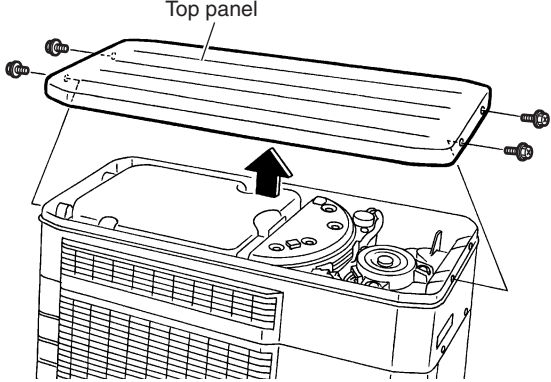

Warning Be sure to wait for 10 minutes or more after turning off all power supplies before disassembling work.

Step	Procedure	Points
<p>1. External appearance</p>	 <p>(R13980)</p>  <p>(R13981)</p>	
<p>2. Remove the top panel.</p> <p>1 Remove the 4 screws and remove the top panel.</p>	 <p>(R13982)</p>	

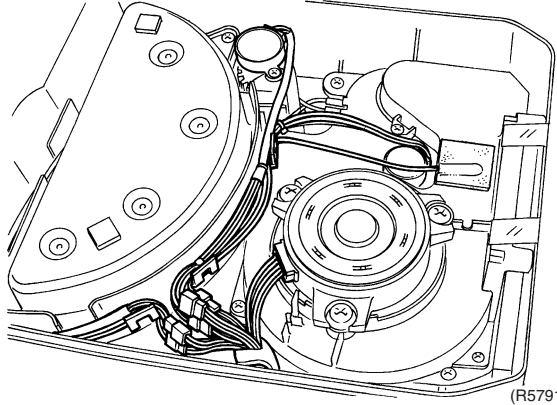
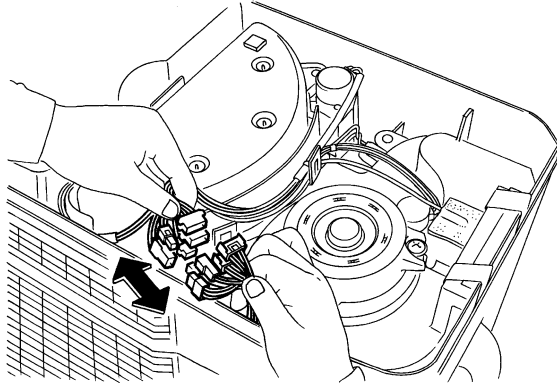
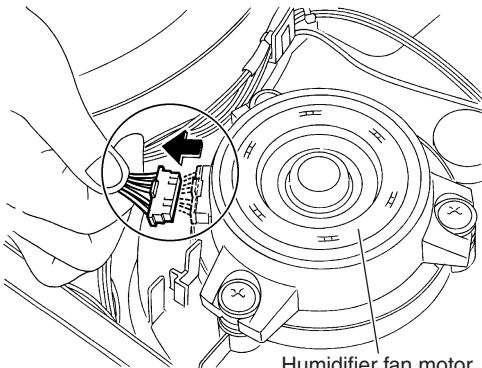
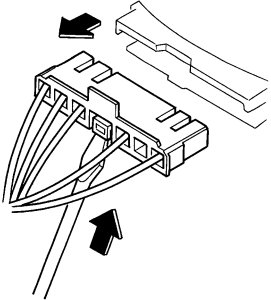
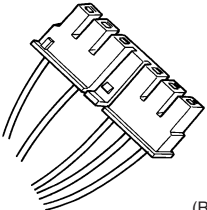
Step	Procedure	Points
3. Remove the humidifier unit.		
1	<p>The figure shows the arrangement of the relay harnesses.</p>  <p>(R5791)</p>	<ul style="list-style-type: none"> Be sure to wait for 10 minutes or more after turning off the power supply before disconnecting the connectors.
2	<p>Disconnect the 5 relay connectors.</p>  <p>(R5792)</p>	
3	<p>Disconnect the connector for the humidifier fan motor.</p>  <p>Humidifier fan motor (R13983)</p>	<ul style="list-style-type: none"> Pull out the connector while pushing up the hook on the bottom side.  <p><From the back side></p>  <p>(R5796)</p>

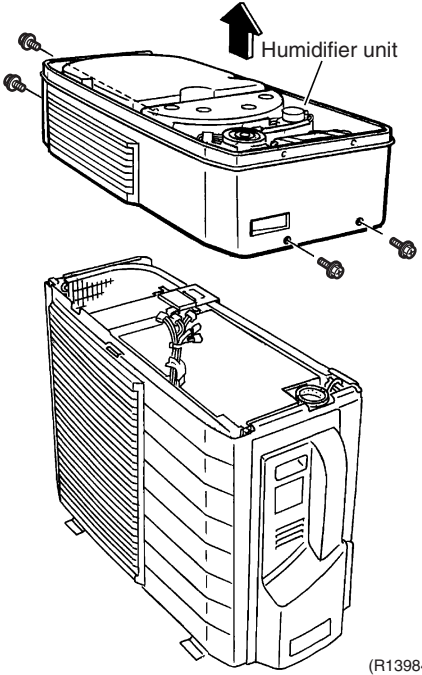
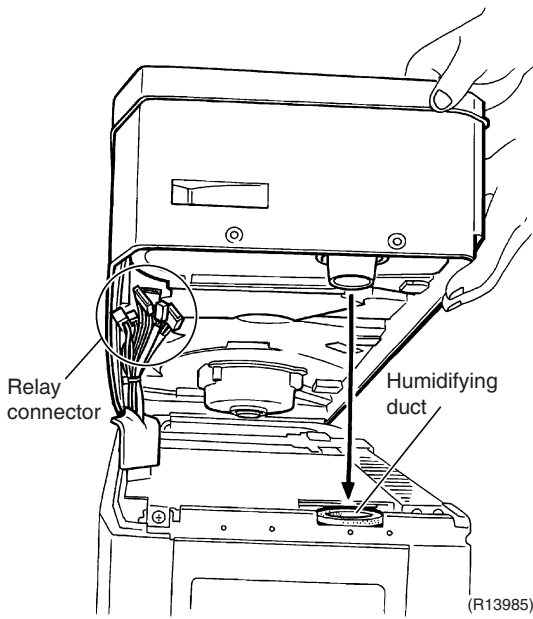
Step	Procedure	Points
<p>4</p>	<p>Remove the 4 screws of the humidifier unit and lift it up to remove.</p>  <p>(R13984)</p>	
<p>5</p>	<p>The figure shows the positions of the humidifying duct and the relay connectors.</p>  <p>(R13985)</p>	<ul style="list-style-type: none"> ■ When installing the humidifier unit, do not forget to connect the relay connectors.

2. Removal of Heater Assembly / Humidifying Rotor / Humidifying Rotor Motor

Procedure

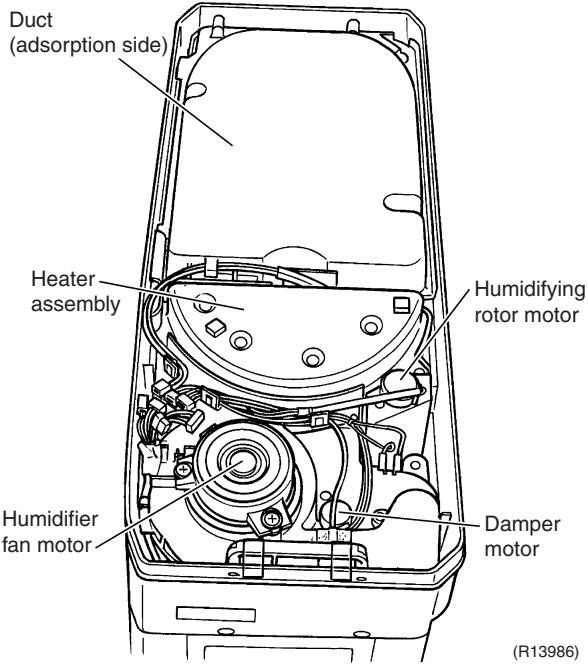
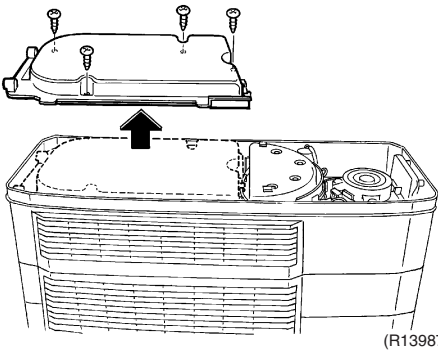
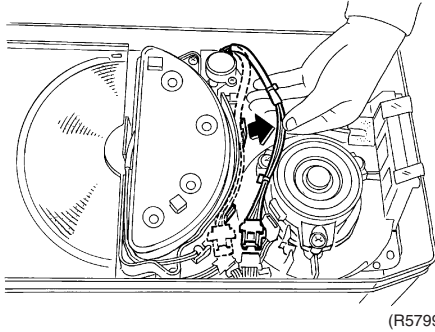

Warning Be sure to wait for 10 minutes or more after turning off all power supplies before disassembling work.

Step	Procedure	Points
1. Inside structure of the humidifier unit	 <p>Duct (adsorption side)</p> <p>Heater assembly</p> <p>Humidifying rotor motor</p> <p>Humidifier fan motor</p> <p>Damper motor</p> <p>(R13986)</p>	<p>Preparation</p> <ul style="list-style-type: none"> Remove the top panel according to "Removal of Humidifier Unit".
2. Remove the heater assembly.	<p>1 Remove the 4 screws of the duct on adsorption side.</p>  <p>(R13987)</p> <p>2 Release the lead wire for the humidifying rotor motor from the hooks.</p>  <p>(R5799)</p>	

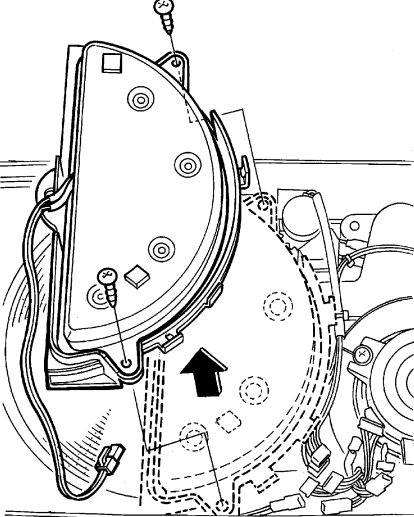
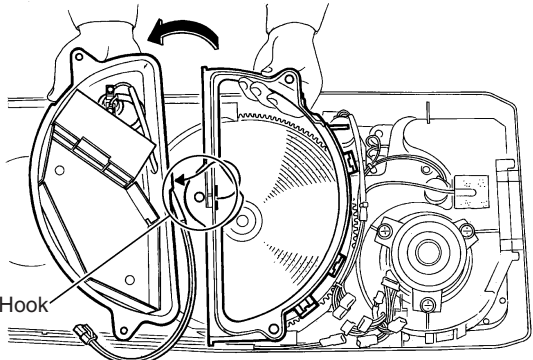
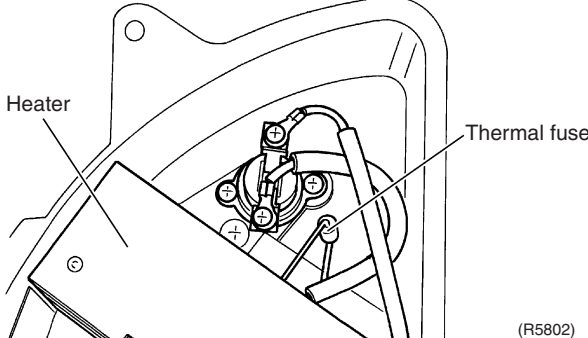
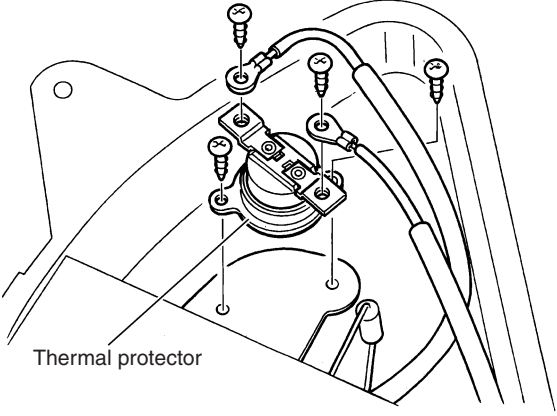
Step	Procedure	Points
3	<p>Remove the 2 screws and remove the heater assembly.</p>  <p style="text-align: right;">(R5800)</p>	<ul style="list-style-type: none"> ■ The heater assembly should be replaced as an assembly set. (Disassembling of the assembly may cause malfunction.)
4	<p>Unfasten the hook.</p>  <p style="text-align: right;">(R5801)</p>	
5	<p>Inside of the heater assembly.</p>  <p style="text-align: right;">(R5802)</p>	<ul style="list-style-type: none"> ■ Heater and thermal fuse should be replaced as the heater assembly.
6	<p>Loosen the 4 screws of the thermal protector.</p>  <p style="text-align: right;">(R5803)</p>	<ul style="list-style-type: none"> ■ The thermal protector is removable. Remove it before the lead wire.

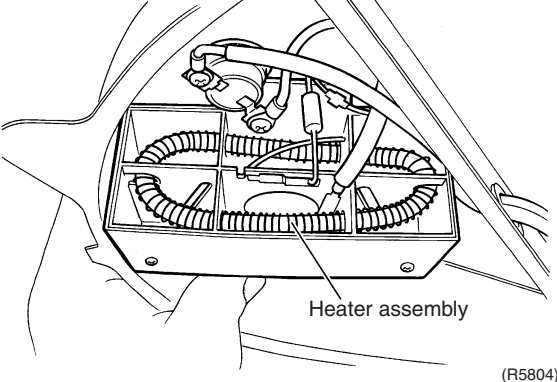
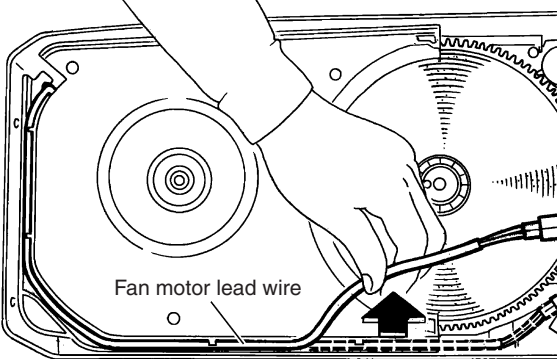
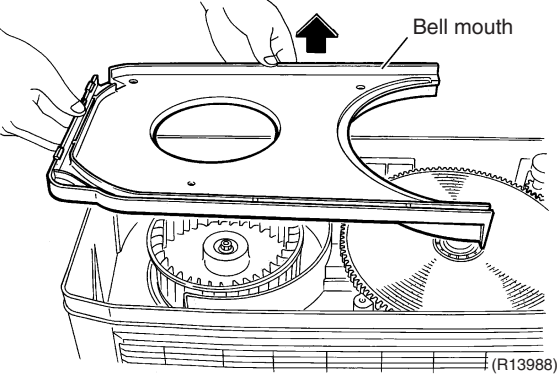
Step		Procedure	Points
7	Inside structure of the heater assembly.		
3. Remove the humidifying rotor.			
1	Release the fan motor lead wire from the hooks.		
2	Remove the bell mouth on adsorption side.		

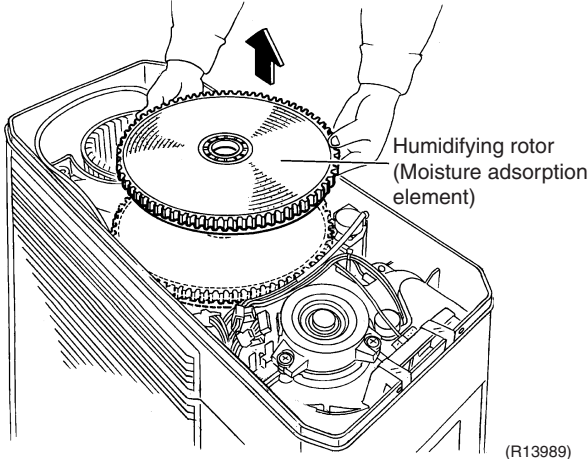
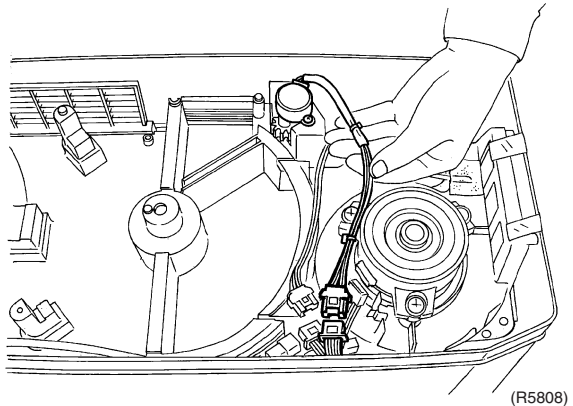
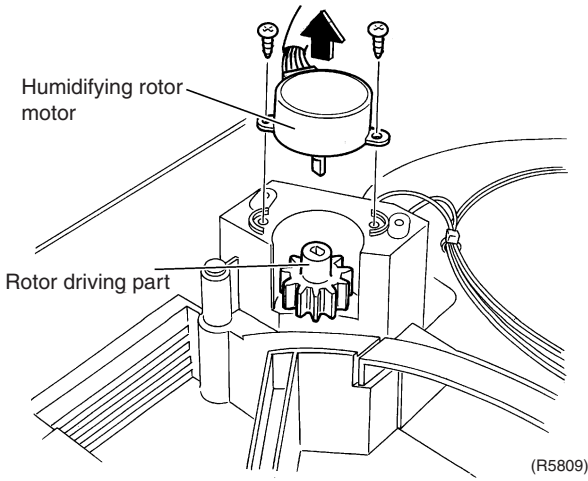
Step	Procedure	Points
3	<p>Lift the humidifying rotor up to remove.</p> 	<ul style="list-style-type: none"> ■ A heat catalyst (black) is applied on the upper side.
4.	<p>Remove the humidifying rotor motor.</p>	
1	<p>The figure shows the connector for the humidifying rotor motor.</p> 	
2	<p>Remove the 2 screws and remove the humidifying rotor motor.</p> 	

3. Removal of Humidifying Fan Assembly

Procedure

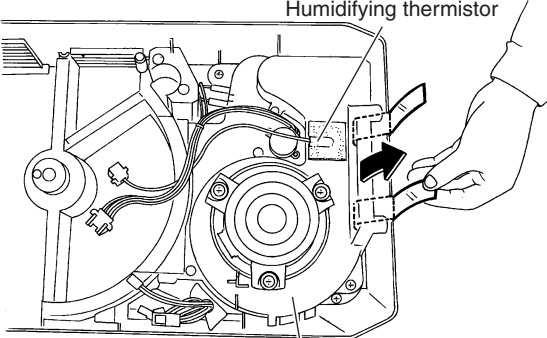
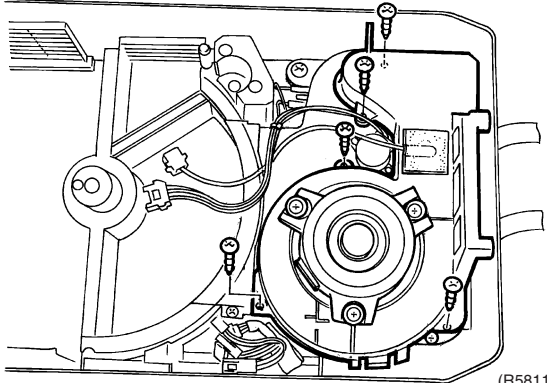
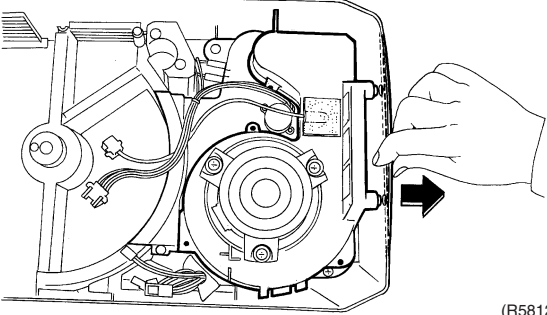

Warning Be sure to wait for 10 minutes or more after turning off all power supplies before disassembling work.

Step	Procedure	Points
1. Remove the humidifying fan assembly.		Preparation ■ Remove the humidifier unit according to "Removal of Humidifier Unit".
1 Peel off the 2 tapes.	 <p style="text-align: right;">(R13990)</p>	
2 Remove the 5 screws of the humidifying fan assembly.	 <p style="text-align: right;">(R5811)</p>	
3 Unfasten the 2 hooks while bending the right side panel.	 <p style="text-align: right;">(R5812)</p>	

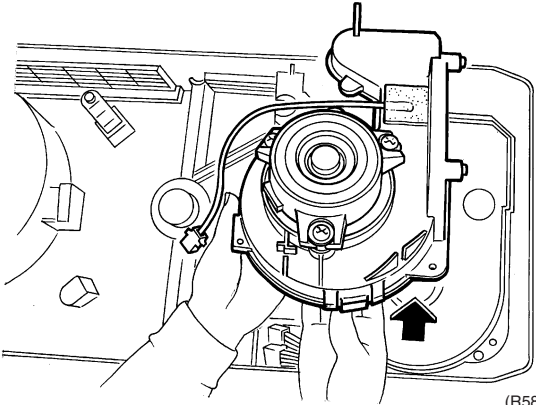
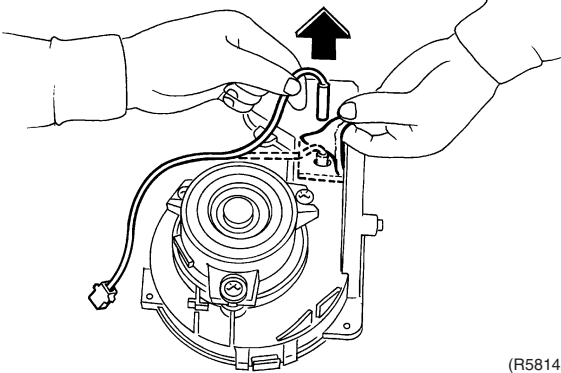
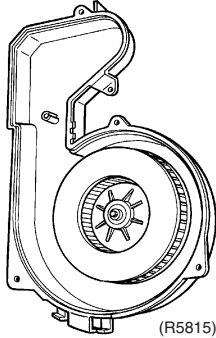
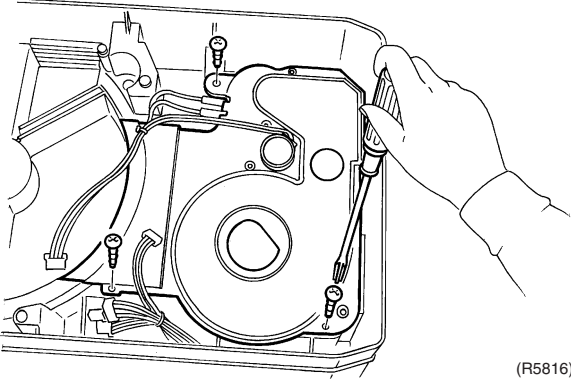
Step	Procedure	Points	
4	Remove the humidifying fan assembly.	 <p>(R5813)</p>	<ul style="list-style-type: none"> ■ The humidifying fan assembly should be replaced as an assembly set. (Disassembling of the assembly can cause a noise.)
5	Peel the seal material and pull out the humidifying thermistor.	 <p>(R5814)</p>	 <p>(R5815)</p> <ul style="list-style-type: none"> ■ Inside of the upper part of the humidifying fan assembly
2.	Remove the damper assembly.		
1	Remove the 3 screws.	 <p>(R5816)</p>	

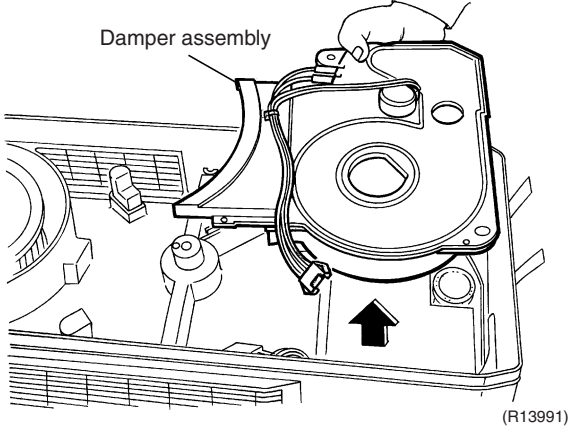
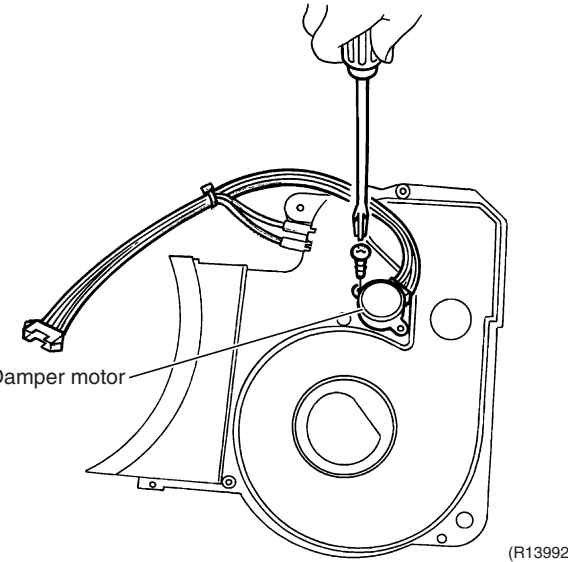
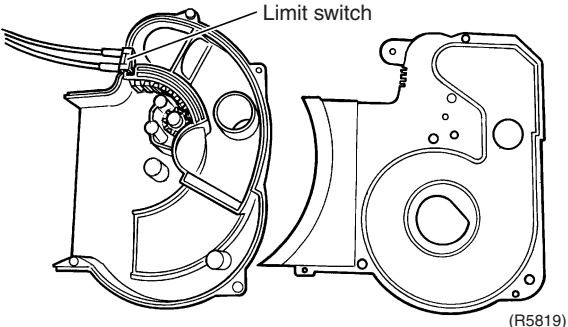
Step	Procedure	Points
2	<p>Remove the damper assembly.</p>  <p>(R13991)</p>	
3	<p>Remove the screw and remove the damper motor.</p>  <p>(R13992)</p>  <p>(R5819)</p>	

4. Removal of Hygroscopic Fan Motor

Procedure



Warning Be sure to wait for 10 minutes or more after turning off all power supplies before disassembling work.

Step	Procedure	Points
1	<p>Remove the nut and remove the hygroscopic fan.</p>	<p>Preparation</p> <ul style="list-style-type: none"> Remove the humidifying rotor according to "Removal of Heater Assembly / Humidifying Rotor / Humidifying Rotor Motor". Nut size: M6
2	<p>Remove the 3 screws of the motor cover.</p>	
3	<p>Remove the motor cover.</p>	<ul style="list-style-type: none"> When reassembling, align the ▼ mark of the outdoor fan with the D-cut section of the motor shaft.
4	<p>Remove the hygroscopic fan motor.</p>	

5. Removal of Outdoor Fan / Fan Motor

Procedure

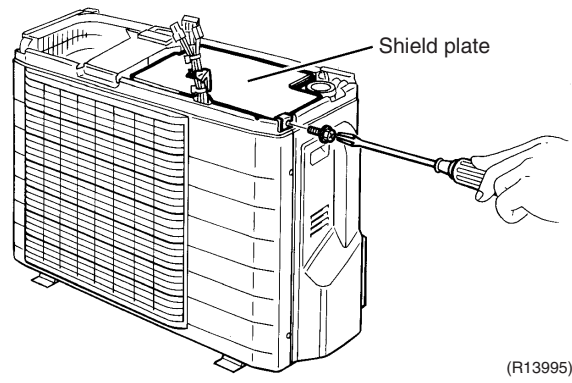
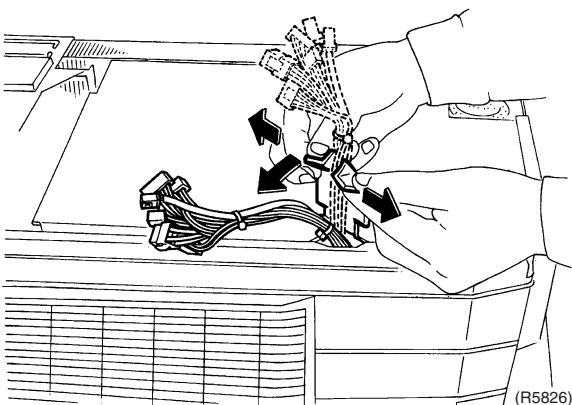
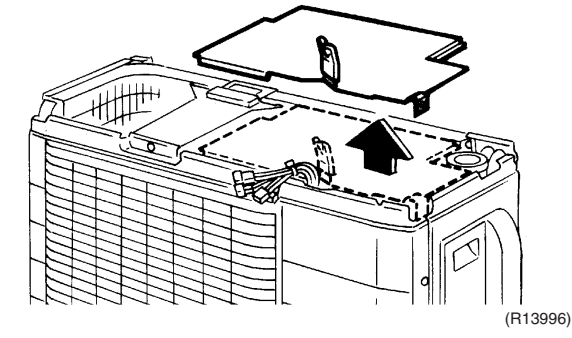
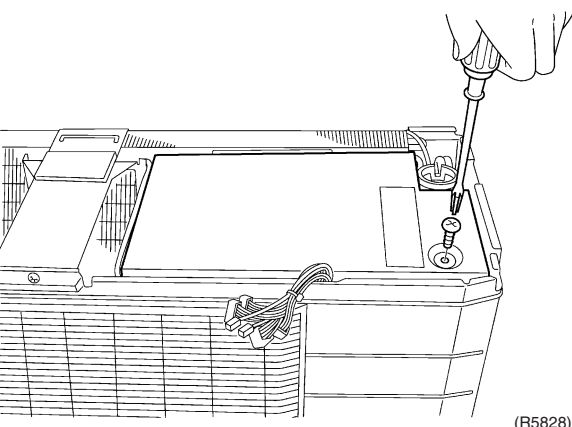

Warning Be sure to wait for 10 minutes or more after turning off all power supplies before disassembling work.

Step	Procedure	Points
<p>1. Remove the shield plate.</p> <p>1 Remove the screw.</p> <p>2 Open the fixing plate and release the harnesses.</p> <p>3 Remove the shield plate.</p>	 <p style="text-align: right;">(R13995)</p>  <p style="text-align: right;">(R5826)</p>  <p style="text-align: right;">(R13996)</p>	<p>Preparation</p> <ul style="list-style-type: none"> ■ Remove the humidifier unit according to "Removal of Humidifier Unit". ■ Be careful not to forget to install, not to lose, and not to break the shield plate and the electrical box cover.
<p>2. Remove the electrical box cover.</p> <p>1 Remove the screw.</p>	 <p style="text-align: right;">(R5828)</p>	

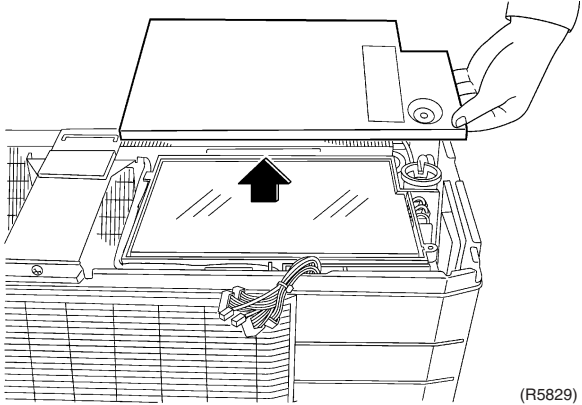
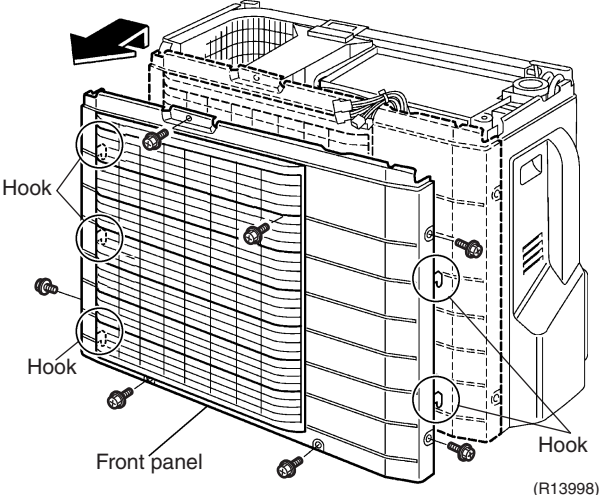
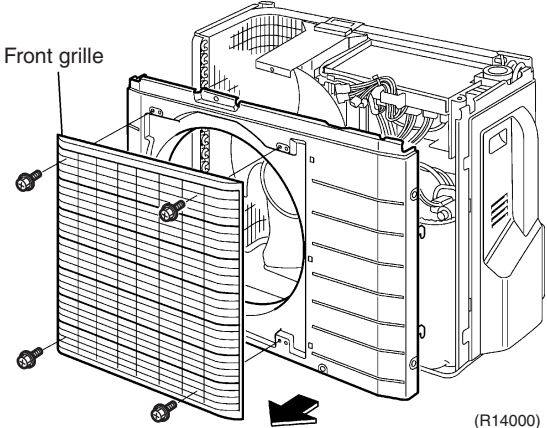
Step	Procedure	Points
<p>2 Remove the electrical box cover.</p>	 <p>(R5829)</p>	
<p>3 Remove the front panel.</p>	<p>1 Remove the 7 screws. Unfasten the 5 hooks in total and remove the front panel.</p>  <p>Hook</p> <p>Hook</p> <p>Front panel</p> <p>Hook</p> <p>(R13998)</p> <p>2 Remove the 4 screws and remove the front grille.</p>  <p>Front grille</p> <p>(R14000)</p>	

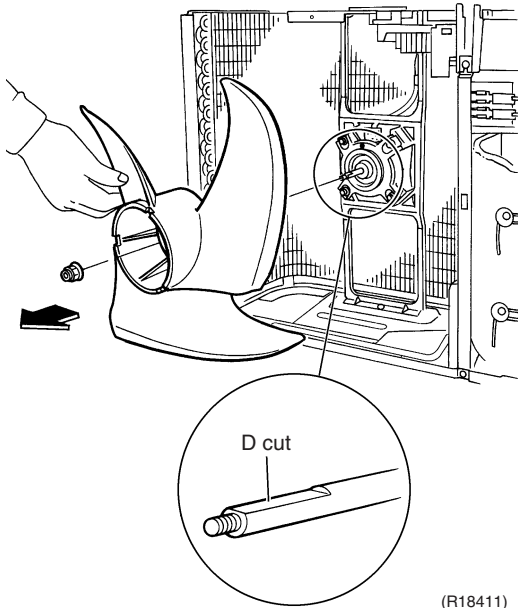
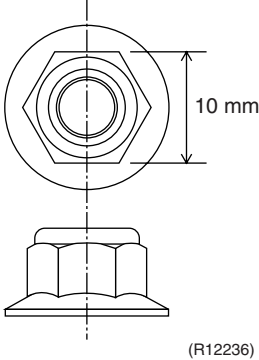
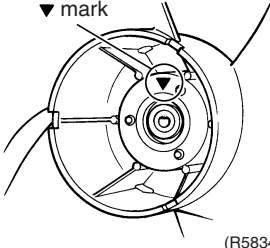
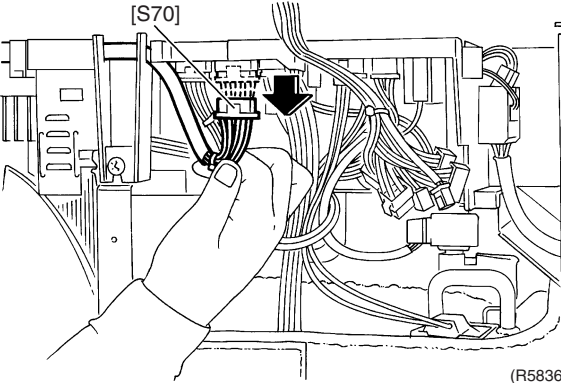
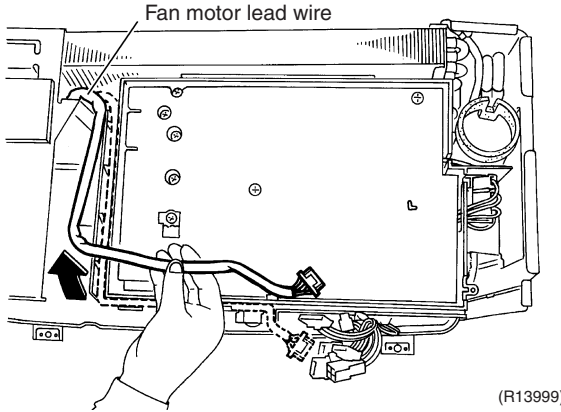
Step	Procedure	Points
<p>4. Remove the outdoor fan.</p> <p>1 Remove the nut and remove the outdoor fan.</p>	 <p>(R18411)</p>	<p>■ Nut size: M6</p>  <p>(R12236)</p> <p>■ When reassembling, align the ▼ mark of the outdoor fan with the D-cut section of the motor shaft.</p>  <p>(R5834)</p>
<p>5. Remove the fan motor.</p> <p>1 Disconnect the connector for the fan motor [S70].</p> <p>2 Release the fan motor lead wire from the hooks.</p>	 <p>(R5836)</p>  <p>(R13999)</p>	

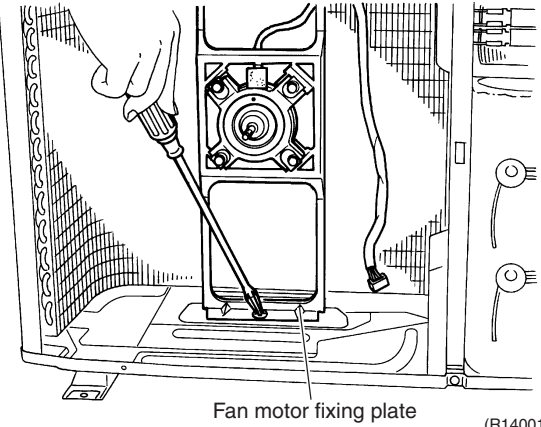
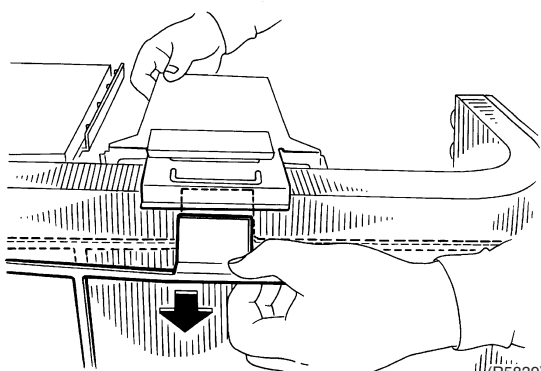
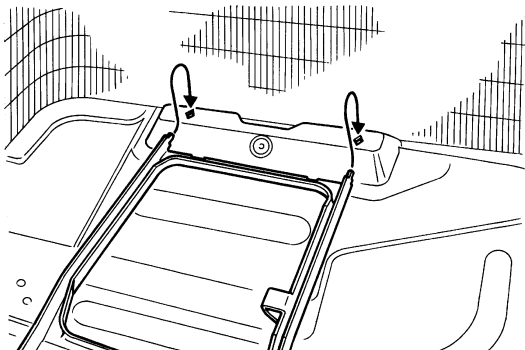
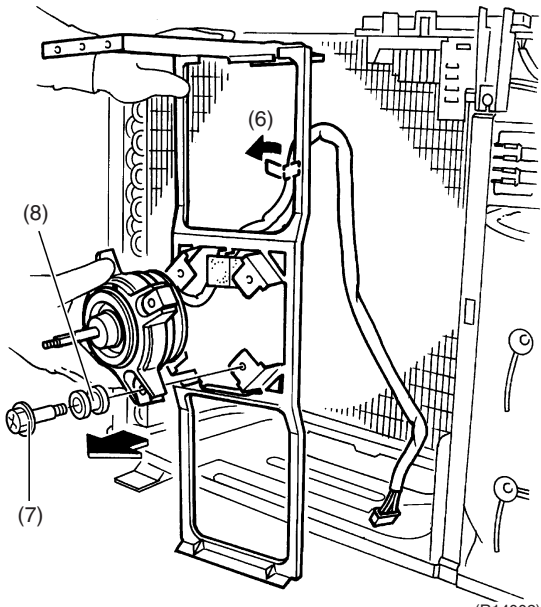
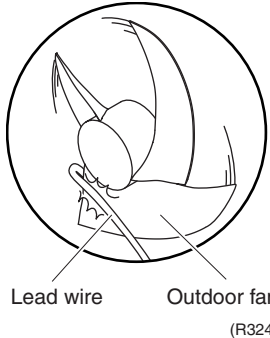
Step	Procedure	Points
3	<p>Remove the screw of the fan motor fixing plate.</p> 	
4	<p>Detach the upper part of the fan motor fixing plate.</p> 	
5	<p>Fan motor fixing plate has 2 hooks on lower part.</p> 	
6	<p>Unfasten the hook and release the fan motor lead wire.</p>	<p>■ When reassembling, put the fan motor lead wire through the back of the fan motor (so as not to be entangled with the outdoor fan).</p>
7	<p>Remove the 4 screws of the fan motor.</p>	
8	<p>Pull out the rubber vibration isolators sideward.</p> 	

6. Removal of Humidifying Duct

Procedure

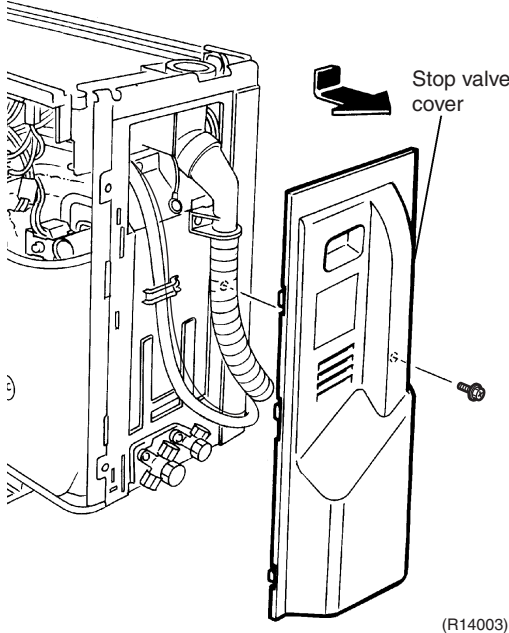
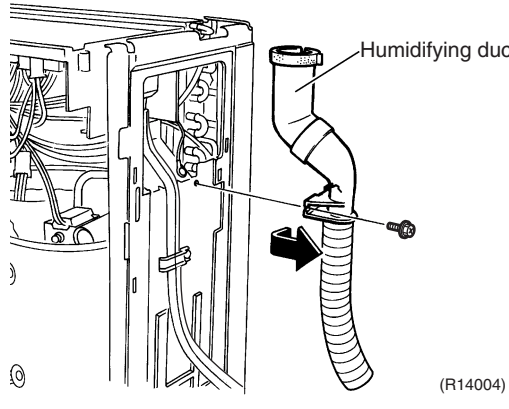

Warning Be sure to wait for 10 minutes or more after turning off all power supplies before disassembling work.

Step	Procedure	Points
1	Remove the screw and remove the stop valve cover.	 <p>(R14003)</p>
2	Remove the screw and remove the humidifying duct.	 <p>(R14004)</p>

- When reassembling, make sure to catch the hook.

7. Removal of Electrical Box

Procedure

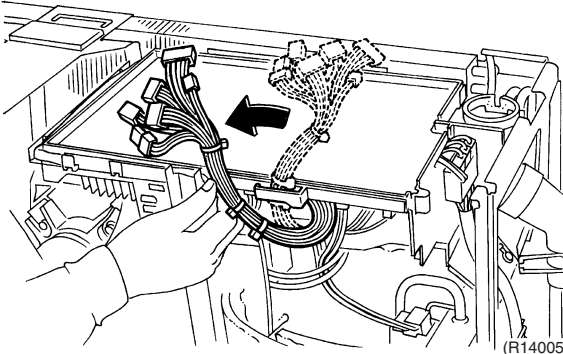
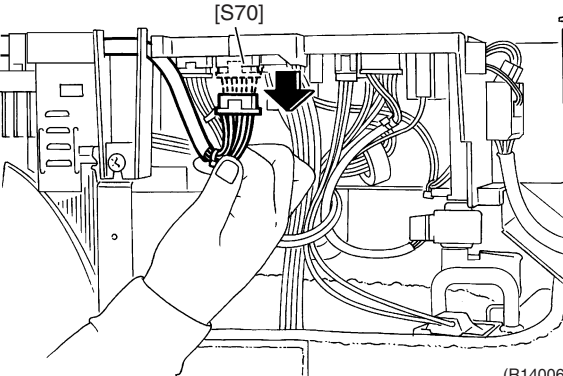
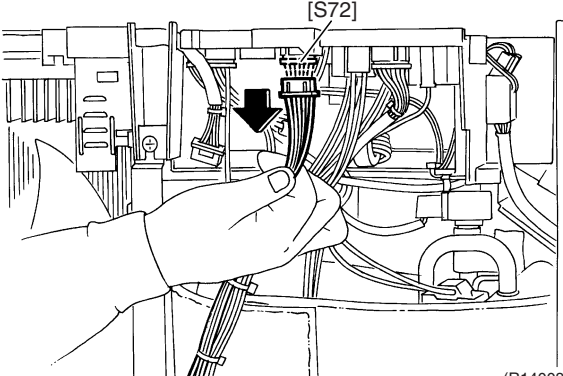
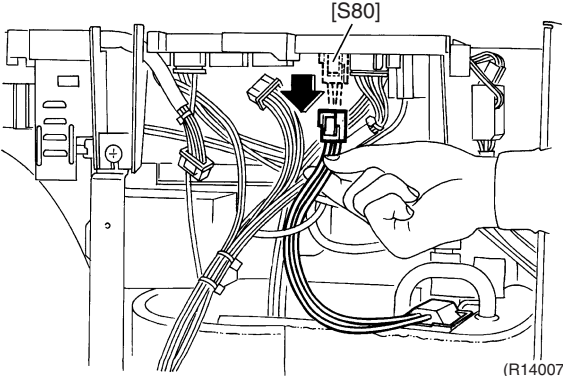

Warning Be sure to wait for 10 minutes or more after turning off all power supplies before disassembling work.

Step	Procedure	Points
1	Release the harnesses for the humidifier unit from the hook.	<p>Preparation</p> <ul style="list-style-type: none"> Remove the front panel according to "Removal of Outdoor Fan / Fan Motor".
2	Disconnect the connector for the fan motor [S70].	 <p>(R14005)</p>
3	Disconnect the connector for the humidifier fan motor [S72].	 <p>(R14006)</p>  <p>(R14008)</p>
4	Disconnect the connector for the four way valve coil [S80].	 <p>(R14007)</p>

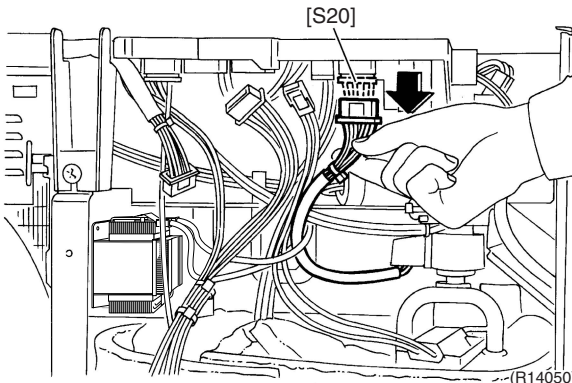
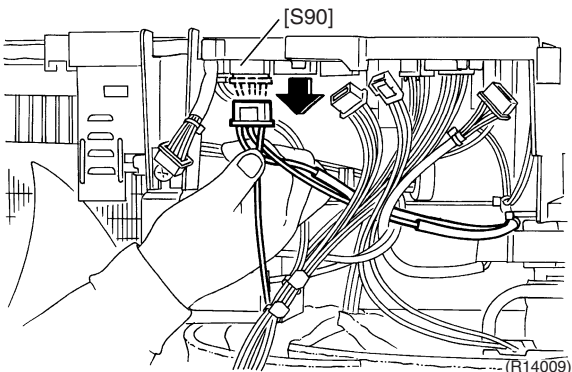
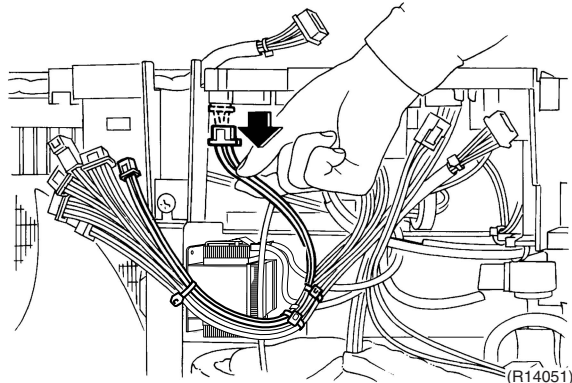
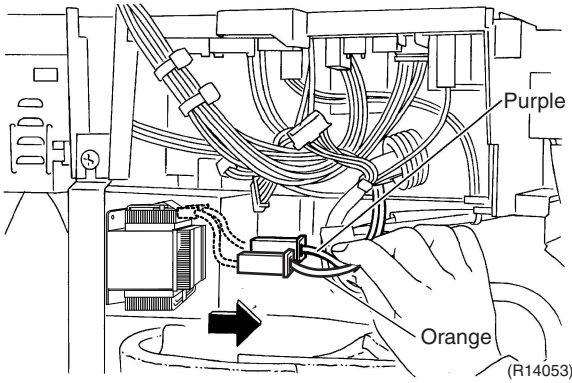
Step	Procedure	Points
5	<p>Disconnect the connector for the electronic expansion valve coil [S20].</p> 	
6	<p>Disconnect the connector for the thermistor assembly [S90].</p> 	
7	<p>Disconnect the connector for the humidifying thermistor [S91].</p> 	
8	<p>Disconnect the 2 terminals from the reactor.</p> 	

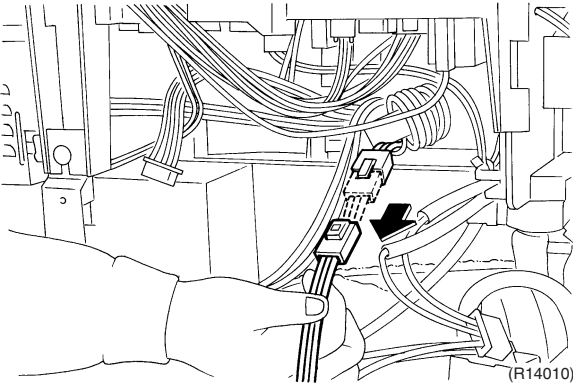
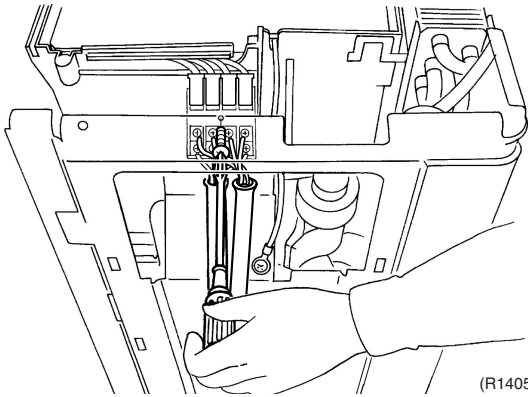
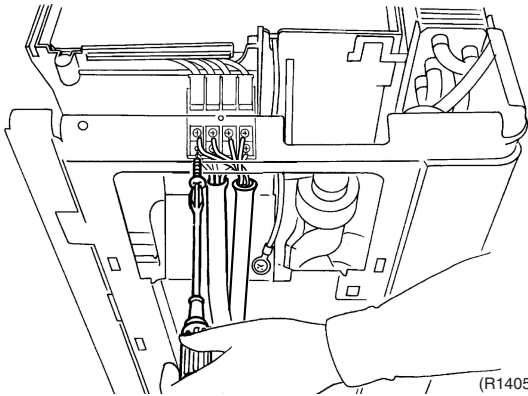
Step	Procedure	Points
9	<p>Disconnect the relay harness for the compressor.</p>  <p>(R14010)</p>	
10	<p>Remove the screw of the terminal board.</p>  <p>(R14052)</p>	<ul style="list-style-type: none"> ■ Thermal fuse should be replaced with the terminal board. ■ You can work without removing the terminal board.
11	<p>Remove the screws and disconnect the connecting wires and the power supply cables.</p>  <p>(R14054)</p>	

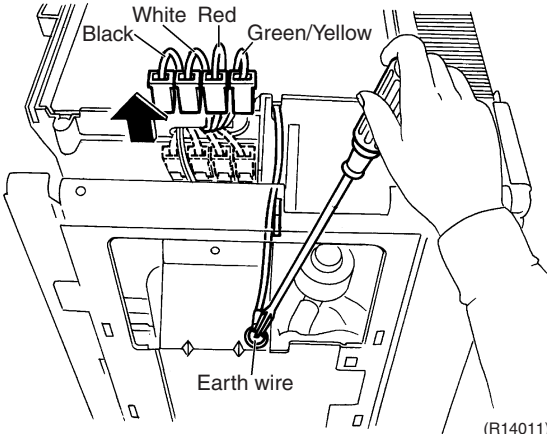
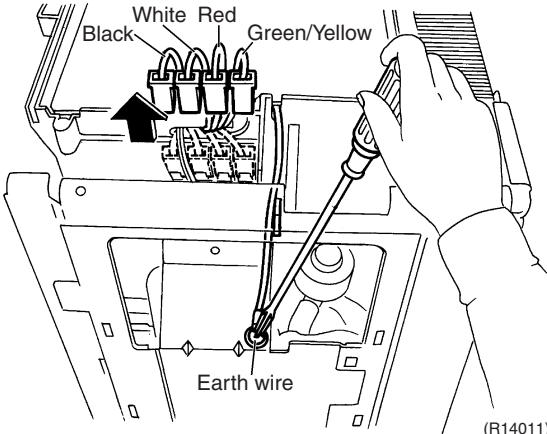
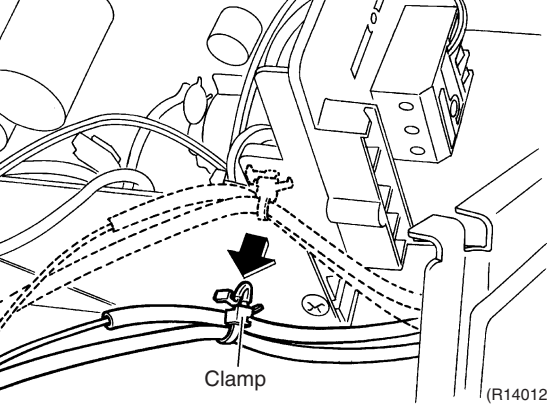
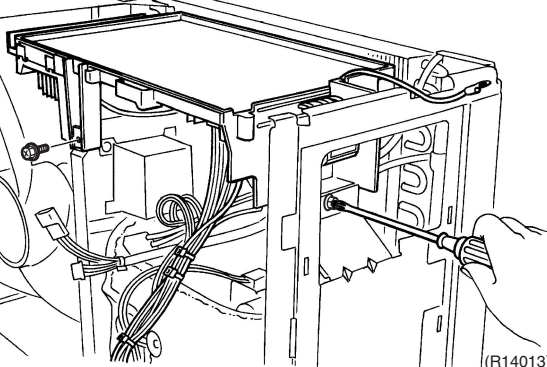
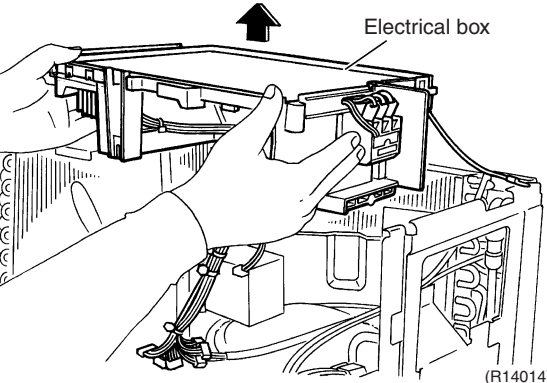
Step	Procedure	Procedure	Points
12	Disconnect the 4 connectors.	 <p>White Red Black Green/Yellow Earth wire</p> <p>(R14011)</p>	
13	Remove the screw and detach the earth wire.	 <p>Earth wire</p> <p>(R14011)</p>	
14	Detach the clamp for the thermistor assembly from the electrical box.	 <p>Clamp</p> <p>(R14012)</p>	
15	Remove the 2 screws of the electrical box.	 <p>(R14013)</p>	
16	Lift the electrical box and remove it.	 <p>Electrical box</p> <p>(R14014)</p>	

8. Removal of PCB

Procedure



Warning Be sure to wait for 10 minutes or more after turning off all power supplies before disassembling work.

Step	Procedure	Points
<p>1 Remove the 7 screws.</p>	<p>(R14015)</p>	<p>Preparation</p> <ul style="list-style-type: none"> ■ Remove the electrical box according to "Removal of Electrical Box".
<p>2 Detach the radiation fin.</p>	<p>(R5861)</p> <p>(R5862)</p> <p>Radiation fin</p>	<ul style="list-style-type: none"> ■ In working, be careful not to break the PCB with the excessive force because the PCB and the radiation fin are adhered to one another. ■ When reassembling, make sure to use the silicon material.

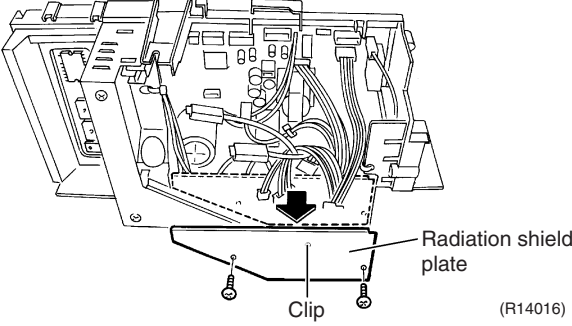
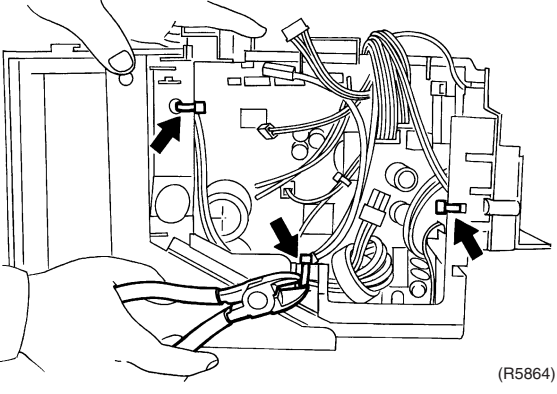
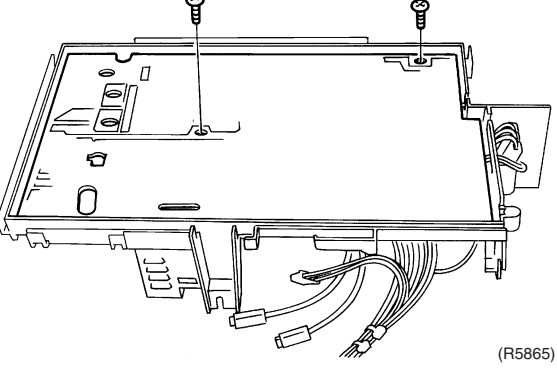
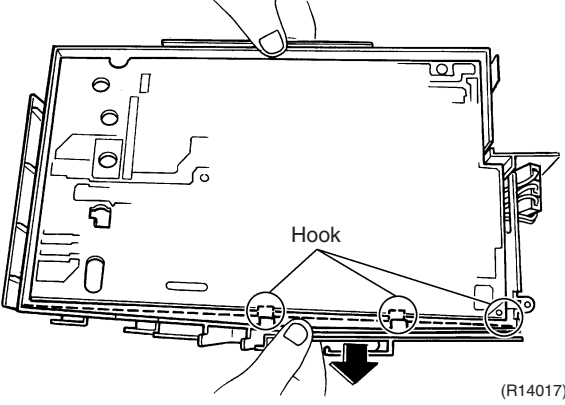
Step	Procedure	Points
3	<p>Remove the 2 screws and detach the clip to remove the radiation shield plate.</p> 	
4	<p>Cut the 3 clamps.</p> 	
5	<p>Remove the 2 screws.</p> 	
6	<p>Unfasten the 3 hooks of the electrical box.</p> 	

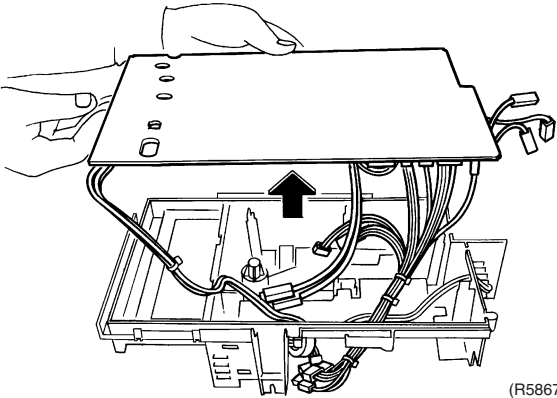
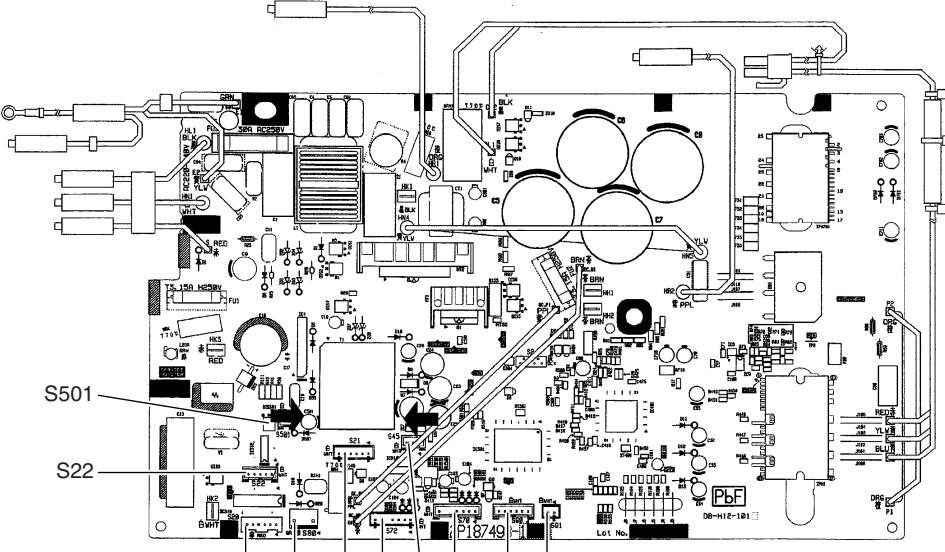
Step	Procedure	Points
7	Remove the PCB from the electrical box.  <p style="text-align: right;">(R5867)</p>	
8	Disconnect the connectors.  <p style="text-align: center;">S20 S80 S21 S72 S45 S70 S90 S91</p> <p style="text-align: right;">(R14168)</p>	<p>S20 : electronic expansion valve coil S21 : humidifying rotor motor S22 : damper motor S45 : thermal fuse S70 : fan motor S72 : humidifier fan motor S80 : four way valve coil S90 : thermistor assembly S91 : humidifying thermistor S501 : limit switch</p>

9. Removal of Sound Blankets

Procedure

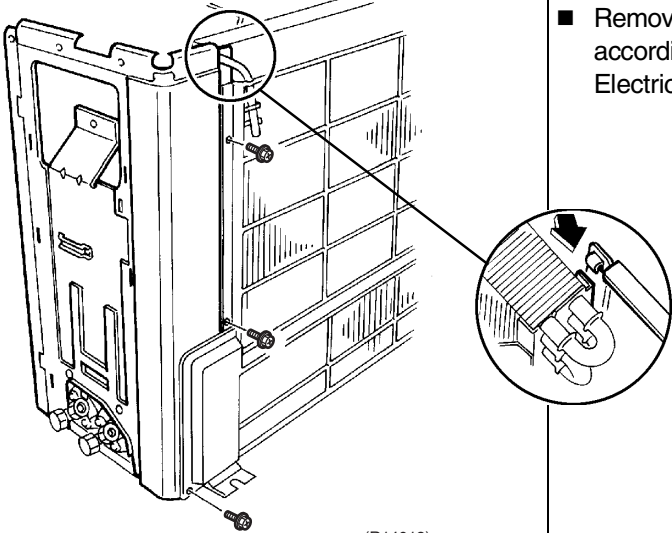
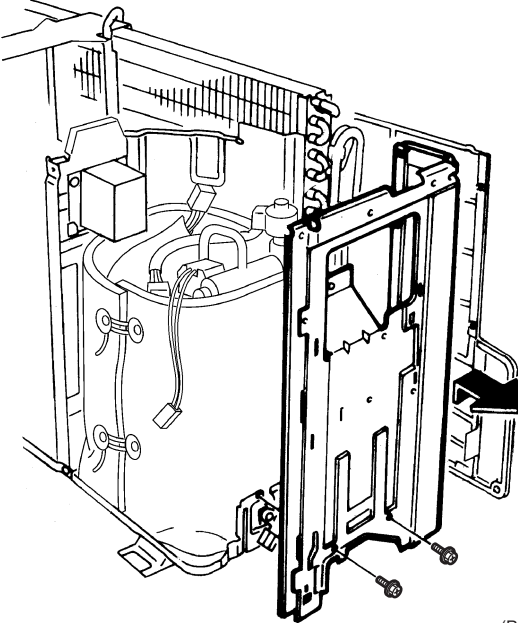
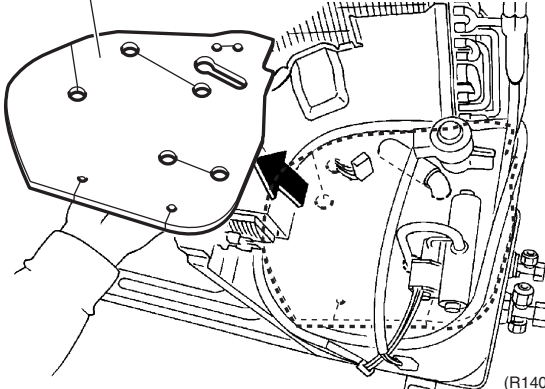

Warning Be sure to wait for 10 minutes or more after turning off all power supplies before disassembling work.

Step	Procedure	Points
<p>1. Remove the right side panel.</p> <p>1 Remove the 3 screws on the back side of the right side panel.</p> <p>2 Remove the 2 screws.</p> <p>3 Lift the right side panel to unfasten the 2 hooks and remove it.</p>	 <p>(R14018)</p>  <p>(R14019)</p>	<p>Preparation</p> <ul style="list-style-type: none"> Remove the electrical box according to "Removal of Electrical Box".
<p>2. Remove the sound blankets.</p> <p>1 Remove the sound blanket (top).</p>	<p>Sound blanket (top)</p>  <p>(R14055)</p>	<ul style="list-style-type: none"> Since the piping ports on the sound blanket are torn easily, remove the blanket carefully.

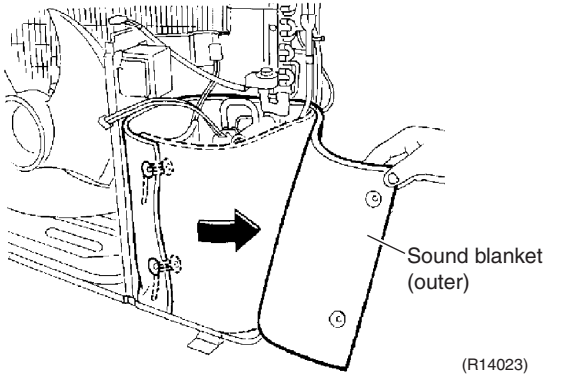
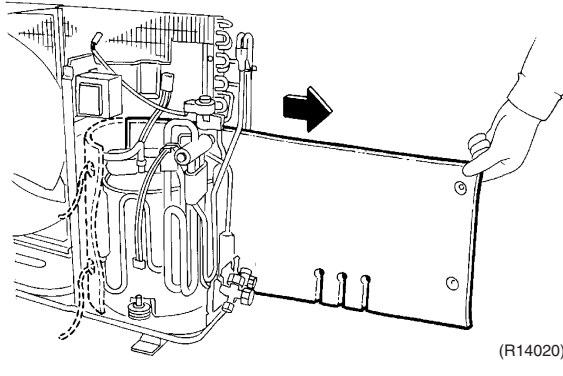
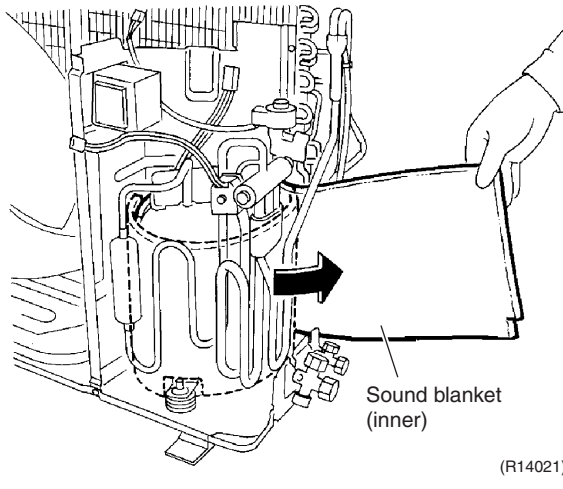
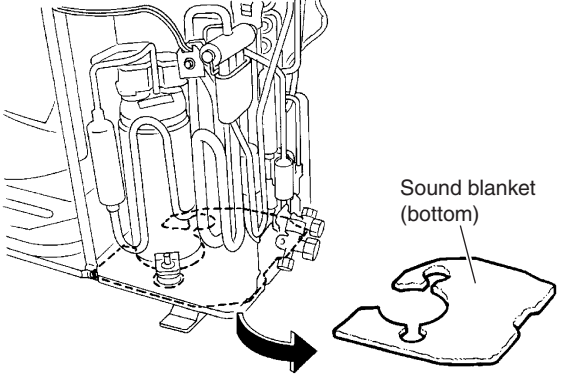
Step	Procedure	Procedure	Points
2	Untie the strings and open the sound blanket (outer).	 <p>(R14023)</p>	
3	Pull the sound blanket (outer) out.	 <p>(R14020)</p>	<ul style="list-style-type: none"> ■ Since the piping ports on the sound blanket are torn easily, remove the blanket carefully.
4	Open the sound blanket (inner) and pull it out.	 <p>(R14021)</p>	
5	Pull the sound blanket (bottom) out.	 <p>(R14022)</p>	

10. Removal of Thermistor Assembly

Procedure

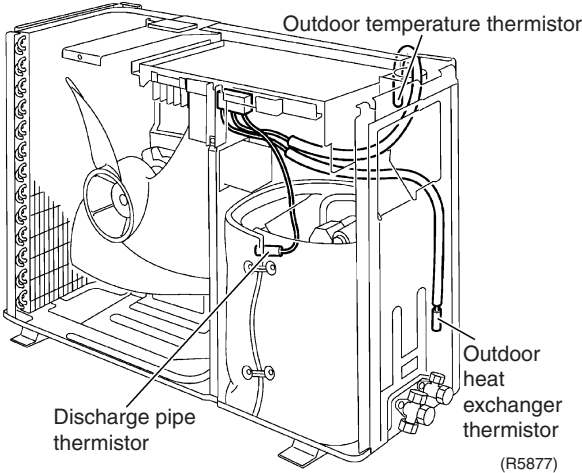
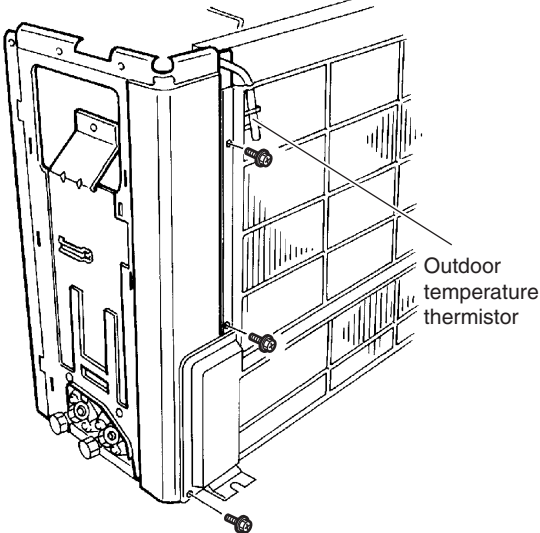
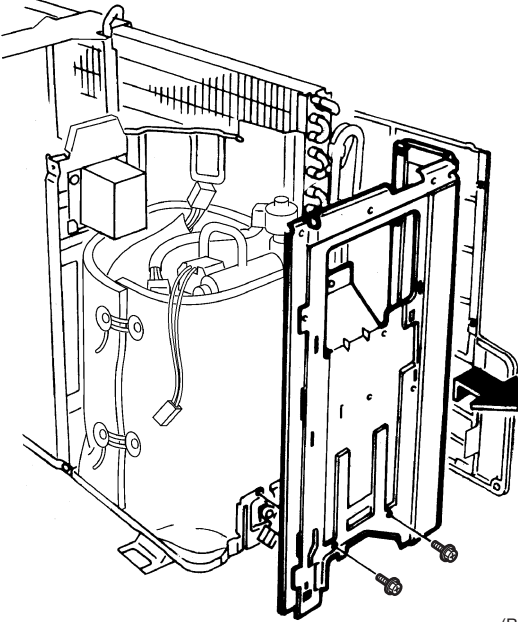

Warning Be sure to wait for 10 minutes or more after turning off all power supplies before disassembling work.

Step	Procedure	Points
1	<p>The figure shows the arrangement of the thermistor assembly.</p> 	<p>Preparation</p> <ul style="list-style-type: none"> Remove the electrical box according to "Removal of Electrical Box".
2	<p>Remove the 3 screws on the back side of the right side panel and detach the outdoor temperature thermistor.</p> 	
3	<p>Remove the 2 screws.</p>	
4	<p>Lift the right side panel to unfasten the 2 hooks and remove it.</p> 	

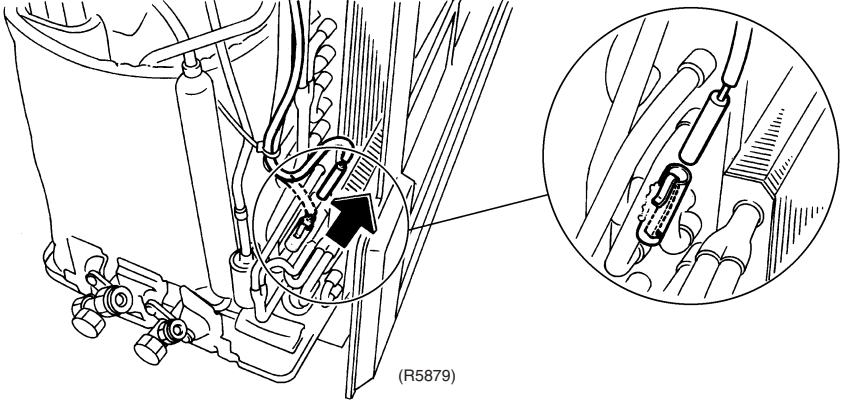
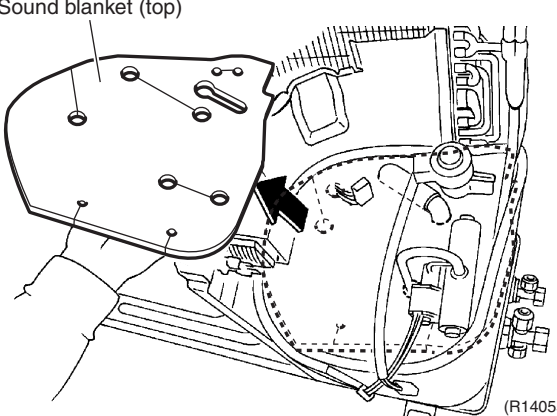
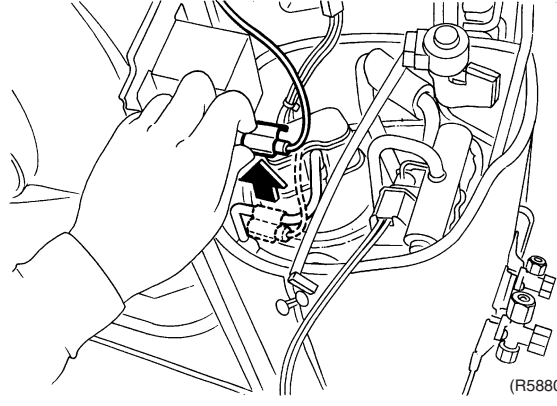
Step	Procedure	Points
5	<p>Pull out the outdoor heat exchanger thermistor.</p>  <p>(R5879)</p>	<ul style="list-style-type: none"> ■ Be careful not to lose the clip for the thermistor.
6	<p>Remove the sound blanket (top).</p>  <p>(R14055)</p>	<ul style="list-style-type: none"> ■ Since the piping ports on the sound blanket are torn easily, remove the blanket carefully.
7	<p>Release the discharge pipe thermistor.</p>  <p>(R5880)</p>	<ul style="list-style-type: none"> ■ Detach the discharge pipe thermistor while opening the thermistor fixing clip. ■ Be careful not to lose the clip for the discharge pipe thermistor. ■ Meet the edge of the thermistor and the clip when reassembling.

11. Removal of Reactor / Partition Plate

Procedure

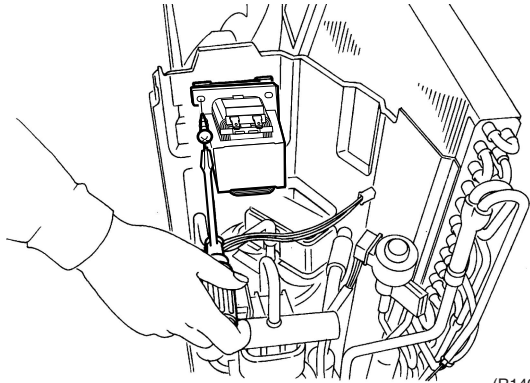
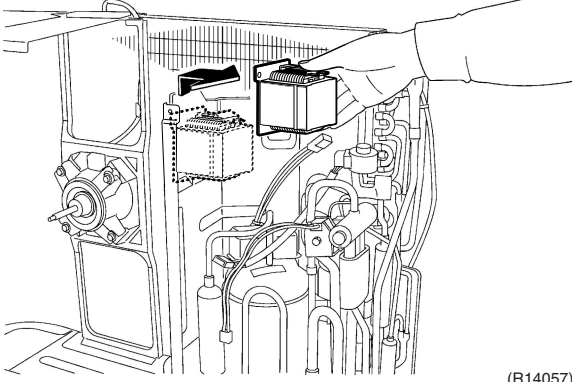
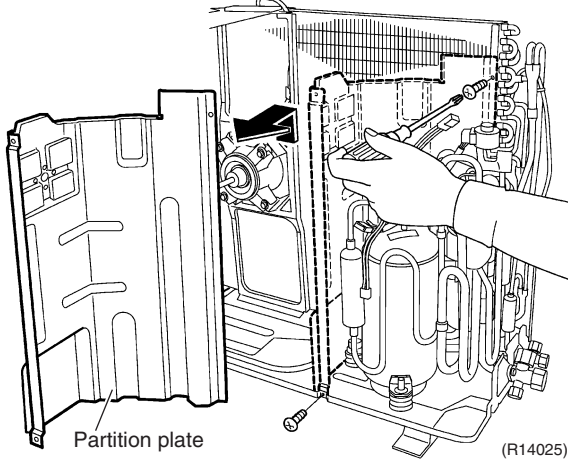
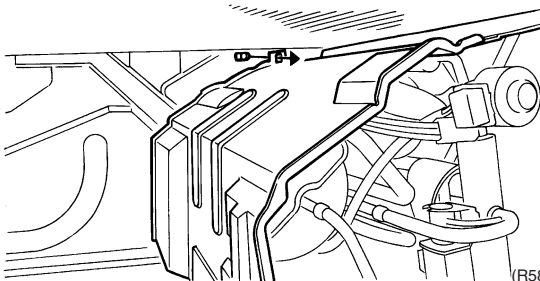

Warning Be sure to wait for 10 minutes or more after turning off all power supplies before disassembling work.

Step	Procedure	Points
1. Remove the reactor. 1 Remove the screw and remove the reactor.	 <p style="text-align: right;">(R14056)</p>  <p style="text-align: right;">(R14057)</p>	Preparation <ul style="list-style-type: none"> ■ Remove the sound blankets according to "Removal of Sound Blankets".
2. Remove the partition plate. 1 Remove the 2 screws. 2 Lift the partition plate and remove it.	 <p style="text-align: right;">(R14025)</p>  <p style="text-align: right;">(R5884)</p>	<ul style="list-style-type: none"> ■ When reassembling, make sure to catch the lower hook of the partition plate.

12. Removal of Four Way Valve

Procedure

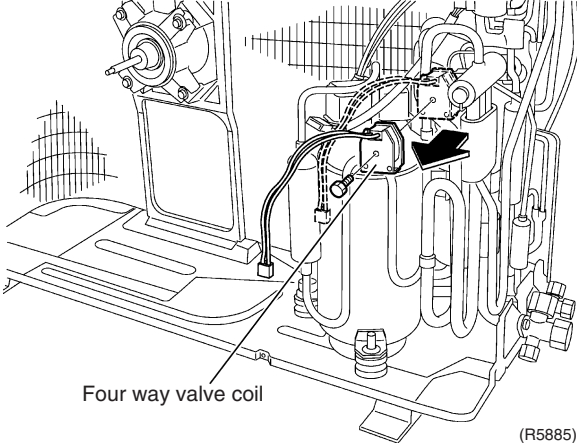
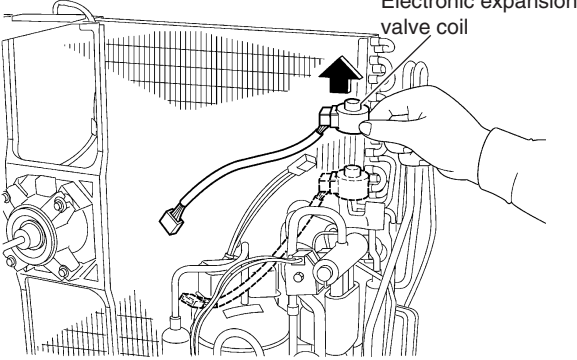
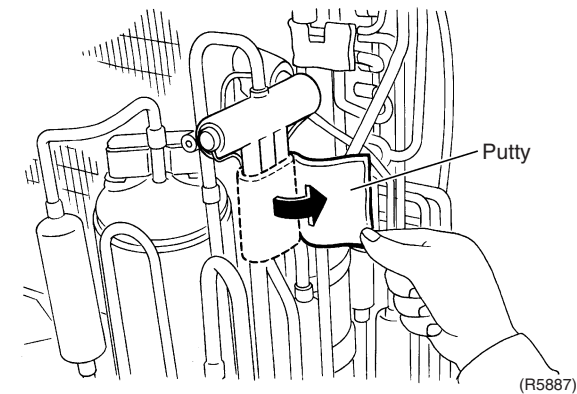

Warning Be sure to wait for 10 minutes or more after turning off all power supplies before disassembling work.

Step	Procedure	Points
1	<p>Remove the screw and remove the four way valve coil.</p>  <p style="text-align: center;">Four way valve coil</p> <p style="text-align: right;">(R5885)</p>	<p>Preparation</p> <ul style="list-style-type: none"> Remove the sound blankets according to "Removal of Sound Blankets".
2	<p>Pull out the electronic expansion valve coil.</p>  <p style="text-align: center;">Electronic expansion valve coil</p> <p style="text-align: right;">(R14026)</p>	
3	<p>Remove the putty.</p>  <p style="text-align: center;">Putty</p> <p style="text-align: right;">(R5887)</p>	

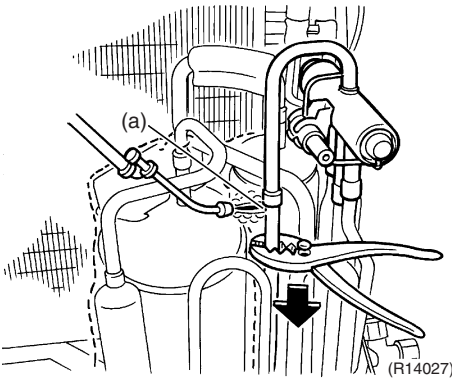
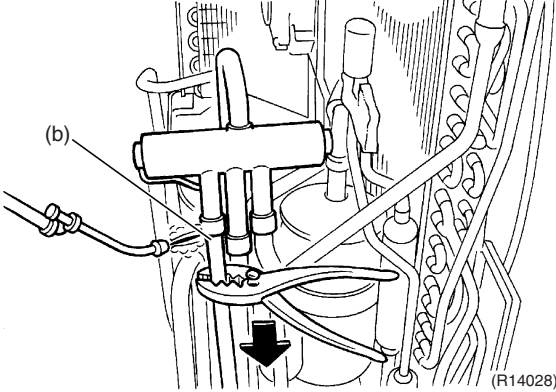
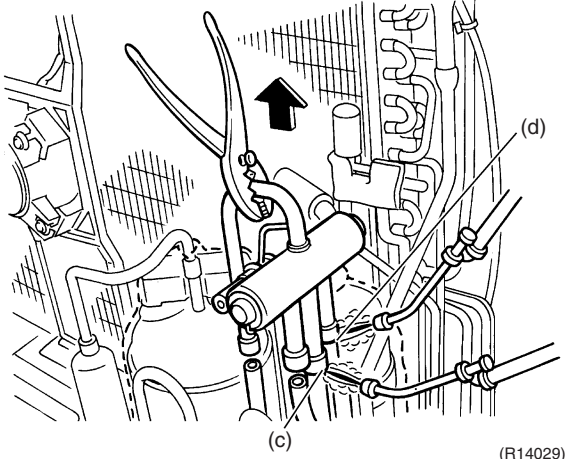
Step	Procedure	Points
<ul style="list-style-type: none"> ■ Before working, make sure that the refrigerant gas is empty in the circuit. ■ Be sure to apply nitrogen replacement when heating up the brazed part. 	 <p style="text-align: right;">(R14027)</p>	<p>Warning Be careful not to get yourself burnt with the pipes and other parts that are heated by the gas brazing machine.</p>
4	Heat up the 4 brazed parts of the four way valve. Disconnect them in the order of (a) (b) (c) (d).	<p>Warning If the refrigerant gas leaks during work, ventilate the room. (If the refrigerant gas is exposed to flames, toxic gas may be generated.)</p>
<p>Note:</p> <ul style="list-style-type: none"> ■ Do not use a metal saw for cutting pipes by all means because the sawdust comes into the circuit. ■ When withdrawing the pipes, be careful not to pinch them firmly with pliers. The pipes may get deformed. ■ Provide a protective sheet or a steel plate so that the brazing flame cannot influence peripheries. 	 <p style="text-align: right;">(R14028)</p>  <p style="text-align: right;">(R14029)</p>	<p>Caution From the viewpoint of global environment protection, do not discharge the refrigerant gas in the atmosphere. Make sure to collect all the refrigerant gas.</p> <p>Cautions for restoration</p> <ol style="list-style-type: none"> 1. Restore the piping by non-oxidation brazing. 2. It is required to prevent the carbonization of the oil inside the four way valve and the deterioration of the gaskets affected by heat. (Keep below 120°C.) For the sake of this, wrap the four way valve with wet cloth and provide water so that the cloth does not dry. <p>In case of difficulty with gas brazing machine</p> <ol style="list-style-type: none"> 1. Disconnect the brazed part where is easy to disconnect and restore. 2. Cut pipes on the main unit with a tube cutter in order to make it easy to disconnect.

13. Removal of Electronic Expansion Valve

Procedure

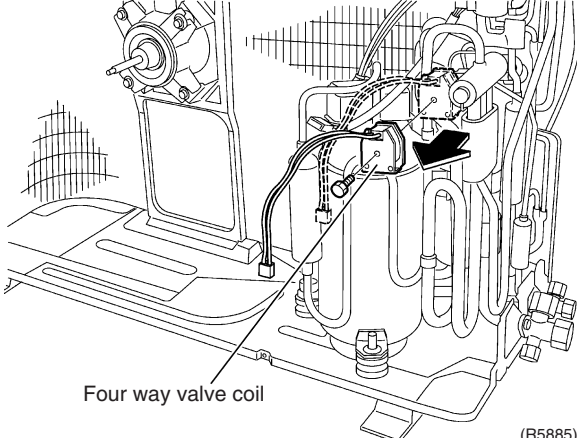
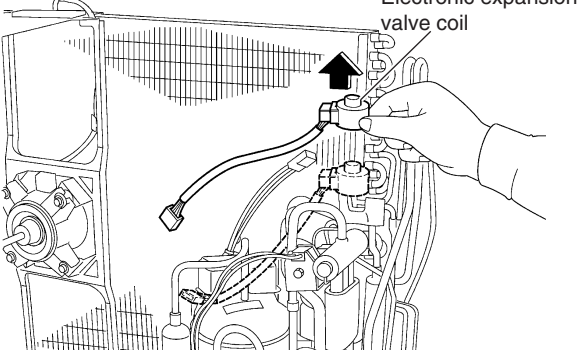
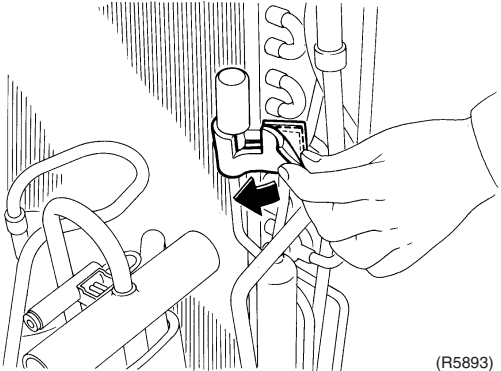
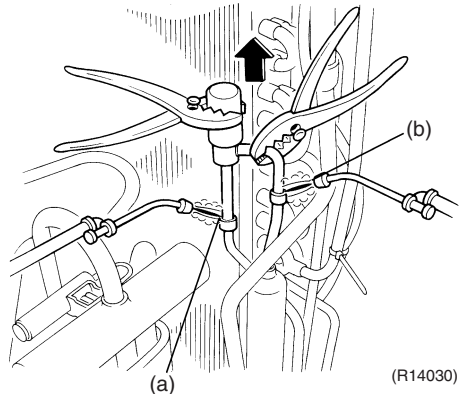

Warning Be sure to wait for 10 minutes or more after turning off all power supplies before disassembling work.

Step	Procedure	Points
1	Remove the screw and remove the four way valve coil.  <p style="text-align: center;">Four way valve coil (R5885)</p>	Preparation ■ Remove the sound blankets according to "Removal of Sound Blankets".
2	Pull out the electronic expansion valve coil.  <p style="text-align: center;">Electronic expansion valve coil (R14026)</p>	
3	Remove the putty.  <p style="text-align: center;">(R5893)</p>	<p>Warning Be careful not to get yourself burnt with the pipes and other parts that are heated by the gas brazing machine.</p>
■ Before working, make sure that the refrigerant gas is empty in the circuit. ■ Be sure to apply nitrogen replacement when heating up the brazed part.		<p>Warning If the refrigerant gas leaks during work, ventilate the room. (If the refrigerant gas is exposed to flames, toxic gas may be generated.)</p>
4	Heat up the 2 brazed parts and disconnect them in the order of (a) (b).  <p style="text-align: center;">(a) (b) (R14030)</p>	<p>Caution From the viewpoint of global environment protection, do not discharge the refrigerant gas in the atmosphere. Make sure to collect all the refrigerant gas.</p>

14. Removal of Compressor

Procedure

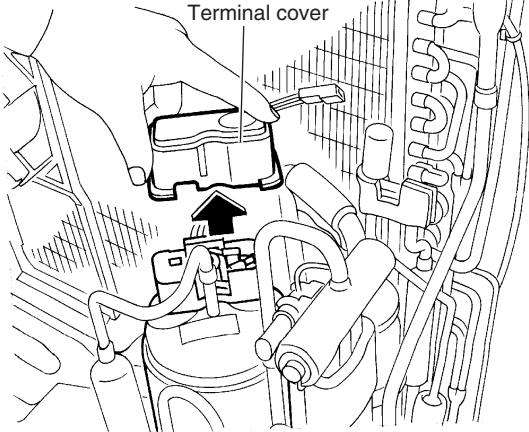
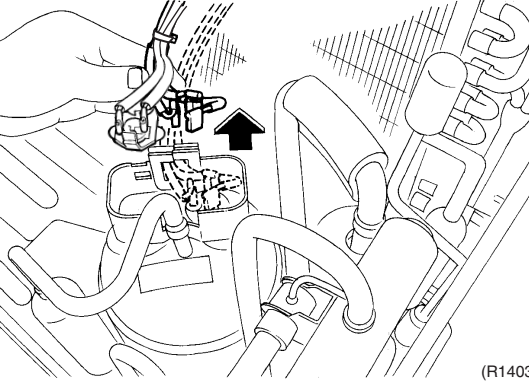
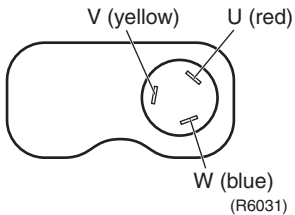
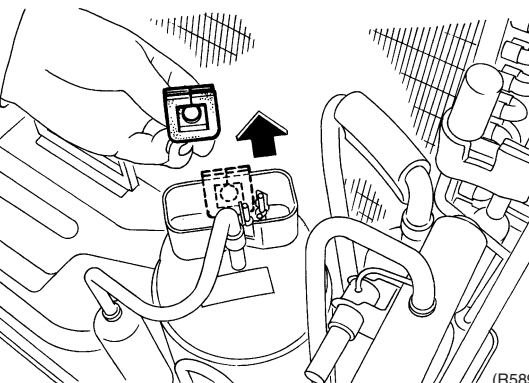
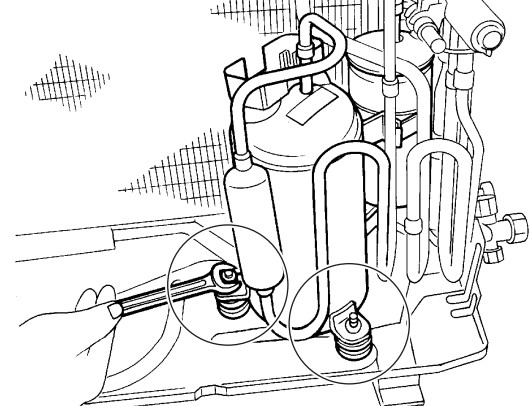

Warning Be sure to wait for 10 minutes or more after turning off all power supplies before disassembling work.

Step	Procedure	Points
1	Remove the terminal cover.  <p style="text-align: right;">(R14031)</p>	Preparation <ul style="list-style-type: none"> Remove the sound blankets according to "Removal of Sound Blankets".
2	Disconnect the compressor lead wires and detach the overload protector.  <p style="text-align: right;">(R14032)</p>	<ul style="list-style-type: none"> Be careful so as not to burn the compressor terminals or the name plate.  <p style="text-align: right;">(R6031)</p>
3	Remove the protecting bushing.  <p style="text-align: right;">(R5897)</p>	
4	Remove the 2 nuts.  <p style="text-align: right;">(R14033)</p>	

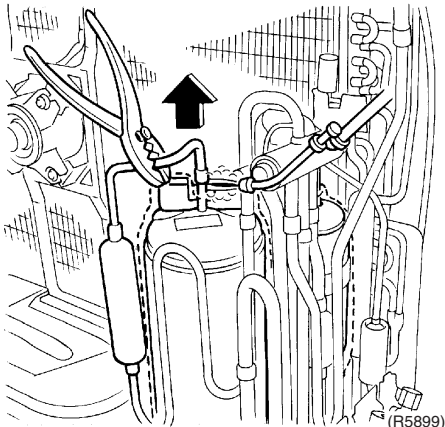
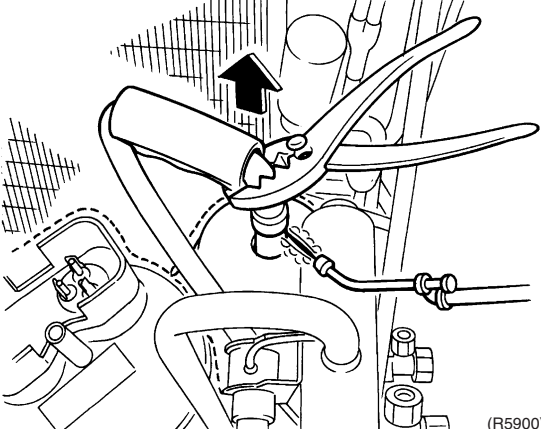
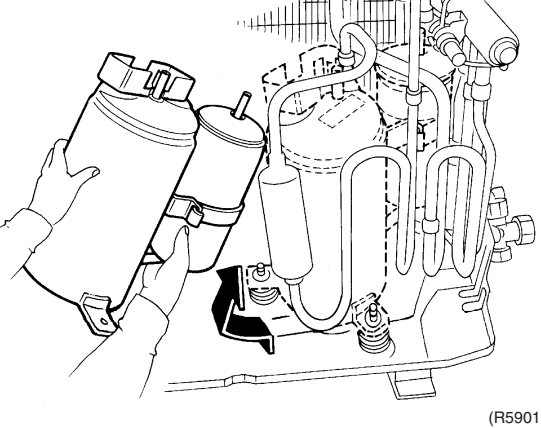
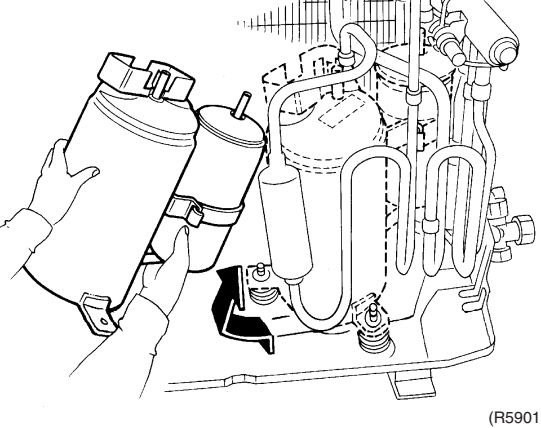
Step	Procedure	Points
<ul style="list-style-type: none"> ■ Before working, make sure that the refrigerant gas is empty in the circuit. ■ Be sure to apply nitrogen replacement when heating up the brazed part. 		<p>Warning Be careful not to get yourself burnt with the pipes and other parts that are heated by the gas brazing machine.</p>
<p>5 Heat up the brazed part of the discharge side and disconnect.</p>		<p>Warning If the refrigerant gas leaks during work, ventilate the room. (If the refrigerant gas is exposed to flames, toxic gas may be generated.)</p>
<p>6 Heat up the brazed part of the suction side and disconnect.</p>		<p>Warning Since it may happen that the refrigerant oil in the compressor catches fire, prepare wet cloth so as to extinguish fire immediately.</p> <p>Caution From the viewpoint of global environment protection, do not discharge the refrigerant gas in the atmosphere. Make sure to collect all the refrigerant gas.</p> <p>Cautions for restoration</p> <ol style="list-style-type: none"> 1. Restore the piping by non-oxidation brazing. 2. It is required to prevent the carbonization of the oil inside the four way valve and the deterioration of the gaskets affected by heat. (Keep below 120°C.) For the sake of this, wrap the four way valve with wet cloth and provide water so that the cloth does not dry.
<p>Note:</p> <ul style="list-style-type: none"> ■ Do not use a metal saw for cutting pipes by all means because the sawdust comes into the circuit. ■ When withdrawing the pipes, be careful not to pinch them firmly with pliers. The pipes may get deformed. ■ Provide a protective sheet or a steel plate so that the brazing flame cannot influence peripheries. ■ Be careful so as not to burn the compressor terminals, the name plate, the heat exchanger fin. 		<p>In case of difficulty with gas brazing machine</p> <ol style="list-style-type: none"> 1. Disconnect the brazed part where is easy to disconnect and restore. 2. Cut pipes on the main unit with a tube cutter in order to make it easy to disconnect.

Revision History

Month / Year	Version	Revised contents
07 / 2013	Si00-777	First edition

Warning



- Daikin products are manufactured for export to numerous countries throughout the world. Prior to purchase, please confirm with your local authorised importer, distributor and/or retailer whether this product conforms to the applicable standards, and is suitable for use, in the region where the product will be used. This statement does not purport to exclude, restrict or modify the application of any local legislation.
- Ask a qualified installer or contractor to install this product. Do not try to install the product yourself. Improper installation can result in water or refrigerant leakage, electrical shock, fire or explosion.
- Use only those parts and accessories supplied or specified by Daikin. Ask a qualified installer or contractor to install those parts and accessories. Use of unauthorised parts and accessories or improper installation of parts and accessories can result in water or refrigerant leakage, electrical shock, fire or explosion.
- Read the User's Manual carefully before using this product. The User's Manual provides important safety instructions and warnings. Be sure to follow these instructions and warnings.

If you have any enquiries, please contact your local importer, distributor and/or retailer.

Cautions on product corrosion

1. Air conditioners should not be installed in areas where corrosive gases, such as acid gas or alkaline gas, are produced.
2. If the outdoor unit is to be installed close to the sea shore, direct exposure to the sea breeze should be avoided. If you need to install the outdoor unit close to the sea shore, contact your local distributor.

Dealer

DAIKIN INDUSTRIES, LTD.

Head Office:
Umeda Center Bldg., 2-4-12, Nakazaki-Nishi,
Kita-ku, Osaka, 530-8323 Japan

Tokyo Office:
JR Shinagawa East Bldg., 2-18-1, Konan,
Minato-ku, Tokyo, 108-0075 Japan

http://www.daikin.com/global_ac/

©All rights reserved